



# SUPERIOR IDLER CATALOG







**SUPERIOR IDLER CATALOG**

# TABLE OF CONTENTS

- 6 Basic Roll Styles**
- 7 Basic Idler Styles**
- 8 Idler Offerings**
- 10 Ordering Guide: Superior Idlers**
- 11 Components Shipping Methods**
- 12 Ordering Guide: Roll Interchange**
- 14 Custom Idler Roll Selection**
- 16 CEMA B Idlers**
  - Troughing Idlers (Equal Length Rollers): 4" AND 5" Diameter
  - Rubber Cushion Impact Troughing Idlers: 4" and 5" Diameter
  - Return Idlers: 4" AND 5" Diameter
  - Flat Idlers: 4" AND 5" Diameter
  - Rubber Cushion Flat Idlers: 4" AND 5"
  - Rubber Cushion Return Idlers: 4" AND 5"
  - Urathon® Return Roll: 5" Diameter
  - Self-Aligning Troughing Idlers: 4" AND 5"
  - Self-Aligning Return Idlers: 4" AND 5" Diameter
  - Offset Center Roll Idlers: 4" AND 5" Diameter
  - Channel Mount: 4" AND 5" Diameter
  - Channel Mount Impact Idlers: 4" AND 5" Diameter
- 26 CEMA C Idlers**
  - Troughing Idlers (Equal Length Rollers): 4" Diameter
  - Troughing Idlers (Equal Length Rollers): 5" Diameter
  - Troughing Idlers (Equal Length Rollers): 6" Diameter
  - Rubber Cushion Impact Troughing Idlers: 4" Diameter
  - Rubber Cushion Impact Troughing Idlers: 5" Diameter
  - Rubber Cushion Impact Troughing Idlers: 6" Diameter
  - Return Idlers: 4", 5" and 6" Diameter
  - Flat Idlers: 4", 5", AND 6" Diameter
  - Rubber Cushion Return Idlers: 4", 5", AND 6" Diameter
  - Rubber Cushion Flat Idlers: 4", 5", AND 6" Diameter
  - Urathon® Return Rolls: 5" AND 6" Diameter
  - Self-Aligning Troughing Idlers: 4" Diameter
  - Self-Aligning Troughing Idlers: 5" Diameter
  - Self-Aligning Troughing Idlers: 6" Diameter
  - V-Return Idlers: 4", 5", AND 6" Diameter
  - Self-Aligning Return Idler: 4", 5" AND 6" Diameter
  - Garland Idlers: 4", 5", AND 6" Diameter
  - Feeder / Picking Troughing Idlers: 4", 5", AND 6" Diameter
  - Troughing Idlers (Unequal Length Rolls): 4" Diameter
  - Troughing Idlers (Unequal Length Rolls): 5" Diameter
  - Troughing Idlers (Unequal Length Rolls): 6" Diameter
  - Offset Center Roll Idler: 4" Diameter
  - Offset Center Roll Idler: 5" Diameter
  - Offset Center Roll Idler: 6" Diameter
  - Low Profile Standard Mount: 4" AND 5" Diameter
  - Channel Mount: 4" AND 5" Diameter
  - Channel Mount Impact Idlers: 4" AND 5" Diameter
- 51 CEMA D Idlers**
  - Troughing Idlers (Equal Length Rollers): 5" AND 6" Diameter
  - Rubber Cushion Impact Troughing Idler: 5" and 6" Diameter
  - Return Idlers: 5" AND 6" Diameter
  - Flat Idlers: 5" AND 6" Diameter
  - Rubber Cushion Return Idlers: 5" AND 6" Diameter
  - Rubber Cushion Flat Idlers: 5" AND 6" Diameter
  - Urathon® Return Rolls: 5" AND 6" Diameter
  - Self-Aligning Troughing Idlers: 5" AND 6" Diameter
  - V-Return Idler: 5" AND 6" Diameter
  - Self-Aligning Return Idlers: 5" AND 6" Diameter
  - Feeder / Picking Troughing Idlers: 5" AND 6" Diameter
  - Troughing Idlers (Unequal Length Rollers): 5" AND 6" Diameter
- 61 DX Idlers**
  - Troughing Idlers (Equal Length Rollers): 5" AND 6" Diameter
  - Rubber Cushion Impact Troughing Idler: 5" AND 6" Diameter
  - Return Idlers: 5" AND 6" Diameter
  - Flat Idlers: 5" AND 6" Diameter
  - Rubber Cushion Return Idlers: 5" AND 6" Diameter
  - Rubber Cushion Flat Idlers: 5" AND 6" Diameter
  - V-Return Idler: 5" AND 6" Diameter
- 66 CEMA E Idlers**
  - Troughing Idler (Equal Length Rollers): 6" AND 7" Diameter
  - Rubber Cushion Impact Troughing Idlers: 6" AND 7" Diameter
  - Self-Aligning Troughing Idlers: 6" AND 7" Diameter
  - Return Idlers: 6" AND 7" Diameter
  - Flat Idlers: 6" AND 7" Diameter
  - Rubber Cushion Return Idlers: 6" AND 7" Diameter
  - Rubber Cushion Flat Idlers: 6" AND 7" Diameter
  - Urathon® Return Rolls: 6" AND 7" Diameter
  - V-Return Idlers: 6" AND 7" Diameter
  - Return Self-Aligner Idlers: 6" AND 7" Diameter
- 74 40DT Idlers**
  - Troughing Idler (Equal Length Rollers): 6" AND 7" Diameter
  - Rubber Cushion Impact Troughing Idlers: 6" AND 7" Diameter
  - Return Idlers: 6" AND 7" Diameter
  - Flat Idlers: 6" AND 7" Diameter
  - Rubber Cushion Return Idlers: 6" AND 7" Diameter
  - Rubber Cushion Flat Idlers: 6" AND 7" Diameter
  - V-Return Idlers: 6" AND 7" Diameter

---

**79 45DT Idlers**

Troughing Idler (Equal Length Rollers): 6" Diameter  
Troughing Idler (Equal Length Rollers): 7" Diameter  
Troughing Idler (Equal Length Rollers): 7.5" Diameter  
Rubber Cushion Impact Troughing Idlers: 6" Diameter  
Rubber Cushion Impact Troughing Idlers: 7" Diameter  
Rubber Cushion Impact Troughing Idlers: 7.5" Diameter  
Return Idlers: 6", 7" AND 7.5" Diameter  
Flat Idlers: 6", 7" AND 7.5" Diameter  
Rubber Cushion Return Idlers: 6" AND 7" Diameter  
Rubber Cushion Flat Idlers: 6" AND 7" Diameter  
V-Return Idlers: 6", 7" AND 7.5" Diameter

**88 CEMA F idlers**

Troughing Idlers (Equal Length Rollers): 6" Diameter  
Troughing Idlers (Equal Length Rollers): 7" Diameter  
Troughing Idlers (Equal Length Rollers): 8" Diameter  
Rubber Cushion Impact Troughing Idlers: 7" AND 8" Diameter  
Return Idlers: 6", 7" and 8" Diameter  
Flat Idlers: 6", 7" AND 8" Diameter  
Rubber Cushion Return Idlers  
Rubber Cushion Flat Idlers: 7" AND 8" Diameter  
V-Return Idlers: 6", 7" AND 8" Diameter

**95 50DT idlers**

Troughing Idlers (Equal Length Rollers): 6" Diameter  
Troughing Idlers (Equal Length Rollers): 7" Diameter  
Troughing Idlers (Equal Length Rollers): 8" Diameter  
Rubber Cushion Impact Troughing Idlers: 7" AND 8" Diameter  
Return Idlers: 6", 7" AND 8" Diameter  
Flat Idlers: 6", 7" AND 8" Diameter  
Rubber Cushion Return Idlers: 7" AND 8" Diameter  
Rubber Cushion Flat Idlers: 7" AND 8" Diameter  
V-Return Idlers: 6", 7" AND 8" Diameter

**102 60DT idlers**

Troughing Idlers (Equal Length Rollers): 7" AND 8" Diameter  
Rubber Cushion Impact Troughing Idler: 8" Diameter  
Return Idlers: 7" AND 8" Diameter  
Flat Idlers: 7" AND 8" Diameter  
Rubber Cushion Return Idlers: 8" Diameter  
Rubber Cushion Flat Idlers: 8" Diameter  
V-Return Idlers: 7 & 8 inch Diameter

**107 Component Parts and Replacement Rolls**

CEMA B Replacement Rolls  
CEMA C Replacement Rolls  
Other Parts  
CEMA D Replacement Rolls  
CEMA E Replacement Rolls

**109 40 Series Idlers**

Return Roll U-Bolts

**110 Live Shaft Idlers****111 Specialized Idler Designs****112 Components Accessories**

Navigator Return Trainer: 7-3/4" and 7", 10" and 10-3/4" Diameter  
Return Guides  
Pipe Conveyor Roller Bracket Assembly  
Return Guide & Drop Bracket  
Stub Roll Idlers: 4", 5" and 6" Diameter  
Urethane Vertical Side Guide Roll: 3-1/4" Diameter  
Side Guide Idlers: 4" x 5-3/8" Rollers  
Vertical Side Guide Roll: 2" and 4" Diameter

**116 Return & Flat Brackets Styles**

CEMA B, C, and D Brackets  
CEMA E Brackets  
CEMA F Return Brackets  
81 & 91 Series Return Brackets -Hex  
CB Brackets

**119 Base Plates**

CEMA B, C and D Idlers  
CEMA E, F, and Double Tube Idlers

**120 Idler Selection Procedure****125 Terms and Conditions**

# BASIC ROLL STYLES



**CEMA RATED ROLLS**



**MOXIE® ROLLS**

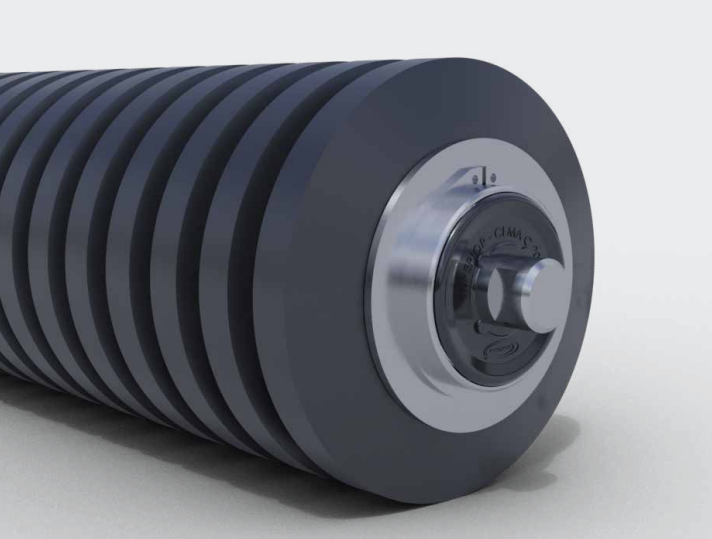

**IMPACT ROLLS**

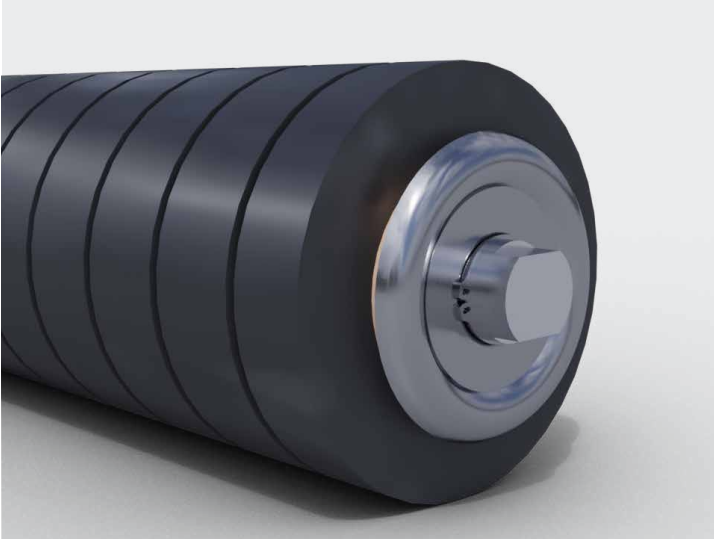

**VULCANIZED ROLL**



**DX ROLLS**

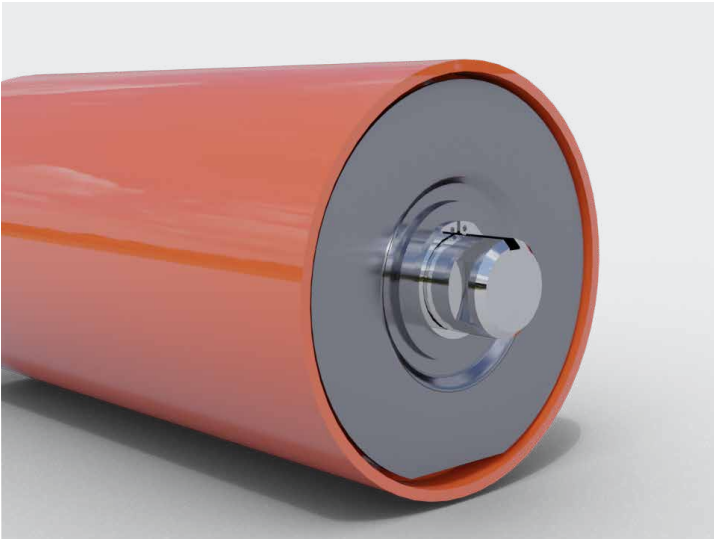

**DOUBLE TUBE (DT) ROLLS**

# BASIC IDLER STYLES



EQUAL TROUGHING IDLERS



IMPACT IDLERS



OFFSET CENTER ROLL IDLERS



CHANNEL MOUNT LOW PROFILE IDLERS



FEEDER/PICKING IDLERS



UNEQUAL TROUGHING IDLERS



CB504 SERIES IDLERS



GARLAND IDLERS



RETURN BELT IDLERS



RUBBER CUSHION RETURN IDLERS



URATHON® RETURN ROLL



SPIRAL URATHON® RETURN ROLL



SELF-ALIGNER IDLERS



SELF-ALIGNER RETURNS



FLAT CARRIER IDLERS



RUBBER CUSHION FLAT CARRIES



LIVE SHAFT ROLLERS



40 SERIES IDLERS



VARIABLE PITCH IDLERS



V-RETURN IDLERS



WIRE ROPE IDLERS



BEATER BAR



URATHON® BEATER ROLL

# IDLER OFFERINGS

## STEEL ROLL OFFERING BY CLASS

CLASS	BEARING	DIAMETER inch (mm)	SHELL THICKNESS inch (mm)	BELT WIDTH inch (mm)	TUBE
CEMA B	17mm	4", 5" (101, 127)	1/8", 5/32" (3.1, 3.9)	18" - 48" (457 - 1,219)	Single
CEMA C	20mm	4", 5", 6" (101, 127, 152)	1/8", 5/32", 3/16" (3.1, 3.9, 4.7)	18" - 60" (457 - 1,524)	Single
CEMA D	25mm	5", 6" (127, 152)	5/32", 3/16" (3.9, 4.7)	24" - 72" (609 - 1,828)	Single
DX	30mm	5", 6" (127, 152)	1/4" (6.3)	30" - 72" (762 - 1,828)	Single
CEMA E	40mm	6", 7" (152, 177)	1/4" (6.3)	36" - 96" (914 - 2,438)	Single
40DT	40mm	6", 7" (152, 177)	1/4" x 2 (6.3 x 2)	36" - 72" (914 - 1,828)	Double
45DT	45mm	6", 7", 7.5" (152, 177, 190)	1/4" x 2 (6.3 x 2)	54" - 108" (1,371 - 2,743)	Double
CEMA F	50mm	7", 8" (177, 203)	1/2", 3/4" (12.7, 19.0)	42" - 120" (1,066 - 3,048)	Single
50DT	50mm	7", 8" (177, 203)	1/4" x 2 (6.3 x 2)	42" - 120" (1,066 - 3,048)	Double
60DT	60mm	7", 8" (177, 203)	1/4" x 2 (6.3 x 2)	60" - 120" (1,524 - 3,048)	Double

## IMPACT ROLL OFFERING BY CLASS

CLASS	BEARING	DIAMETER inch (mm)	BELT WIDTH inch (mm)	IDLER TYPES	
				EI	RETI
CEMA B	17mm	4", 5" (101, 127)	18" - 48" (457 - 1,219)	tires	tires
CEMA C	20mm	4", 5", 6" (101, 127, 152)	18" - 60" (457 - 1,524)	tires	tires
CEMA D	25mm	5", 6" (127, 152)	24" - 72" (609 - 1,828)	tires	tires
DX	30mm	5", 6" (127, 152)	30" - 72" (762 - 1,828)	vulcanized	vulcanized
CEMA E	40mm	6", 7" (152, 177)	36" - 96" (914 - 2,438)	tires	tires
CEMA F	50mm	7", 8" (177, 203)	42" - 120" (1,066 - 3,048)	vulcanized	vulcanized
CEMA G	60mm	7", 8" (177, 203)	60" - 120" (1,524 - 3,048)	vulcanized	vulcanized
40DT	40mm	6", 7" (152, 177)	36" - 72" (914 - 1,828)	vulcanized	vulcanized
45DT	45mm	6", 7", 7.5" (152, 177, 190)	54" - 108" (1,371 - 2,743)	vulcanized	vulcanized
50DT	50mm	6", 7", 8" (152, 177, 203)	42" - 120" (1,066 - 3,048)	vulcanized	vulcanized
60DT	60mm	7", 8" (177, 203)	60" - 120" (1,524 - 3,048)	vulcanized	vulcanized

## IDLER STAND FEATURES

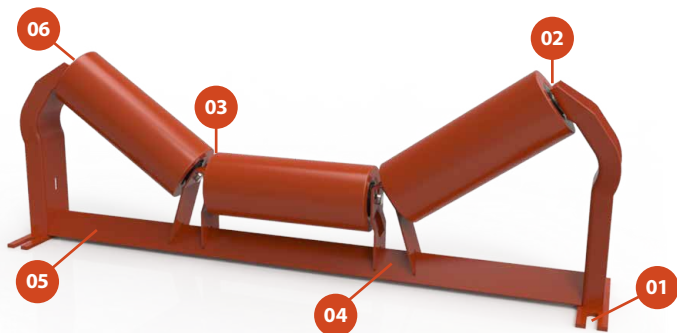





- 01/ Open end base allows access for single or double bolt holes.
- 02/ No fugitive material pinch points between roll and frame.
- 03/ Narrow roll gap eliminates pinch point, which damages belt.
- 04/ Non-clogging center stands.
- 05/ Base angle sheds material and prevents build-up.
- 06/ Corner or inset weld available.



# APPLICATION-SPECIFIC IDLER SEALS



## COLORS AND APPLICATIONS

SEAL COLOR	SEAL NAME	APPLICATION EXAMPLES	BENEFITS
	Standard	Traditional material handling not described above. Typically 80-90% of applications.	While testing our application specific models, we redesigned our standard for the best bearing protection yet.
	Wet	Wash or dredge processes. Frequent washdowns.	Special double contact seal defends bearing from moisture penetration.
	Dry	Crushing and screening producing dust with minimal fines.	Oiled and contact seal protects bearing from dry particles and grit.
	Eco	Overland or long distance material handling sites.	Seal reduces drag and roll resistance for less horsepower at startup/operation.
	Titanium™	Washed sand, fines removal or dredging. Most extreme conditions.	Combination of design characteristics from wet and dry seals for ultimate bearing protection.

# ORDERING GUIDE: SUPERIOR IDLERS

Superior makes ordering easy with a simple number and letter system so you can easily jot down the idlers you need and relay them to our sales staff. Superior manufactures many different styles of CEMA B, C, D, E, and F idlers along with a full line of CB-504 style bearing idlers and rollers. Simply follow the procedure below and you'll be on your way to placing an accurate order.

**C5 - 35 E - 36 - MOX - TTM**

**CEMA RATING**  
(or Series) - Specify either CEMA B, C, D, E, or F.

**ROLL DIAMETER**  
Specify either 4, 5, 6, 7, or 8 for the corresponding roll size diameter.

**TROUGHING ANGLE**  
Troughing Angle - Specify either 20, 35, or 45 for the corresponding troughing angle. V-Return - Specify either 10, 15 for the corresponding troughing angle. For standard return and live shaft products disregard the angle.

**IDLER TYPE LETTER**  
Specify the idler identification letter for the particular idler you may need from the list on the right. →

**BELT WIDTH**  
Specify either 18, 24, 30, 36, 42, 48, 54, 60, 72, 84, 96, 108, or 120 depending on or CEMA rating.

**ROLL STYLE**  
Specify either "MOX" for Moxie® Rolls, "DT" for Double-Tube Idler or "DX" for DX Idler.

**SEAL STYLE**  
Specify either "WET" for Wet Seal, "DRY" for Dry Seal, "ECO" for Eco Seal, or "TTM" for Titanium™ Seal.

## IDLER TYPE LIST

- E.....Troughing Idler Equal Length Rolls
- EA.....Self-Aligning Troughing Idler
- BA.....Bi-Directional Aligning Troughing Idler
- EI.....Rubber Cushion Troughing Idler
- GO.....Offset Troughing Idler
- GOI.....Rubber Cushion Offset Troughing Idler
- U.....Troughing Idler Unequal Length Rolls
- UI.....Rubber Cushion Troughing Idler Unequal Length Rolls
- P.....Feeder / Picking Idler
- PI.....Rubber Cushion Feeder/Picking Idler
- RET.....Return Idler
- FLT.....Flat Carrier Idler
- RETA.....Return Self-Aligning Idler
- RETI.....Return Rubber Cushion Idler
- FLTI.....Flat Carrier Rubber Cushion Idler
- CM.....Low-Profile Channel Mount Idler
- CMI.....Channel Mount Impact Low Profile Idler
- SM.....Low-Profile Standard Mount Idler
- SMI.....Standard Mount Impact Low Profile Idler
- RETAI.....Return Self-Aligning Rubber Lagged Cushion Idler
- EW.....Wire Rope Idler
- EWI.....Rubber Cushion Wire Rope Idler
- VPE.....Variable Pitch Idler
- VPEI.....Rubber Cushion Variable Pitch Idler
- RETU.....Urathon® Return
- RETUSP.....Spiral Urathon® Return
- RETV.....V-Return Idler
- RETVI.....Rubber Cushion V-Return Idler
- IVR.....Inverted V-Return Idler
- CMP.....Low-Profile Channel Mount Feeder/Picking Idler
- CMPI.....Rub. Cush. Low-Profile Chnnl Mount Feeder/Picking Idler
- IM.....Low-Profile Inboard Mount Idler
- IMI.....Rubber Cushion Low-Profile Inboard Mount Idler
- SO.....Underground Box Frame Idler
- SB.....Underground Single Beam Idler
- MOX.....Moxie® Roll (i.e. C5-35E-30MOX)
- LS.....Live Shaft Roller (i.e. LS-536)
- LSI.....Rubber Cushion Live Shaft Roller (i.e. LSI-548)
- LSB.....Live Shaft Beater (i.e. LSB-530-107)

# COMPONENTS SHIPPING METHODS

CARRIER APPROVED METHODS THAT REDUCE DAMAGE DURING TRANSPORT

## IDLER METHODS

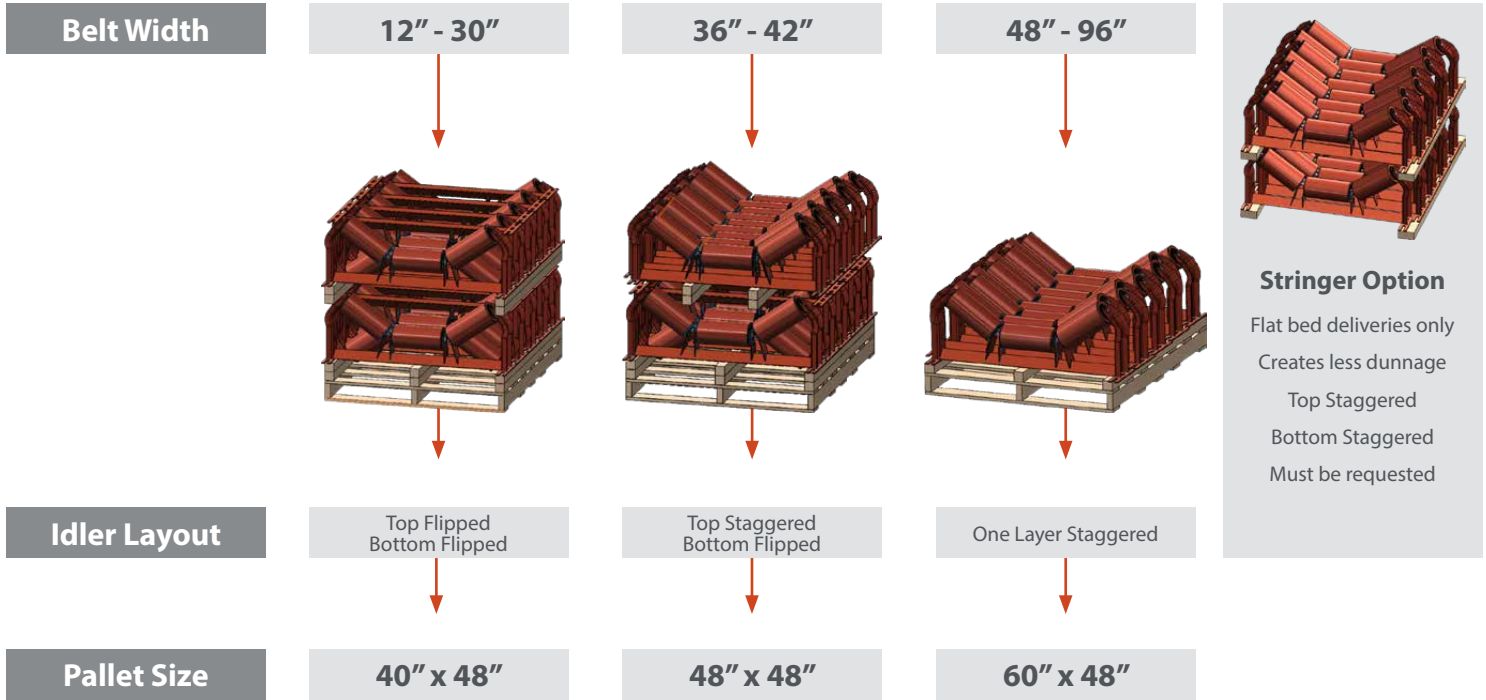

## PULLEY METHOD

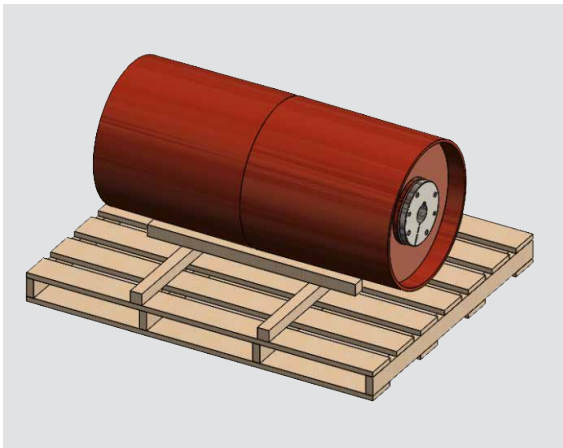

- » One standard packaging style speeds shipping process
- » One piece pallet versus splicing two pallets together
- » All parts of pulley confined to pallet (no exposed shafting)
- » Shafts protected with nylon sleeve
- » Core Systems® Design projects use custom-designed packaging

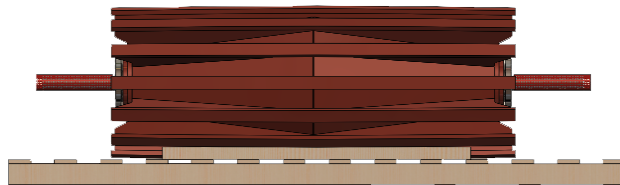

## CUSTOM PACKAGING

We certainly understand that every customer's packaging needs are unique. As always, we are here to provide the best solution to packaging your purchased products. Please ask us about custom packaging!

# ORDERING GUIDE: ROLL INTERCHANGE

Superior makes ordering easy with a simple number and letter system so you can easily jot down the idlers you need and relay them to our sales staff. Superior manufactures many different styles of CEMA B, C, D, E, and F idlers along with a full line of CB-504 style bearing idlers and rollers. Simply follow the procedure below and you'll be on your way to placing an accurate order.

**C6-360100-TTM**

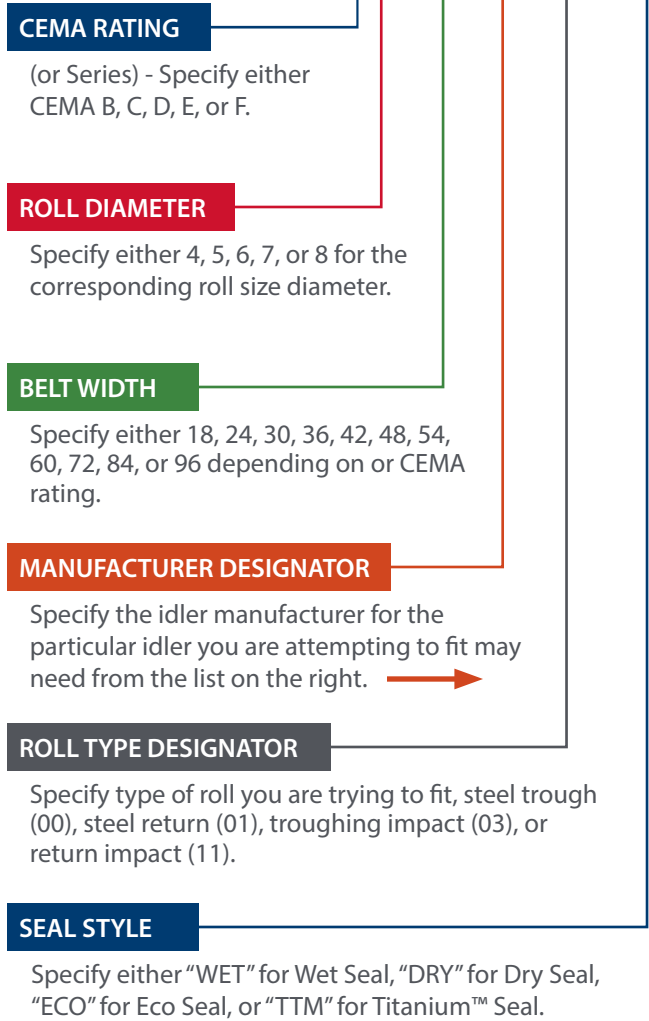

## MANUFACTURER

- 01..... Precision
- 02..... Continental (HC-slot)
- 03..... Stephens Adamson
- 04..... DBT
- 05..... FMC (slot)
- 06..... Hewitt-Robins (slot)
- 07..... Luff / Clemro®
- 08..... Assink
- 09..... Strongco
- 10..... Douglas (slot)
- 11..... FMC 3000 (nut)
- 12..... Douglas (nut)
- 13..... Rexnord (nut)
- 14..... Hewitt-Robins (nut)
- 15..... Continental (H+-nut)
- 16..... Goodman (nut)
- 17..... Prok
- 21..... Trio / Wehr

# ORDERING GUIDE: ROLL INTERCHANGE

## RETRO FIT ROLL DIMENSIONS

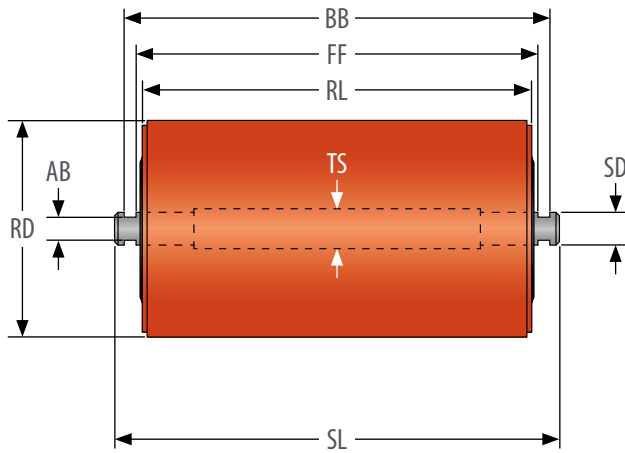

## ROLLER

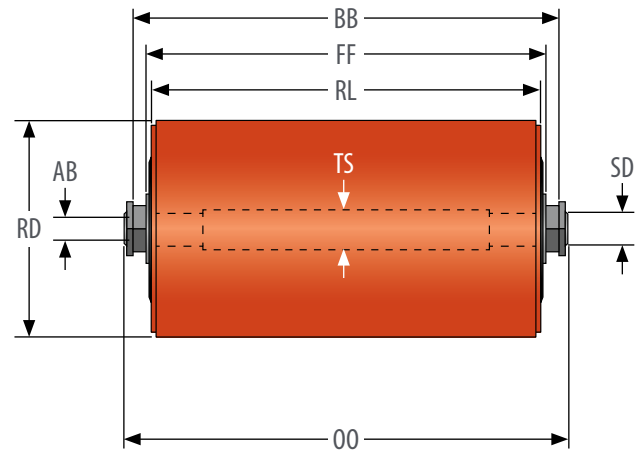

	EXAMPLE	ROLL 1
Shaft Type (slot/nut)	Slot	
Roll Diameter (RD)	5	
Roll Length (RL)	11.0625	
Frame Fit (FF)	11.30	
Slot-to-Slot (BB)	11.85	
Across Slot (AB)	.545	
Shaft Diameter (SD)	20mm	
Shaft Length (SL)	12.3125	
Through Shaft Diameter (TS)	20mm	
Hex Nut Outside-to-Outside (OO)	-	

## HEX NUT END

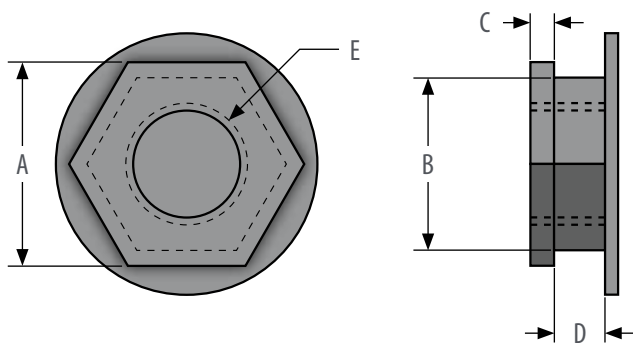

## SLOTTED SHAFT END

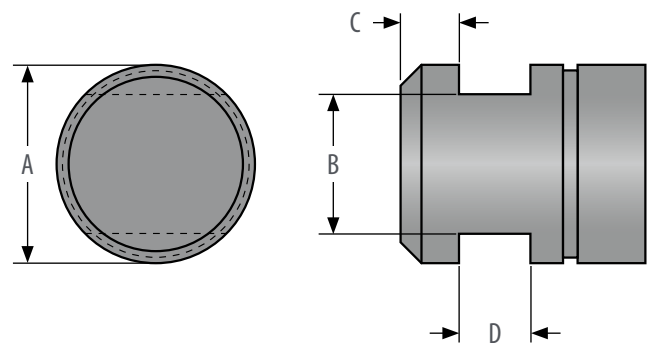

SLOT/HEX NUT DIMS	EXAMPLE	ROLL 1
A	20mm	
B	.545	
C	.231	
D	.275	
E	-	

# CUSTOM IDLER ROLL SELECTION

Please fill-in the following information and fax it to 320-585-5644.

NAME

EMAIL ADDRESS

PHONE NUMBER

COMPANY NAME

CITY

STATE

ZIP

## SLOTTED SHAFT STYLE



FRAME FIT

SHAFT DIAMETER

ROLL LENGTH

SHAFT LENGTH

ROLL DIAMETER

### SLOT STYLE



NOTCH THICKNESS

FLANGE THICKNESS

NOTCH WIDTH

### FLAT STYLE



FLAT DEPTH

FLAT THICKNESS

## HEX NUT STYLE



FRAME FIT

SHAFT DIAMETER

ROLL LENGTH

SHAFT LENGTH

ROLL DIAMETER

### HEX STYLE



ACROSS FLATS

BROACH/NUT WIDTH

FLANGE WIDTH

MINOR WIDTH/DIAMETER

### ROUND STYLE



ACROSS FLATS

BROACH/NUT WIDTH

FLANGE WIDTH

MINOR WIDTH/DIAMETER

# CUSTOM IDLER ROLL SELECTION

This is a reference page to be used to assist you to fill-in the previous page.

## SLOTTED SHAFT STYLE

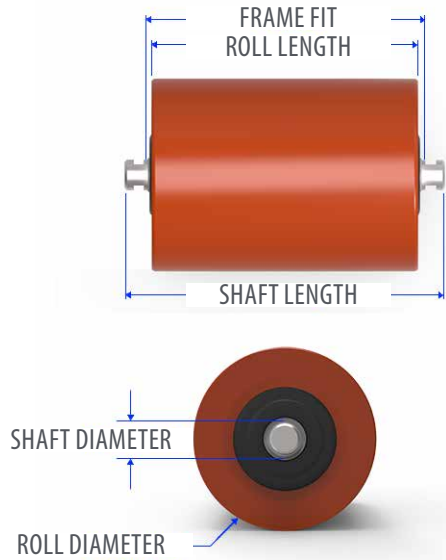

## HEX NUT STYLE

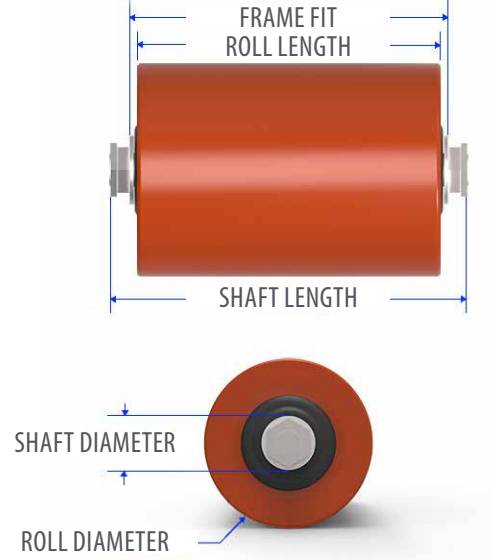

## SLOT STYLE



## HEX STYLE

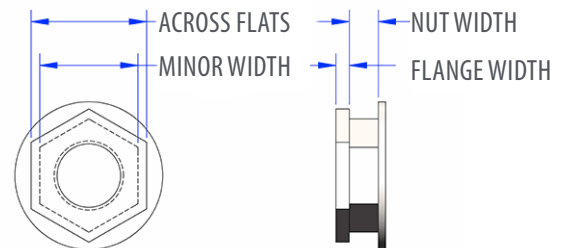

## FLAT STYLE

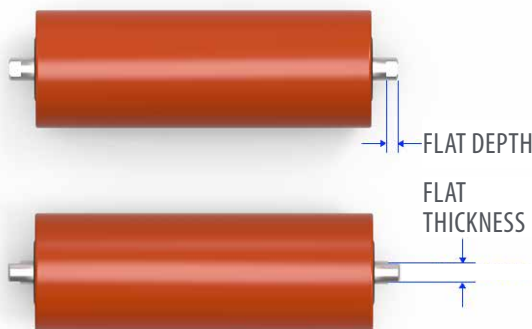

## ROUND STYLE

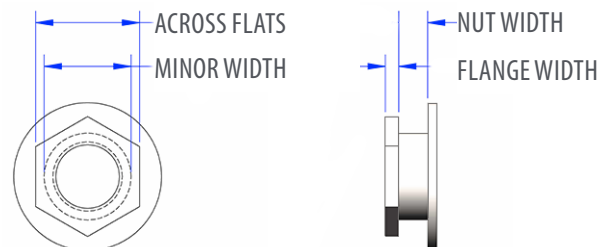

# CEMA B IDLERS

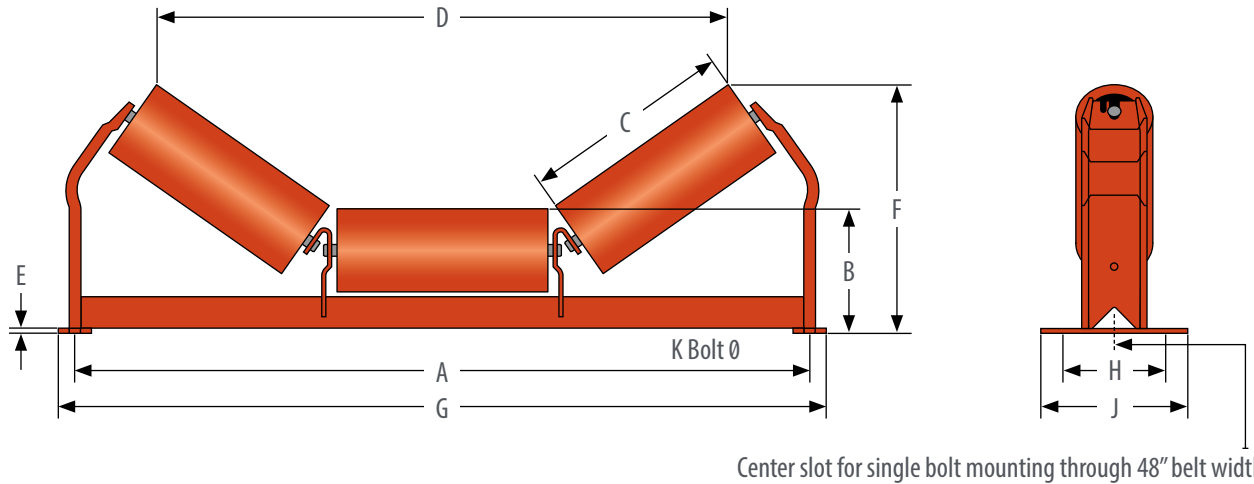

## TROUGHING IDLERS (EQUAL LENGTH ROLLERS): 4" AND 5" DIAMETER

	PART NUMBER		BW	B		C	D		E	F		G	H	J	K	WT (#)		
	4"	5"		4"	5"		4"	5"		4"	5"					4"	5"	
20°	B4-20E-14	B5-20E-14	14	23	6-15/16	7-7/16	6-1/16	18-15/16	18-9/16	3/16	9-1/8	9-9/16	25	6	8	1/2	25	30
	B4-20E-16	B5-20E-16	16	25	6-15/16	7-7/16	6-1/16	18-15/16	18-9/16	3/16	9-1/8	9-5/8	27	6	8	1/2	25	30
	B4-20E-18	B5-20E-18	18	27	6-15/16	7-7/16	7-1/16	21-3/4	21-7/16	3/16	9-7/16	9-7/8	29	6	8	1/2	27	33
	B4-20E-20	B5-20E-20	20	29	6-15/16	7-7/16	7-11/16	23-13/16	23-1/2	3/16	9-7/16	9-15/16	31	6	8	1/2	29	35
	B4-20E-24	B5-20E-24	24	33	6-15/16	7-7/16	9-1/16	27-1/2	27-3/16	3/16	10-1/8	10-9/16	35	6	8	1/2	32	39
	B4-20E-30	B5-20E-30	30	39	6-15/16	7-7/16	11-1/16	33-5/16	32-15/16	3/16	10-13/16	11-5/16	41	6	8	1/2	40	49
	B4-20E-36	B5-20E-36	36	45	6-15/16	7-7/16	13-1/16	39-1/16	38-11/16	3/16	11-1/2	12	47	6	8	1/2	46	56
	B4-20E-42	B5-20E-42	42	51	7-7/16	7-15/16	15-1/16	44-13/16	44-7/16	5/16	12-11/16	13-3/16	53	7-1/2	9-1/2	5/8	61	72
B4-20E-48	B5-20E-48	48	57	7-7/16	7-15/16	17-1/16	50-9/16	50-3/16	5/16	13-3/8	13-7/8	59	7-1/2	9-1/2	5/8	67	80	
35°	B4-35E-14	B5-35E-14	14	23	6-15/16	7-7/16	6-1/16	16-15/16	16-3/8	3/16	10-1/2	10-7/8	25	6	8	1/2	26	31
	B4-35E-16	B5-35E-16	16	25	6-15/16	7-7/16	6-1/16	16-15/16	16-3/8	3/16	10-1/2	10-7/8	27	6	8	1/2	26	31
	B4-35E-18	B5-35E-18	18	27	6-15/16	7-7/16	7-1/16	19-5/8	19	3/16	11-1/16	11-7/16	29	6	8	1/2	28	34
	B4-35E-20	B5-35E-20	20	29	6-15/16	7-7/16	7-11/16	21-13/16	21-5/16	3/16	11-1/8	11-9/16	31	6	8	1/2	30	36
	B4-35E-24	B5-35E-24	24	33	6-15/16	7-7/16	9-1/16	24-7/8	24-5/16	3/16	12-3/16	12-5/8	35	6	8	1/2	33	41
	B4-35E-30	B5-35E-30	30	39	6-15/16	7-7/16	11-1/16	30-3/16	29-9/16	3/16	13-3/8	13-13/16	41	6	8	1/2	42	50
	B4-35E-36	B5-35E-36	36	45	6-15/16	7-7/16	13-1/16	35-7/16	34-7/8	3/16	14-9/16	14-15/16	47	6	8	1/2	47	57
	B4-35E-42	B5-35E-42	42	51	7-7/16	7-15/16	15-1/16	40-11/16	40-1/8	5/16	16-3/16	16-9/16	53	7-1/2	9-1/2	5/8	62	74
B4-35E-48	B5-35E-48	48	57	7-7/16	7-15/16	17-1/16	46	45-3/8	5/16	17-5/16	17-3/4	59	7-1/2	9-1/2	5/8	69	82	
45°	B4-45E-18	B5-45E-18	18	27	6-15/16	7-7/16	7-1/16	18-3/16	17-1/2	3/16	11-7/8	12-1/4	29	6	8	1/2	29	35
	B4-45E-24	B5-45E-24	24	33	6-15/16	7-7/16	9-1/16	23	22-1/4	3/16	13-5/16	13-5/8	35	6	8	1/2	34	41
	B4-45E-30	B5-45E-30	30	39	6-15/16	7-7/16	11-1/16	27-13/16	27-1/8	3/16	14-3/4	15-1/8	41	6	8	1/2	42	51
	B4-45E-36	B5-45E-36	36	45	6-15/16	7-7/16	13-1/16	32-5/8	31-15/16	3/16	16-3/16	16-1/2	47	6	8	1/2	48	58
	B4-45E-42	B5-45E-42	42	51	7-7/16	7-15/16	15-1/16	37-1/2	36-3/4	5/16	18-1/8	18-7/16	53	7-1/2	9-1/2	5/8	63	75
	B4-45E-48	B5-45E-48	48	57	7-7/16	7-15/16	17-1/16	42-5/16	41-9/16	5/16	19-1/2	19-7/8	59	7-1/2	9-1/2	5/8	70	83

Recommended bolt pattern, see "Return & Flat Brackets Styles" section for minimum and maximum dimensions.



# CEMA B IDLERS

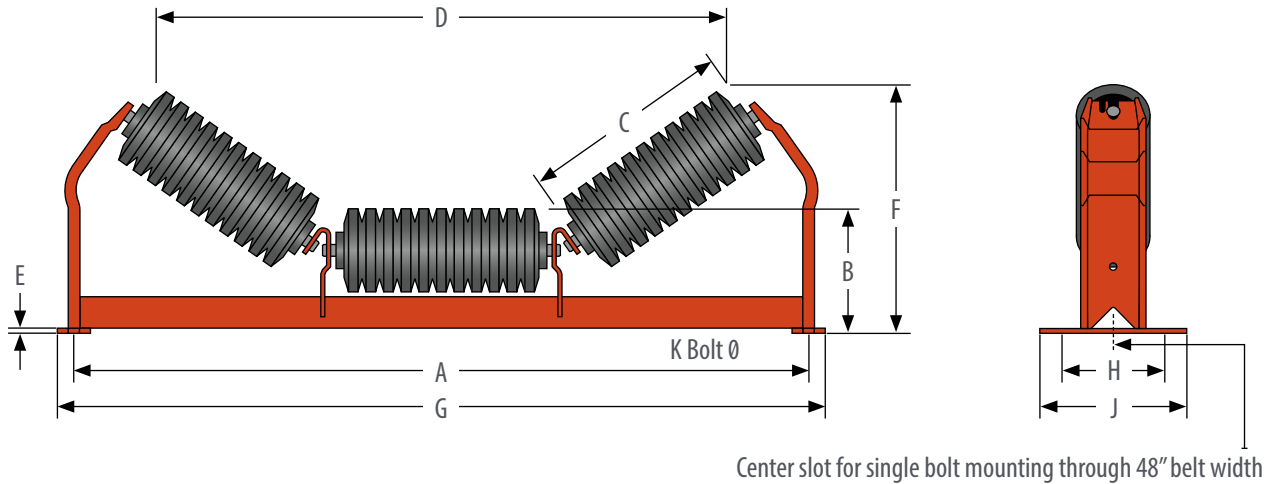

## RUBBER CUSHION IMPACT TROUGHING IDLERS: 4" AND 5" DIAMETER

	PART NUMBER		BW	B		C	D		E	F		G	H	J	K	WT (#)		
	4"	5"		4"	5"		4"	5"		4"	5"					4"	5"	
20°	B4-20EI-18	B5-20EI-18	18	27	6-15/16	7-7/16	7-1/8	20-1/2	20-3/16	3/16	9-1/4	9-3/4	29	6	8	1/2	31	36
	B4-20EI-24	B5-20EI-24	24	33	6-15/16	7-7/16	9-1/8	26-1/4	25-15/16	3/16	9-15/16	10-3/8	35	6	8	1/2	38	43
	B4-20EI-30	B5-20EI-30	30	39	6-15/16	7-7/16	11-1/8	32	31-3/4	3/16	10-5/8	11-1/8	41	6	8	1/2	47	54
	B4-20EI-36	B5-20EI-36	36	45	6-15/16	7-7/16	13-1/8	37-3/4	37-1/2	3/16	11-5/16	11-13/16	47	6	8	1/2	63	72
	B4-20EI-42	B5-20EI-42	42	51	7-7/16	7-15/16	15-1/8	43-9/16	43-1/4	5/16	12-1/2	13	53	7-1/2	9-1/2	1/2	80	90
	B4-20EI-48	B5-20EI-48	48	57	7-7/16	7-15/16	17-1/8	49-5/16	49	5/16	13-3/16	13-11/16	59	7-1/2	9-1/2	5/8	88	99
	B4-35EI-18	B5-35EI-18	18	27	6-15/16	7-7/16	7-1/8	18-7/16	17-15/16	3/16	10-3/4	11-3/16	29	6	8	1/2	32	36
35°	B4-35EI-24	B5-35EI-24	24	33	6-15/16	7-7/16	9-1/8	23-11/16	23-3/16	3/16	11-7/8	12-5/16	35	6	8	1/2	39	44
	B4-35EI-30	B5-35EI-30	30	39	6-15/16	7-7/16	11-1/8	29	28-7/16	3/16	13-1/16	13-1/2	41	6	8	1/2	48	55
	B4-35EI-36	B5-35EI-36	36	45	6-15/16	7-7/16	13-1/8	34-3/16	33-11/16	3/16	14-1/4	14-11/16	47	6	8	1/2	66	74
	B4-35EI-42	B5-35EI-42	42	51	7-7/16	7-15/16	15-1/8	39-1/2	38-15/16	5/16	15-15/16	16-5/16	53	7-1/2	9-1/2	5/8	83	92
	B4-35EI-48	B5-35EI-48	48	57	7-7/16	7-15/16	17-1/8	44-3/4	44-1/4	5/16	17-1/16	17-1/2	59	7-1/2	9-1/2	5/8	91	102
	B4-45EI-18	B5-45EI-18	18	27	6-15/16	7-7/16	7-1/8	17-1/8	16-1/2	3/16	11-1/2	11-7/8	29	6	8	1/2	34	37
	B4-45EI-24	B5-45EI-24	24	33	6-15/16	7-7/16	9-1/8	25-15/16	21-5/16	3/16	12-7/8	13-3/16	35	6	8	1/2	39	45
45°	B4-45EI-30	B5-45EI-30	30	39	6-15/16	7-7/16	11-1/8	26-13/16	26-1/8	3/16	14-5/16	14-11/16	41	6	8	1/2	49	56
	B4-45EI-36	B5-45EI-36	36	45	6-15/16	7-7/16	13-1/8	31-1/2	30-13/16	3/16	15-13/16	16-13/16	47	6	8	1/2	68	76
	B4-45EI-42	B5-45EI-42	42	51	7-7/16	7-15/16	15-1/8	37-7/16	35-3/4	5/16	17-11/16	18-1/16	53	7-1/2	9-1/2	5/8	85	94
	B4-45EI-48	B5-45EI-48	48	57	7-7/16	7-15/16	17-1/8	41-1/2	40-9/16	5/16	19-1/16	19-1/2	59	7-1/2	9-1/2	5/8	93	104

Belt Width (Reinforcing on 36" BW - 48" BW Impact Frame.)

Recommended bolt pattern, see "Return & Flat Brackets Styles" section for minimum and maximum dimensions.

All weights include brackets, individual bracket weights are listed on "Return & Flat Brackets Styles" section. Brackets sold separately.

# CEMA B IDLERS

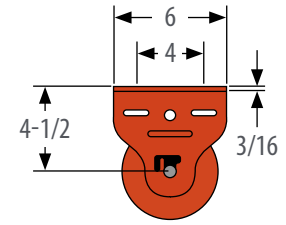
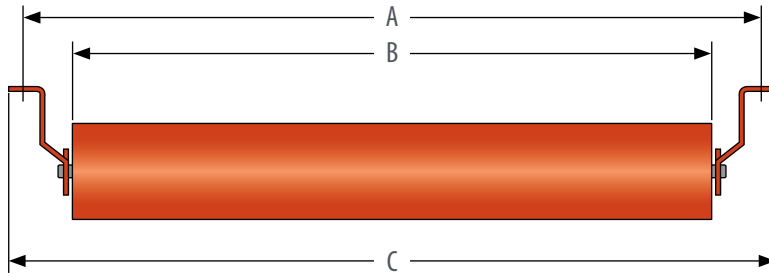

SLOTTED FOR 1/2" Ø BOLT

## RETURN IDLERS: 4" AND 5" DIAMETER

PART NUMBER		BW	A	B	C	WT (#)	
4"	5"					4"	5"
B4-RET-14	B5-RET-14	14	23	17-3/8	24-7/16	14	18
B4-RET-16	B5-RET-16	16	25	19-3/8	26-7/16	15	20
B4-RET-18	B5-RET-18	18	27	21-3/8	28-7/16	16	21
B4-RET-20	B5-RET-20	20	29	23-3/8	30-7/16	17	23
B4-RET-24	B5-RET-24	24	33	27-3/8	34-7/16	19	26
B4-RET-30	B5-RET-30	30	39	33-3/8	40-7/16	22	30
B4-RET-36	B5-RET-36	36	45	39-3/8	46-7/16	25	35
B4-RET-42	B5-RET-42	42	51	45-3/8	52-7/16	29	39
B4-RET-48	B5-RET-48	48	57	51-3/8	58-7/16	32	44

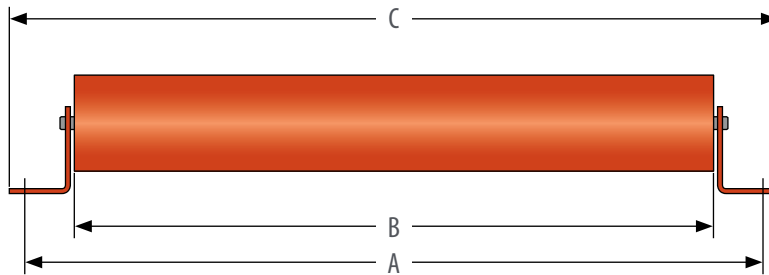

SLOTTED FOR 1/2" Ø BOLT

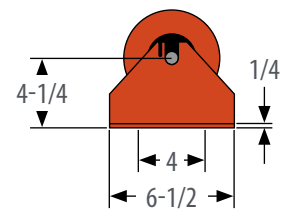

## FLAT IDLERS: 4" AND 5" DIAMETER

PART NUMBER		BW	A	B	C	WT (#)	
4"	5"					4"	5"
B4-FLT-14	B5-FLT-14	14	23	17-3/8	24-15/16	16	21
B4-FLT-16	B5-FLT-16	16	25	19-3/8	26-15/16	18	22
B4-FLT-18	B5-FLT-18	18	27	21-3/4	28-15/16	19	24
B4-FLT-20	B5-FLT-20	20	29	23-3/8	30-15/16	20	25
B4-FLT-24	B5-FLT-24	24	33	27-3/8	34-15/16	22	28
B4-FLT-30	B5-FLT-30	30	39	33-3/8	40-15/16	25	33
B4-FLT-36	B5-FLT-36	36	45	39-3/8	46-15/16	28	37
B4-FLT-42	B5-FLT-42	42	51	45-3/8	52-15/16	31	42
B4-FLT-48	B5-FLT-48	48	57	51-3/8	58-15/16	34	46

All weights include brackets, individual bracket weights are listed on "Return & Flat Brackets Styles" section. Brackets sold separately.

# CEMA B IDLERS

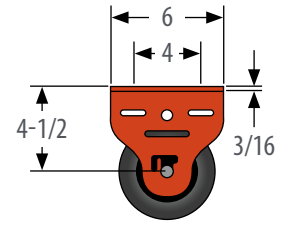
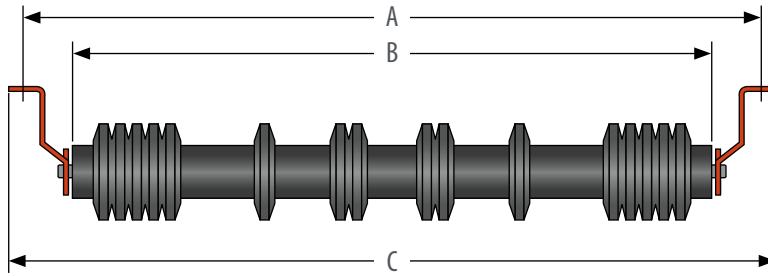

SLOTTED FOR 1/2" Ø BOLT

## RUBBER CUSHION RETURN IDLERS: 4" AND 5"

PART NUMBER		BW	A	B	C	WT (#)	
4"	5"					4"	5"
B4-RETI-18	B5-RETI-18	18	27	21-7/16	28-7/16	19	21
B4-RETI-20	B5-RETI-20	20	29	23-7/16	30-7/16	20	23
B4-RETI-24	B5-RETI-24	24	33	27-7/16	34-7/16	23	26
B4-RETI-30	B5-RETI-30	30	39	33-7/16	40-7/16	26	30
B4-RETI-36	B5-RETI-36	36	45	39-7/16	46-7/16	30	34
B4-RETI-42	B5-RETI-42	42	51	45-7/16	52-7/16	34	38
B4-RETI-48	B5-RETI-48	48	57	51-7/16	58-7/16	37	41

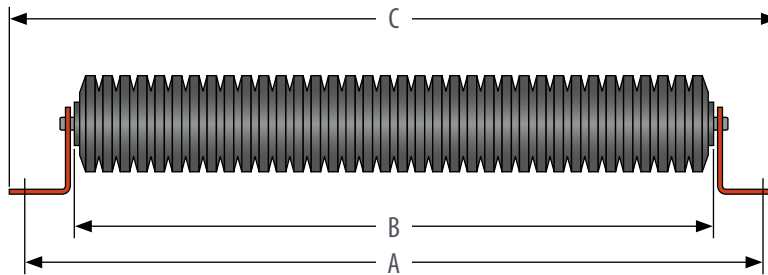

SLOTTED FOR 1/2" Ø BOLT

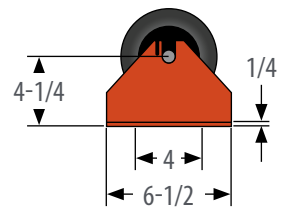

## RUBBER CUSHION FLAT IDLERS: 4" AND 5"

PART NUMBER		BW	A	B	C	WT (#)	
4"	5"					4"	5"
B4-FLTI-18	B5-FLTI-18	18	27	21-7/16	28-15/16	23	28
B4-FLTI-24	B5-FLTI-24	24	33	27-7/16	34-15/16	28	34
B4-FLTI-30	B5-FLTI-30	30	39	33-7/16	40-15/16	33	40
B4-FLTI-36	B5-FLTI-36	36	45	39-7/16	46-15/16	37	46
B4-FLTI-42	B5-FLTI-42	42	51	45-7/16	52-15/16	42	52
B4-FLTI-48	B5-FLTI-48	48	57	51-7/16	58-15/16	47	59

All weights include brackets, individual bracket weights are listed on "Return & Flat Brackets Styles" section. Brackets sold separately.

# CEMA B IDLERS

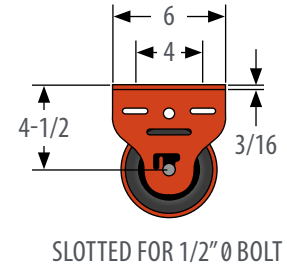
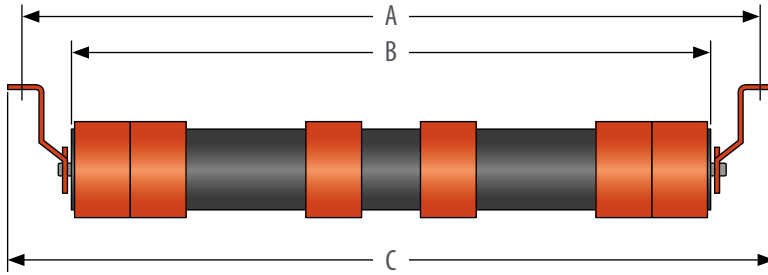

## URATHON® RETURN ROLL: 5" DIAMETER

PART NUMBER	BW	A	B	C	WT (#)
B5-RETU-18	18	27	21-3/8	28-7/16	21
B5-RETU-24	24	33	27-3/8	34-7/16	24
B5-RETU-30	30	39	33-3/8	40-7/16	28
B5-RETU-36	36	45	39-3/8	46-7/16	32
B5-RETU-42	42	51	45-3/8	52-7/16	36
B5-RETU-48	48	57	51-3/8	58-7/16	40

Spiral Urathon is only available in 6" diameter.

All weights include brackets, individual bracket weights are listed on "Return & Flat Brackets Styles" section. Brackets sold separately.

# CEMA B IDLERS

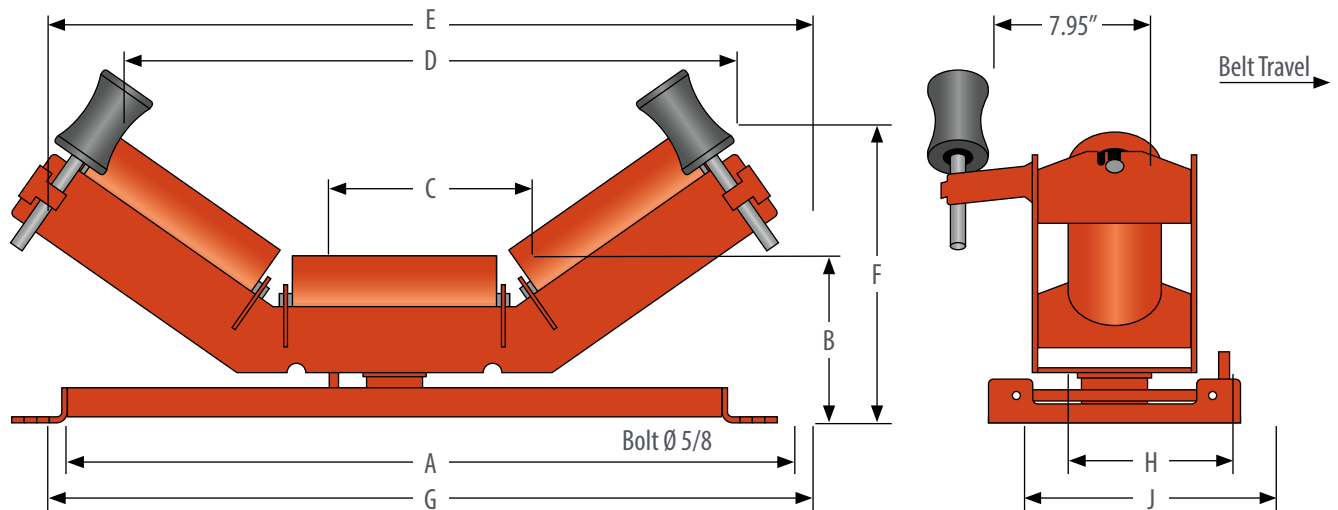

## SELF-ALIGNING TROUGHING IDLERS: 4" AND 5"

PART NUMBER		BW	A	B		C	D		E	F		G	H	J	WT (#)		
4"	5"			4"	5"		4"	5"		4"	5"				4"	5"	4"
20°	B4-20EA-18	B5-20EA-18	18	27	7-1/2	8	6-7/8	23	22-7/8	31-1/4	10-1/4	10-11/16	28-3/4	6	11-1/2	85	91
	B4-20EA-24	B5-20EA-24	24	33	7-1/2	8	8-7/8	28-13/16	22-5/8	37	10-15/16	11-3/8	34-3/4	6	11-1/2	96	103
	B4-20EA-30	B5-20EA-30	30	39	7-1/2	8	10-7/8	34-9/16	34-3/8	42-3/4	11-5/8	12-1/16	40-3/4	6	11-1/2	106	115
	B4-20EA-36	B5-20EA-36	36	45	7-1/2	8	12-7/8	40-5/16	40-1/8	48-1/2	12-1/4	12-3/4	46-3/4	6	11-1/2	117	127
	B4-20EA-42	B5-20EA-42	42	51	8	8-1/2	14-7/8	45-7/8	45-3/4	54-1/16	13-7/16	13-15/16	52-3/4	7-1/2	11-1/2	131	142
	B4-20EA-48	B5-20EA-48	48	57	8	8-1/2	16-7/8	51-11/16	51-1/2	59-11/16	14-1/8	14-5/8	58-3/4	7-1/2	11-1/2	142	156
35°	B4-35EA-18	B5-35EA-18	18	27	7-1/2	8	6-7/8	19-15/16	19-9/16	30-9/16	11-7/8	12-1/4	28-3/4	6	11-1/2	86	92
	B4-35EA-24	B5-35EA-24	24	33	7-1/2	8	8-7/8	25-3/16	24-7/8	35-13/16	13	13-3/8	34-3/4	6	11-1/2	97	104
	B4-35EA-30	B5-35EA-30	30	39	7-1/2	8	10-7/8	30-1/2	30-1/8	41-1/16	14-1/8	14-9/16	40-3/4	6	11-1/2	107	115
	B4-35EA-36	B5-35EA-36	36	45	7-1/2	8	12-7/8	35-3/4	35-7/16	46-3/8	15-5/16	15-11/16	46-3/4	6	11-1/2	117	127
	B4-35EA-42	B5-35EA-42	42	51	8	8-1/2	14-7/8	40-11/16	40-3/8	51-5/16	16-15/16	17-3/8	52-3/4	7-1/2	11-1/2	132	143
	B4-35EA-48	B5-35EA-48	48	57	8	8-1/2	16-7/8	46	45-5/8	56-5/8	18-1/16	18-1/2	58-3/4	7-1/2	11-1/2	143	155
45°	B4-45EA-18	B5-45EA-18	18	27	7-1/2	8	6-7/8	19-1/2	18-3/4	30-11/16	12-3/4	13-1/16	28-3/4	6	11-1/2	87	93
	B4-45EA-24	B5-45EA-24	24	33	7-1/2	8	8-7/8	24-5/16	23-9/16	35-1/2	14-3/16	14-1/2	34-3/4	6	11-1/2	98	105
	B4-45EA-30	B5-45EA-30	30	39	7-1/2	8	10-7/8	29-3/16	28-3/8	40-5/16	15-5/8	15-15/16	40-3/4	6	11-1/2	108	117
	B4-45EA-36	B5-45EA-36	36	45	7-1/2	8	12-7/8	34	33-3/16	45-3/16	17	17-5/16	46-3/4	6	11-1/2	119	128
	B4-45EA-42	B5-45EA-42	42	51	8	8-1/2	14-7/8	38-7/16	37-5/8	50-1/4	18-15/16	19-1/4	52-3/4	7-1/2	11-1/2	133	144
	B4-45EA-48	B5-45EA-48	48	57	8	8-1/2	16-7/8	43-1/4	42-7/16	55-1/8	20-3/8	20-5/8	58-3/4	7-1/2	11-1/2	144	157

# CEMA B IDLERS

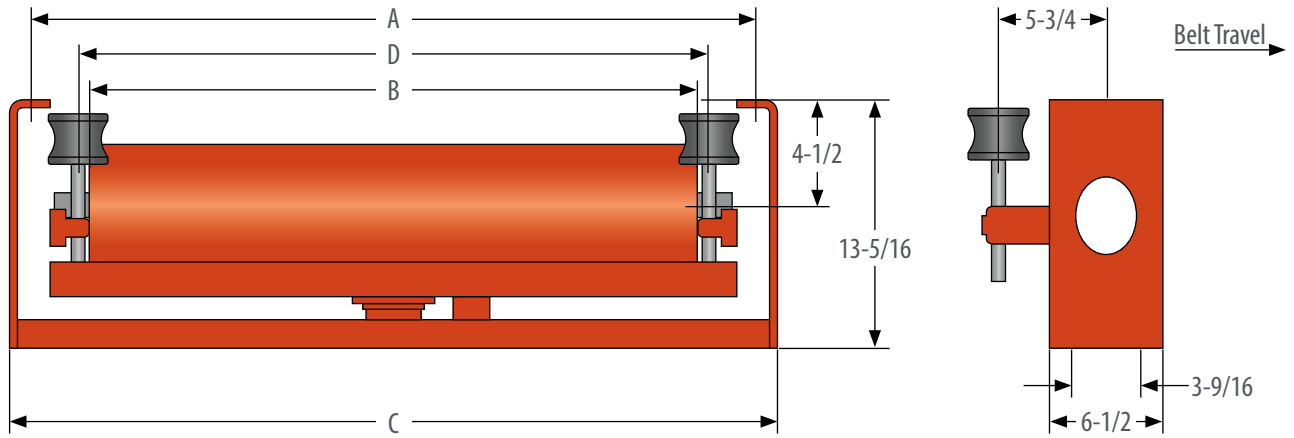

## SELF-ALIGNING RETURN IDLERS: 4" AND 5" DIAMETER

PART NUMBER		BW	A	B	C	D	WT (#)	
4"	5"						4"	5"
B4-RETA-18	B5-RETA-18	18	27	21-3/8	29-1/2	25-5/8	62	68
B4-RETA-24	B5-RETA-24	24	33	27-3/8	35-1/2	31-5/8	70	77
B4-RETA-30	B5-RETA-30	30	39	33-3/8	41-1/2	37-5/8	80	88
B4-RETA-36	B5-RETA-36	36	45	39-3/8	47-1/2	43-5/8	88	97
B4-RETA-42	B5-RETA-42	42	51	45-3/8	53-1/2	49-5/8	104	115
B4-RETA-48	B5-RETA-48	48	57	51-3/8	59-1/2	55-5/8	113	125

Also available in bi-directional. Designated by "BA".

All weights include brackets only applies to RET, RETI, FLT or FLTI.

Individual bracket weights are listed on "Return & Flat Brackets Styles" section. Brackets sold separately.

# CEMA B IDLERS

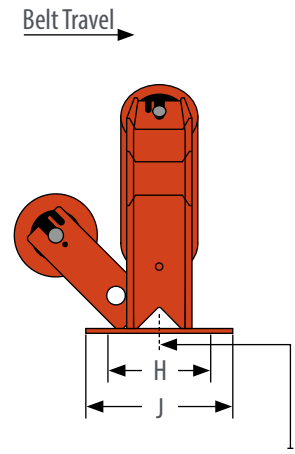
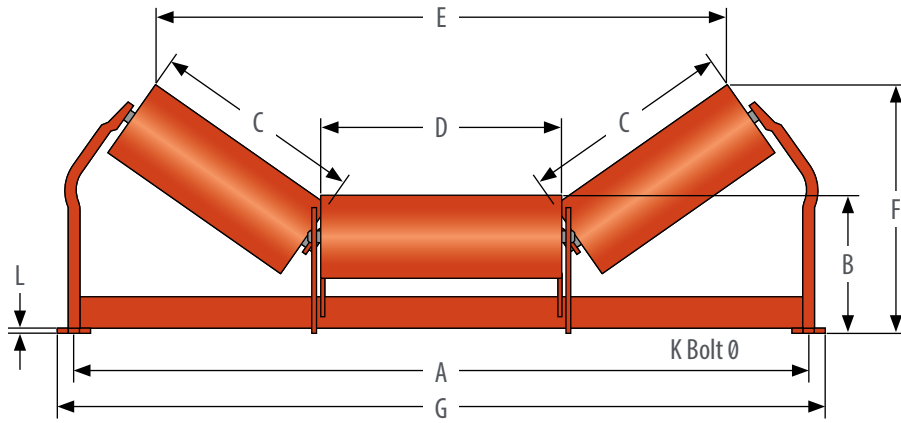

Center slot for single bolt mounting through 48" belt width

## OFFSET CENTER ROLL IDLERS: 4" AND 5" DIAMETER

	PART NUMBER		BW	A	B		C	D	E		F		G	H	J	K	L	WT (#)	
	4"	5"			4"	5"			4"	5"	4"	5"						4"	5"
20°	B4-20GO-18	B5-20GO-18	18	27	7-3/16	7-11/16	7-1/16	9-1/16	21-11/16	21-7/16	9-3/8	9-7/8	29	6	8	1/2	3/16	31	37
	B4-20GO-24	B5-20GO-24	24	33	7-3/16	7-11/16	9-1/16	11-1/16	27-7/16	27-3/16	10-1/16	10-9/16	35	6	8	1/2	3/16	36	43
	B4-20GO-30	B5-20GO-30	30	39	7-3/16	7-11/16	11-1/16	13-1/16	33-3/16	32-15/16	10-13/16	11-5/16	41	6	8	1/2	3/16	43	52
	B4-20GO-36	B5-20GO-36	36	45	7-3/16	7-11/16	13-1/16	15-1/16	39	38-11/16	11-1/2	12	47	6	8	1/2	5/16	49	59
	B4-20GO-42	B5-20GO-42	42	51	7-11/16	8-3/16	15-1/16	17-1/16	44-3/4	44-7/16	12-11/16	13-3/16	53	7-1/2	9-1/2	5/8	5/16	64	76
	B4-20GO-48	B5-20GO-48	48	57	7-11/16	8-3/16	17-1/16	19-1/16	50-1/2	50-3/16	13-3/8	13-7/8	59	7-1/2	9-1/2	5/8	5/16	70	84
35°	B4-35GO-18	B5-35GO-18	18	27	7-1/16	7-9/16	7-1/16	9-1/16	19-5/8	19	11-1/16	11-7/16	29	6	8	1/2	3/16	32	38
	B4-35GO-24	B5-35GO-24	24	33	7-1/16	7-9/16	9-1/16	11-1/16	24-7/8	24-5/16	12-3/16	12-5/8	35	6	8	1/2	3/16	37	44
	B4-35GO-30	B5-35GO-30	30	39	7-1/8	7-5/8	11-1/16	13-1/16	30-3/16	29-9/16	13-3/16	13-13/16	41	6	8	1/2	3/16	45	54
	B4-35GO-36	B5-35GO-36	36	45	7-1/8	7-5/8	13-1/16	15-1/16	35-7/16	34-7/8	14-9/16	14-15/16	47	6	8	1/2	5/16	50	61
	B4-35GO-42	B5-35GO-42	42	51	7-5/8	8-1/8	15-1/16	17-1/16	40-11/16	40-1/8	16-3/16	16-9/16	53	7-1/2	9-1/2	5/8	5/16	66	78
	B4-35GO-48	B5-35GO-48	48	57	7-5/8	8-1/8	17-1/16	19-1/16	46	45-3/8	17-5/16	17-3/4	59	7-1/2	9-1/2	5/8	5/16	72	86
45°	B4-45GO-18	B5-45GO-18	18	27	7-1/4	7-3/4	7-1/16	9-1/16	18-3/16	17-7/16	11-7/8	12-1/4	29	6	8	1/2	3/16	32	38
	B4-45GO-24	B5-45GO-24	24	33	7-1/4	7-3/4	9-1/16	11-1/16	23	22-1/4	13-5/16	13-5/8	35	6	8	1/2	3/16	37	45
	B4-45GO-30	B5-45GO-30	30	39	7-5/16	7-13/16	11-1/16	13-1/16	27-13/16	27-1/8	14-3/4	15-1/8	41	6	8	1/2	3/16	46	55
	B4-45GO-36	B5-45GO-36	36	45	7-5/16	7-13/16	13-1/16	15-1/16	32-5/8	31-15/16	16-3/16	16-1/2	47	6	8	1/2	5/16	51	62
	B4-45GO-42	B5-45GO-42	42	51	7-7/16	7-15/16	15-1/16	17-1/16	37-1/2	36-3/4	18-1/16	18-7/16	53	7-1/2	9-1/2	5/8	5/16	67	79
	B4-45GO-48	B5-45GO-48	48	57	7-7/16	7-15/16	17-1/16	19-3/8	42-5/16	41-9/16	19-1/2	19-15/16	59	7-1/2	9-1/2	5/8	5/16	74	87

Recommended bolt pattern, see "Return & Flat Brackets Styles" section for minimum and maximum dimensions.

# CEMA B IDLERS

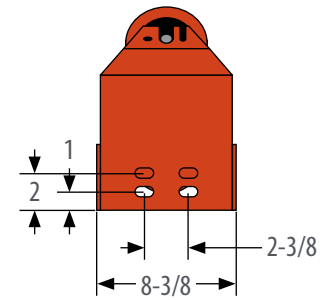
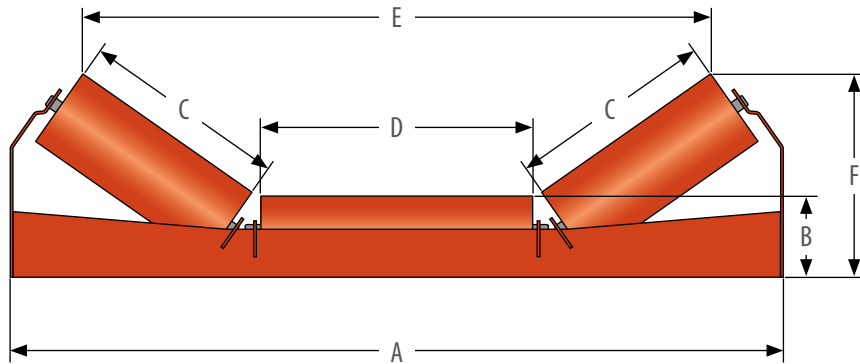

SLOTTED FOR 1/2" Ø BOLT

## CHANNEL MOUNT: 4" AND 5" DIAMETER

	PART NUMBER		BW	A	B		C	D	E		F		WT (#)	
	4"	5"			4"	5"			4"	5"	4"	5"	4"	5"
20°	B4-20CM-18	B5-20CM-18	18	23-5/8	4-7/16	4-15/16	5-7/8	6-7/8	20-1/8	19-3/4	6-9/16	7	34	39
	B4-20CM-24	B5-20CM-24	24	29-5/8	4-7/16	4-15/16	6-7/8	10-7/8	26-1/16	25-3/4	6-7/8	7-3/8	40	47
	B4-20CM-30	B5-20CM-30	30	35-5/8	4-7/16	4-15/16	8-7/8	12-7/8	31-13/16	31-7/16	7-9/16	8-1/16	49	57
	B4-20CM-36	B5-20CM-36	36	41-5/8	4-7/16	4-15/16	10-7/8	14-7/8	37-5/8	37-1/4	8-1/4	8-3/4	60	70
	B4-20CM-42	B5-20CM-42	42	47-5/8	4-7/16	4-15/16	12-7/8	16-7/8	43-3/8	43-1/16	8-15/16	9-7/16	70	80
	B4-20CM-48	B5-20CM-48	48	53-5/8	4-7/16	4-15/16	14-7/8	18-7/8	49	48-11/16	9-5/8	10-1/8	77	89
35°	B4-35CM-18	B5-35CM-18	18	23-5/8	4-7/16	4-15/16	5-7/8	6-7/8	18-1/16	17-1/2	8	8-3/8	37	42
	B4-35CM-24	B5-35CM-24	24	29-5/8	4-7/16	4-15/16	6-7/8	10-7/8	23-3/4	23-1/4	8-5/8	8-15/16	44	51
	B4-35CM-30	B5-35CM-30	30	35-5/8	4-7/16	4-15/16	8-7/8	12-7/8	29	28-7/16	9-3/4	10-1/8	52	60
	B4-35CM-36	B5-35CM-36	36	41-5/8	4-7/16	4-15/16	10-7/8	14-7/8	34-3/8	33-7/8	10-15/16	11-1/4	65	74
	B4-35CM-42	B5-35CM-42	42	47-5/8	4-7/16	4-15/16	12-7/8	16-7/8	39-1/2	39	12-1/16	12-3/8	73	84
	B4-35CM-48	B5-35CM-48	48	53-5/8	4-7/16	4-15/16	14-7/8	18-7/8	44-3/4	44-3/16	13-3/16	13-9/16	81	93

Also available in standard mount designated by "SM".



# CEMA B IDLERS

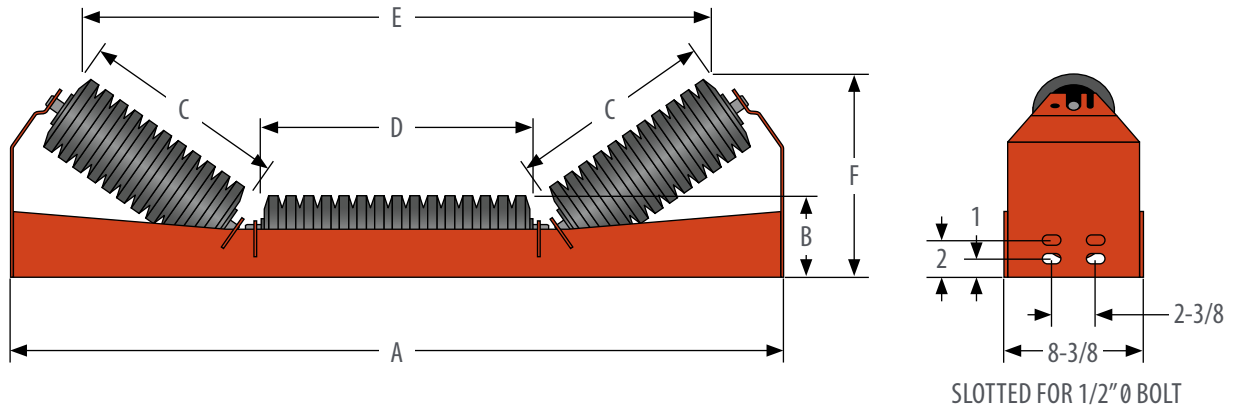

## CHANNEL MOUNT IMPACT IDLERS: 4" AND 5" DIAMETER

PART NUMBER		BW	A	B		C	D	E		F		WT (#)	
4"	5"			4"	5"			4"	5"	4"	5"	4"	5"
B4-20CMI-18	B5-20CMI-18	18	23-5/8	4-7/16	4-15/16	5-15/16	6-15/16	18-7/8	18-1/2	6-7/16	6-7/8	36	40
B4-20CMI-24	B5-20CMI-24	24	29-5/8	4-7/16	4-15/16	6-15/16	10-15/16	24-7/8	24-1/2	6-13/16	7-1/4	44	50
B4-20CMI-30	B5-20CMI-30	30	35-5/8	4-7/16	4-15/16	8-15/16	12-15/16	30-5/8	30-1/4	7-7/16	7-15/16	54	60
B4-20CMI-36	B5-20CMI-36	36	41-5/8	4-7/16	4-15/16	10-15/16	14-15/16	36-3/8	36-1/16	8-1/8	8-5/8	67	75
B4-20CMI-42	B5-20CMI-42	42	47-5/8	4-7/16	4-15/16	12-15/16	16-15/16	42-1/8	41-13/16	8-13/16	9-5/16	78	87
B4-20CMI-48	B5-20CMI-48	48	53-5/8	4-7/16	4-15/16	14-15/16	18-15/16	47-7/8	47-9/16	9-1/2	9-15/16	87	97
B4-35CMI-18	B5-35CMI-18	18	23-5/8	4-7/16	4-15/16	5-15/16	6-15/16	17-1/16	16-1/2	7-11/16	8-1/8	39	43
B4-35CMI-24	B5-35CMI-24	24	29-5/8	4-7/16	4-15/16	6-15/16	10-15/16	22-13/16	22-1/4	8-5/16	8-11/16	48	53
B4-35CMI-30	B5-35CMI-30	30	35-5/8	4-7/16	4-15/16	8-15/16	12-15/16	28-1/16	27-1/2	9-7/16	9-7/8	57	64
B4-35CMI-36	B5-35CMI-36	36	41-5/8	4-7/16	4-15/16	10-15/16	14-15/16	33-3/8	32-13/16	10-5/8	11	71	79
B4-35CMI-42	B5-35CMI-42	42	47-5/8	4-7/16	4-15/16	12-15/16	16-15/16	38-5/8	38-1/16	11-3/4	12-3/16	81	90
B4-35CMI-48	B5-35CMI-48	48	53-5/8	4-7/16	4-15/16	14-15/16	18-15/16	43-15/16	43-5/16	12-15/16	13-5/16	91	101

20°

35°

Also available in standard mount designated by "SM".

# CEMA C IDLERS

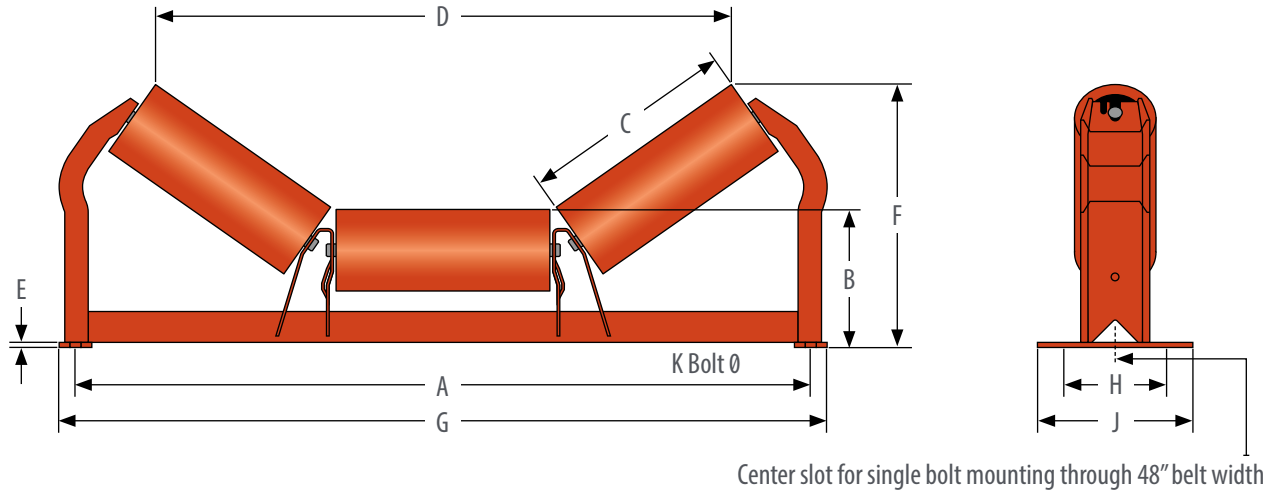

## TROUGHING IDLERS (EQUAL LENGTH ROLLERS): 4" DIAMETER

	PART NUMBER	BW	A	B	C	D	E	F	G	H	J	K	WT (#)
20°	C4-20E-18	18	27	7-13/16	6-15/16	22-3/16	3/16	10-5/16	29	6	8	1/2	33
	C4-20E-24	24	33	7-15/16	8-15/16	27-15/16	5/16	11-1/16	35	6	9-1/2	5/8	40
	C4-20E-30	30	39	7-15/16	10-15/16	33-11/16	5/16	11-13/16	41	6	9-1/2	5/8	48
	C4-20E-36	36	45	7-15/16	12-15/16	39-7/16	5/16	12-1/2	47	6	9-1/2	5/8	54
	C4-20E-42	42	51	8-5/16	14-15/16	45-3/16	5/16	13-9/16	53	7-1/2	9-1/2	5/8	68
	C4-20E-48	48	57	8-5/16	16-15/16	51	5/16	14-1/4	59	7-1/2	9-1/2	5/8	75
	C4-20E-54	54	63	8-3/4	18-15/16	56-3/4	3/8	15-5/16	65-1/2	9	11	5/8	90
	C4-20E-60	60	69	8-3/4	20-15/16	62-1/2	3/8	16	71-1/2	9	11	5/8	97
35°	C4-35E-18	18	27	7-13/16	6-15/16	20-1/16	3/16	12	29	6	8	1/2	35
	C4-35E-24	24	33	7-15/16	8-15/16	25-5/16	5/16	13-5/16	35	6	9-1/2	5/8	42
	C4-35E-30	30	39	7-15/16	10-15/16	30-9/16	5/16	14-7/16	41	6	9-1/2	5/8	50
	C4-35E-36	36	45	7-15/16	12-15/16	35-7/8	5/16	15-5/8	47	6	9-1/2	5/8	56
	C4-35E-42	42	51	8-5/16	14-15/16	41-1/8	5/16	17-1/8	53	7-1/2	9-1/2	5/8	64
	C4-35E-48	48	57	8-5/16	16-15/16	46-3/8	5/16	18-5/16	59	7-1/2	9-1/2	5/8	78
	C4-35E-54	54	63	8-3/4	18-15/16	51-11/16	3/8	19-7/8	65-1/2	9	11	5/8	93
	C4-35E-60	60	69	8-3/4	20-15/16	56-15/16	3/8	21	71-1/2	9	11	5/8	101
45°	C4-45E-18	18	27	7-13/16	6-15/16	18-3/4	3/16	13-1/8	29	6	8	1/2	36
	C4-45E-24	24	33	7-15/16	8-15/16	23-9/16	5/16	14-5/8	35	6	9-1/2	5/8	43
	C4-45E-30	30	39	7-15/16	10-15/16	28-7/16	5/16	16-1/16	41	6	9-1/2	5/8	52
	C4-45E-36	36	45	7-15/16	12-15/16	33-1/4	5/16	17-1/2	47	6	9-1/2	5/8	58
	C4-45E-42	42	51	8-5/16	14-15/16	38-1/16	5/16	19-5/16	53	7-1/2	9-1/2	5/8	73
	C4-45E-48	48	57	8-5/16	16-15/16	42-15/16	5/16	20-11/16	59	7-1/2	9-1/2	5/8	80
	C4-45E-54	54	63	8-3/4	18-15/16	47-3/4	3/8	22-1/2	65-1/2	9	11	5/8	96
	C4-45E-60	60	69	8-3/4	20-15/16	52-9/16	3/8	23-15/16	71-1/2	9	11	5/8	104

Add "TTM", "DRY", "WET", "LOW" to the end of the part number to add application specific seals.

Add "MOX" to the end of the part number to replace steel cans with Moxie Rolls.

Recommended bolt pattern, see "Return & Flat Brackets Styles" section for minimum and maximum dimensions.

Individual bracket weights are listed on "Return & Flat Brackets Styles" section. Brackets sold separately.

# CEMA C IDLERS

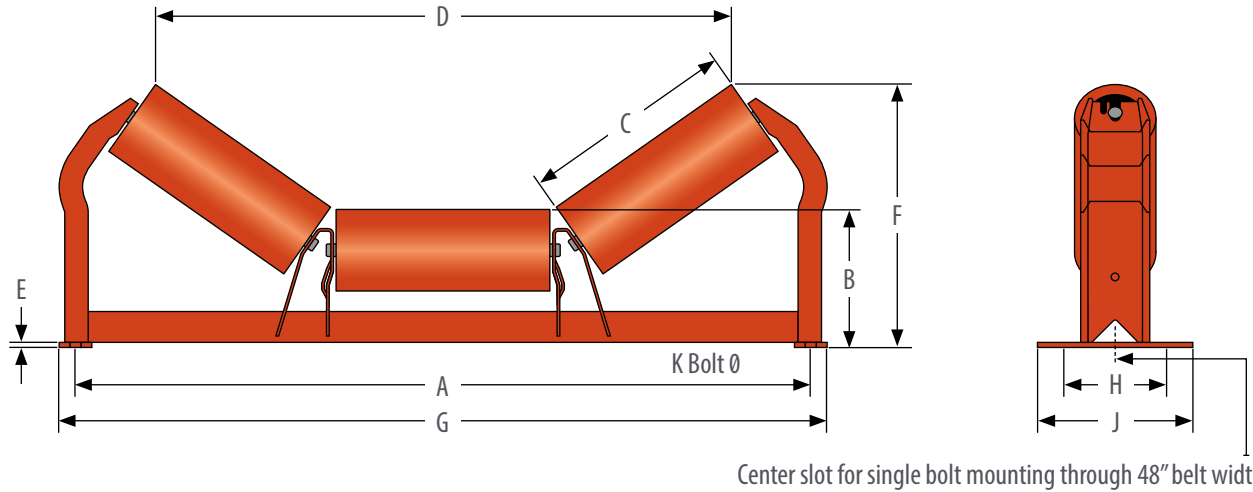

## TROUGHING IDLERS (EQUAL LENGTH ROLLERS): 5" DIAMETER

	PART NUMBER	BW	A	B	C	D	E	F	G	H	J	K	WT (#)
20°	CS-20E-18	18	27	8-5/16	6-15/16	21-7/8	3/16	10-3/4	29	6	8	1/2	39
	CS-20E-24	24	33	8-7/16	8-15/16	27-5/8	5/16	11-9/16	35	6	9-1/2	5/8	47
	CS-20E-30	30	39	8-7/16	10-15/16	33-7/16	5/16	12-5/16	41	6	9-1/2	5/8	57
	CS-20E-36	36	45	8-7/16	12-15/16	39-3/16	5/16	12-15/16	47	6	9-1/2	5/8	64
	CS-20E-42	42	51	8-13/16	14-15/16	44-15/16	5/16	14-1/16	53	7-1/2	9-1/2	5/8	80
	CS-20E-48	48	57	8-13/16	16-15/16	50-11/16	5/16	14-3/4	59	7-1/2	9-1/2	5/8	88
	CS-20E-54	54	63	9-1/4	18-15/16	56-7/16	3/8	15-13/16	65-1/2	9	11	5/8	104
	CS-20E-60	60	69	9-1/4	20-15/16	63-3/16	3/8	16-1/2	71-1/2	9	11	5/8	113
35°	CS-35E-18	18	27	8-5/16	6-15/16	19-9/16	3/16	12-7/16	29	6	8	1/2	41
	CS-35E-24	24	33	8-7/16	8-15/16	24-13/16	5/16	13-11/16	35	6	9-1/2	5/8	49
	CS-35E-30	30	39	8-7/16	10-15/16	30-1/16	5/16	14-7/8	41	6	9-1/2	5/8	59
	CS-35E-36	36	45	8-7/16	12-15/16	35-3/8	5/16	16-1/16	47	6	9-1/2	5/8	67
	CS-35E-42	42	51	8-13/16	14-15/16	40-5/8	5/16	17-9/16	53	7-1/2	9-1/2	5/8	82
	CS-35E-48	48	57	8-13/16	16-15/16	45-15/16	5/16	18-11/16	59	7-1/2	9-1/2	5/8	91
	CS-35E-54	54	63	9-1/4	18-15/16	51-1/8	3/8	20-1/4	65-1/2	9	11	5/8	108
	CS-35E-60	60	69	9-1/4	20-15/16	56-7/16	3/8	21-7/16	71-1/2	9	11	5/8	117
45°	CS-45E-18	18	27	8-5/16	6-15/16	18-1/16	3/16	13-7/16	29	6	8	1/2	42
	CS-45E-24	24	33	8-7/16	8-15/16	22-7/8	5/16	15	35	6	9-1/2	5/8	50
	CS-45E-30	30	39	8-7/16	10-15/16	27-13/16	5/16	16-7/16	41	6	9-1/2	5/8	61
	CS-45E-36	36	45	8-7/16	12-15/16	32-9/16	5/16	17-7/8	47	6	9-1/2	5/8	68
	CS-45E-42	42	51	8-13/16	14-15/16	37-7/16	5/16	19-5/8	53	7-1/2	9-1/2	5/8	84
	CS-45E-48	48	57	8-13/16	16-15/16	42-1/4	5/16	21-1/16	59	7-1/2	9-1/2	5/8	93
	CS-45E-54	54	63	9-1/4	18-15/16	47-1/16	3/8	22-7/8	65-1/2	9	11	5/8	110
	CS-45E-60	60	69	9-1/4	20-15/16	51-7/16	3/8	27-5/16	71-1/2	9	11	5/8	120

Add "TTM", "DRY", "WET", "LOW" to the end of the part number to add application specific seals.

Add "MOX" to the end of the part number to replace steel cans with Moxie Rolls.

Recommended bolt pattern, see "Return & Flat Brackets Styles" section for minimum and maximum dimensions.

Individual bracket weights are listed on "Return & Flat Brackets Styles" section. Brackets sold separately.

# CEMA C IDLERS

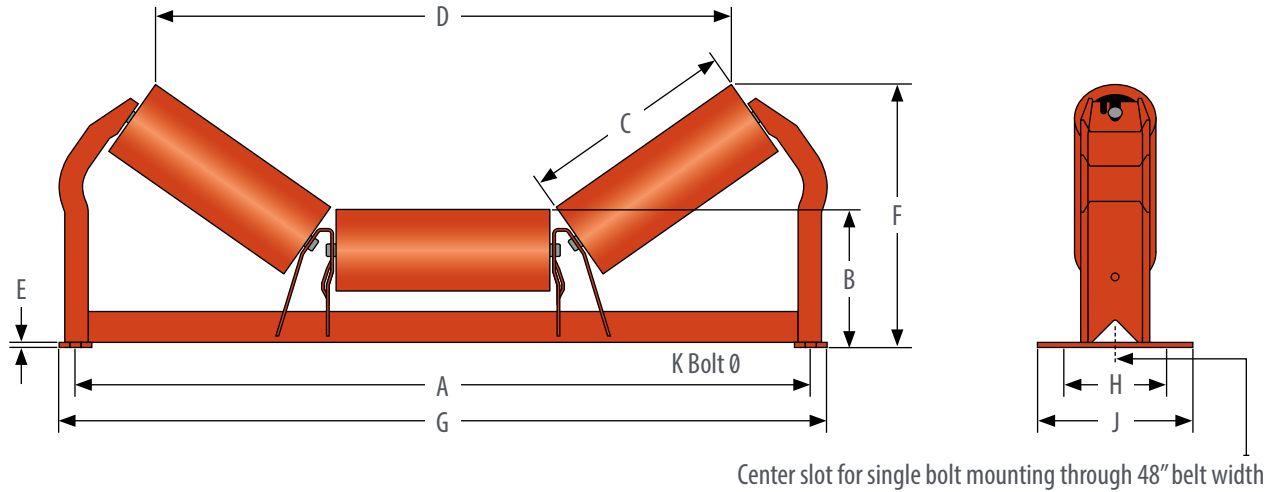

## TROUGHING IDLERS (EQUAL LENGTH ROLLERS): 6" DIAMETER

	PART NUMBER	BW	A	B	C	D	E	F	G	H	J	K	WT (#)
20°	C6-20E-18	18	27	8-13/16	6-15/16	21-9/16	3/16	11-1/4	29	6	8	1/2	46
	C6-20E-24	24	33	8-15/16	8-15/16	27-5/16	5/16	12-1/16	35	6	9-1/2	5/8	57
	C6-20E-30	30	39	8-15/16	10-15/16	33-1/16	5/16	12-3/4	41	6	9-1/2	5/8	69
	C6-20E-36	36	45	8-15/16	12-15/16	38-7/8	5/16	13-7/16	47	6	9-1/2	5/8	78
	C6-20E-42	42	51	9-5/16	14-15/16	44-5/8	5/16	14-1/2	53	7-1/2	9-1/2	5/8	95
	C6-20E-48	48	57	9-5/16	16-15/16	50-3/8	5/16	15-3/16	59	7-1/2	9-1/2	5/8	105
	C6-20E-54	54	63	9-3/4	18-15/16	56-1/8	3/8	16-5/16	65-1/2	9	11	5/8	124
	C6-20E-60	60	69	9-3/4	20-15/16	61-7/8	3/8	17	71-1/2	9	11	5/8	135
35°	C6-35E-18	18	27	8-13/16	6-15/16	18-15/16	3/16	12-13/16	29	6	8	1/2	48
	C6-35E-24	24	33	8-15/16	8-15/16	24-1/4	5/16	14-1/8	35	6	9-1/2	5/8	59
	C6-35E-30	30	39	8-15/16	10-15/16	29-1/2	5/16	15-1/4	41	6	9-1/2	5/8	71
	C6-35E-36	36	45	8-15/16	12-15/16	34-13/16	5/16	16-7/16	47	6	9-1/2	5/8	80
	C6-35E-42	42	51	9-5/16	14-15/16	40-1/16	5/16	17-15/16	53	7-1/2	9-1/2	5/8	98
	C6-35E-48	48	57	9-5/16	16-15/16	45-3/8	5/16	19-1/8	59	7-1/2	9-1/2	5/8	109
	C6-35E-54	54	63	9-3/4	18-15/16	50-5/8	3/8	20-11/16	65-1/2	9	11	5/8	128
	C6-35E-60	60	69	9-3/4	20-15/16	55-15/16	3/8	21-13/16	71-1/2	9	11	5/8	139
45°	C6-45E-18	18	27	8-13/16	6-15/16	17-7/16	3/16	13-3/4	29	6	8	1/2	49
	C6-45E-24	24	33	8-15/16	8-15/16	22-1/4	5/16	15-5/16	35	6	9-1/2	5/8	60
	C6-45E-30	30	39	8-15/16	10-15/16	27-1/8	5/16	16-3/4	41	6	9-1/2	5/8	73
	C6-45E-36	36	45	8-15/16	12-15/16	31-15/16	5/16	18-3/16	47	6	9-1/2	5/8	82
	C6-45E-42	42	51	9-5/16	14-15/16	36-3/4	5/16	19-15/16	53	7-1/2	9-1/2	5/8	100
	C6-45E-48	48	57	9-5/16	16-15/16	41-5/8	5/16	21-3/8	59	7-1/2	9-1/2	5/8	111
	C6-45E-54	54	63	9-3/4	18-15/16	46-7/16	3/8	23-3/16	65-1/2	9	11	5/8	130
	C6-45E-60	60	69	9-3/4	20-15/16	51-1/4	3/8	24-5/8	71-1/2	9	11	5/8	141

Add "TTM", "DRY", "WET", "LOW" to the end of the part number to add application specific seals.

Add "MOX" to the end of the part number to replace steel cans with Moxie Rolls.

Recommended bolt pattern, see "Return & Flat Brackets Styles" section for minimum and maximum dimensions.

Individual bracket weights are listed on "Return & Flat Brackets Styles" section. Brackets sold separately.

# CEMA C IDLERS

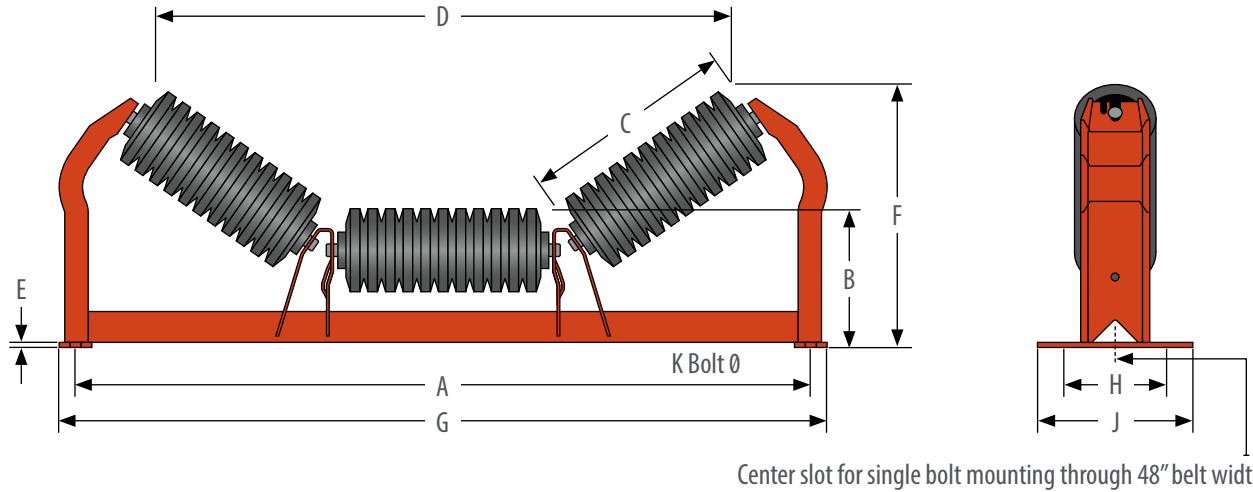

## RUBBER CUSHION IMPACT TROUGHING IDLERS: 4" DIAMETER

	PART NUMBER	BW	A	B	C	D	E	F	G	H	J	K	WT (#)
20°	C4-20EI-18	18	27	7-13/16	7-1/8	20-15/16	3/16	10-1/8	29	6	8	1/2	36
	C4-20EI-24	24	33	7-15/16	9-1/8	26-11/16	5/16	10-15/16	35	6	9-1/2	5/8	44
	C4-20EI-30	30	39	7-15/16	11-1/8	32-1/2	5/16	11-5/16	41	6	9-1/2	5/8	54
	C4-20EI-36	36	45	7-15/16	13-1/8	38-5/16	5/16	12-5/16	47	6	9-1/2	5/8	69
	C4-20EI-42	42	51	8-5/16	15-1/8	44-1/16	5/16	13-3/8	53	7-1/2	9-1/2	5/8	86
	C4-20EI-48	48	57	8-5/16	17-1/8	49-13/16	5/16	14-1/16	59	7-1/2	9-1/2	5/8	94
	C4-20EI-54	54	63	8-3/4	19-1/8	55-5/8	3/8	15-3/16	65-1/2	9	11	5/8	114
	C4-20EI-60	60	69	8-3/4	21-1/8	61-3/8	3/8	15-7/8	71-1/2	9	11	5/8	123
35°	C4-35EI-18	18	27	7-13/16	7-1/8	18-15/16	3/16	11-11/16	29	6	8	1/2	37
	C4-35EI-24	24	33	7-15/16	9-1/8	24-3/16	5/16	13	35	6	9-1/2	5/8	46
	C4-35EI-30	30	39	7-15/16	11-1/8	29-1/2	5/16	14-3/16	41	6	9-1/2	5/8	56
	C4-35EI-36	36	45	7-15/16	13-1/8	34-13/16	5/16	15-5/16	47	6	9-1/2	5/8	71
	C4-35EI-42	42	51	8-5/16	15-1/8	40-1/8	5/16	16-13/16	53	7-1/2	9-1/2	5/8	89
	C4-35EI-48	48	57	8-5/16	17-1/8	45-3/8	5/16	18	59	7-1/2	9-1/2	5/8	98
	C4-35EI-54	54	63	8-3/4	19-1/8	50-11/16	3/8	19-9/16	65-1/2	9	11	5/8	118
	C4-35EI-60	60	69	8-3/4	21-1/8	55-15/16	3/8	20-11/16	71-1/2	9	11	5/8	127
45°	C4-45EI-18	18	27	7-13/16	7-1/8	17-3/4	3/16	12-11/16	29	6	8	1/2	39
	C4-45EI-24	24	33	7-15/16	9-1/8	22-9/16	5/16	14-1/4	35	6	9-1/2	5/8	47
	C4-45EI-30	30	39	7-15/16	11-1/8	27-7/16	5/16	15-11/16	41	6	9-1/2	5/8	58
	C4-45EI-36	36	45	7-15/16	13-1/8	32-7/8	5/16	16-9/16	47	6	9-1/2	5/8	74
	C4-45EI-42	42	51	8-5/16	15-1/8	37-11/16	5/16	18-5/16	53	7-1/2	9-1/2	5/8	91
	C4-45EI-48	48	57	8-5/16	17-1/8	42-1/2	5/16	20-3/4	59	7-1/2	9-1/2	5/8	100
	C4-45EI-54	54	63	8-3/4	19-1/8	47-5/16	3/8	21-3/8	65-1/2	9	11	5/8	120
	C4-45EI-60	60	69	8-3/4	21-1/8	52-3/16	3/8	23	71-1/2	9	11	5/8	130

Add "TTM", "DRY", "WET", "LOW" to the end of the part number to add application specific seals.

For Bolt On End Stands add "BOE" example: C5-35EI-36BOE. / Belt Width (Reinforcing on 36" BW - 60" BW Impact Frame).

Recommended bolt pattern, see "Return & Flat Brackets Styles" section for minimum and maximum dimensions.

Individual bracket weights are listed on "Return & Flat Brackets Styles" section. Brackets sold separately.

# CEMA C IDLERS

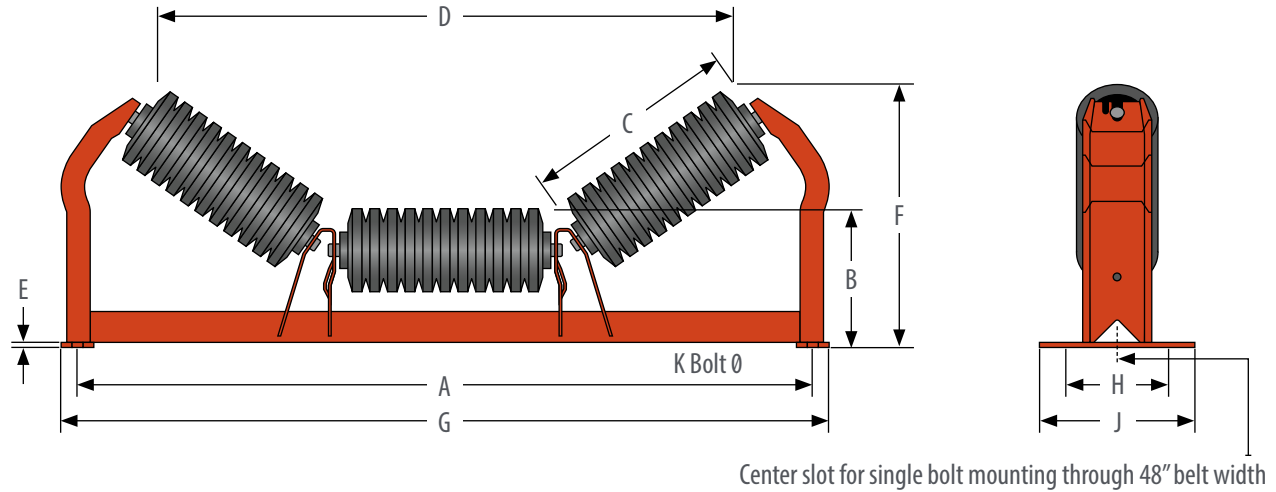

## RUBBER CUSHION IMPACT TROUGHING IDLERS: 5" DIAMETER

	PART NUMBER	BW	A	B	C	D	E	F	G	H	J	K	WT (#)
20°	CS-20EI-18	18	27	8-5/16	7-1/16	20-7/8	3/16	10-5/8	29	6	8	1/2	40
	CS-20EI-24	24	33	8-7/16	9-11/16	26-5/8	5/16	11-7/16	35	6	9-1/2	5/8	50
	CS-20EI-30	30	39	8-7/16	11-1/16	32-5/16	5/16	12-3/16	41	6	9-1/2	5/8	61
	CS-20EI-36	36	45	8-7/16	13-1/16	38-1/16	5/16	12-7/8	47	6	9-1/2	5/8	77
	CS-20EI-42	42	51	8-13/16	15-1/16	43-13/16	5/16	13-15/16	53	7-1/2	9-1/2	5/8	95
	CS-20EI-48	48	57	8-13/16	17-1/16	49-9/16	5/16	14-5/8	59	7-1/2	9-1/2	5/8	105
	CS-20EI-54	54	63	9-1/4	19-1/16	56-3/16	3/8	15-3/4	65-1/2	9	11	5/8	124
CS-20EI-60	60	69	9-1/4	21-1/16	61-15/16	3/8	16-7/16	71-1/2	9	11	5/8	136	
35°	CS-35EI-18	18	27	8-5/16	7-1/16	18-9/16	3/16	12-3/16	29	6	8	1/2	42
	CS-35EI-24	24	33	8-7/16	9-11/16	23-13/16	5/16	13-7/16	35	6	9-1/2	5/8	52
	CS-35EI-30	30	39	8-7/16	11-1/16	29-1/16	5/16	14-5/8	41	6	9-1/2	5/8	63
	CS-35EI-36	36	45	8-7/16	13-1/16	34-3/8	5/16	15-3/4	47	6	9-1/2	5/8	79
	CS-35EI-42	42	51	8-13/16	15-1/16	39-5/8	5/16	17-5/16	53	7-1/2	9-1/2	5/8	100
	CS-35EI-48	48	57	8-13/16	17-1/16	44-7/8	5/16	18-7/16	59	7-1/2	9-1/2	5/8	110
	CS-35EI-54	54	63	9-1/4	19-1/16	50-13/16	3/8	20-1/8	65-1/2	9	11	5/8	128
CS-35EI-60	60	69	9-1/4	21-1/16	56-1/8	3/8	21-1/4	71-1/2	9	11	5/8	140	
45°	CS-45EI-18	18	27	8-5/16	7-1/16	17-1/4	3/16	13-1/8	29	6	8	1/2	43
	CS-45EI-24	24	33	8-7/16	9-11/16	22-1/16	5/16	14-11/16	35	6	9-1/2	5/8	53
	CS-45EI-30	30	39	8-7/16	11-1/16	26-7/8	5/16	16-1/8	41	6	9-1/2	5/8	65
	CS-45EI-36	36	45	8-7/16	13-1/16	31-11/16	5/16	17-1/2	47	6	9-1/2	5/8	81
	CS-45EI-42	42	51	8-13/16	15-1/16	36-1/2	5/16	19-5/16	53	7-1/2	9-1/2	5/8	102
	CS-45EI-48	48	57	8-13/16	17-1/16	41-5/16	5/16	20-3/4	59	7-1/2	9-1/2	5/8	112
	CS-45EI-54	54	63	9-1/4	19-1/16	46-3/4	3/8	22-11/16	65-1/2	9	11	5/8	128
CS-45EI-60	60	69	9-1/4	21-1/16	51-9/16	3/8	24-1/16	71-1/2	9	11	5/8	143	

Add "TTM", "DRY", "WET", "LOW" to the end of the part number to add application specific seals.

For Bolt On End Stands add "BOE" example: CS-35EI-36BOE. / Belt Width (Reinforcing on 36" BW - 60" BW Impact Frame).

Recommended bolt pattern, see "Return & Flat Brackets Styles" section for minimum and maximum dimensions.

Individual bracket weights are listed on "Return & Flat Brackets Styles" section. Brackets sold separately.

# CEMA C IDLERS

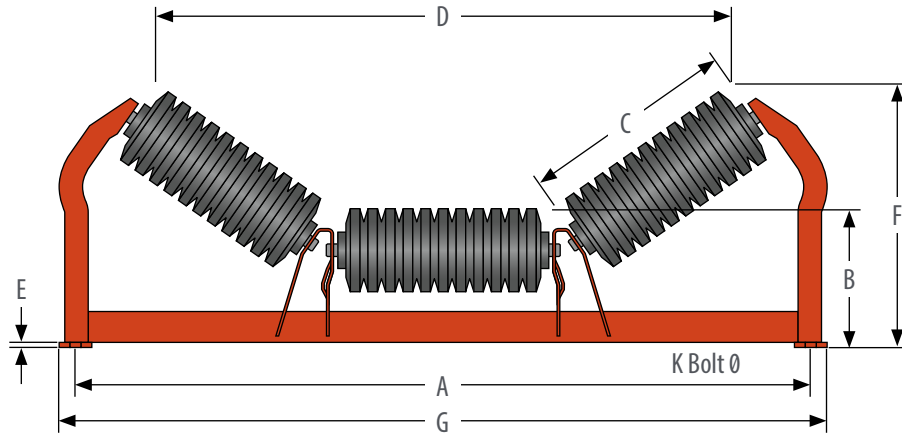

Center slot for single bolt mounting through 48" belt width

## RUBBER CUSHION IMPACT TROUGHING IDLERS: 6" DIAMETER

	PART NUMBER	BW	A	B	C	D	E	F	G	H	J	K	WT (#)
20°	C6-20EI-18	18	27	8-15/16	7-1/16	20-7/8	3/16	10-5/8	29	6	8	1/2	46
	C6-20EI-24	24	33	8-15/16	9-11/16	26-5/8	5/16	11-7/16	35	6	9-1/2	5/8	57
	C6-20EI-30	30	39	8-15/16	11-1/16	32-5/16	5/16	12-3/16	41	6	9-1/2	5/8	71
	C6-20EI-36	36	45	8-15/16	13-1/16	38-1/16	5/16	12-7/8	47	6	9-1/2	5/8	88
	C6-20EI-42	42	51	9-5/16	15-1/16	43-13/16	5/16	13-15/16	53	7-1/2	9-1/2	5/8	108
	C6-20EI-48	48	57	9-5/16	17-1/16	49-9/16	5/16	14-5/8	59	7-1/2	9-1/2	5/8	119
	C6-20EI-54	54	63	9-3/4	19	56-3/16	3/8	15-3/4	65-1/2	9	11	5/8	141
	C6-20EI-60	60	69	9-3/4	21	61-15/16	3/8	16-7/16	71-1/2	9	11	5/8	155
35°	C6-35EI-18	18	27	8-15/16	7-1/16	18-9/16	1/4	12-3/16	29	6	8	1/2	48
	C6-35EI-24	24	33	8-15/16	9-1/16	23-13/16	5/16	13-7/16	35	6	9-1/2	5/8	59
	C6-35EI-30	30	39	8-15/16	11-1/16	29-1/16	5/16	14-5/8	41	6	9-1/2	5/8	73
	C6-35EI-36	36	45	8-15/16	13-1/16	34-3/8	5/16	15-3/4	47	6	9-1/2	5/8	90
	C6-35EI-42	42	51	9-5/16	15-1/16	39-5/8	5/16	17-5/16	53	7-1/2	9-1/2	5/8	112
	C6-35EI-48	48	57	9-5/16	17-1/16	44-7/8	5/16	18-7/16	59	7-1/2	9-1/2	5/8	124
	C6-35EI-54	54	63	9-3/4	19	50-13/16	3/8	20-1/8	65-1/2	9	11	5/8	142
	C6-35EI-60	60	69	9-3/4	21	56-1/8	3/8	21-1/4	71-1/2	9	11	5/8	144
45°	C6-45EI-18	18	27	8-15/16	7	17-1/4	3/16	13-1/8	29	6	8	1/2	49
	C6-45EI-24	24	33	8-15/16	9	22-1/16	5/16	14-11/16	35	6	9-1/2	5/8	61
	C6-45EI-30	30	39	8-15/16	11	26-7/8	5/16	16-1/8	41	6	9-1/2	5/8	74
	C6-45EI-36	36	45	8-15/16	13	31-11/16	5/16	17-1/2	47	6	9-1/2	5/8	92
	C6-45EI-42	42	51	9-5/16	15	36-1/2	5/16	19-5/16	53	7-1/2	9-1/2	5/8	127
	C6-45EI-48	48	57	9-5/16	17	41-5/16	5/16	20-3/4	59	7-1/2	9-1/2	5/8	127
	C6-45EI-54	54	63	9-3/4	19	46-3/4	3/8	22-11/16	65-1/2	9	11	5/8	147
	C6-45EI-60	60	69	9-3/4	21	51-9/16	3/8	24-1/16	71-1/2	9	11	5/8	162

Add "TTM", "DRY", "WET", "LOW" to the end of the part number to add application specific seals.

For Bolt On End Stands add "BOE" example: C5-35EI-36BOE. / Belt Width (Reinforcing on 36" BW - 60" BW Impact Frame).

Recommended bolt pattern, see "Return & Flat Brackets Styles" section for minimum and maximum dimensions.

Individual bracket weights are listed on "Return & Flat Brackets Styles" section. Brackets sold separately.

# CEMA C IDLERS

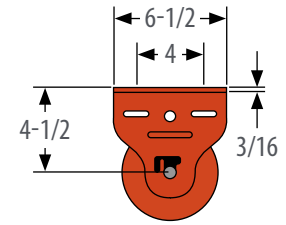
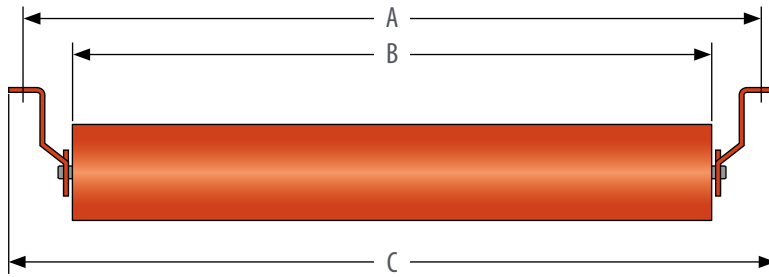

SLOTTED FOR 1/2" Ø BOLT

## RETURN IDLERS: 4", 5" AND 6" DIAMETER

PART NUMBER			BW	A	B	C	WT (#)		
4"	5"	6"					4"	5"	6"
C4-RET-16	C5-RET-16	C6-RET-16	16	25	19-1/4	26-7/16	16	21	27
C4-RET-18	C5-RET-18	C6-RET-18	18	27	21-1/4	28-7/16	17	23	30
C4-RET-20	C5-RET-20	C6-RET-20	20	29	23-1/4	30-7/16	18	24	31
C4-RET-24	C5-RET-24	C6-RET-24	24	33	27-1/4	34-7/16	21	27	37
C4-RET-30	C5-RET-30	C6-RET-30	30	39	33-1/4	40-7/16	24	32	43
C4-RET-36	C5-RET-36	C6-RET-36	36	45	39-1/4	46-7/16	27	37	50
C4-RET-42	C5-RET-42	C6-RET-42	42	51	45-1/4	52-7/16	31	41	57
C4-RET-48	C5-RET-48	C6-RET-48	48	57	51-1/4	58-7/16	32	46	63
C4-RET-54 ✓	C5-RET-54 ✓	C6-RET-54 ✓	54	63	57-1/4	64-7/16	42	54	74
C4-RET-60 ✓	C5-RET-60 ✓	C6-RET-60 ✓	60	69	63-1/4	70-7/16	45	60	81

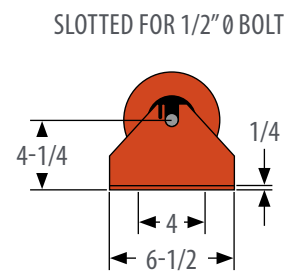
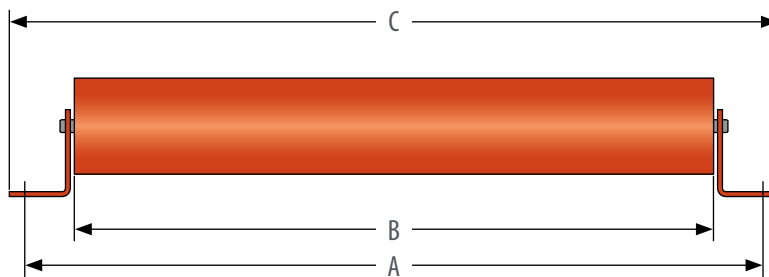

SLOTTED FOR 1/2" Ø BOLT

## FLAT IDLERS: 4", 5", AND 6" DIAMETER

PART NUMBER			BW	A	B	C	WT (#)		
4"	5"	6"					4"	5"	6"
C4-RET-16	C5-RET-16	C6-RET-16	16	25	19-1/4	26-15/16	19	23	-
C4-RET-18	C5-RET-18	C6-RET-18	18	27	21-1/4	28-15/16	20	25	32
C4-RET-20	C5-RET-20	C6-RET-20	20	29	23-1/4	30-15/16	21	27	34
C4-RET-24	C5-RET-24	C6-RET-24	24	33	27-1/4	34-15/16	23	30	39
C4-RET-30	C5-RET-30	C6-RET-30	30	39	33-1/4	40-15/16	26	34	46
C4-RET-36	C5-RET-36	C6-RET-36	36	45	39-1/4	46-15/16	30	39	52
C4-RET-42	C5-RET-42	C6-RET-42	42	51	45-1/4	52-15/16	33	44	59
C4-RET-48	C5-RET-48	C6-RET-48	48	57	51-1/4	58-15/16	36	48	66
C4-RET-54 ✓	C5-RET-54 ✓	C6-RET-54 ✓	54	63	57-1/4	64-15/16	44	57	76
C4-RET-60 ✓	C5-RET-60 ✓	C6-RET-60 ✓	60	69	63-1/4	70-15/16	48	63	84

Add "TTM", "DRY", "WET", "LOW" to the end of the part number to add application specific seals.

Individual bracket weights are listed on "Return & Flat Brackets Styles" section. Brackets sold separately.

✓ Meets CEMA D specs. Add "MOX" to the end of the part number to replace steel cans with Moxie Rolls.



# CEMA C IDLERS

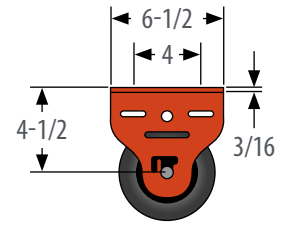
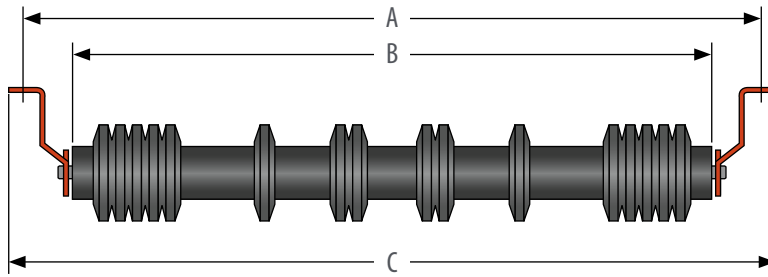

SLOTTED FOR 1/2" Ø BOLT

## RUBBER CUSHION RETURN IDLERS: 4", 5", AND 6" DIAMETER

PART NUMBER			BW	A	B	C	WT (#)		
4"	5"	6"					4"	5"	6"
C4-RETI-18	C5-RETI-18	C6-RETI-18	18	27	21-5/16	28-7/16	20	23	26
C4-RETI-20	C5-RETI-20	C6-RETI-20	20	29	23-5/16	30-7/16	22	25	29
C4-RETI-24	C5-RETI-24	C6-RETI-24	24	33	27-5/16	34-7/16	25	28	32
C4-RETI-30	C5-RETI-30	C6-RETI-30	30	39	33-5/16	40-7/16	29	32	37
C4-RETI-36	C5-RETI-36	C6-RETI-36	36	45	39-5/16	46-7/16	34	37	43
C4-RETI-42	C5-RETI-42	C6-RETI-42	42	51	45-5/16	52-7/16	38	42	47
C4-RETI-48	C5-RETI-48	C6-RETI-48	48	57	51-5/16	58-7/16	42	46	51
C4-RETI-54 ✓	C5-RETI-54 ✓	C6-RETI-54 ✓	54	63	57-5/16	64-7/16	50	54	60
C4-RETI-60 ✓	C5-RETI-60 ✓	C6-RETI-60 ✓	60	69	63-5/16	70-7/16	55	60	66

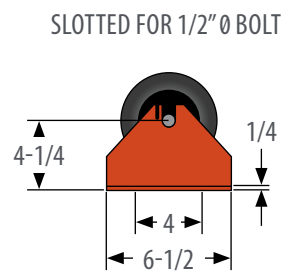
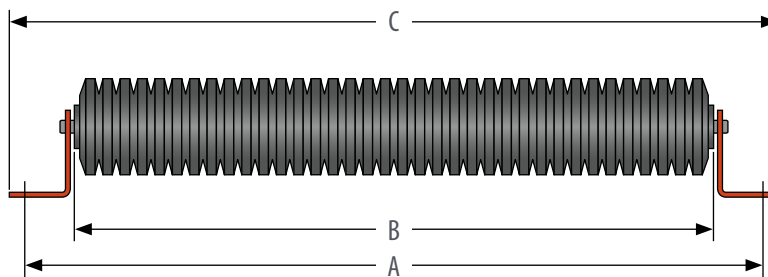

SLOTTED FOR 1/2" Ø BOLT

## RUBBER CUSHION FLAT IDLERS: 4", 5", AND 6" DIAMETER

PART NUMBER			BW	A	B	C	WT (#)		
4"	5"	6"					4"	5"	6"
C4-FLTI-18	C5-FLTI-18	C6-FLTI-18	18	27	21-5/16	28-15/16	25	30	36
C4-FLTI-20	C5-FLTI-20	C6-FLTI-20	20	29	23-5/16	30-15/16	26	31	38
C4-FLTI-24	C5-FLTI-24	C6-FLTI-24	24	33	27-5/16	34-15/16	30	36	44
C4-FLTI-30	C5-FLTI-30	C6-FLTI-30	30	39	33-5/16	40-15/16	35	43	53
C4-FLTI-36	C5-FLTI-36	C6-FLTI-36	36	45	39-5/16	46-15/16	40	49	62
C4-FLTI-42	C5-FLTI-42	C6-FLTI-42	42	51	45-5/16	52-15/16	45	56	70
C4-FLTI-48	C5-FLTI-48	C6-FLTI-48	48	57	51-5/16	58-15/16	51	63	79
C4-FLTI-54 ✓	C5-FLTI-54 ✓	C6-FLTI-54 ✓	54	63	57-5/16	64-15/16	60	73	91
C4-FLTI-60 ✓	C5-FLTI-60 ✓	C6-FLTI-60 ✓	60	69	63-5/16	70-15/16	65	80	100

Add "TTM", "DRY", "WET", "LOW" to the end of the part number to add application specific seals.

Individual bracket weights are listed on "Return & Flat Brackets Styles" section. Brackets sold separately.

✓ Meets CEMA D specs. Add "MOX" to the end of the part number to replace steel cans with Moxie Rolls.

# CEMA C IDLERS

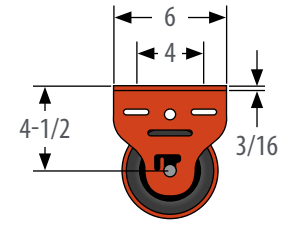
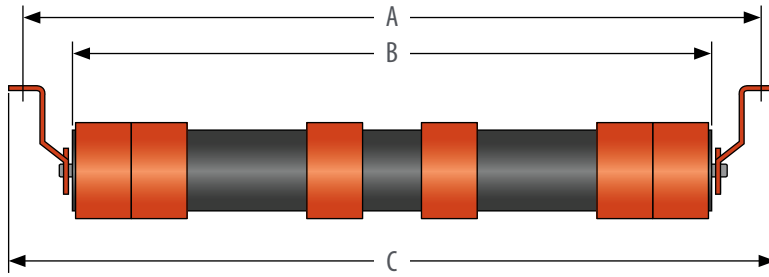

SLOTTED FOR 1/2" Ø BOLT

## URATHON® RETURN ROLLS: 5" AND 6" DIAMETER

PART NUMBERS		BW	A	B	C	WT (#)	
5"	6"					5"	6"
CS-RETU-18	C6-RETU-18	18	27	21-1/4	28-7/16	22	28
CS-RETU-24	C6-RETU-24	24	33	27-1/4	34-7/16	25	33
CS-RETU-30	C6-RETU-30	30	39	33-1/4	40-7/16	30	39
CS-RETU-36	C6-RETU-36	36	45	39-1/4	46-7/16	34	45
CS-RETU-42	C6-RETU-42	42	51	45-1/4	52-7/16	38	50
CS-RETU-48	C6-RETU-48	48	57	51-1/4	58-7/16	42	56
CS-RETU-54	C6-RETU-54	54	63	57-1/4	64-7/16	50	66
CS-RETU-60	C6-RETU-60	60	69	63-1/4	70-7/16	55	72

Add "TTM", "DRY", "WET", "LOW" to the end of the part number to add application specific seals.

Spiral Urathon is only available in 6" diameter. To order Spiral Urathon version add "SP" after "RETU" in the part number.

Individual bracket weights are listed on "Return & Flat Brackets Styles" section. Brackets sold separately.

# CEMA C IDLERS

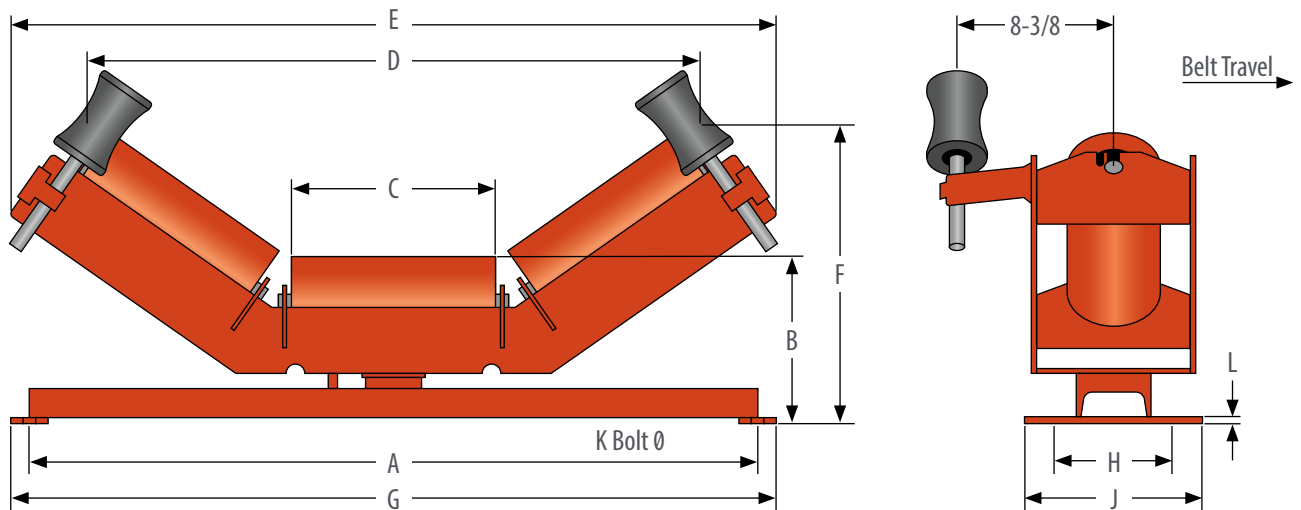

## SELF-ALIGNING TROUGHING IDLERS: 4" DIAMETER

	PART NUMBER	BW	A	B	C	D	E	F	G	H	J	K	L	WT(#)
20°	C4-20EA-18	18	27	8-3/8	7	23-3/16	31	11-1/16	29	6	8	1/2	3/16	80
	C4-20EA-24	24	33	8-1/2	9	28-15/16	36-3/4	11-7/8	35	6	9-1/2	1/2	5/16	91
	C4-20EA-30	30	39	8-1/2	11	34-11/16	42-9/16	12-9/16	41	6	9-1/2	1/2	5/16	100
	C4-20EA-36	36	45	8-1/2	13	40-7/16	48-5/16	13-1/4	47	6	9-1/2	1/2	5/16	109
	C4-20EA-42	42	51	9	15	46	54-3/16	14-7/16	53	7-1/2	9-1/2	5/8	5/16	123
	C4-20EA-48	48	57	9	17	51-3/4	60	15-1/8	59	7-1/2	9-1/2	5/8	5/16	133
	C4-20EA-54	54	63	9-1/16	19	57-1/2	65-3/4	15-7/8	65-1/2	9	11	5/8	3/8	145
C4-20EA-60	60	69	9-1/16	21	63-5/16	72-1/2	16-9/16	71-1/2	9	11	5/8	3/8	155	
35°	C4-35EA-18	18	27	8-3/8	7	20-1/4	30-3/8	12-3/4	29	6	8	1/2	3/16	81
	C4-35EA-24	24	33	8-1/2	9	25-9/16	35-11/16	14	35	6	9-1/2	1/2	5/16	91
	C4-35EA-30	30	39	8-1/2	11	30-13/16	40-15/16	15-1/8	41	6	9-1/2	1/2	5/16	101
	C4-35EA-36	36	45	8-1/2	13	36-1/16	46-1/4	16-5/16	47	6	9-1/2	1/2	5/16	110
	C4-35EA-42	42	51	9	15	41-1/16	51-3/16	17-15/16	53	7-1/2	9-1/2	5/8	5/16	123
	C4-35EA-48	48	57	9	17	46-5/16	56-1/2	19-1/8	59	7-1/2	9-1/2	5/8	5/16	133
	C4-35EA-54	54	63	9-1/16	19	51-5/8	61-3/4	20-5/16	65-1/2	9	11	5/8	3/8	145
C4-35EA-60	60	69	9-1/16	21	56-7/8	67	21-7/16	71-1/2	9	11	5/8	3/8	156	
45°	C4-45EA-18	18	27	8-3/8	7	19-7/16	30-11/16	13-5/8	29	6	8	1/2	3/16	82
	C4-45EA-24	24	33	8-1/2	9	24-1/4	35-1/2	15-1/8	35	6	9-1/2	1/2	5/16	93
	C4-45EA-30	30	39	8-1/2	11	29-1/16	40-5/16	16-9/16	41	6	9-1/2	1/2	5/16	102
	C4-45EA-36	36	45	8-1/2	13	33-7/8	45-3/16	18	47	6	9-1/2	1/2	5/16	111
	C4-45EA-42	42	51	9	15	38-5/16	50-5/16	20-1/4	53	7-1/2	9-1/2	5/8	5/16	137
	C4-45EA-48	48	57	9	17	43-1/8	55-1/8	21-5/16	59	7-1/2	9-1/2	5/8	5/16	135
	C4-45EA-54	54	63	9-1/16	19	47-15/16	59-15/16	22-13/16	65-1/2	9	11	5/8	3/8	147
C4-45EA-60	60	69	9-1/16	21	52-13/16	64-3/4	24-3/16	71-1/2	9	11	5/8	3/8	157	

Add "TTM", "DRY", "WET", "LOW" to the end of the part number to add application specific seals.

Also available in bi-directional shoe-activating. Designated by "BA".

Individual bracket weights are listed on "Return & Flat Brackets Styles" section. Brackets sold separately.

# CEMA C IDLERS

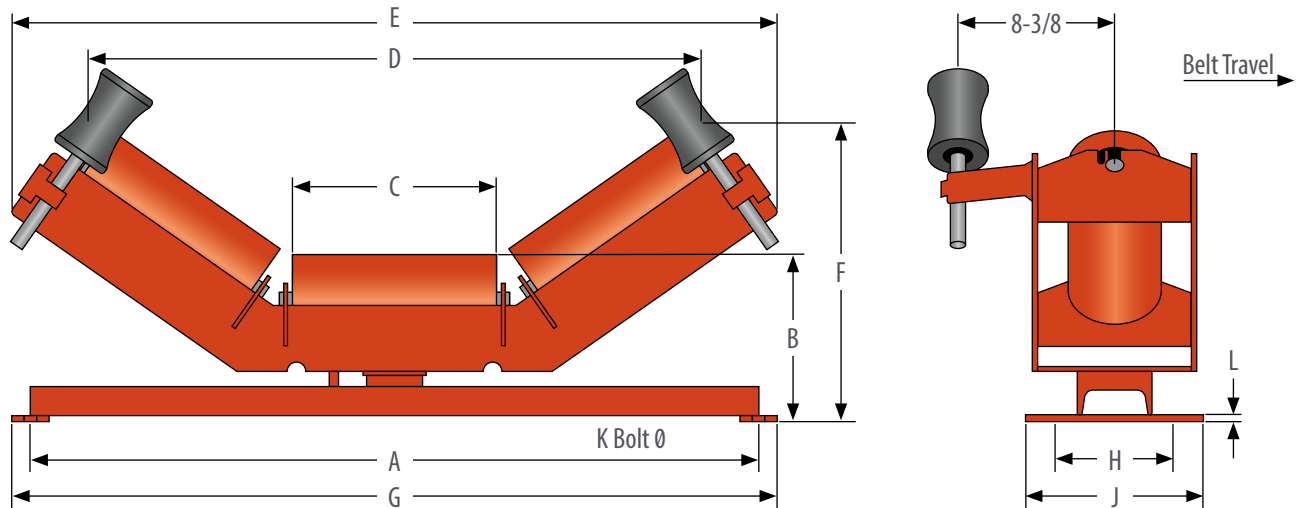

## SELF-ALIGNING TROUGHING IDLERS: 5" DIAMETER

	PART NUMBER	BW	A	B	C	D	E	F	G	H	J	K	L	WT(#)
20°	C5-20EA-18	18	27	8-7/8	7-1/16	22-7/8	31	11-9/16	29	6	8	1/2	3/16	86
	C5-20EA-24	24	33	9	9-1/16	28-5/8	36-3/4	12-3/8	35	6	9-1/2	1/2	5/16	98
	C5-20EA-30	30	39	9	11-1/16	34-3/8	42-9/16	13-1/16	41	6	9-1/2	1/2	5/16	109
	C5-20EA-36	36	45	9	13-1/16	40-1/8	48-5/16	13-3/4	47	6	9-1/2	1/2	5/16	120
	C5-20EA-42	42	51	9-1/2	15-1/16	45-3/4	54-3/16	14-15/16	53	7-1/2	9-1/2	5/8	5/16	134
	C5-20EA-48	48	57	9-1/2	17-1/16	51-1/2	60	15-5/8	59	7-1/2	9-1/2	5/8	5/16	146
	C5-20EA-54	54	63	9-9/16	19-1/16	57-1/4	65-3/4	16-3/8	65-1/2	9	11	5/8	3/8	160
	C5-20EA-60	60	69	9-9/16	21-1/16	63	71-1/2	17-1/16	71-1/2	9	11	5/8	3/8	171
35°	C5-35EA-18	18	27	8-7/8	7-1/16	19-3/4	30-3/8	13-1/8	29	6	8	1/2	3/16	87
	C5-35EA-24	24	33	9	9-1/16	25	35-11/16	14-7/16	35	6	9-1/2	1/2	5/16	98
	C5-35EA-30	30	39	9	11-1/16	30-5/16	40-15/16	15-09/16	41	6	9-1/2	1/2	5/16	109
	C5-35EA-36	36	45	9	13-1/16	35-9/16	46-1/4	16-11/16	47	6	9-1/2	1/2	5/16	120
	C5-35EA-42	42	51	9-1/2	15-1/16	40-1/2	51-3/16	18-3/8	53	7-1/2	9-1/2	5/8	5/16	135
	C5-35EA-48	48	57	9-1/2	17-1/16	45-13/16	56-1/2	19-1/2	59	7-1/2	9-1/2	5/8	5/16	146
	C5-35EA-54	54	63	9-9/16	19-1/16	51-1/16	61-3/4	20-11/16	65-1/2	9	11	5/8	3/8	160
	C5-35EA-60	60	69	9-9/16	21-1/16	56-3/8	67	21-7/8	71-1/2	9	11	5/8	3/8	171
45°	C5-45EA-18	18	27	8-7/8	7-1/16	18-3/4	30-11/16	14	29	6	8	1/2	3/16	88
	C5-45EA-24	24	33	9	9-1/16	23-9/16	35-1/2	15-1/2	35	6	9-1/2	1/2	5/16	100
	C5-45EA-30	30	39	9	11-1/16	28-7/16	40-5/16	16-15/16	41	6	9-1/2	1/2	5/16	111
	C5-45EA-36	36	45	9	13-1/16	33-1/4	45-1/4	18-3/16	47	6	9-1/2	1/2	5/16	122
	C5-45EA-42	42	51	9-1/2	15-1/16	37-5/8	50-5/16	20-1/4	53	7-1/2	9-1/2	5/8	5/16	137
	C5-45EA-48	48	57	9-1/2	17-1/16	42-1/2	55-1/8	21-11/16	59	7-1/2	9-1/2	5/8	5/16	148
	C5-45EA-54	54	63	9-9/16	19-1/16	47-5/16	59-15/16	23-3/16	65-1/2	9	11	5/8	3/8	162
	C5-45EA-60	60	69	9-9/16	21-1/16	52-1/8	64-3/4	24-9/16	71-1/2	9	11	5/8	3/8	171

Add "TTM", "DRY", "WET", "LOW" to the end of the part number to add application specific seals.

Also available in bi-directional shoe-activating. Designated by "BA".

Individual bracket weights are listed on "Return & Flat Brackets Styles" section. Brackets sold separately.

# CEMA C IDLERS

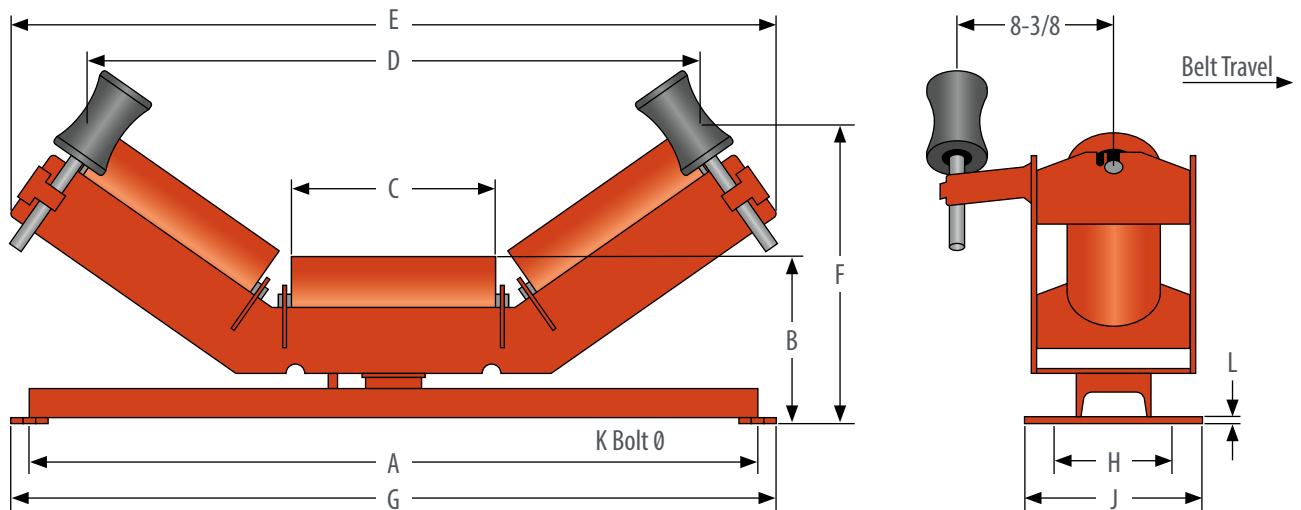

## SELF-ALIGNING TROUGHING IDLERS: 6" DIAMETER

	PART NUMBER	BW	A	B	C	D	E	F	G	H	J	K	L	WT(#)
20°	C6-20EA-18	18	27	9-3/8	7	22-9/16	31	12	29	6	8	1/2	3/16	94
	C6-20EA-24	24	33	9-1/2	9	28-5/16	36-3/4	12-13/16	35	6	9-1/2	1/2	5/16	108
	C6-20EA-30	30	39	9-1/2	11	34-1/16	42-9/16	13-1/2	41	6	9-1/2	1/2	5/16	121
	C6-20EA-36	36	45	9-1/2	13	39-13/16	48-5/16	14-3/16	47	6	9-1/2	1/2	5/16	134
	C6-20EA-42	42	51	10	15	45-3/8	54-3/16	15-3/8	53	7-1/2	9-1/2	5/8	5/16	150
	C6-20EA-48	48	57	10	17	51-1/8	60	16-1/16	59	7-1/2	9-1/2	5/8	5/16	163
	C6-20EA-54	54	63	10-1/16	19	56-15/16	65-3/4	16-13/16	65-1/2	9	11	5/8	3/8	179
	C6-20EA-60	60	69	10-1/16	21	62-11/16	71-1/2	17-1/2	71-1/2	9	11	5/8	3/8	192
35°	C6-35EA-18	18	27	9-3/8	7	19-3/16	30-3/8	13-9/16	29	6	8	1/2	3/16	94
	C6-35EA-24	24	33	9-1/2	9	24-1/2	35-11/16	14-13/16	35	6	9-1/2	1/2	5/16	109
	C6-35EA-30	30	39	9-1/2	11	29-3/4	40-15/16	15-15/16	41	6	9-1/2	1/2	5/16	122
	C6-35EA-36	36	45	9-1/2	13	35-1/16	46-1/4	17-1/8	47	6	9-1/2	1/2	5/16	134
	C6-35EA-42	42	51	10	15	40	51-3/16	18-3/4	53	7-1/2	9-1/2	5/8	5/16	151
	C6-35EA-48	48	57	10	17	45-1/4	56-1/2	19-7/8	59	7-1/2	9-1/2	5/8	5/16	164
	C6-35EA-54	54	63	10-1/16	19	50-9/16	61-3/4	21-1/8	65-1/2	9	11	5/8	3/8	180
	C6-35EA-60	60	69	10-1/16	21	55-13/16	67	22-1/4	71-1/2	9	11	5/8	3/8	193
45°	C6-45EA-18	18	27	9-3/8	7	18-1/8	30-11/16	14-5/16	29	6	8	1/2	3/16	95
	C6-45EA-24	24	33	9-1/2	9	22-15/16	35-1/2	15-13/16	35	6	9-1/2	1/2	5/16	110
	C6-45EA-30	30	39	9-1/2	11	27-3/4	40-5/16	17-1/4	41	6	9-1/2	1/2	5/16	123
	C6-45EA-36	36	45	9-1/2	13	32-9/16	45-1/4	18-5/8	47	6	9-1/2	1/2	5/16	136
	C6-45EA-42	42	51	10	15	37	50-5/16	20-9/16	53	7-1/2	9-1/2	5/8	5/16	152
	C6-45EA-48	48	57	10	17	41-13/16	55-1/8	22	59	7-1/2	9-1/2	5/8	5/16	166
	C6-45EA-54	54	63	10-1/16	19	46-11/16	59-15/16	23-7/16	65-1/2	9	11	5/8	3/8	181
	C6-45EA-60	60	69	10-1/16	21	51-1/2	64-3/4	24-7/8	71-1/2	9	11	5/8	3/8	193

Add "TTM", "DRY", "WET", "LOW" to the end of the part number to add application specific seals.

Also available in bi-directional shoe-activating. Designated by "BA".

Individual bracket weights are listed on "Return & Flat Brackets Styles" section. Brackets sold separately.

# CEMA C IDLERS

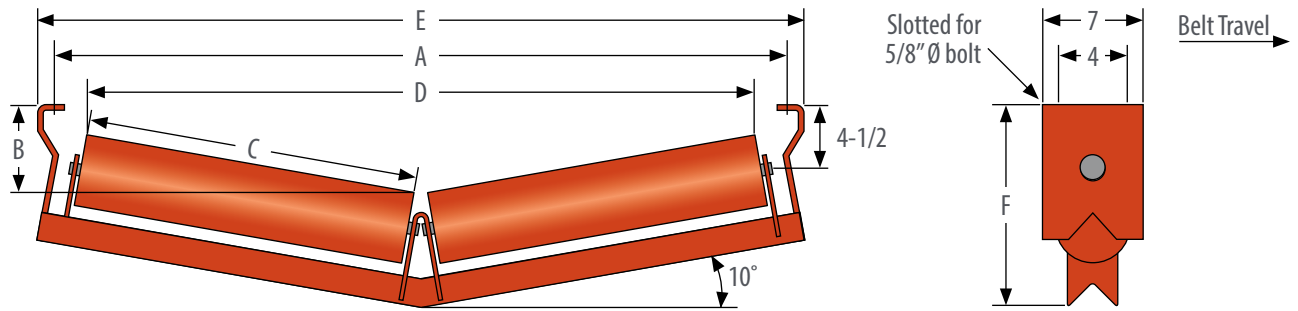

For wider base use next size larger belt width. Also available in 15°.

## V-RETURN IDLERS: 4", 5", AND 6" DIAMETER

PART NUMBER			BW	A	B			C	D			E	F	WT (#)		
4"	5"	6"			4"	5"	6"		4"	5"	6"			4"	5"	6"
C4-10RETV-24	C5-10RETV-24	C6-10RETV-24	24	33	4-15/16	4-7/16	3-15/16	14-3/8	28-7/8	28-13/16	28-5/8	35-1/8	12-3/8	42	49	58
C4-10RETV-30	C5-10RETV-30	C6-10RETV-30	30	39	5-1/2	5	4-1/2	17	34-3/16	34-1/16	33-7/8	41-1/8	12-7/8	46	55	67
C4-10RETV-36	C5-10RETV-36	C6-10RETV-36	36	45	6	5-1/2	5	20-3/8	40-15/16	40-7/8	40-11/16	47-1/8	13-3/8	52	62	74
C4-10RETV-42	C5-10RETV-42	C6-10RETV-42	42	51	6-1/2	6-1/16	5-9/16	23-3/8	46-5/8	46-1/2	46-3/8	53-1/8	14	56	68	82
C4-10RETV-48	C5-10RETV-48	C6-10RETV-48	48	57	7-1/16	6-9/16	6-1/16	26-1/2	52-7/8	52-3/4	52-9/16	59-1/8	14-1/2	61	74	92
C4-10RETV-54	C5-10RETV-54	C6-10RETV-54	54	63	7-9/16	7-1/8	6-5/8	29-1/4	58-3/16	58-1/8	57-15/16	65-1/8	15-3/8	82	96	114
C4-10RETV-60	C5-10RETV-60	C6-10RETV-60	60	69	8-1/8	7-5/8	7-1/8	32-1/2	64-11/16	64-9/16	64-3/8	71-1/8	15-7/8	89	105	127

Add "TTM", "DRY", "WET", "LOW" to the end of the part number to add application specific seals.

Individual bracket weights are listed on "Return & Flat Brackets Styles" section. Brackets sold separately.

# CEMA C IDLERS

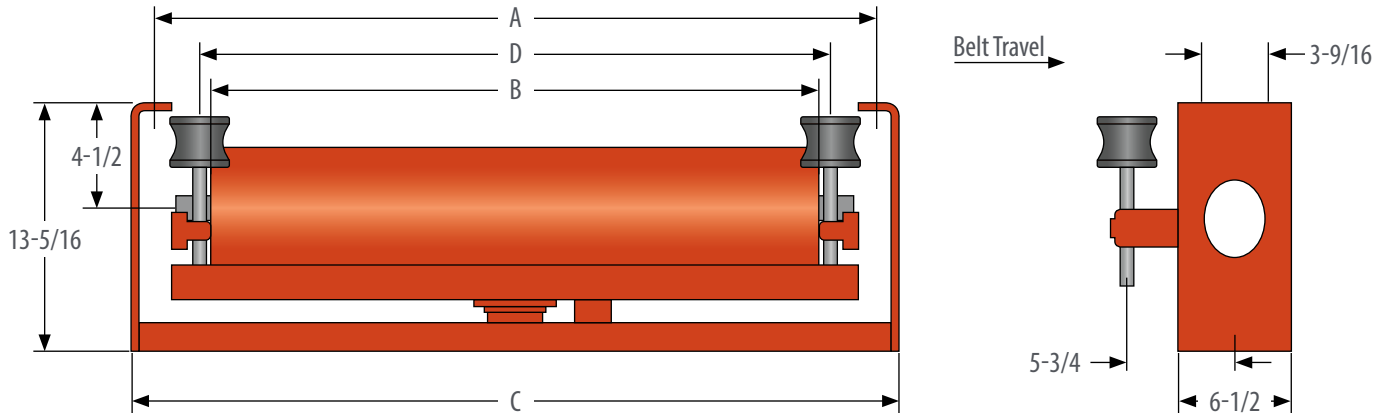

## SELF-ALIGNING RETURN IDLER: 4", 5" AND 6" DIAMETER

PART NUMBER			BW	A	B	C	D	WT (#)		
4"	5"	6"						4"	5"	6"
C4-RETA-18	C5-RETA-18	C6-RETA-18	18	27	21-1/4	29-1/2	25-5/8	63	69	76
C4-RETA-24	C5-RETA-24	C6-RETA-24	24	33	27-1/4	35-1/2	31-5/8	71	78	87
C4-RETA-30	C5-RETA-30	C6-RETA-30	30	39	33-1/4	41-1/2	37-11/16	82	90	101
C4-RETA-36	C5-RETA-36	C6-RETA-36	36	45	39-1/4	47-1/2	43-5/8	90	99	113
C4-RETA-42	C5-RETA-42	C6-RETA-42	42	51	45-1/4	53-1/2	49-5/8	106	117	132
C4-RETA-48	C5-RETA-48	C6-RETA-48	48	57	51-1/4	59-1/2	55-5/8	116	128	145
C4-RETA-54 ✓	C5-RETA-54 ✓	C6-RETA-54 ✓	54	63	57-1/4	65-1/2	61-5/8	129	142	162
C4-RETA-60 ✓	C5-RETA-60 ✓	C6-RETA-60 ✓	60	69	63-1/4	71-1/2	67-5/8	139	153	175

Add "TTM", "DRY", "WET", "LOW" to the end of the part number to add application specific seals.

Also available in bi-directional shoe-activated option. Designated by "RETBA". ✓ Meets CEMA D specifications.

Self-aligning return idlers are also available in lagged roller. Designed by "RETAI".

Individual bracket weights are listed on "Return & Flat Brackets Styles" section. Brackets sold separately.

Bigfoot bolting pattern and lagged roller option available.

# CEMA C IDLERS

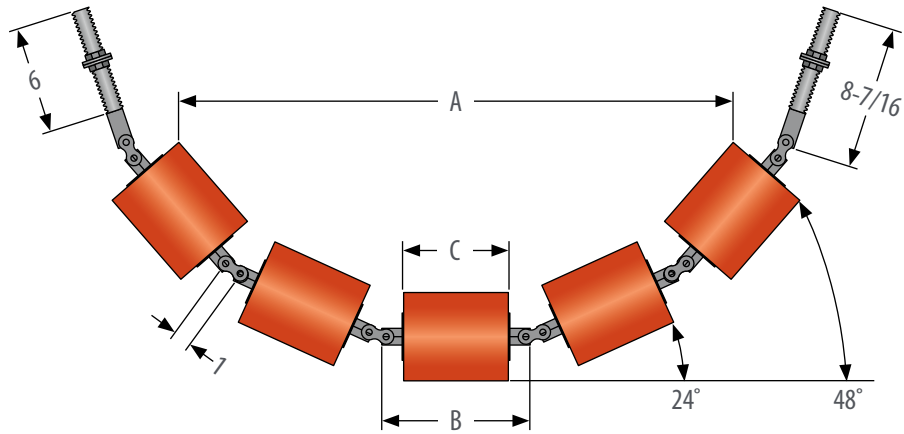

## GARLAND IDLERS: 4", 5", AND 6" DIAMETER

	PART NUMBER	BW	# OF ROLLS	A	B	C	WT (#)
4" Diameter	43-3400-16	16	3	21-5/16	8-1/16	6-1/16	15
	43-3400-18	18	3	21-5/16	8-1/16	6-1/16	17
	43-3400-24	24	3	25-7/8	9-11/16	7-11/16	20
	43-3400-30	30	5	32-5/8	8-1/16	6-1/16	28
	43-3400-36	36	5	36-13/16	9-1/16	7	31
	43-3400-42	42	5	45-1/8	11-1/16	9	36
	43-3400-48	48	5	53-7/16	13-1/16	11	42
	43-3400-54	54	5	61-13/16	15-1/16	13	47
	43-3400-60	60	5	70-1/8	17-1/16	15	53
	5" Diameter	43-3500-16	16	5	20-15/16	8-1/16	6-1/16
43-3500-18		18	5	20-15/16	8-1/16	6-1/16	22
43-3500-24		24	5	25-1/2	9-11/16	7-11/16	26
43-3500-30		30	5	32-3/16	8-1/16	6-1/16	37
43-3500-36		36	5	36-3/8	9-1/16	7	41
43-3500-42		42	5	44-11/16	11-1/16	9	48
43-3500-48		48	5	53	13-1/16	11	56
43-3500-54		54	5	61-3/8	15-1/16	13	64
43-3500-60		60	5	69-11/16	17-1/16	15	72
6" Diameter		43-3600-16	16	3	20-9/16	8-1/16	6-1/16
	43-3600-18	18	3	20-9/16	8-1/16	6-1/16	22
	43-3600-24	24	3	25-3/16	9-11/16	7-11/16	26
	43-3600-30	30	5	31-9/16	8-1/16	6-1/16	37
	43-3600-36	36	5	35-11/16	9-1/16	7	41
	43-3600-42	42	5	44	11-1/16	9	48
	43-3600-48	48	5	52-3/8	13-1/16	11	56
	43-3600-54	54	5	60-11/16	15-1/16	13	64
	43-3600-60	60	5	69	17-1/16	15	72



# CEMA C IDLERS

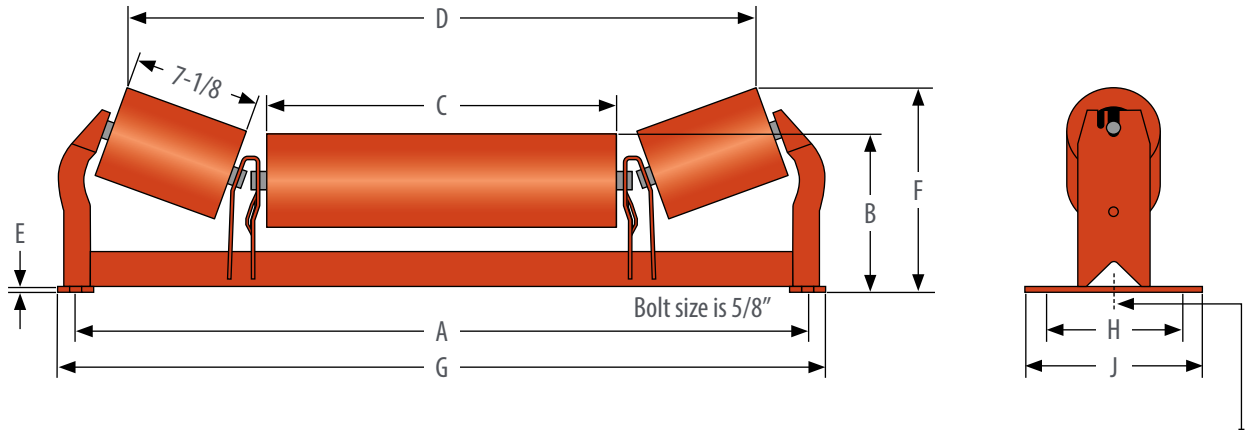

Center slot for single bolt mounting through 48" belt width

## FEEDER / PICKING TROUGHING IDLERS: 4", 5", AND 6" DIAMETER

	PART NUMBER	BW	A	B	C	D	E	F	G	H	J	WT (#)
4" Diameter	C4-20P-24	24	33	7-15/16	13	28-1/8	5/16	10-3/8	35	6	9-1/2	39
	C4-20P-30	30	39	7-15/16	19	34-1/8	5/16	10-7/16	41	6	9-1/2	47
	C4-20P-36	36	45	7-15/16	25	40	5/16	10-7/16	47	6	9-1/2	52
	C4-20P-42	42	51	8-5/16	30-3/4	46-1/16	5/16	10-7/16	53	7-1/2	9-1/2	66
	C4-20P-48	48	57	8-5/16	36-3/4	52-1/4	5/16	10-7/16	51-3/4	7-1/2	9-1/2	72
	C4-20P-54	54	63	8-3/4	42-7/16	57-15/16	3/8	11-3/16	65-1/2	9	11	87
5" Diameter	C4-20P-60	60	69	8-3/4	48-7/16	63-15/16	3/8	11-3/16	71-1/2	9	11	94
	C5-20P-24	24	33	8-7/16	13-1/16	27-13/16	5/16	10-7/8	35	6	9-1/2	47
	C5-20P-30	30	39	8-7/16	19-1/16	33-7/8	5/16	10-7/8	41	6	9-1/2	56
	C5-20P-36	36	45	8-7/16	25-1/16	39-7/8	5/16	10-7/8	47	6	9-1/2	63
	C5-20P-42	42	51	8-13/16	30-13/16	46	5/16	10-15/16	53	7-1/2	9-1/2	77
	C5-20P-48	48	57	8-13/16	36-13/16	52	5/16	11-3/16	59	7-1/2	9-1/2	85
6" Diameter	C5-20P-54	54	63	9-1/4	42-1/2	57-5/8	3/8	11-11/16	65-1/2	9	11	101
	C5-20P-60	60	69	9-1/4	48-1/2	63-5/8	3/8	11-11/16	71-1/2	9	11	109
	C6-20P-24	24	33	8-15/16	13	27-1/2	5/16	11-3/8	35	6	9-1/2	56
	C6-20P-30	30	39	8-15/16	19	33-1/2	5/16	11-3/8	41	6	9-1/2	67
	C6-20P-36	36	45	8-15/16	25	39-1/2	5/16	11-3/8	47	6	9-1/2	76
	C6-20P-42	42	51	9-5/16	30-13/16	45-3/4	5/16	11-7/16	53	7-1/2	9-1/2	91
6" Diameter	C6-20P-48	48	57	9-5/16	36-13/16	51-3/4	5/16	11-3/8	59	7-1/2	9-1/2	101
	C6-20P-54	54	63	9-3/4	42-9/16	57-5/16	3/8	12-1/8	65-1/2	9	11	118
	C6-20P-60	60	69	9-3/4	48-9/16	63-5/16	3/8	12-1/8	71-1/2	9	11	128

Add "TTM", "DRY", "WET", "LOW" to the end of the part number to add application specific seals.

Belt Width (Reinforcing on 36" BW - 60" BW Impact Frame only, use "PI" for part number).

Recommended bolt pattern, see "Return & Flat Brackets Styles" section for minimum and maximum dimensions.

Use "PCI" for part number when requiring Impact Rolls only in the center.

# CEMA C IDLERS

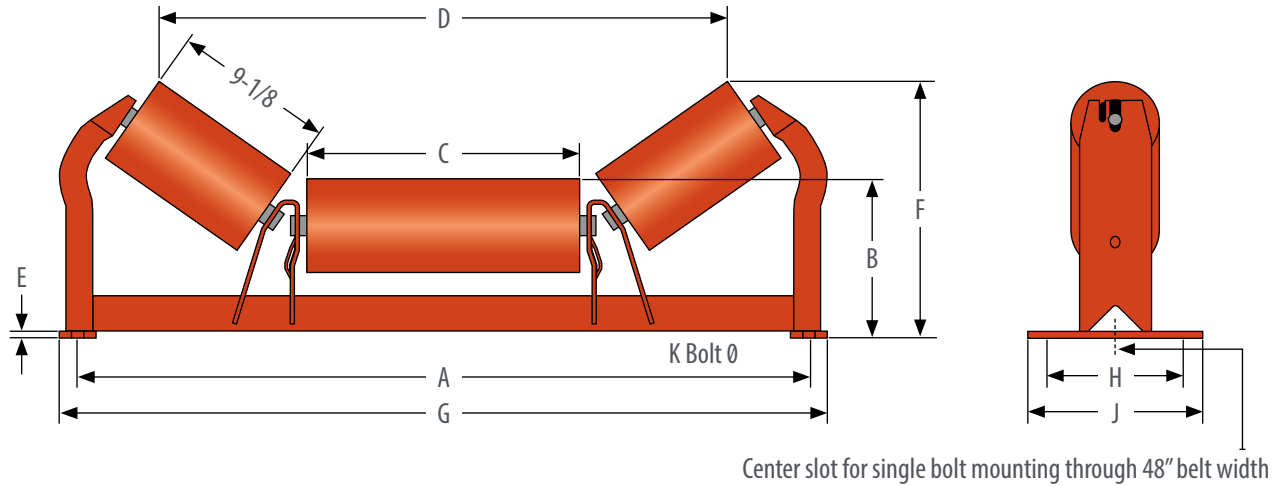

## TROUGHING IDLERS (UNEQUAL LENGTH ROLLS): 4" DIAMETER

	PART NUMBER	BW	A	B	C	D	E	F	G	H	J	K	WT (#)
20°	C4-20U-30	30	39	7-15/16	15	33-7/8	5/16	11-1/8	41	6	9-1/2	5/8	47
	C4-20U-36	36	45	7-15/16	21	36-7/8	5/16	11-1/8	47	6	9-1/2	5/8	53
	C4-20U-42	42	51	8-5/16	26-1/2	46	5/16	11-1/8	53	7-1/2	9-1/2	5/8	66
	C4-20U-48	48	57	8-5/16	32-7/16	52	5/16	11-1/8	59	7-1/2	9-1/2	5/8	72
	C4-20U-54	54	63	8-3/4	38	58-1/16	3/8	11-1/4	65-1/2	9	11	5/8	81
	C4-20U-60	60	69	8-3/4	44	64-1/16	3/8	11-1/4	71-1/2	9	11	5/8	94
35°	C4-20U-30	30	39	7-15/16	15-1/16	31-1/4	5/16	13-1/4	41	6	9-1/2	5/8	49
	C4-20U-36	36	45	7-15/16	21	37-1/4	5/16	13-1/4	47	6	9-1/2	5/8	55
	C4-20U-42	42	51	8-5/16	26-1/4	41-5/8	5/16	14-11/16	53	7-1/2	9-1/2	5/8	69
	C4-20U-48	48	57	8-5/16	32-7/16	49-3/8	5/16	13-5/16	59	7-1/2	9-1/2	5/8	74
	C4-20U-54	54	63	8-3/4	38	55-3/8	3/8	13-7/16	65-1/2	9	11	5/8	89
	C4-20U-60	60	69	8-3/4	44	61-3/8	3/8	13-7/16	71-1/2	9	11	5/8	96
45°	C4-20U-30	30	39	7-15/16	15	29-9/16	5/16	14-5/8	41	6	9-1/2	5/8	51
	C4-20U-36	36	45	7-15/16	21	35-9/16	5/16	14-5/8	47	6	9-1/2	5/8	56
	C4-20U-42	42	51	8-5/16	26-1/4	41-5/8	5/16	14-11/16	53	7-1/2	9-1/2	5/8	70
	C4-20U-48	48	57	8-5/16	32-1/4	47-5/8	5/16	14-11/16	59	7-1/2	9-1/2	5/8	76
	C4-20U-54	54	63	8-3/4	37-9/16	53-5/8	3/8	14-13/16	65-1/2	9	11	5/8	90
	C4-20U-60	60	69	8-3/4	43-9/16	59-5/8	3/8	14-13/16	71-1/2	9	11	5/8	97

Add "TTM", "DRY", "WET", "LOW" to the end of the part number to add application specific seals.

Belt Width (Reinforcing on 36" BW - 60" BW Impact Frame only).

Recommended bolt pattern, see "Return & Flat Brackets Styles" section for minimum and maximum dimensions.

Also available in rubber cushioned roller. Designated by "UI".

# CEMA C IDLERS

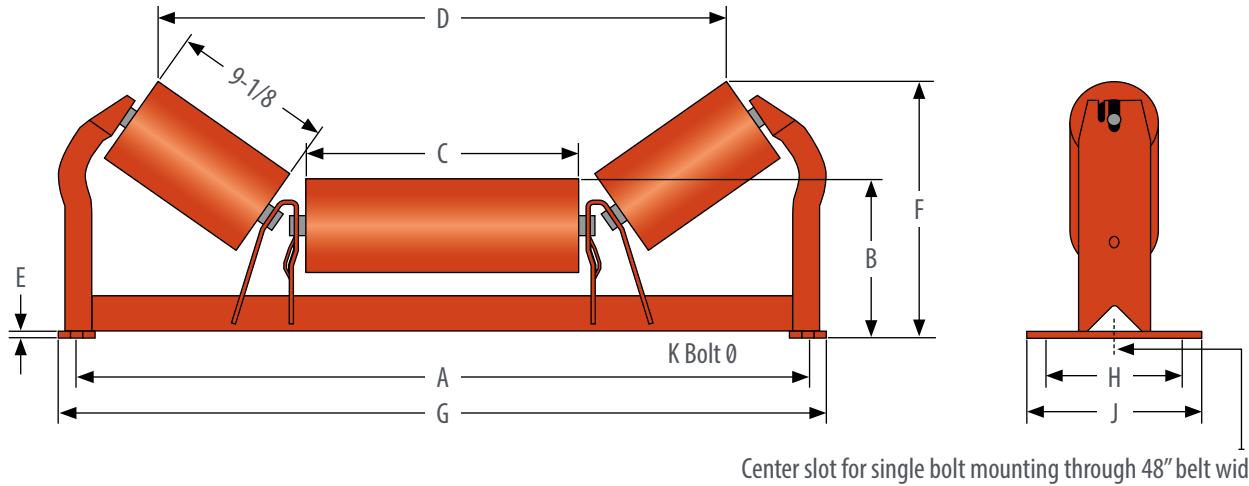

## TROUGHING IDLERS (UNEQUAL LENGTH ROLLS): 5" DIAMETER

	PART NUMBER	BW	A	B	C	D	E	F	G	H	J	K	WT (#)
20°	CS-20U-30	30	39	8-7/16	15-1/16	33-5/8	5/16	11-9/16	41	6	9-1/2	5/8	57
	CS-20U-36	36	45	8-7/16	21-1/16	39-5/8	5/16	11-9/16	47	6	9-1/2	5/8	63
	CS-20U-42	42	51	8-13/16	26-9/16	45-3/4	5/16	11-5/8	53	7-1/2	9-1/2	5/8	78
	CS-20U-48	48	57	8-13/16	32-9/16	51-3/4	5/16	11-5/8	59	7-1/2	9-1/2	5/8	85
	CS-20U-54	54	63	9-1/4	38-1/16	57-7/8	3/8	11-3/4	65-1/2	9	11	5/8	101
	CS-20U-60	60	69	9-1/4	44-1/16	63-7/8	3/8	11-3/4	71-1/2	9	11	5/8	109
35°	CS-35U-30	30	39	8-7/16	15-1/16	30-3/4	5/16	13-11/16	41	6	9-1/2	5/8	58
	CS-35U-36	36	45	8-7/16	21-1/16	36-3/4	5/16	13-11/16	47	6	9-1/2	5/8	65
	CS-35U-42	42	51	8-13/16	26-9/16	42-7/8	5/16	13-3/4	53	7-1/2	9-1/2	5/8	80
	CS-35U-48	48	57	8-13/16	32-9/16	48-7/8	5/16	13-3/4	59	7-1/2	9-1/2	5/8	87
	CS-35U-54	54	63	9-1/4	38-1/16	54-15/16	3/8	13-15/16	65-1/2	9	11	5/8	103
	CS-35U-60	60	69	9-1/4	44-1/16	60-15/16	3/8	13-15/16	71-1/2	9	11	5/8	111
45°	CS-45U-30	30	39	8-7/16	15-1/16	28-7/8	5/16	15	41	6	9-1/2	5/8	60
	CS-45U-36	36	45	8-7/16	21-1/16	34-7/8	5/16	15	47	6	9-1/2	5/8	66
	CS-45U-42	42	51	8-13/16	26-5/16	41	5/16	15-1/8	53	7-1/2	9-1/2	5/8	81
	CS-45U-48	48	57	8-13/16	32-5/16	47	5/16	15-1/8	59	7-1/2	9-1/2	5/8	89
	CS-45U-54	54	63	9-1/4	37-5/8	53-1/16	3/8	15-1/4	65-1/2	9	11	5/8	104
	CS-45U-60	60	69	9-1/4	43-5/8	59-1/16	3/8	15-1/4	71-1/2	9	11	5/8	112

Add "TTM", "DRY", "WET", "LOW" to the end of the part number to add application specific seals.

Belt Width (Reinforcing on 36" BW - 60" BW Impact Frame only).

Recommended bolt pattern, see "Return & Flat Brackets Styles" section for minimum and maximum dimensions.

Also available in rubber cushioned roller. Designated by "UI".

# CEMA C IDLERS

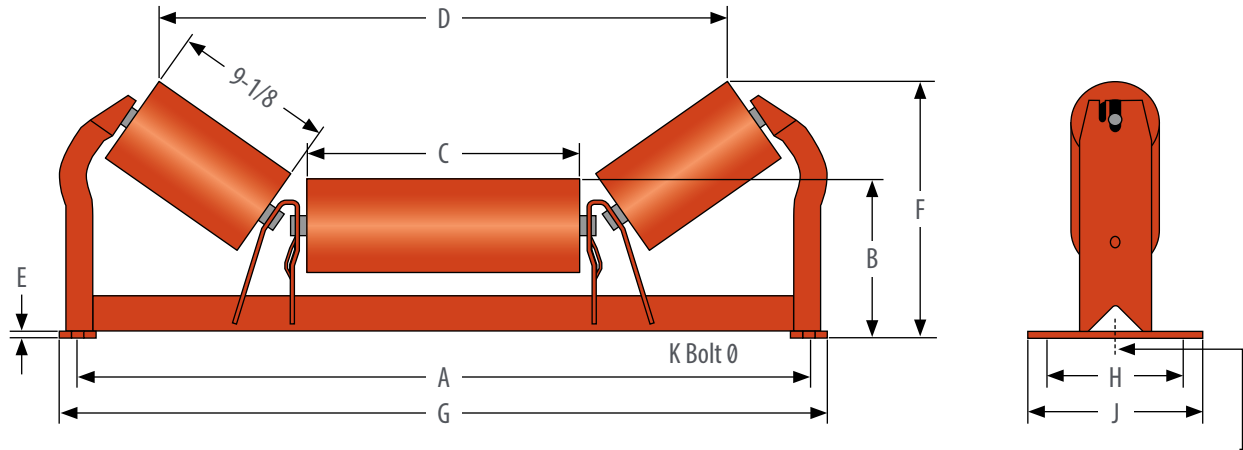

Center slot for single bolt mounting through 48" belt width

## TROUGHING IDLERS (UNEQUAL LENGTH ROLLS): 6" DIAMETER

	PART NUMBER	BW	A	B	C	D	E	F	G	H	J	K	WT (#)
20°	C6-20U-30	30	39	8-15/16	15	33-1/4	5/16	12-1/16	41	6	9-1/2	5/8	68
	C6-20U-36	36	45	8-15/16	21	39-1/4	5/16	12-1/16	47	6	9-1/2	5/8	77
	C6-20U-42	42	51	9-5/16	26-9/16	45-7/16	5/16	12-11/16	53	7-1/2	9-1/2	5/8	93
	C6-20U-48	48	57	9-5/16	32-9/16	51-7/16	5/16	12-1/8	59	7-1/2	9-1/2	5/8	102
	C6-20U-54	54	63	9-3/4	38-1/16	57-9/16	3/8	12-3/16	65-1/2	9	11	5/8	119
	C6-20U-60	60	69	9-3/4	44-1/16	63-9/16	3/8	12-3/16	71-1/2	9	11	5/8	129
35°	C6-35U-30	30	39	8-15/16	15	30-3/16	5/16	14-1/16	41	6	9-1/2	5/8	70
	C6-35U-36	36	45	8-15/16	12	36-3/16	5/16	14-1/16	47	6	9-1/2	5/8	79
	C6-35U-42	42	51	9-5/16	26-9/16	42-3/8	5/16	14-3/16	53	7-1/2	9-1/2	5/8	94
	C6-35U-48	48	57	9-5/16	32-9/16	48-3/8	5/16	14-3/16	59	7-1/2	9-1/2	5/8	104
	C6-35U-54	54	63	9-3/4	38-1/16	54-1/2	3/8	14-5/16	65-1/2	9	11	5/8	121
	C6-35U-60	60	69	9-3/4	44-1/16	60-1/2	3/8	14-5/16	71-1/2	9	11	5/8	131
45°	C6-45U-30	30	39	8-15/16	15	28-1/4	5/16	15-5/16	41	6	9-1/2	5/8	72
	C6-45U-36	36	45	8-15/16	21	34-1/4	5/16	15-5/16	47	6	9-1/2	5/8	80
	C6-45U-42	42	51	9-5/16	26-5/16	40-3/8	5/16	15-7/16	53	7-1/2	9-1/2	5/8	96
	C6-45U-48	48	57	9-5/16	32-5/16	46-3/8	5/16	15-7/16	59	7-1/2	9-1/2	5/8	105
	C6-45U-54	54	63	9-3/4	37-5/8	52-1/2	3/8	15-9/16	65-1/2	9	11	5/8	122
	C6-45U-60	60	69	9-3/4	43-5/8	58-1/2	3/8	15-9/16	71-1/2	9	11	5/8	132

Add "TTM", "DRY", "WET", "LOW" to the end of the part number to add application specific seals.

Belt Width (Reinforcing on 36" BW - 60" BW Impact Frame only).

Recommended bolt pattern, see "Return & Flat Brackets Styles" section for minimum and maximum dimensions.

Also available in rubber cushioned roller. Designated by "UI".

# CEMA C IDLERS

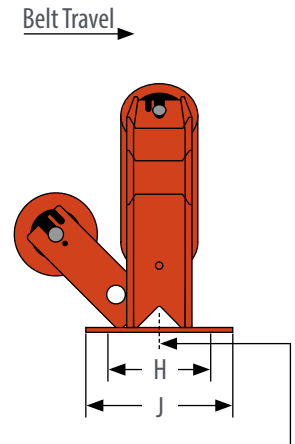
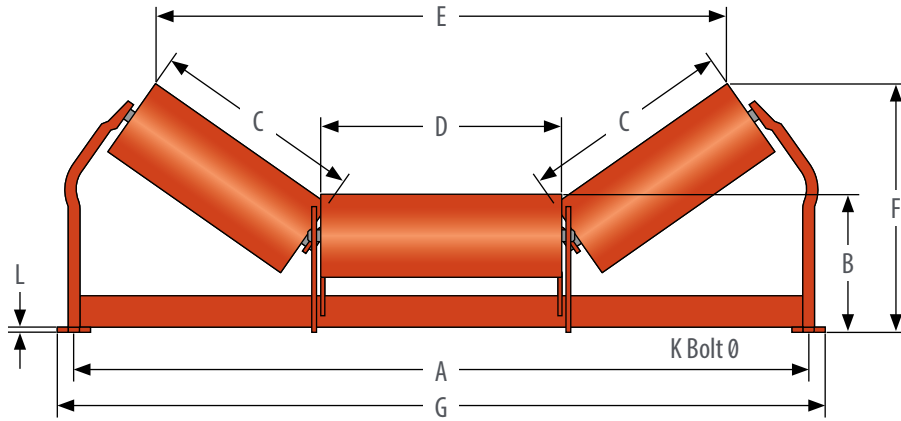

Center slot for single bolt mounting through 48" belt width

## OFFSET CENTER ROLL IDLER: 4" DIAMETER

	PART NUMBER	BW	A	B	C	D	E	F	G	H	J	K	L	WT (#)
20°	C4-20G0-24	24	33	7-7/8	9	11	27-15/16	11-1/8	35	6	9-1/2	5/8	5/16	43
	C4-20G0-30	30	39	7-7/8	11	13	33-11/16	11-13/16	41	6	9-1/2	5/8	5/16	52
	C4-20G0-36	36	45	7-7/8	13	15	39-7/16	12-1/2	47	6	9-1/2	5/8	5/16	57
	C4-20G0-42	42	51	8-5/16	15	17	45-3/16	13-9/16	53	7-1/2	9-1/2	5/8	5/16	72
	C4-20G0-48	48	57	8-5/16	17	19	51	14-1/4	59	7-1/2	9-1/2	5/8	5/16	78
	C4-20G0-54	54	63	8-11/16	19	21	56-3/4	15-5/16	65-1/2	9	11	5/8	3/8	94
35°	C4-20G0-60	60	69	8-11/16	21	23-5/16	62-1/2	16	71-1/2	9	11	5/8	3/8	101
	C4-35G0-24	24	33	7-15/16	9	11	25-5/16	13-5/16	35	6	9-1/2	5/8	5/16	45
	C4-35G0-30	30	39	7-15/16	11	13	30-9/16	14-7/16	41	6	9-1/2	5/8	5/16	54
	C4-35G0-36	36	45	7-15/16	13	15	35-7/8	15-5/8	47	6	9-1/2	5/8	5/16	60
	C4-35G0-42	42	51	8	15	17	41-1/8	17-1/8	53	7-1/2	9-1/2	5/8	5/16	75
	C4-35G0-48	48	57	8	17	19	46-3/8	18-5/16	59	7-1/2	9-1/2	5/8	5/16	82
45°	C4-35G0-54	54	63	8-7/16	19	21	51-11/16	19-7/8	65-1/2	9	11	5/8	3/8	97
	C4-35G0-60	60	69	8-7/16	21	23-5/16	56-15/16	21	71-1/2	9	11	5/8	3/8	105
	C4-45G0-24	24	33	8-11/16	9	11	23-1/2	14-5/8	35	6	9-1/2	5/8	5/16	46
	C4-45G0-30	30	39	8-11/16	11	13	28-7/16	16-1/16	41	6	9-1/2	5/8	5/16	56
	C4-45G0-36	36	45	9-1/16	13	15	33-1/4	17-1/2	47	6	9-1/2	5/8	5/16	62
	C4-45G0-42	42	51	9-1/16	15	17	38-1/16	19-5/16	53	7-1/2	9-1/2	5/8	5/16	77
45°	C4-45G0-48	48	57	9-1/16	17	19	42-15/16	20-11/16	59	7-1/2	9-1/2	5/8	5/16	84
	C4-45G0-54	54	63	9-1/2	19	21	47-3/4	22-1/2	65-1/2	9	11	5/8	3/8	100
	C4-45G0-60	60	69	9-1/2	21	23-5/16	52-9/16	23-15/16	71-1/2	9	11	5/8	3/8	108

Add "TTM", "DRY", "WET", "LOW" to the end of the part number to add application specific seals.

Recommended bolt pattern, see "Return & Flat Brackets Styles" section for minimum and maximum dimensions.

# CEMA C IDLERS

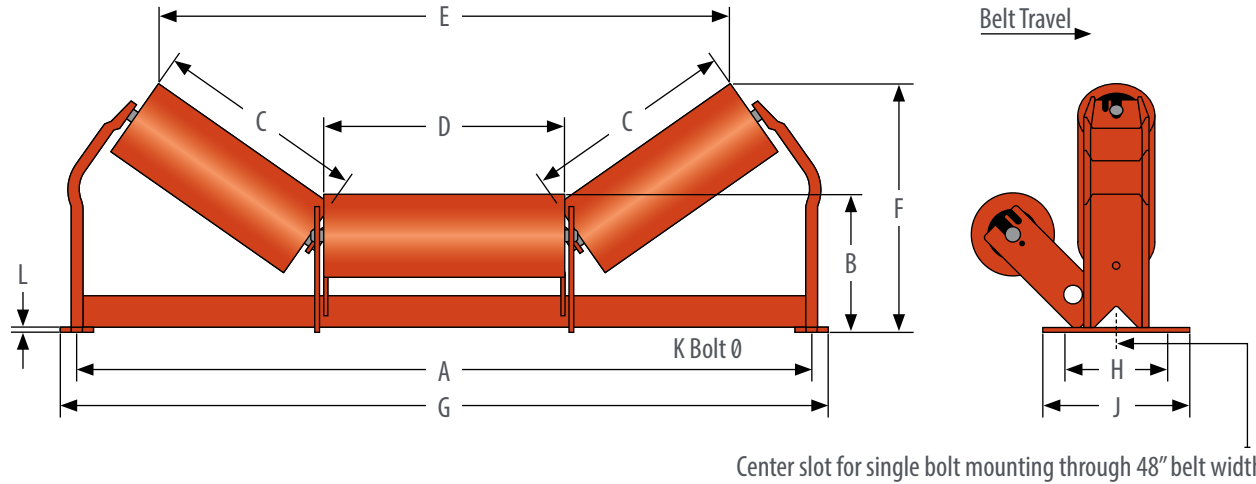

## OFFSET CENTER ROLL IDLER: 5" DIAMETER

	PART NUMBER	BW	A	B	C	D	E	F	G	H	J	K	L	WT (#)
20°	C5-20G0-18	18	27	8-1/4	7-1/16	9-1/16	21-7/8	10-3/4	29	6	8	5/8	5/16	43
	C5-20G0-24	24	33	8-3/8	9-1/16	11-1/16	27-5/16	11-9/16	35	6	9-1/2	5/8	5/16	51
	C5-20G0-30	30	39	8-3/8	11-1/16	13-1/16	33-7/16	12-5/16	41	6	9-1/2	5/8	5/16	61
	C5-20G0-36	36	45	8-3/8	13-1/16	15-1/16	39-3/16	12-15/16	47	6	9-1/2	5/8	5/16	68
	C5-20G0-42	42	51	8-13/16	15-1/16	17-1/16	44-15/16	14-1/16	53	7-1/2	9-1/2	5/8	5/16	83
	C5-20G0-48	48	57	8-13/16	17-1/16	19-1/16	50-11/16	14-3/4	59	7-1/2	9-1/2	5/8	5/16	92
	C5-20G0-54	54	63	9-3/16	19-1/16	21-1/16	56-7/16	15-13/16	65-1/2	9	11	5/8	3/8	108
C5-20G0-60	60	69	9-3/16	21-1/16	23-3/8	62-3/16	16-1/2	71-1/2	9	11	5/8	3/8	117	
35°	C5-35G0-18	18	27	8-7/8	7-1/16	9-1/16	19-1/2	12-7/16	29	6	8	1/2	3/16	45
	C5-35G0-24	24	33	9	9-1/16	11-1/16	24-3/4	13-11/16	35	6	9-1/2	5/8	5/16	53
	C5-35G0-30	30	39	9	11-1/16	13-1/16	30-1/16	14-7/8	41	6	9-1/2	5/8	5/16	63
	C5-35G0-36	36	45	9-9/16	13-1/16	15-1/16	35-5/16	16	47	6	9-1/2	5/8	5/16	71
	C5-35G0-42	42	51	9-1/16	15-1/16	17-1/16	40-5/8	17-9/16	53	7-1/2	9-1/2	5/8	5/16	86
	C5-35G0-48	48	57	9-1/16	17-1/16	19-1/16	45-7/8	18-11/16	59	7-1/2	9-1/2	5/8	5/16	97
	C5-35G0-54	54	63	9-7/16	19-1/16	21-1/16	51-1/8	20-1/4	65-1/2	9	11	5/8	3/8	112
C5-35G0-60	60	69	9-7/16	21-1/16	23-3/8	56-7/16	21-7/16	71-1/2	9	11	5/8	3/8	115	
45°	C5-45G0-18	18	27	9-1/16	7-1/16	9-1/16	18-1/16	13-1/2	29	6	9-1/2	5/8	5/16	46
	C5-45G0-24	24	33	9-3/16	9-1/16	11-1/16	22-7/8	15	35	6	9-1/2	5/8	5/16	54
	C5-45G0-30	30	39	9-3/16	11-1/16	13-1/16	27-3/4	16-7/16	41	6	9-1/2	5/8	5/16	65
	C5-45G0-36	36	45	9-3/16	13-1/16	15-1/16	32-9/16	17-7/8	47	6	9-1/2	5/8	5/16	72
	C5-45G0-42	42	51	9-9/16	15-1/16	17-1/16	37-7/16	19-5/8	53	7-1/2	9-1/2	5/8	5/16	89
	C5-45G0-48	48	57	9-9/16	17-1/16	19-1/16	42-1/4	21-1/16	59	7-1/2	9-1/2	5/8	5/16	97
	C5-45G0-54	54	63	10	19-1/16	21-1/16	47-1/16	22-7/8	65-1/2	9	11	5/8	3/8	115
C5-45G0-60	60	69	10	21-1/16	23-3/8	51-7/8	24-5/16	71-1/2	9	11	5/8	3/8	124	

Add "TTM", "DRY", "WET", "LOW" to the end of the part number to add application specific seals.

Recommended bolt pattern, see "Return & Flat Brackets Styles" section for minimum and maximum dimensions.

# CEMA C IDLERS

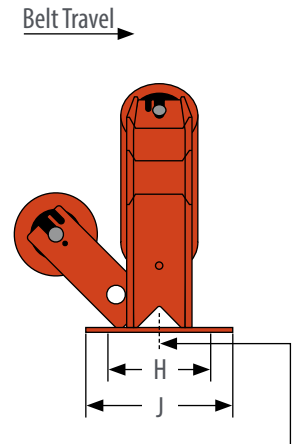
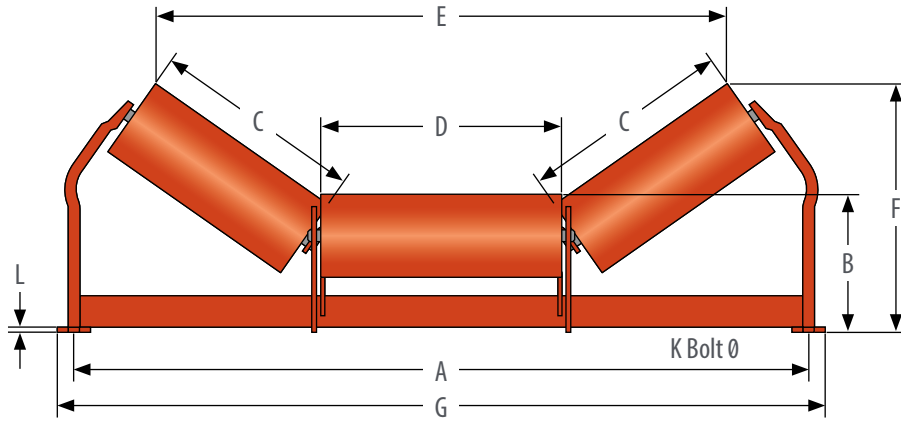

Center slot for single bolt mounting through 48" belt width

## OFFSET CENTER ROLL IDLER: 6" DIAMETER

	PART NUMBER	BW	A	B	C	D	E	F	G	H	J	K	L	WT (#)
20°	C6-20G0-18	18	27	8-3/4	7	9	21-9/16	11-1/4	29	6	8	5/8	5/16	52
	C6-20G0-24	24	33	8-7/8	9	11	27-5/16	12-1/16	35	6	9-1/2	5/8	5/16	62
	C6-20G0-30	30	39	8-7/8	11	13	33-1/16	12-3/4	41	6	9-1/2	5/8	5/16	73
	C6-20G0-36	36	45	8-7/8	13	15	38-7/8	13-7/16	47	6	9-1/2	5/8	5/16	83
	C6-20G0-42	42	51	9-5/16	15	17	44-5/8	14-1/2	53	7-1/2	9-1/2	5/8	5/16	100
	C6-20G0-48	48	57	9-5/16	17	19	50-3/8	15-3/16	59	7-1/2	9-1/2	5/8	5/16	110
	C6-20G0-54	54	63	9-11/16	19	21	56-1/8	16-5/16	65-1/2	9	11	5/8	3/8	129
C6-20G0-60	60	69	9-11/16	21	23-3/8	61-7/8	17	71-1/2	9	11	5/8	3/8	139	
35°	C6-35G0-18	18	27	8-13/16	7	9	18-15/16	12-13/16	29	6	8	1/2	3/16	53
	C6-35G0-24	24	33	8-15/16	9	11	24-1/4	14-1/8	35	6	9-1/2	5/8	5/16	64
	C6-35G0-30	30	39	8-15/16	11	13	29-1/2	15-1/4	41	6	9-1/2	5/8	5/16	76
	C6-35G0-36	36	45	8-15/16	13	15	34-13/16	16-7/16	47	6	9-1/2	5/8	5/16	85
	C6-35G0-42	42	51	9	15	17	40-1/16	17-15/16	53	7-1/2	9-1/2	5/8	5/16	103
	C6-35G0-48	48	57	9	17	19	45-3/8	19-1/8	59	7-1/2	9-1/2	5/8	5/16	113
	C6-35G0-54	54	63	9-7/16	19	21	50-5/8	20-11/16	65-1/2	9	11	5/8	3/8	132
C6-35G0-60	60	69	9-7/16	21	23-3/8	55-7/8	21-13/16	71-1/2	9	11	5/8	3/8	143	
45°	C6-45G0-18	18	27	9-9/16	7	9	17-7/16	13-3/4	29	6	9-1/2	5/8	5/16	54
	C6-45G0-24	24	33	9-11/16	9	11	22-1/4	15-5/16	35	6	9-1/2	5/8	5/16	65
	C6-45G0-30	30	39	9-11/16	11	13	27-1/8	16-3/4	41	6	9-1/2	5/8	5/16	77
	C6-45G0-36	36	45	9-11/16	13	15	31-15/16	18-3/16	47	6	9-1/2	5/8	5/16	87
	C6-45G0-42	42	51	10-1/16	15	17	36-3/4	19-15/16	53	7-1/2	9-1/2	5/8	5/16	105
	C6-45G0-48	48	57	10-1/16	17	19	41-5/8	21-3/8	59	7-1/2	9-1/2	5/8	5/16	116
	C6-45G0-54	54	63	10-1/2	19	21	46-7/16	23-3/16	65-1/2	9	11	5/8	3/8	135
C6-45G0-60	60	69	10-1/2	21	23-3/8	51-1/4	25-5/8	71-1/2	9	11	5/8	3/8	146	

Add "TTM", "DRY", "WET", "LOW" to the end of the part number to add application specific seals.

Recommended bolt pattern, see "Return & Flat Brackets Styles" section for minimum and maximum dimensions.

# CEMA C IDLERS

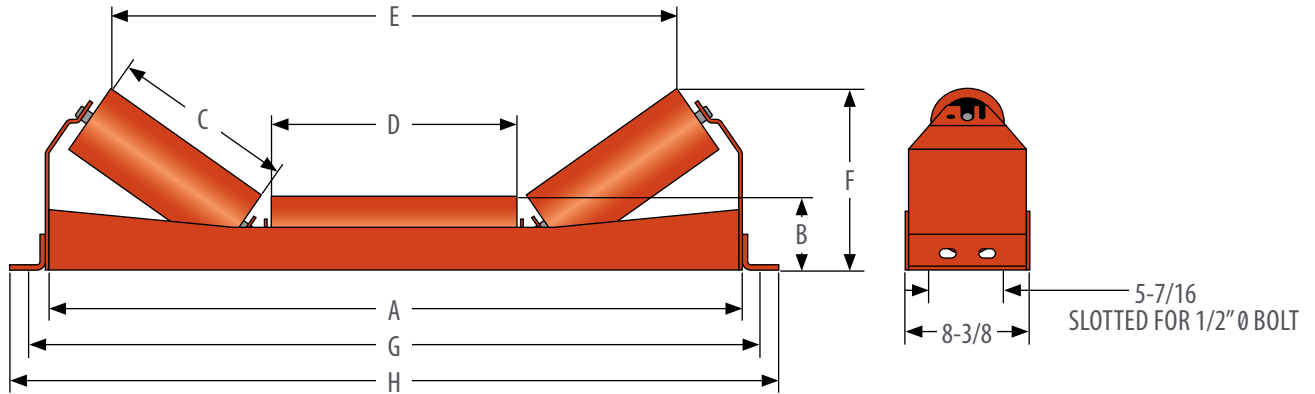

## LOW PROFILE STANDARD MOUNT: 4" AND 5" DIAMETER

	PART NUMBER		BW	A		B		C		D		E		F		G	H	WT (#)	
	4"	5"		4"	5"	4"	5"	4"	5"	4"	5"	4"	5"	4"	5"			4"	5"
20°	C4-20SM-18	C5-20SM-18	18	23-5/8	4-1/2	5	5-7/8	5-15/16	6-7/8	6-15/16	20-1/16	19-3/4	6-5/8	7-1/8	27	28-1/2	41	46	
	C4-20SM-20	C5-20SM-20	20	25-5/8	4-1/2	5	6-7/8	6-15/16	6-7/8	6-15/16	22	21-11/16	7	7-1/2	29	30-1/2	43	49	
	C4-20SM-24	C5-20SM-24	24	29-5/8	4-1/2	5	6-7/8	6-15/16	10-15/16	10-15/16	26	25-11/16	7	7-1/2	33	34-1/2	47	54	
	C4-20SM-30	C5-20SM-30	30	35-5/8	4-1/2	5	8-15/16	8-15/16	12-15/16	12-15/16	31-3/4	31-7/16	7-11/16	8-15/16	39	40-1/2	56	64	
	C4-20SM-36	C5-20SM-36	36	41-5/8	4-1/2	5	10-15/16	10-15/16	14-15/16	14-15/16	37-9/16	37-1/4	8-3/8	8-13/16	45	46-1/2	68	78	
	C4-20SM-42	C5-20SM-42	42	47-5/8	4-1/2	5	12-15/16	12-15/16	16-15/16	16-15/16	43-3/8	43	9-1/16	9-1/2	51	52-1/2	77	88	
	C4-20SM-48	C5-20SM-48	48	53-5/8	4-1/2	5	14-15/16	14-15/16	18-15/16	18-15/16	49	48-5/8	9-11/16	10-3/16	57	58-1/2	85	97	
	C4-20SM-54	C5-20SM-54	54	59-5/8	4-1/2	5	16-15/16	16-15/16	21-1/4	21-1/4	55-3/16	54-13/16	10-7/16	10-7/8	63	64-1/2	106	120	
C4-20SM-60	C5-20SM-60	60	65-5/8	4-1/2	5	18-15/16	18-15/16	23-1/4	23-1/4	60-7/8	60-9/16	11-1/8	11-9/16	69	70-1/2	115	131		
35°	C4-35SM-18	C5-35SM-18	18	23-5/8	4-1/2	5	5-7/8	5-15/16	6-7/8	6-15/16	18-1/4	17-3/4	8-1/16	8-7/16	27	28-1/2	43	49	
	C4-35SM-20	C5-35SM-20	20	25-5/8	4-1/2	5	6-7/8	6-15/16	6-7/8	6-15/16	19-15/16	19-3/8	8-5/8	9	29	30-1/2	46	52	
	C4-35SM-24	C5-35SM-24	24	29-5/8	4-1/2	5	6-7/8	6-15/16	10-15/16	10-15/16	23-15/16	23-7/16	8-3/8	9	33	34-1/2	51	58	
	C4-35SM-30	C5-35SM-30	30	35-5/8	4-1/2	5	8-15/16	8-15/16	12-15/16	12-15/16	29-3/16	28-11/16	9-13/16	10-3/16	39	40-1/2	59	68	
	C4-35SM-36	C5-35SM-36	36	41-5/8	4-1/2	5	10-15/16	10-15/16	14-15/16	14-15/16	34-5/8	34-1/8	11	11-5/16	45	46-1/2	72	82	
	C4-35SM-42	C5-35SM-42	42	47-5/8	4-1/2	5	12-15/16	12-15/16	16-15/16	16-15/16	39-11/16	39-3/16	12-1/8	12-7/16	51	52-1/2	81	92	
	C4-35SM-48	C5-35SM-48	48	53-5/8	4-1/2	5	14-15/16	14-15/16	18-15/16	18-15/16	45	44-7/16	13-1/4	13-5/8	57	58-1/2	89	101	
	C4-35SM-54	C5-35SM-54	54	59-5/8	4-1/2	5	16-15/16	16-15/16	21-1/4	21-1/4	50-9/16	49-15/16	14-3/8	14-3/4	63	64-1/2	110	124	
C4-35SM-60	C5-35SM-60	60	65-5/8	4-1/2	5	18-15/16	18-15/16	23-1/4	23-1/4	55-13/16	55-3/16	15-1/2	15-7/8	69	70-1/2	120	135		

Add "TTM", "DRY", "WET", "LOW" to the end of the part number to add application specific seals.

6-3/8" wide frame is available upon request.



# CEMA C IDLERS

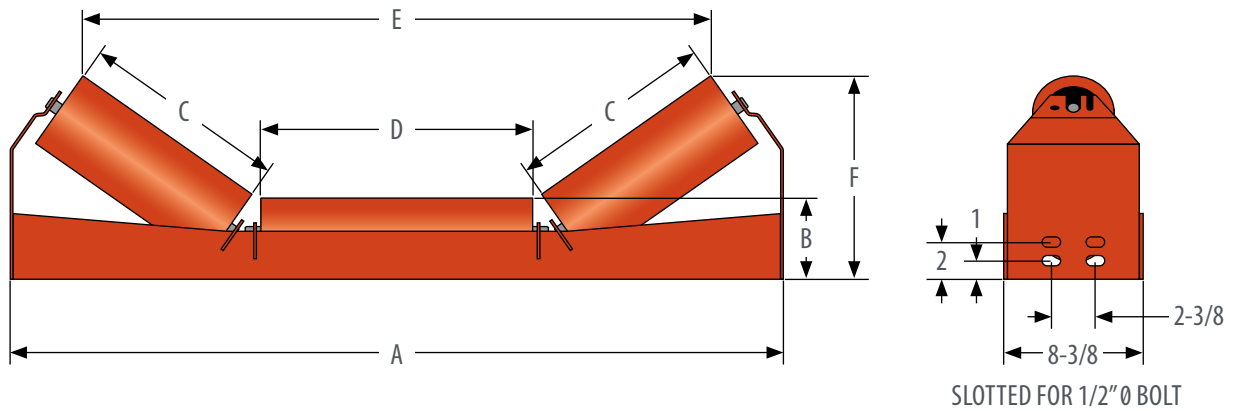

## CHANNEL MOUNT: 4" AND 5" DIAMETER

	PART NUMBER		BW	A	B		C		D		E		F		WT (#)	
	4"	5"			4"	5"	4"	5"	4"	5"	4"	5"	4"	5"	4"	5"
20°	C4-20CM-18	C5-20CM-18	18	23-5/8	4-1/2	5	5-7/8	5-15/16	6-7/8	6-15/16	19-13/16	19-1/2	6-5/8	7	36	42
	C4-20CM-20	C5-20CM-20	20	25-5/8	4-1/2	5	6-7/8	6-15/16	6-7/8	6-15/16	21-3/4	21-7/16	7	7-3/8	39	45
	C4-20CM-24	C5-20CM-24	24	29-5/8	4-1/2	5	6-7/8	6-15/16	10-15/16	10-15/16	25-3/4	25-7/16	7	7-5/16	43	50
	C4-20CM-30	C5-20CM-30	30	35-5/8	4-1/2	5	8-15/16	8-15/16	12-15/16	12-15/16	31-1/2	31-3/16	7-11/16	8	51	60
	C4-20CM-36	C5-20CM-36	36	41-5/8	4-1/2	5	10-15/16	10-15/16	14-15/16	14-15/16	37-5/16	37	8-3/8	8-11/16	63	73
	C4-20CM-42	C5-20CM-42	42	47-5/8	4-1/2	5	12-15/16	12-15/16	16-15/16	16-15/16	43-1/8	42-3/4	9-1/16	9-3/8	73	84
	C4-20CM-48	C5-20CM-48	48	53-5/8	4-1/2	5	14-15/16	14-15/16	18-15/16	18-15/16	48-3/4	48-3/8	9-11/16	10-1/16	81	93
	C4-20CM-54	C5-20CM-54	54	59-5/8	4-1/2	5	16-15/16	16-15/16	20-15/16	21-1/4	54-15/16	54-9/16	10-7/16	10-3/4	101	115
	C4-20CM-60	C5-20CM-60	60	65-5/8	4-1/2	5	18-15/16	18-15/16	22-15/16	23-1/4	60-5/8	60-5/16	11-1/8	11-7/16	111	126
	C4-35CM-18	C5-35CM-18	18	23-5/8	4-1/2	5	5-7/8	5-15/16	6-7/8	6-15/16	17-15/16	17-3/8	8-1/16	8-3/8	39	44
C4-35CM-20	C5-35CM-20	20	25-5/8	4-1/2	5	6-7/8	6-15/16	6-7/8	6-15/16	21-3/4	19-15/16	8-5/8	8-11/16	42	49	
C4-35CM-24	C5-35CM-24	24	29-5/8	4-1/2	5	6-7/8	6-15/16	10-15/16	10-15/16	23-11/16	23-1/8	8-5/8	8-15/16	46	53	
C4-35CM-30	C5-35CM-30	30	35-5/8	4-1/2	5	8-15/16	8-15/16	12-15/16	12-15/16	28-15/16	28-3/8	9-13/16	10-1/16	55	63	
C4-35CM-36	C5-35CM-36	36	41-5/8	4-1/2	5	10-15/16	10-15/16	14-15/16	14-15/16	34-5/16	33-3/4	11	11-1/4	67	77	
C4-35CM-42	C5-35CM-42	42	47-5/8	4-1/2	5	12-15/16	12-15/16	16-15/16	16-15/16	39-7/16	38-7/8	12-1/8	12-3/8	76	87	
C4-35CM-48	C5-35CM-48	48	53-5/8	4-1/2	5	14-15/16	14-15/16	18-15/16	18-15/16	44-11/16	44-1/8	13-1/4	13-1/2	84	97	
C4-35CM-54	C5-35CM-54	54	59-5/8	4-1/2	5	16-15/16	16-15/16	21-1/4	21-1/4	50-1/4	49-11/16	14-3/8	14-5/8	106	120	
C4-35CM-60	C5-35CM-60	60	65-5/8	4-1/2	5	18-15/16	18-15/16	22-15/16	23-1/4	55-1/2	54-15/16	15-1/2	15-13/16	115	131	

Add "TTM", "DRY", "WET", "LOW" to the end of the part number to add application specific seals.

6-3/8" wide frame is available upon request.

# CEMA C IDLERS

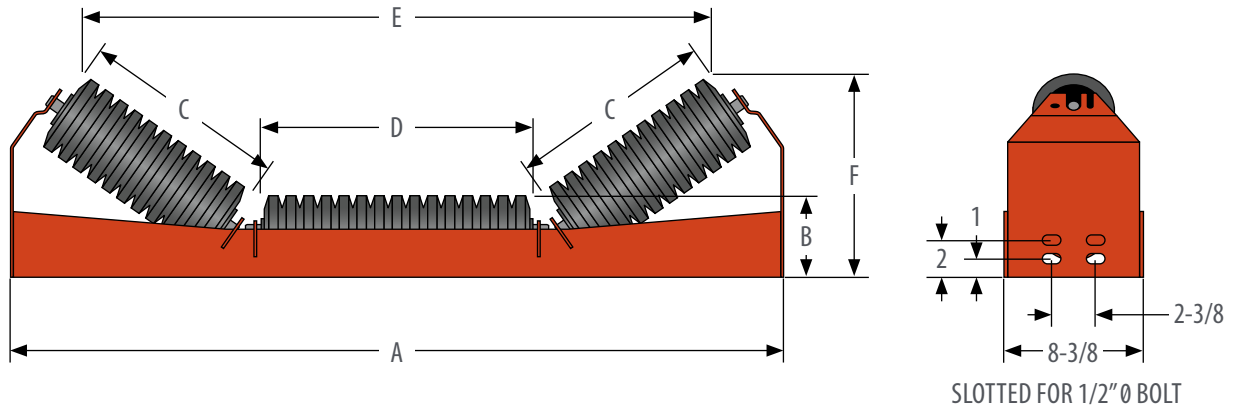

## CHANNEL MOUNT IMPACT IDLERS: 4" AND 5" DIAMETER

PART NUMBER		BW	A	B		C	D	E		F		WT (#)	
4"	5"			4"	5"			4"	5"	4"	5"	4"	5"
C4-20CMI-18	C5-20CMI-18	18	23-5/8	4-1/2	5	6	7	18-11/16	18-3/8	6-7/16	6-15/16	38	42
C4-20CMI-20	C5-20CMI-20	20	25-5/8	4-1/2	5	7	7	20-11/16	20-1/4	6-13/16	7-1/4	41	45
C4-20CMI-24	C5-20CMI-24	24	29-5/8	4-1/2	5	7	11	24-11/16	24-3/8	6-13/16	7-5/16	46	51
C4-20CMI-30	C5-20CMI-30	30	35-5/8	4-1/2	5	9	13	30-7/16	30-1/8	7-1/2	7-15/16	56	63
C4-20CMI-36	C5-20CMI-36	36	41-5/8	4-1/2	5	11	15	36-1/4	35-7/8	8-3/16	8-5/8	70	78
C4-20CMI-42	C5-20CMI-42	42	47-5/8	4-1/2	5	13	17	42	41-5/8	8-7/8	9-5/16	81	90
C4-20CMI-48	C5-20CMI-48	48	53-5/8	4-1/2	5	15	19	47-3/4	47-3/8	9-9/16	10	91	101
C4-20CMI-54	C5-20CMI-54	54	59-5/8	4-1/2	5	17	21-5/16	53-13/16	53-7/16	10-3/16	10-11/16	114	126
C4-20CMI-60	C5-20CMI-60	60	65-5/8	4-1/2	5	19	23-5/16	59-1/2	59-3/16	10-15/16	11-3/8	125	138
C4-35CMI-18	C5-35CMI-18	18	23-5/8	4-1/2	5	6	7	17	16-7/16	7-3/4	8-3/16	41	45
C4-35CMI-20	C5-35CMI-20	20	25-5/8	4-1/2	5	7	7	19-11/16	19-1/4	8-3/8	8-13/16	45	49
C4-35CMI-24	C5-35CMI-24	24	29-5/8	4-1/2	5	7	11	22-11/16	22-1/8	8-3/8	8-3/4	50	55
C4-35CMI-30	C5-35CMI-30	30	35-5/8	4-1/2	5	9	13	28	27-7/16	9-1/2	9-7/8	60	66
C4-35CMI-36	C5-35CMI-36	36	41-5/8	4-1/2	5	11	15	33-5/16	32-11/16	10-5/8	11-1/16	74	82
C4-35CMI-42	C5-35CMI-42	42	47-5/8	4-1/2	5	13	17	38-9/16	37-15/16	11-13/16	12-1/4	84	93
C4-35CMI-48	C5-35CMI-48	48	53-5/8	4-1/2	5	15	19	43-13/16	43-1/4	12-15/16	13-3/8	95	105
C4-35CMI-54	C5-35CMI-54	54	59-5/8	4-1/2	5	17	21-5/16	49-7/16	48-13/16	14-1/16	14-1/2	118	130
C4-35CMI-60	C5-35CMI-60	60	65-5/8	4-1/2	5	19	23-5/16	54-5/8	54-1/16	15-1/4	15-5/8	130	143

Add "TTM", "DRY", "WET", "LOW" to the end of the part number to add application specific seals.

6 -3/8" wide frame is available upon request.

# CEMA D IDLERS

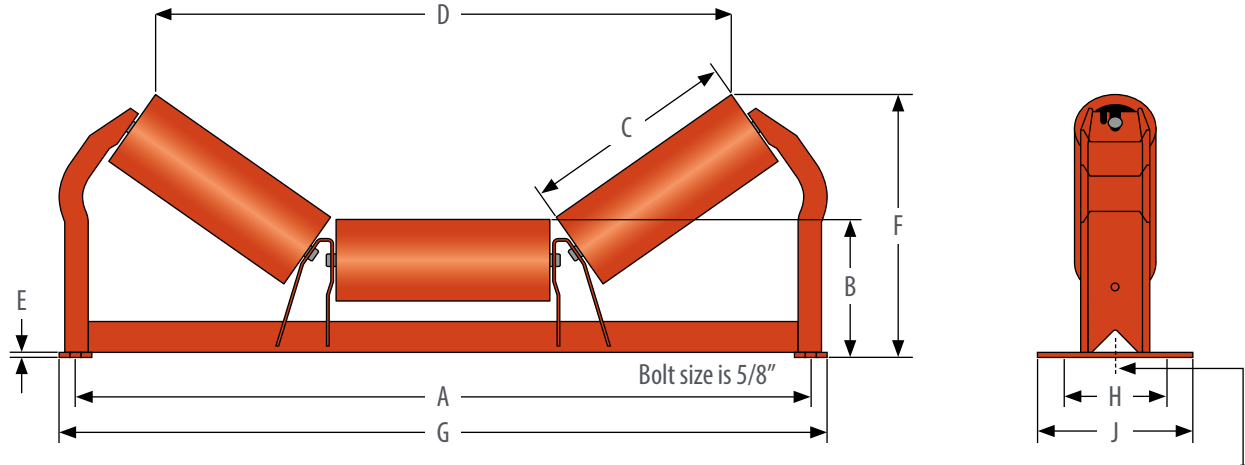

Center slot for single bolt mounting through 48" belt width

## TROUGHING IDLERS (EQUAL LENGTH ROLLERS): 5" AND 6" DIAMETER

	PART NUMBER		BW	A	B		C	D		E	F		G	H	J	WT (#)	
	5"	6"			5"	6"		5"	6"		5"	6"				5"	6"
20°	D5-20E-24	D6-20E-24	24	33	8-1/2	9	9-1/16	27-11/16	27-5/16	5/16	11-11/16	12-1/8	35	6	9-1/2	54	64
	D5-20E-30	D6-20E-30	30	39	8-1/2	9	11-1/16	33-7/16	33-1/8	5/16	12-3/8	12-13/16	41	6	9-1/2	64	76
	D5-20E-36	D6-20E-36	36	45	8-1/2	9	13-1/16	39-3/16	38-7/8	5/16	13-1/16	13-1/2	47	6	9-1/2	71	86
	D5-20E-42	D6-20E-42	42	51	8-7/8	9-3/8	15-1/16	44-15/16	44-5/8	5/16	14-1/8	14-5/8	53	7-1/2	9-1/2	87	104
	D5-20E-48	D6-20E-48	48	57	9-1/4	9-3/4	17-1/16	51	50-11/16	5/16	14-7/8	15-5/16	59	7-1/2	9-1/2	101	119
	D5-20E-54	D6-20E-54	54	63	9-5/16	9-13/16	19-1/16	56-1/2	56-1/8	3/8	15-15/16	16-3/8	65-1/2	9	11	113	133
	D5-20E-60	D6-20E-60	60	69	9-5/16	9-13/16	21-1/16	62-1/4	61-7/8	3/8	16-5/8	17-1/16	71-1/2	9	11	122	144
35°	D5-20E-72	D6-20E-72	72	81	9-5/16	9-13/16	25-1/16	73-3/4	73-3/8	3/8	18	18-7/16	83-1/2	9	11	140	166
	D5-35E-24	D6-35E-24	24	33	8-1/2	9	9-1/16	24-3/4	24-3/16	5/16	13-3/4	14-3/16	35	6	9-1/2	56	66
	D5-35E-30	D6-35E-30	30	39	8-1/2	9	11-1/16	30	29-7/16	5/16	14-15/16	15-3/8	41	6	9-1/2	66	78
	D5-35E-36	D6-35E-36	36	45	8-1/2	9	13-1/16	35-5/16	34-3/4	5/16	16-1/8	16-1/2	47	6	9-1/2	74	88
	D5-35E-42	D6-35E-42	42	51	8-7/8	9-3/8	15-1/16	40-9/16	40	5/16	17-5/8	18-1/16	53	7-1/2	9-1/2	90	107
	D5-35E-48	D6-35E-48	48	57	9-1/4	9-3/4	17-1/16	46-1/4	45-11/16	5/16	18-15/16	19-5/16	59	7-1/2	9-1/2	104	122
	D5-35E-54	D6-35E-54	54	63	9-5/16	9-13/16	19-1/16	51-1/8	50-9/16	3/8	20-3/8	20-3/4	65-1/2	9	11	117	137
45°	D5-35E-60	D6-35E-60	60	69	9-5/16	9-13/16	21-1/16	56-7/16	55-13/16	3/8	21-1/2	21-7/8	71-1/2	9	11	126	148
	D5-35E-72	D6-35E-72	72	81	9-5/16	9-13/16	25-1/16	66-15/16	66-3/8	3/8	23-13/16	24-3/16	83-1/2	9	11	145	171
	D5-45E-24	D6-45E-24	24	33	8-1/2	9	9-1/16	22-13/16	22-1/8	5/16	15-1/16	15-3/8	35	6	9-1/2	57	67
	D5-45E-30	D6-45E-30	30	39	8-1/2	9	11-1/16	27-11/16	27	5/16	16-1/2	16-13/16	41	6	9-1/2	68	80
	D5-45E-36	D6-45E-36	36	45	8-1/2	9	13-1/16	32-1/2	31-3/16	5/16	17-15/16	18-1/4	47	6	9-1/2	76	90
	D5-45E-42	D6-45E-42	42	51	8-7/8	9-3/8	15-1/16	37-3/8	36-11/16	5/16	19-11/16	20-1/16	53	7-1/2	9-1/2	92	109
	D5-45E-48	D6-45E-48	48	57	9-1/4	9-3/4	17-1/16	42-9/16	41-7/8	5/16	21-5/16	21-5/8	59	7-1/2	9-1/2	106	125
D5-45E-54	D6-45E-54	54	63	9-5/16	9-13/16	19-1/16	47	46-5/16	3/8	22-15/16	23-5/16	65-1/2	9	11	119	139	
D5-45E-60	D6-45E-60	60	69	9-5/16	9-13/16	21-1/16	51-7/8	51-3/16	3/8	24-3/8	24-11/16	71-1/2	9	11	129	151	
D5-45E-72	D6-45E-72	72	81	9-5/16	9-13/16	25-1/16	61-1/2	60-13/16	3/8	27-3/16	27-9/16	83-1/2	9	11	148	174	

Add "TTM", "DRY", "WET", "LOW" to the end of the part number to add application specific seals.

Add "MOX" to the end of the part number to replace steel cans with Moxie Rolls.

Recommended bolt pattern, see "Return & Flat Brackets Styles" section for minimum and maximum dimensions.

# CEMA D IDLERS

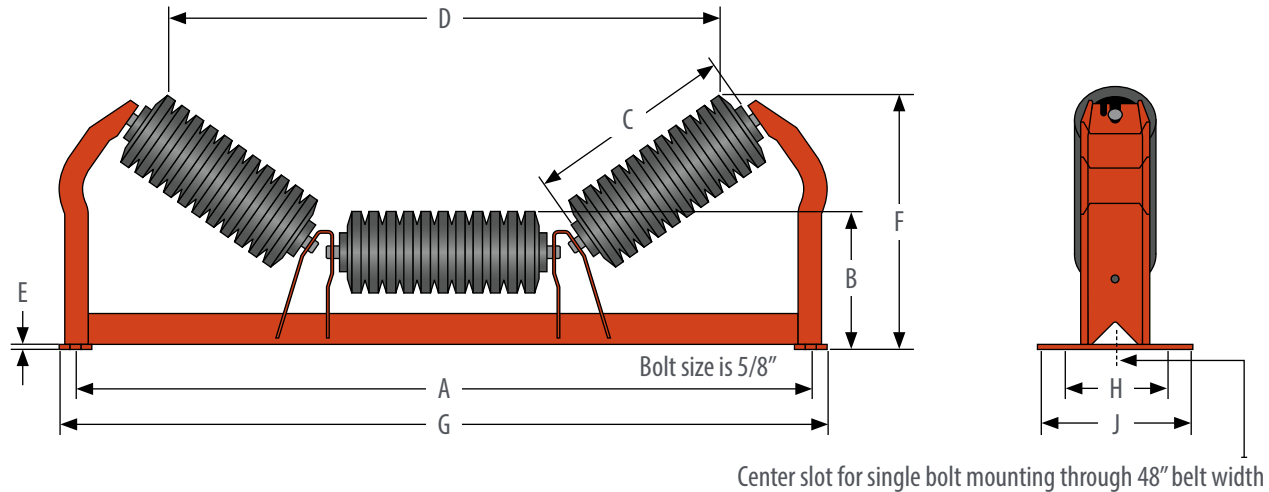

## RUBBER CUSHION IMPACT TROUGHING IDLER: 5" AND 6" DIAMETER

	PART NUMBER		BW	A		B		C	D		E	F		G	H	J	WT (#)	
	5"	6"		5"	6"	5"	6"		5"	6"		5"	6"				5"	6"
20°	D5-20EI-24	D6-20EI-24	24	33	8-1/2	9	9-1/8	26-5/16	25-15/16	5/16	11-1/2	11-15/16	35	6	9-1/2	61	68	
	D5-20EI-30	D6-20EI-30	30	39	8-1/2	9	11-1/8	32-1/8	31-3/4	5/16	12-3/16	12-11/16	41	6	9-1/2	74	82	
	D5-20EI-36	D6-20EI-36	36	45	8-1/2	9	13-1/8	37-7/8	37-1/2	5/16	12-7/8	13-3/8	47	6	9-1/2	92	94	
	D5-20EI-42	D6-20EI-42	42	51	8-7/8	9-3/8	15-1/8	43-5/8	43-1/4	5/16	13-15/16	14-7/16	53	7-1/2	9-1/2	112	123	
	D5-20EI-48	D6-20EI-48	48	57	9-1/4	9-3/4	17-1/8	49-11/16	49-5/16	5/16	14-11/16	15-3/16	59	7-1/2	9-1/2	129	141	
	D5-20EI-54	D6-20EI-54	54	63	9-5/16	9-13/16	19-1/8	55-1/8	54-3/4	3/8	15-3/4	16-3/16	65-1/2	9	11	146	160	
	D5-20EI-60	D6-20EI-60	60	69	9-5/16	9-13/16	21-1/8	60-7/8	60-1/2	3/8	16-7/16	16-7/8	71-1/2	9	11	159	175	
35°	D5-20EI-72	D6-20EI-72	72	81	9-5/16	9-13/16	25-1/8	72-3/8	72	3/8	17-13/16	18-1/4	83-1/2	9	11	183	202	
	D5-35EI-24	D6-35EI-24	24	33	8-1/2	9	9-1/8	23-1/2	22-15/16	5/16	13-7/16	13-7/8	35	6	9-1/2	63	70	
	D5-35EI-30	D6-35EI-30	30	39	8-1/2	9	11-1/8	28-13/16	28-3/16	5/16	14-5/8	15-1/16	41	6	9-1/2	76	85	
	D5-35EI-36	D6-35EI-36	36	45	8-1/2	9	13-1/8	34-1/16	33-1/2	5/16	15-13/16	16-3/16	47	6	9-1/2	95	97	
	D5-35EI-42	D6-35EI-42	42	51	8-7/8	9-3/8	15-1/8	39-5/16	38-3/4	5/16	17-5/16	17-3/4	53	7-1/2	9-1/2	116	127	
	D5-35EI-48	D6-35EI-48	48	57	9-1/4	9-3/4	17-1/8	44-15/16	44-7/16	5/16	18-5/8	19	59	7-1/2	9-1/2	132	145	
	D5-35EI-54	D6-35EI-54	54	63	9-5/16	9-13/16	19-1/8	49-7/8	49-5/16	3/8	20	20-7/16	65-1/2	9	11	150	165	
45°	D5-35EI-60	D6-35EI-60	60	69	9-5/16	9-13/16	21-1/8	55-1/8	54-9/16	3/8	21-3/16	21-9/16	71-1/2	9	11	163	179	
	D5-35EI-72	D6-35EI-72	72	81	9-5/16	9-13/16	25-1/8	65-11/16	65-1/8	3/8	23-1/2	23-7/8	83-1/2	9	11	188	207	
	D5-45EI-24	D6-45EI-24	24	33	8-1/2	9	9-1/8	21-11/16	21	5/16	14-5/8	15	35	6	9-1/2	64	71	
	D5-45EI-30	D6-45EI-30	30	39	8-1/2	9	11-1/8	26-9/16	25-7/8	5/16	16-1/16	16-7/16	41	6	9-1/2	78	86	
	D5-45EI-36	D6-45EI-36	36	45	8-1/2	9	13-1/8	31-7/16	30-11/16	5/16	17-1/2	17-7/16	47	6	9-1/2	97	99	
	D5-45EI-42	D6-45EI-42	42	51	8-7/8	9-3/8	15-1/8	36-3/16	35-1/2	5/16	19-5/16	16-5/8	53	7-1/2	9-1/2	118	129	
	D5-45EI-48	D6-45EI-48	48	57	9-1/4	9-3/4	17-1/8	41-7/16	40-3/4	5/16	20-15/16	21-1/4	59	7-1/2	9-1/2	135	148	
D5-45EI-54	D6-45EI-54	54	63	9-5/16	9-13/16	19-1/8	45-7/8	45-3/16	3/8	22-9/16	22-7/8	65-1/2	9	11	152	167		
D5-45EI-60	D6-45EI-60	60	69	9-5/16	9-13/16	21-1/8	50-11/16	50	3/8	23-15/16	24-5/16	71-1/2	9	11	166	183		
D5-45EI-72	D6-45EI-72	72	81	9-5/16	9-13/16	25-1/8	60-3/8	59-5/8	3/8	26-13/16	27-1/8	83-1/2	9	11	191	211		

Add "TTM", "DRY", "WET", "LOW" to the end of the part number to add application specific seals.

Add "MOX" to the end of the part number to replace steel cans with Moxie Rolls.

Recommended bolt pattern, see "Return & Flat Brackets Styles" section for minimum and maximum dimensions.

# CEMA D IDLERS

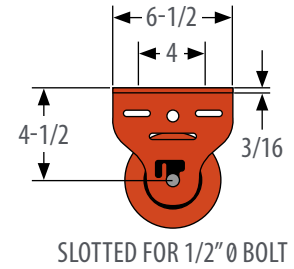
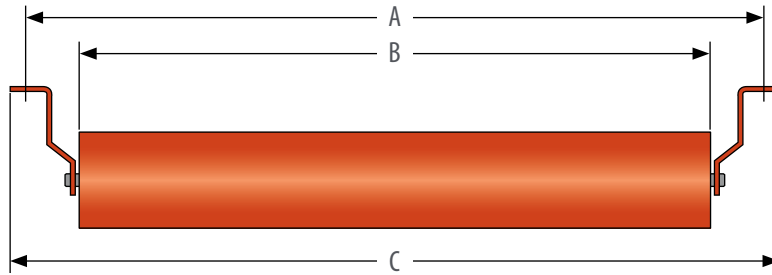

## RETURN IDLERS: 5" AND 6" DIAMETER

PART NUMBER		BW	A	B	C	WT (#)	
5"	6"					5"	6"
D5-RET-18	D6-RET-18	18	27	21-3/8	28-7/16	25	33
D5-RET-20	D6-RET-20	20	29	23-3/8	30-7/16	27	34
D5-RET-24	D6-RET-24	24	33	27-3/8	34-7/16	30	40
D5-RET-30	D6-RET-30	30	39	33-3/8	40-7/16	36	47
D5-RET-36	D6-RET-36	36	45	39-3/8	46-7/16	41	54
D5-RET-42	D6-RET-42	42	51	45-3/8	52-7/16	46	61
D5-RET-48	D6-RET-48	48	57	51-3/8	58-7/16	51	68
D5-RET-54	D6-RET-54	54	63	57-3/8	64-7/16	56	76
D5-RET-60	D6-RET-60	60	69	63-3/8	70-7/16	61	83
D5-RET-72	D6-RET-72	72	81	75-3/8	82-7/16	72	97

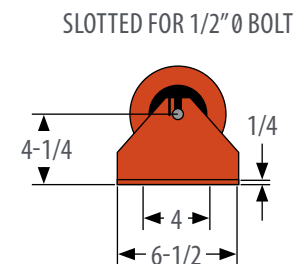
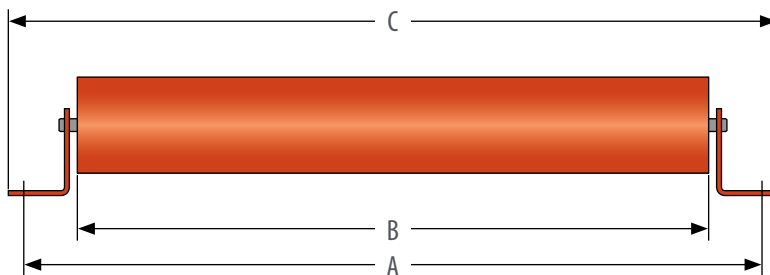

## FLAT IDLERS: 5" AND 6" DIAMETER

PART NUMBER		BW	A	B	C	WT (#)	
5"	6"					5"	6"
D5-RET-18	D6-RET-18	18	27	21-3/8	28-15/16	28	37
D5-RET-20	D6-RET-20	20	29	23-3/8	30-15/16	30	37
D5-RET-24	D6-RET-24	24	33	27-3/8	34-15/16	33	43
D5-RET-30	D6-RET-30	30	39	33-3/8	40-15/16	38	50
D5-RET-36	D6-RET-36	36	45	39-3/8	46-15/16	43	57
D5-RET-42	D6-RET-42	42	51	45-3/8	52-15/16	49	64
D5-RET-48	D6-RET-48	48	57	51-3/8	58-15/16	54	71
D5-RET-54	D6-RET-54	54	63	57-3/8	64-15/16	59	78
D5-RET-60	D6-RET-60	60	69	63-3/8	70-15/16	64	85
D5-RET-72	D6-RET-72	72	81	75-3/8	82-15/16	74	99

Add "TTM", "DRY", "WET", "LOW" to the end of the part number to add application specific seals.

Add "MOX" to the end of the part number to replace steel cans with Moxie Rolls.

Recommended bolt pattern, see "Return & Flat Brackets Styles" section for minimum and maximum dimensions.

# CEMA D IDLERS

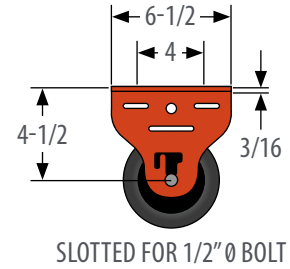
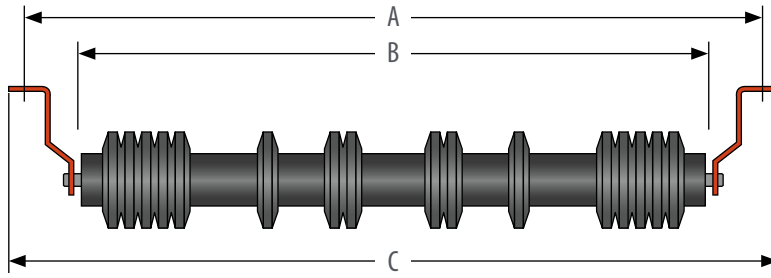

## RUBBER CUSHION RETURN IDLERS: 5" AND 6" DIAMETER

PART NUMBER		BW	A	B	C	WT (#)	
5"	6"					5"	6"
D5-RETI-18	D6-RETI-18	18	27	21-7/16	28-7/16	31	34
D5-RETI-20	D6-RETI-20	20	29	23-7/16	30-7/16	34	37
D5-RETI-24	D6-RETI-24	24	33	27-7/16	34-7/16	38	42
D5-RETI-30	D6-RETI-30	30	39	33-7/16	40-7/16	45	49
D5-RETI-36	D6-RETI-36	36	45	39-7/16	46-7/16	52	57
D5-RETI-42	D6-RETI-42	42	51	45-7/16	52-7/16	59	63
D5-RETI-48	D6-RETI-48	48	57	51-7/16	58-7/16	65	70
D5-RETI-54	D6-RETI-54	54	63	57-7/16	64-7/16	72	77
D5-RETI-60	D6-RETI-60	60	69	63-7/16	70-7/16	79	85
D5-RETI-72	D6-RETI-72	72	81	75-7/16	82-7/16	93	99

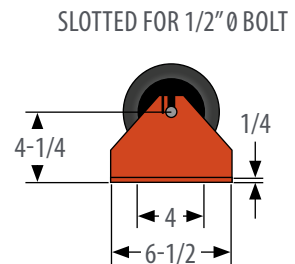
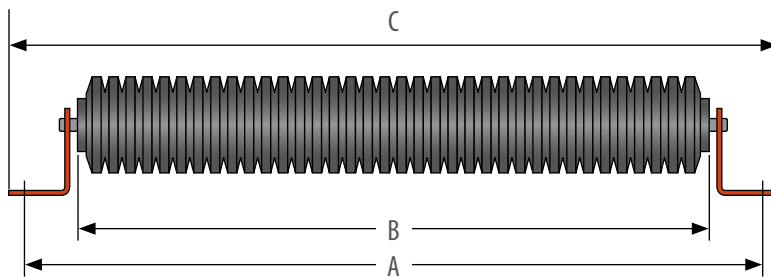

## RUBBER CUSHION FLAT IDLERS: 5" AND 6" DIAMETER

PART NUMBER		BW	A	B	C	WT(#)	
5"	6"					5"	6"
D5-FLTI-24	D6-FLTI-24	24	33	27-7/16	34-15/16	45	52
D5-FLTI-30	D6-FLTI-30	30	39	33-7/16	40-15/16	53	62
D5-FLTI-36	D6-FLTI-36	36	45	39-7/16	46-15/16	61	71
D5-FLTI-42	D6-FLTI-42	42	51	45-7/16	52-15/16	69	81
D5-FLTI-48	D6-FLTI-48	48	57	51-7/16	58-15/16	78	92
D5-FLTI-54	D6-FLTI-54	54	63	57-7/16	64-15/16	86	101
D5-FLTI-60	D6-FLTI-60	60	69	63-7/16	70-15/16	94	111
D5-FLTI-72	D6-FLTI-72	72	81	75-7/16	82-15/16	111	131

Add "TTM", "DRY", "WET", "LOW" to the end of the part number to add application specific seals.

Individual bracket weights are listed on "Return & Flat Brackets Styles" section. Brackets sold separately.

# CEMA D IDLERS

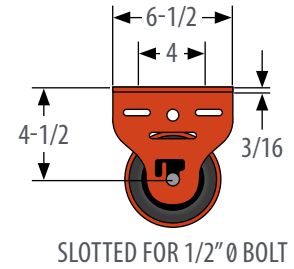
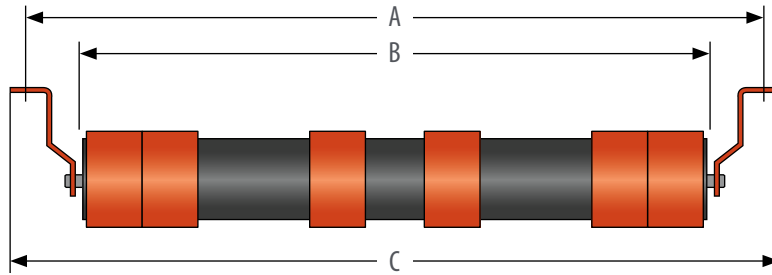

## URATHON® RETURN ROLLS: 5" AND 6" DIAMETER

PART NUMBER		BW	A	B	C	WT (#)	
5"	6"					5"	6"
D5-RETU-18	D6-RETU-18	18	27	21-3/8	28-7/16	24	31
D5-RETU-24	D6-RETU-24	24	33	27-3/8	34-7/16	28	37
D5-RETU-30	D6-RETU-30	30	39	33-3/8	40-7/16	33	43
D5-RETU-36	D6-RETU-36	36	45	39-3/8	46-7/16	38	49
D5-RETU-42	D6-RETU-42	42	51	45-3/8	52-7/16	42	55
D5-RETU-48	D6-RETU-48	48	57	51-3/8	58-7/16	47	61
D5-RETU-54	D6-RETU-54	54	63	57-3/8	64-7/16	51	67
D5-RETU-60	D6-RETU-60	60	69	63-3/8	70-7/16	56	73
D5-RETU-72	D6-RETU-72	72	81	75-3/8	82-7/16	67	88

Add "TTM", "DRY", "WET", "LOW" to the end of the part number to add application specific seals.

Spiral Urathon is only available in 6" diameter. To order Spiral Urathon version add "SP" after "RETU" in the part number.

Individual bracket weights are listed on "Return & Flat Brackets Styles" section. Brackets sold separately.

# CEMA D IDLERS

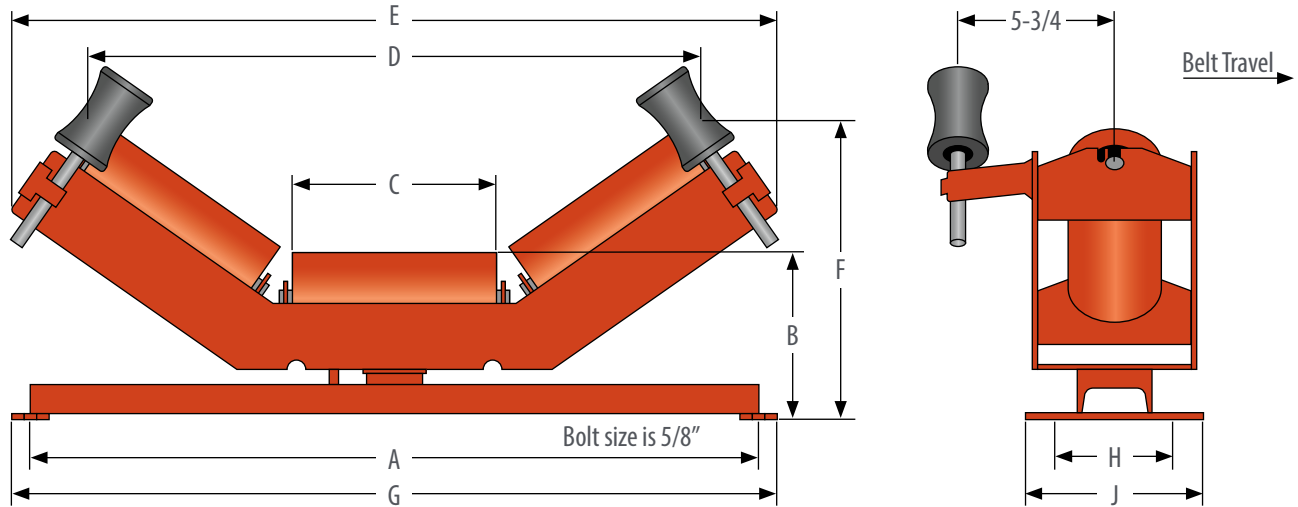

## SELF-ALIGNING TROUGHING IDLERS: 5" AND 6" DIAMETER

	PART NUMBER		BW	A	B		C	D		E	F		G	H	J	L	WT (#)	
	5"	6"			5"	6"		5"	6"		5"	6"					5"	6"
20°	D5-20EA-24	D6-20EA-24	24	33	9-1/8	9-5/8	9-1/16	28-9/16	28-1/4	36-3/4	12-7/16	12-15/16	35	6	9-1/2	5/16	104	115
	D5-20EA-30	D6-20EA-30	30	39	9-1/8	9-5/8	11-1/16	34-5/16	34	42-9/16	13-1/8	13-5/8	41	6	9-1/2	5/16	127	139
	D5-20EA-36	D6-20EA-36	36	45	9-1/8	9-5/8	13-1/16	40-1/16	39-3/4	48-5/16	13-13/16	14-5/16	47	6	9-1/2	5/16	140	154
	D5-20EA-42	D6-20EA-42	42	51	9-5/8	10-1/8	15-1/16	45-11/16	45-5/16	54-3/16	15	15-5/16	53	7-1/2	9-1/2	5/16	157	173
	D5-20EA-48	D6-20EA-48	48	57	9-5/8	10-1/8	17-1/16	51-7/16	51-1/16	60	15-11/16	16-1/8	59	7-1/2	9-1/2	5/16	170	189
	D5-20EA-54	D6-20EA-54	54	63	9-11/16	10-3/16	19-1/16	57-3/16	56-13/16	65-3/4	18-7/16	16-7/8	65-1/2	9-1/2	11	3/8	186	207
	D5-20EA-60	D6-20EA-60	60	69	9-11/16	10-3/16	21-1/16	62-15/16	62-5/8	71-1/2	17-1/8	17-7/16	71-1/2	9	11	3/8	200	222
	D5-20EA-72	D6-20EA-72	72	81	9-11/16	10-3/16	25-1/16	74-1/2	74-7/16	83	18-1/2	18-15/16	83-1/2	9	11	3/8	227	252
35°	D5-35EA-24	D6-35EA-24	24	33	9-1/8	9-5/8	9-1/16	24-15/16	24-3/8	35-5/8	14-1/2	14-15/16	35	6	9-1/2	5/16	105	115
	D5-35EA-30	D6-35EA-30	30	39	9-1/8	9-5/8	11-1/16	30-3/16	29-5/8	40-15/16	15-11/16	16-1/16	41	6	9-1/2	5/16	127	140
	D5-35EA-36	D6-35EA-36	36	45	9-1/8	9-5/8	13-1/16	35-1/2	34-15/16	46-3/16	16-13/16	17-1/16	47	6	9-1/2	5/16	140	155
	D5-35EA-42	D6-35EA-42	42	51	9-5/8	10-1/8	15-1/16	40-7/16	39-7/8	51-3/4	18-7/16	18-11/16	53	7-1/2	9-1/2	5/16	157	174
	D5-35EA-48	D6-35EA-48	48	57	9-5/8	10-1/8	17-1/16	45-3/4	45-1/8	57	19-7/16	20	59	7-1/2	9-1/2	5/16	171	189
	D5-35EA-54	D6-35EA-54	54	63	9-11/16	10-3/16	19-1/16	51	50-7/16	62-1/4	20-13/16	21-1/16	65-1/2	7-1/2	11	3/8	187	207
	D5-35EA-60	D6-35EA-60	60	69	9-11/16	10-3/16	21-1/16	56-1/4	55-11/16	67-9/16	21-15/16	22-3/16	71-1/2	9	11	3/8	201	223
	D5-35EA-72	D6-35EA-72	72	81	9-11/16	10-3/16	25-1/16	66-13/16	66-1/4	78-1/8	24-1/4	24-5/8	83-1/2	9	11	3/8	228	254
45°	D5-45EA-24	D6-45EA-24	24	33	9-1/8	9-5/8	9-1/16	23-1/2	22-13/16	35-1/2	15-1/2	15-13/16	35	6	9-1/2	5/16	106	117
	D5-45EA-30	D6-45EA-30	30	39	9-1/8	9-5/8	11-1/16	28-5/16	27-5/8	40-5/16	17	17-5/16	41	6	9-1/2	5/16	128	141
	D5-45EA-36	D6-45EA-36	36	45	9-1/8	9-5/8	13-1/16	33-1/8	32-7/16	45-3/16	18-7/16	18-3/4	47	6	9-1/2	5/16	142	156
	D5-45EA-42	D6-45EA-42	42	51	9-5/8	10-1/8	15-1/16	37-9/16	36-7/8	50-5/16	20-5/16	20-1/2	53	7-1/2	9-1/2	5/16	159	175
	D5-45EA-48	D6-45EA-48	48	57	9-5/8	10-1/8	17-1/16	42-3/8	41-11/16	55-1/8	21-3/4	21-15/16	59	7-1/2	9-1/2	5/16	172	191
	D5-45EA-54	D6-45EA-54	54	63	9-11/16	10-3/16	19-1/16	47-3/16	46-1/2	59-15/16	23-3/16	23-7/16	65-1/2	7-1/2	11	3/8	189	209
	D5-45EA-60	D6-45EA-60	60	69	9-11/16	10-3/16	21-1/16	52-1/16	51-3/8	64-3/4	24-1/2	24-15/16	71-1/2	9	11	3/8	202	224
	D5-45EA-72	D6-45EA-72	72	81	9-11/16	10-3/16	25-1/16	61-11/16	61	74-7/16	27-7/16	27-13/16	83-1/2	9	11	3/8	229	255

Add "TTM", "DRY", "WET", "LOW" to the end of the part number to add application specific seals.

Also available in bi-directional shoe-activating. Designated by "BA".

Individual bracket weights are listed on "Return & Flat Brackets Styles" section. Brackets sold separately.



# CEMA D IDLERS

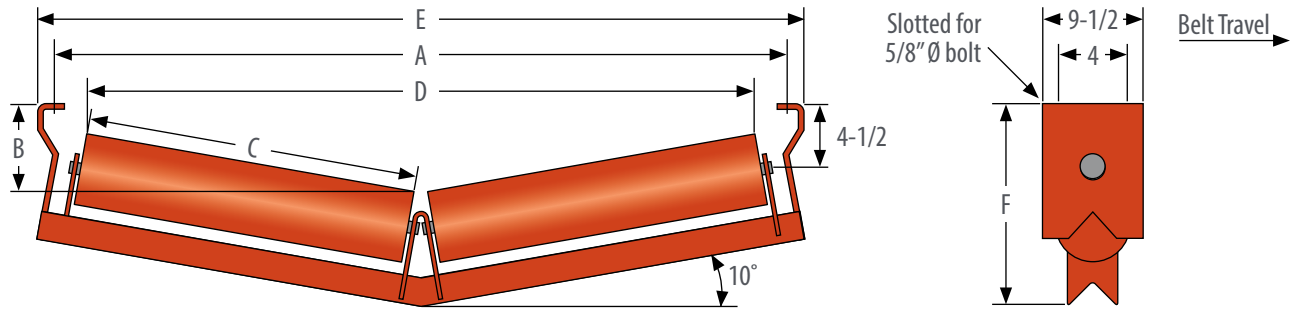

For wider base use next size larger belt width. Also available in 15°.

## V-RETURN IDLER: 5" AND 6" DIAMETER

PART NUMBER		BW	A	B		C	D		E	F	WT (#)	
5"	6"			5"	6"		5"	6"			5"	6"
D5-10RETV-24	D6-10RETV-24	24	33	4-3/8	3-7/8	14-3/8	29	28-9/16	35-1/8	12-3/8	58	68
D5-10RETV-30	D6-10RETV-30	30	39	4-7/8	4-3/8	17	34-5/16	33-7/8	41-1/8	12-7/8	64	76
D5-10RETV-36	D6-10RETV-36	36	45	5-7/16	4-15/16	20-1/2	41-1/16	40-5/8	47-1/8	13-3/8	71	86
D5-10RETV-42	D6-10RETV-42	42	51	5-15/16	5-7/16	23-3/8	46-11/16	46-1/4	53-1/8	14	78	92
D5-10RETV-48	D6-10RETV-48	48	57	6-7/16	6	26-1/2	53	52-9/16	59-1/8	14-1/2	85	103
D5-10RETV-54	D6-10RETV-54	54	63	7	6-1/2	29-1/4	58-5/16	57-7/8	65-1/8	15-3/8	107	127
D5-10RETV-60	D6-10RETV-60	60	69	7-1/2	7-1/16	32-1/2	64-13/16	64-3/8	71-1/8	15-7/8	116	138
D5-10RETV-66	D6-10RETV-66	66	75	8-1/16	7-9/16	35-3/4	71-1/8	70-11/16	77-1/8	16-3/8	125	149
D5-10RETV-72	D6-10RETV-72	72	81	8-9/16	8-1/16	38	75-5/8	75-3/16	83-1/8	17	132	157
D5-10RETV-78	D6-10RETV-78	78	87	9-1/8	8-5/8	41-1/4	82	81-9/16	89-1/8	17-1/2	140	164

Add "TTM", "DRY", "WET", "LOW" to the end of the part number to add application specific seals.

Individual bracket weights are listed on "Return & Flat Brackets Styles" section. Brackets sold separately.

# CEMA D IDLERS

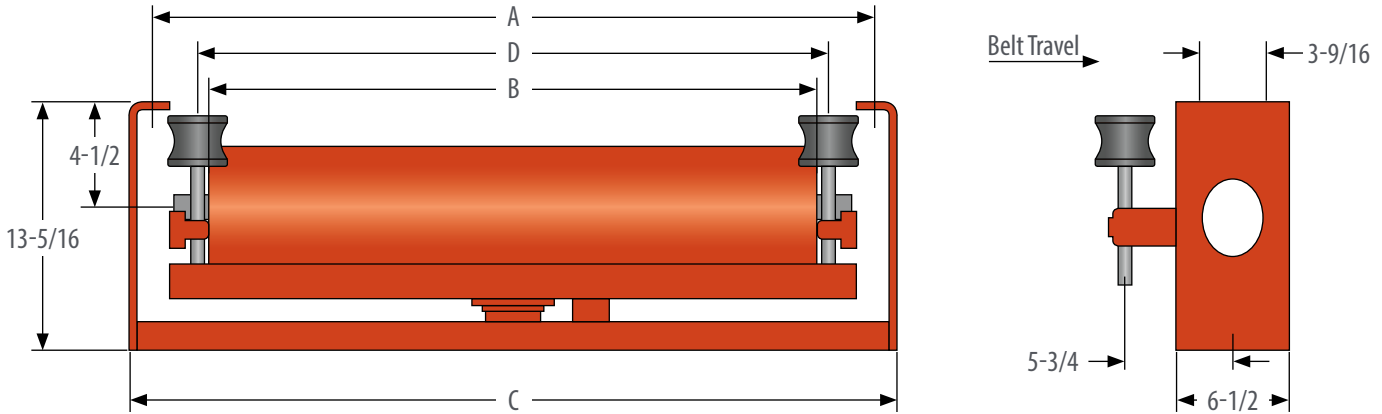

## SELF-ALIGNING RETURN IDLERS: 5" AND 6" DIAMETER

PART NUMBER		BW	A	B	C	D	WT (#)	
5"	6"						5"	6"
D5-RETA-18	D6-RETA-18	18	27	21-3/8	29-1/2	25-5/8	72	80
D5-RETA-24	D6-RETA-24	24	33	27-3/8	35-1/2	31-5/8	81	91
D5-RETA-30	D6-RETA-30	30	39	33-3/8	41-1/2	37-5/8	94	105
D5-RETA-36	D6-RETA-36	36	45	39-3/8	47-1/2	43-5/8	104	117
D5-RETA-42	D6-RETA-42	42	51	45-3/8	53-1/2	49-5/8	122	137
D5-RETA-48	D6-RETA-48	48	57	51-3/8	59-1/2	55-5/8	133	150
D5-RETA-54	D6-RETA-54	54	63	57-3/8	65-1/2	61-5/8	144	163
D5-RETA-60	D6-RETA-60	60	69	63-3/8	71-1/2	67-5/8	155	176
D5-RETA-72	D6-RETA-72	72	81	75-3/8	83-1/2	79-5/8	177	202

Add "TTM", "DRY", "WET", "LOW" to the end of the part number to add application specific seals.

Also available in bi-directional shoe-activated option. Designated by "RETBA".

Self-aligning return idlers are also available in lagged roller. Designated by "RETAI".

Individual bracket weights are listed on "Return & Flat Brackets Styles" section. Brackets sold separately.

Bigfoot bolting pattern and lagged roller option available.

# CEMA D IDLERS

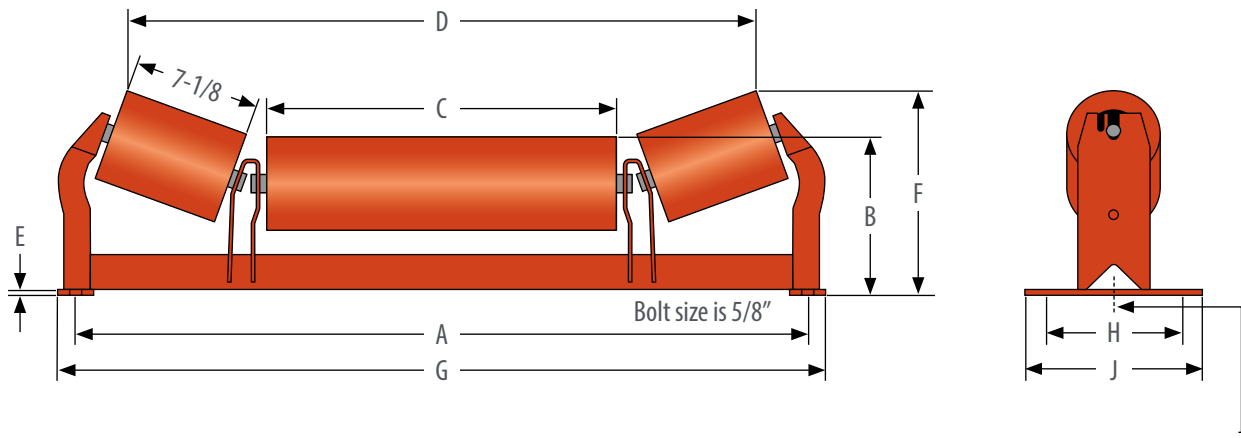

Center slot for single bolt mounting through 48" belt width

## FEEDER / PICKING TROUGHING IDLERS: 5" AND 6" DIAMETER

PART NUMBER		BW	A	B		C	D		E	F		G	H	J	WT (#)	
5"	6"			5"	6"		5"	6"		5"	6"				5"	6"
D5-20P-24	D6-20P-24	24	33	8-1/2	9	13	27-3/4	27-3/8	5/16	11	11-7/16	35	6	9-1/2	53	63
D5-20P-30	D6-20P-30	30	39	8-1/2	9	19	33-3/4	33-7/16	5/16	11	11-7/16	41	6	9-1/2	63	75
D5-20P-36	D6-20P-36	36	45	8-1/2	9	25	39-3/4	39-7/16	5/16	11	11-7/16	47	6	9-1/2	70	84
D5-20P-42	D6-20P-42	42	51	8-7/8	9-3/8	30-3/4	45-15/16	45-5/8	5/16	11-1/16	11-1/2	53	7-1/2	9-1/2	86	100
D5-20P-48	D6-20P-48	48	57	9-1/4	9-3/4	36-3/4	51-9/16	51-3/16	5/16	11-11/16	12-1/8	59	7-1/2	9-1/2	98	115
D5-20P-54	D6-20P-54	54	63	9-5/16	9-13/16	42-1/2	57-9/16	57-3/16	3/8	11-3/4	12-3/16	65-1/2	9	11	110	128
D5-20P-60	D6-20P-60	60	69	9-5/16	9-13/16	48-1/2	63-9/16	63-3/16	3/8	11-3/4	12-3/16	71-1/2	9	11	118	138
D5-20P-72	D6-20P-72	72	81	9-5/16	9-13/16	60-1/2	75-9/16	75-3/16	3/8	11-3/4	12-3/16	83-1/2	9	11	136	159

Add "TTM", "DRY", "WET", "LOW" to the end of the part number to add application specific seals.

Belt Width (Reinforcing on 36" BW - 72" BW frame only).

Individual bracket weights are listed on "Return & Flat Brackets Styles" section. Brackets sold separately.

Also available in rubber cushion rollers. Designated by "PI". For impact roll only in the center use "PCI".

# CEMA D IDLERS

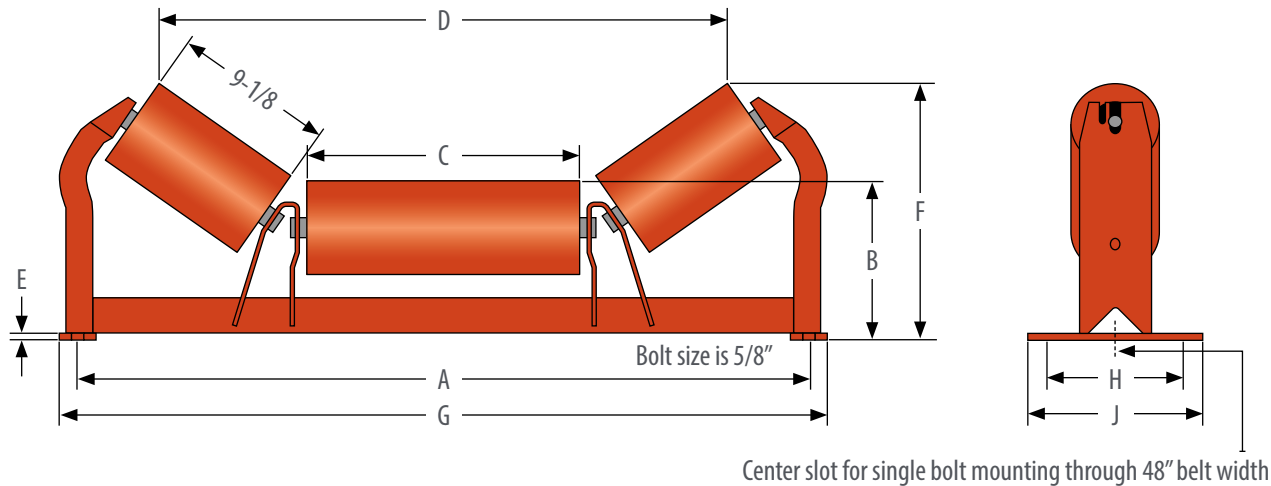

## TROUGHING IDLERS (UNEQUAL LENGTH ROLLERS): 5" AND 6" DIAMETER

	PART NUMBER		BW	A	B		D		E	F		G	H	J	WT (#)		
	5"	6"			5"	6"	5"	6"		5"	6"				5"	6"	
20°	D5-20U-30	D6-20U-30	30	39	8-1/2	9	15-1/16	33-1/2	33-3/16	5/16	11-11/16	12-1/8	41	6	9-1/2	63	76
	D5-20U-36	D6-20U-36	36	45	8-1/2	9	21-1/16	39-1/2	39-3/16	5/16	11-11/16	12-1/8	47	6	9-1/2	70	85
	D5-20U-42	D6-20U-42	42	51	8-7/8	9-3/8	26-1/2	45-3/16	44-3/4	5/16	12-5/16	12-3/4	53	7-1/2	9-1/2	86	101
	D5-20U-48	D6-20U-48	48	57	9-1/4	9-3/4	32-1/2	51-5/16	50-15/16	5/16	12-3/8	12-13/16	59	7-1/2	9-1/2	99	116
	D5-20U-54	D6-20U-54	54	63	9-5/16	9-13/16	38-1/16	57-5/16	56-15/16	3/8	12-7/16	12-7/8	65-1/2	9	11	110	128
	D5-20U-60	D6-20U-60	60	69	9-5/16	9-13/16	44-1/16	63-5/16	62-15/16	3/8	12-7/16	12-7/8	71-1/2	9	11	119	139
	D5-20U-72	D6-20U-72	72	81	9-5/16	9-13/16	56-1/16	75-5/16	74-15/16	3/8	12-7/16	12-7/8	83-1/2	9	11	136	160
35°	D5-35U-30	D6-35U-30	30	39	8-1/2	9	15	30-5/8	30-1/16	5/16	13-3/4	14-1/8	41	6	9-1/2	65	78
	D5-35U-36	D6-35U-36	36	45	8-1/2	9	21	36-5/8	36-1/16	5/16	12-3/4	14-1/8	47	6	9-1/2	72	87
	D5-35U-42	D6-35U-42	42	51	8-7/8	9-3/8	26-1/2	42-5/16	41-3/4	5/16	14-3/16	14-9/16	53	7-1/2	9-1/2	87	103
	D5-35U-48	D6-35U-48	48	57	9-1/4	9-3/4	32-1/2	48-1/4	47-11/16	5/16	14-1/2	14-15/16	59	7-1/2	9-1/2	100	118
	D5-35U-54	D6-35U-54	54	63	9-5/16	9-13/16	38-1/16	54-1/4	53-11/16	3/8	14-9/16	15	65-1/2	9	11	111	130
	D5-35U-60	D6-35U-60	60	69	9-5/16	9-13/16	44-1/16	60-1/4	59-11/16	3/8	14-9/16	15	71-1/2	9	11	120	141
	D5-35U-72	D6-35U-72	72	81	9-5/16	9-13/16	56-1/16	72-1/4	71-11/16	3/8	14-9/16	15	83-1/2	9	11	138	161
45°	D5-45U-30	D6-45U-30	30	39	8-1/2	9	15	28-3/4	28-1/16	5/16	15-1/16	16-3/8	41	6	9-1/2	67	79
	D5-45U-36	D6-45U-36	36	45	8-1/2	9	21	34-3/4	34-1/16	5/16	15-1/16	15-3/8	47	6	9-1/2	74	88
	D5-45U-42	D6-45U-42	42	51	8-7/8	9-3/8	26-1/2	39-1/2	33-13/16	5/16	15-9/16	15-7/8	53	7-1/2	9-1/2	89	104
	D5-45U-48	D6-45U-48	48	57	9-1/4	9-3/4	32-1/2	46-3/4	46-1/16	5/16	15-7/8	13-3/16	59	7-1/2	9-1/2	102	119
	D5-45U-54	D6-45U-54	54	63	9-5/16	9-13/16	38-1/16	52-3/4	52-1/16	3/8	15-15/16	16-1/4	65-1/2	9	11	113	132
	D5-45U-60	D6-45U-60	60	69	9-5/16	9-13/16	44-1/16	58-3/4	58-1/16	3/8	15-15/16	16-1/4	71-1/2	9	11	122	142
	D5-45U-72	D6-45U-72	72	81	9-5/16	9-13/16	56-1/16	70-3/4	70-1/16	3/8	15-15/16	16-1/4	83-1/2	9	11	140	163

Add "TTM", "DRY", "WET", "LOW" to the end of the part number to add application specific seals.

Belt Width (Reinforcing on 36" BW - 72" BW Impact Frame only).

Recommended bolt pattern, see "Return & Flat Brackets Styles" section for minimum and maximum dimensions.

Also available in rubber cushioned roller. Designated by "UI".

# DX IDLERS

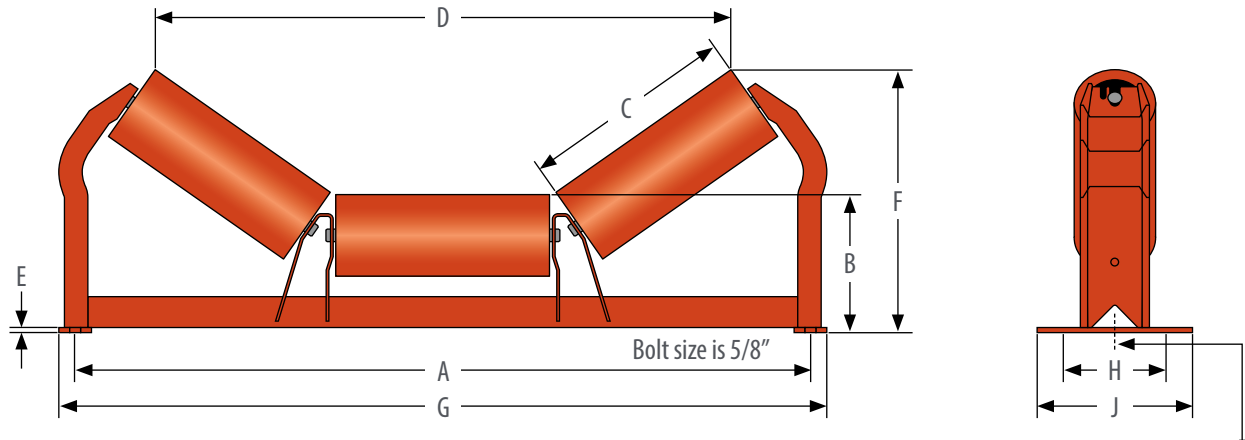

Center slot for single bolt mounting through 48" belt width

## TROUGHING IDLERS (EQUAL LENGTH ROLLERS): 5" AND 6" DIAMETER

	PART NUMBER		BW	A	B		C	D		E	F		G	H	J	WT (#)	
	5"	6"			5"	6"		5"	6"		5"	6"				5"	6"
20°	D5-20E-30-DX	D6-20E-30-DX	30	39	8-1/2	9	11-1/16	33-7/16	33-1/8	5/16	12-3/8	12-13/16	41	6	9-1/2	64	76
	D5-20E-36-DX	D6-20E-36-DX	36	45	8-1/2	9	13-1/16	39-3/16	38-7/8	5/16	13-1/16	13-1/2	47	6	9-1/2	71	86
	D5-20E-42-DX	D6-20E-42-DX	42	51	8-7/8	9-3/8	15-1/16	44-15/16	44-5/8	5/16	14-1/8	14-5/8	53	7-1/2	9-1/2	87	104
	D5-20E-48-DX	D6-20E-48-DX	48	57	9-1/4	9-3/4	17-1/16	51	50-11/16	5/16	14-7/8	15-5/16	59	7-1/2	9-1/2	101	119
	D5-20E-54-DX	D6-20E-54-DX	54	63	9-5/16	9-13/16	19-1/16	56-1/2	56-1/8	3/8	15-15/16	16-3/8	65-1/2	9	11	113	133
	D5-20E-60-DX	D6-20E-60-DX	60	69	9-5/16	9-13/16	21-1/16	62-1/4	61-7/8	3/8	16-5/8	17-1/16	71-1/2	9	11	122	144
	D5-20E-72-DX	D6-20E-72-DX	72	81	9-5/16	9-13/16	25-1/16	73-3/4	73-3/8	3/8	18	18-7/16	83-1/2	9	11	140	166
35°	D5-35E-30-DX	D6-35E-30-DX	30	39	8-1/2	9	11-1/16	30	29-7/16	5/16	14-15/16	15-3/8	41	6	9-1/2	66	78
	D5-35E-36-DX	D6-35E-36-DX	36	45	8-1/2	9	13-1/16	35-5/16	34-3/4	5/16	16-1/8	16-1/2	47	6	9-1/2	74	88
	D5-35E-42-DX	D6-35E-42-DX	42	51	8-7/8	9-3/8	15-1/16	40-9/16	40	5/16	17-5/8	18-1/16	53	7-1/2	9-1/2	90	107
	D5-35E-48-DX	D6-35E-48-DX	48	57	9-1/4	9-3/4	17-1/16	46-1/4	45-11/16	5/16	18-15/16	19-5/16	59	7-1/2	9-1/2	104	122
	D5-35E-54-DX	D6-35E-54-DX	54	63	9-5/16	9-13/16	19-1/16	51-1/8	50-9/16	3/8	20-3/8	20-3/4	65-1/2	9	11	117	137
	D5-35E-60-DX	D6-35E-60-DX	60	69	9-5/16	9-13/16	21-1/16	56-7/16	55-13/16	3/8	21-1/2	21-7/8	71-1/2	9	11	126	148
	D5-35E-72-DX	D6-35E-72-DX	72	81	9-5/16	9-13/16	25-1/16	66-15/16	66-3/8	3/8	23-13/16	24-3/16	83-1/2	9	11	145	171
45°	D5-45E-30-DX	D6-45E-30-DX	30	39	8-1/2	9	11-1/16	27-11/16	27	5/16	16-1/2	16-13/16	41	6	9-1/2	68	80
	D5-45E-36-DX	D6-45E-36-DX	36	45	8-1/2	9	13-1/16	32-1/2	31-3/16	5/16	17-15/16	18-1/4	47	6	9-1/2	76	90
	D5-45E-42-DX	D6-45E-42-DX	42	51	8-7/8	9-3/8	15-1/16	37-3/8	36-11/16	5/16	19-11/16	20-1/16	53	7-1/2	9-1/2	92	109
	D5-45E-48-DX	D6-45E-48-DX	48	57	9-1/4	9-3/4	17-1/16	42-9/16	41-7/8	5/16	21-5/16	21-5/8	59	7-1/2	9-1/2	106	125
	D5-45E-54-DX	D6-45E-54-DX	54	63	9-5/16	9-13/16	19-1/16	47	46-5/16	3/8	22-15/16	23-5/16	65-1/2	9	11	119	139
	D5-45E-60-DX	D6-45E-60-DX	60	69	9-5/16	9-13/16	21-1/16	51-7/8	51-3/16	3/8	24-3/8	24-11/16	71-1/2	9	11	129	151
	D5-45E-72-DX	D6-45E-72-DX	72	81	9-5/16	9-13/16	25-1/16	61-1/2	60-13/16	3/8	27-3/16	27-9/16	83-1/2	9	11	148	174

# DX IDLERS

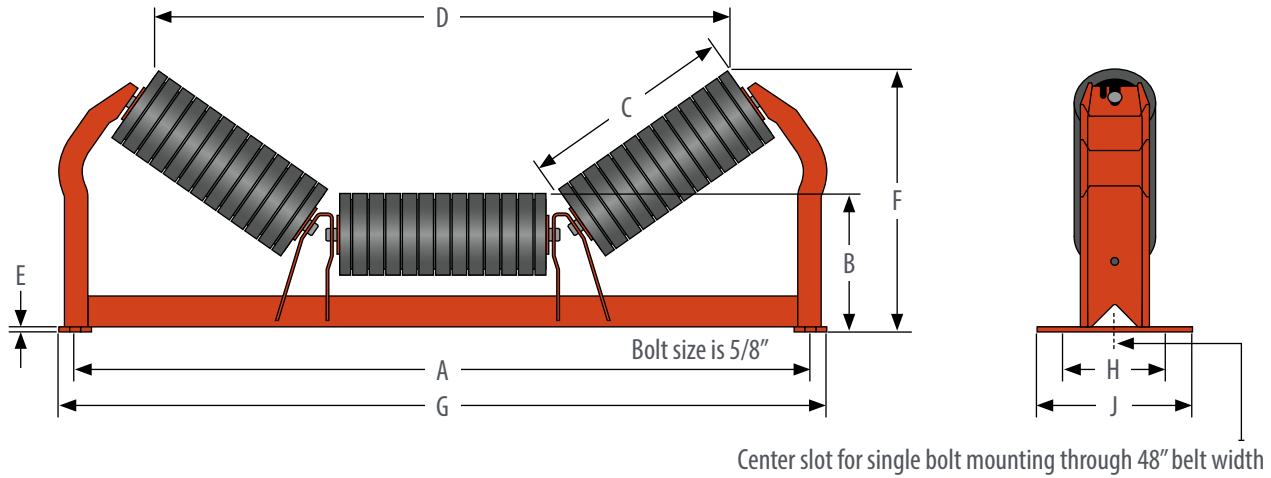

## RUBBER CUSHION IMPACT TROUGHING IDLER: 5" AND 6" DIAMETER

	PART NUMBER		BW	A		B		C	D		E	F		G	H	J	WT (#)	
	5"	6"		5"	6"	5"	6"		5"	6"		5"	6"				5"	6"
20°	D5-20EI-30-DX	D6-20EI-30-DX	30	39	8-1/2	9	11-1/8	32-1/8	31-3/4	5/16	12-3/16	12-11/16	41	6	9-1/2	74	82	
	D5-20EI-36-DX	D6-20EI-36-DX	36	45	8-1/2	9	13-1/8	37-7/8	37-1/2	5/16	12-7/8	13-3/8	47	6	9-1/2	92	94	
	D5-20EI-42-DX	D6-20EI-42-DX	42	51	8-7/8	9-3/8	15-1/8	43-5/8	43-1/4	5/16	13-15/16	14-7/16	53	7-1/2	9-1/2	112	123	
	D5-20EI-48-DX	D6-20EI-48-DX	48	57	9-1/4	9-3/4	17-1/8	49-11/16	49-5/16	5/16	14-11/16	15-3/16	59	7-1/2	9-1/2	129	141	
	D5-20EI-54-DX	D6-20EI-54-DX	54	63	9-5/16	9-13/16	19-1/8	55-1/8	54-3/4	3/8	15-3/4	16-3/16	65-1/2	9	11	146	160	
	D5-20EI-60-DX	D6-20EI-60-DX	60	69	9-5/16	9-13/16	21-1/8	60-7/8	60-1/2	3/8	16-7/16	16-7/8	71-1/2	9	11	159	175	
	D5-20EI-72-DX	D6-20EI-72-DX	72	81	9-5/16	9-13/16	25-1/8	72-3/8	72	3/8	17-13/16	18-1/4	83-1/2	9	11	183	202	
35°	D5-35EI-30-DX	D6-35EI-30-DX	30	39	8-1/2	9	11-1/8	28-13/16	28-3/16	5/16	14-5/8	15-1/16	41	6	9-1/2	76	85	
	D5-35EI-36-DX	D6-35EI-36-DX	36	45	8-1/2	9	13-1/8	34-1/16	33-1/2	5/16	15-13/16	16-3/16	47	6	9-1/2	95	97	
	D5-35EI-42-DX	D6-35EI-42-DX	42	51	8-7/8	9-3/8	15-1/8	39-5/16	38-3/4	5/16	17-5/16	17-3/4	53	7-1/2	9-1/2	116	127	
	D5-35EI-48-DX	D6-35EI-48-DX	48	57	9-1/4	9-3/4	17-1/8	44-15/16	44-7/16	5/16	18-5/8	19	59	7-1/2	9-1/2	132	145	
	D5-35EI-54-DX	D6-35EI-54-DX	54	63	9-5/16	9-13/16	19-1/8	49-7/8	49-5/16	3/8	20	20-7/16	65-1/2	9	11	150	165	
	D5-35EI-60-DX	D6-35EI-60-DX	60	69	9-5/16	9-13/16	21-1/8	55-1/8	54-9/16	3/8	21-3/16	21-9/16	71-1/2	9	11	163	179	
	D5-35EI-72-DX	D6-35EI-72-DX	72	81	9-5/16	9-13/16	25-1/8	65-11/16	65-1/8	3/8	23-1/2	23-7/8	83-1/2	9	11	188	207	
45°	D5-45EI-30-DX	D6-45EI-30-DX	30	39	8-1/2	9	11-1/8	26-9/16	25-7/8	5/16	16-1/16	16-7/16	41	6	9-1/2	78	86	
	D5-45EI-36-DX	D6-45EI-36-DX	36	45	8-1/2	9	13-1/8	31-7/16	30-11/16	5/16	17-1/2	17-7/16	47	6	9-1/2	97	99	
	D5-45EI-42-DX	D6-45EI-42-DX	42	51	8-7/8	9-3/8	15-1/8	36-3/16	35-1/2	5/16	19-5/16	16-5/8	53	7-1/2	9-1/2	118	129	
	D5-45EI-48-DX	D6-45EI-48-DX	48	57	9-1/4	9-3/4	17-1/8	41-7/16	40-3/4	5/16	20-15/16	21-1/4	59	7-1/2	9-1/2	135	148	
	D5-45EI-54-DX	D6-45EI-54-DX	54	63	9-5/16	9-13/16	19-1/8	45-7/8	45-3/16	3/8	22-9/16	22-7/8	65-1/2	9	11	152	167	
	D5-45EI-60-DX	D6-45EI-60-DX	60	69	9-5/16	9-13/16	21-1/8	50-11/16	50	3/8	23-15/16	24-5/16	71-1/2	9	11	166	183	
	D5-45EI-72-DX	D6-45EI-72-DX	72	81	9-5/16	9-13/16	25-1/8	60-3/8	59-5/8	3/8	26-13/16	27-1/8	83-1/2	9	11	191	211	

# DX IDLERS

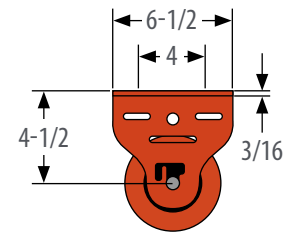
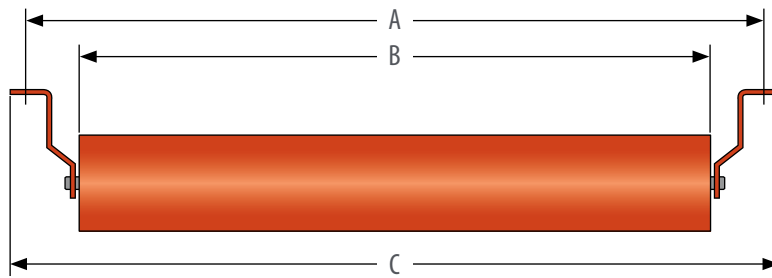

SLOTTED FOR 1/2" Ø BOLT

## RETURN IDLERS: 5" AND 6" DIAMETER

PART NUMBER		BW	A	B	C	WT (#)	
5"	6"					5"	6"
D5-RET-18-DX	D6-RET-18-DX	18	27	21-3/8	28-7/16	25	33
D5-RET-20-DX	D6-RET-20-DX	20	29	23-3/8	30-7/16	27	34
D5-RET-24-DX	D6-RET-24-DX	24	33	27-3/8	34-7/16	30	40
D5-RET-30-DX	D6-RET-30-DX	30	39	33-3/8	40-7/16	36	47
D5-RET-36-DX	D6-RET-36-DX	36	45	39-3/8	46-7/16	41	54
D5-RET-42-DX	D6-RET-42-DX	42	51	45-3/8	52-7/16	46	61
D5-RET-48-DX	D6-RET-48-DX	48	57	51-3/8	58-7/16	51	68
D5-RET-54-DX	D6-RET-54-DX	54	63	57-3/8	64-7/16	56	76
D5-RET-60-DX	D6-RET-60-DX	60	69	63-3/8	70-7/16	61	83
D5-RET-72-DX	D6-RET-72-DX	72	81	75-3/8	82-7/16	72	97

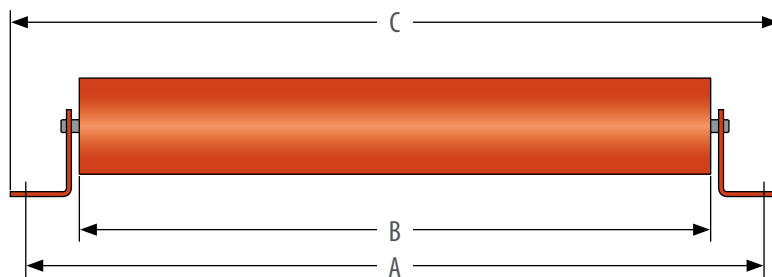

SLOTTED FOR 1/2" Ø BOLT

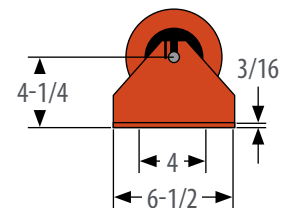

## FLAT IDLERS: 5" AND 6" DIAMETER

PART NUMBER		BW	A	B	C	WT (#)	
5"	6"					5"	6"
D5-RET-18-DX	D6-RET-18-DX	18	27	21-3/8	28-15/16	28	37
D5-RET-20-DX	D6-RET-20-DX	20	29	23-3/8	30-15/16	30	37
D5-RET-24-DX	D6-RET-24-DX	24	33	27-3/8	34-15/16	33	43
D5-RET-30-DX	D6-RET-30-DX	30	39	33-3/8	40-15/16	38	50
D5-RET-36-DX	D6-RET-36-DX	36	45	39-3/8	46-15/16	43	57
D5-RET-42-DX	D6-RET-42-DX	42	51	45-3/8	52-15/16	49	64
D5-RET-48-DX	D6-RET-48-DX	48	57	51-3/8	58-15/16	54	71
D5-RET-54-DX	D6-RET-54-DX	54	63	57-3/8	64-15/16	59	78
D5-RET-60-DX	D6-RET-60-DX	60	69	63-3/8	70-15/16	64	85
D5-RET-72-DX	D6-RET-72-DX	72	81	75-3/8	82-15/16	74	99

Individual bracket weights are listed on "Return & Flat Brackets Styles" section. Brackets sold separately.

# DX IDLERS

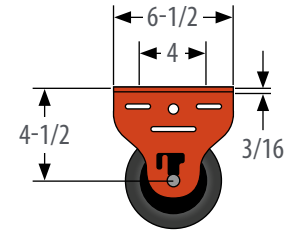
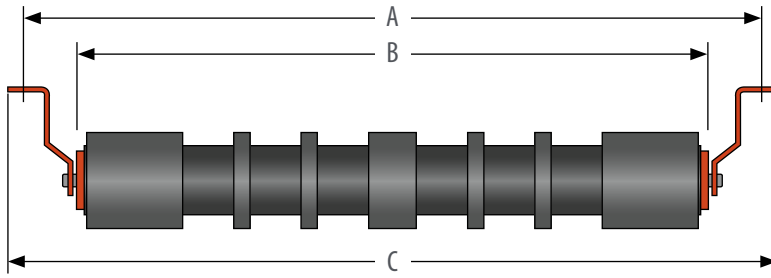

## RUBBER CUSHION RETURN IDLERS: 5" AND 6" DIAMETER

PART NUMBERS		BW	A	B	C	WT (#)	
5"	6"					5"	6"
D5-RETI-18-DX	D6-RETI-18-DX	18	27	21-7/16	28-7/16	31	34
D5-RETI-20-DX	D6-RETI-20-DX	20	29	23-7/16	30-7/16	34	37
D5-RETI-24-DX	D6-RETI-24-DX	24	33	27-7/16	34-7/16	38	42
D5-RETI-30-DX	D6-RETI-30-DX	30	39	33-7/16	40-7/16	45	49
D5-RETI-36-DX	D6-RETI-36-DX	36	45	39-7/16	46-7/16	52	57
D5-RETI-42-DX	D6-RETI-42-DX	42	51	45-7/16	52-7/16	59	63
D5-RETI-48-DX	D6-RETI-48-DX	48	57	51-7/16	58-7/16	65	70
D5-RETI-54-DX	D6-RETI-54-DX	54	63	57-7/16	64-7/16	72	77
D5-RETI-60-DX	D6-RETI-60-DX	60	69	63-7/16	70-7/16	79	85
D5-RETI-72-DX	D6-RETI-72-DX	72	81	75-7/16	82-7/16	93	99

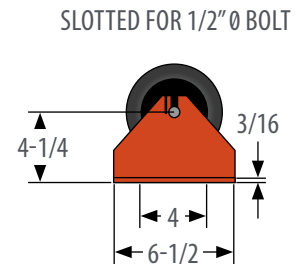
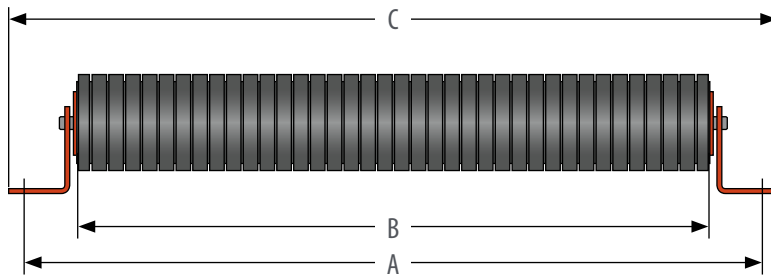

## RUBBER CUSHION FLAT IDLERS: 5" AND 6" DIAMETER

PART NUMBERS		BW	A	B	C	WT(#)	
5"	6"					5"	6"
D5-FLTI-24-DX	D6-FLTI-24-DX	24	33	27-7/16	34-15/16	45	52
D5-FLTI-30-DX	D6-FLTI-30-DX	30	39	33-7/16	40-15/16	53	62
D5-FLTI-36-DX	D6-FLTI-36-DX	36	45	39-7/16	46-15/16	61	71
D5-FLTI-42-DX	D6-FLTI-42-DX	42	51	45-7/16	52-15/16	69	81
D5-FLTI-48-DX	D6-FLTI-48-DX	48	57	51-7/16	58-15/16	78	92
D5-FLTI-54-DX	D6-FLTI-54-DX	54	63	57-7/16	64-15/16	86	101
D5-FLTI-60-DX	D6-FLTI-60-DX	60	69	63-7/16	70-15/16	94	111
D5-FLTI-72-DX	D6-FLTI-72-DX	72	81	75-7/16	82-15/16	111	131

Individual bracket weights are listed on "Return & Flat Brackets Styles" section. Brackets sold separately.



# DX IDLERS

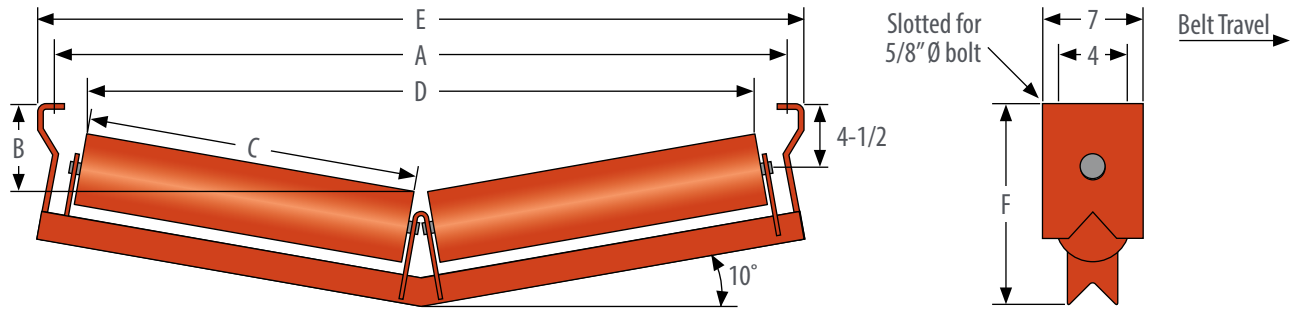

For wider base use next size larger belt width. Also available in 15°.

## V-RETURN IDLER: 5" AND 6" DIAMETER

PART NUMBERS		BW	A	B		C	D		E	F	WT (#)	
5"	6"			5"	6"		5"	6"			5"	6"
D5-10RETV-30-DX	D6-10RETV-30-DX	30	39	4-7/8	4-3/8	17	34-5/16	33-7/8	41-1/8	12-7/8	64	76
D5-10RETV-36-DX	D6-10RETV-36-DX	36	45	5-7/16	4-15/16	20-1/2	41-1/16	40-5/8	47-1/8	13-3/8	71	86
D5-10RETV-42-DX	D6-10RETV-42-DX	42	51	5-15/16	5-7/16	23-3/8	46-11/16	46-1/4	53-1/8	14	78	92
D5-10RETV-48-DX	D6-10RETV-48-DX	48	57	6-7/16	6	26-1/2	53	52-9/16	59-1/8	14-1/2	85	103
D5-10RETV-54-DX	D6-10RETV-54-DX	54	63	7	6-1/2	29-1/4	58-5/16	57-7/8	65-1/8	15-3/8	107	127
D5-10RETV-60-DX	D6-10RETV-60-DX	60	69	7-1/2	7-1/16	32-1/2	64-13/16	64-3/8	71-1/8	15-7/8	116	138
D5-10RETV-66-DX	D6-10RETV-66-DX	66	75	8-1/16	7-9/16	35-3/4	71-1/8	70-11/16	77-1/8	16-3/8	125	149
D5-10RETV-72-DX	D6-10RETV-72-DX	72	81	8-9/16	8-1/16	38	75-5/8	75-3/16	83-1/8	17	132	157
D5-10RETV-78-DX	D6-10RETV-78-DX	78	87	9-1/8	8-5/8	41-1/4	82	81-9/16	89-1/8	17-1/2	140	164

# CEMA E IDLERS

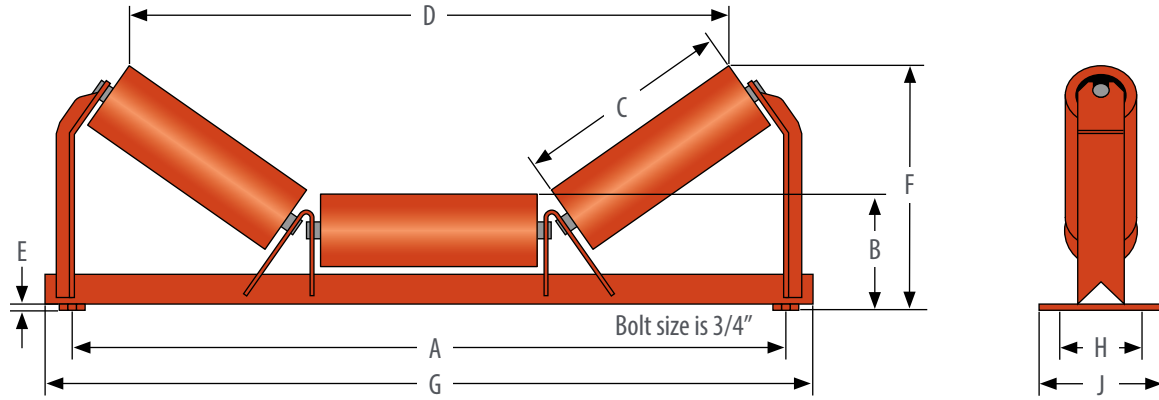

## TROUGHING IDLER (EQUAL LENGTH ROLLERS): 6" AND 7" DIAMETER

	PART NUMBER		BW	A	B		D		E	F		G	H	J	WT (#)		
	6"	7"			6"	7"	6"	7"		6"	7"				6"	7"	
20°	E6-20E-36	E7-20E-36	36	45	10-3/4	11-1/4	12-3/4	39-13/16	39-1/2	1/2	15-3/8	15-13/16	49	7-1/2	12	158	169
	E6-20E-42	E7-20E-42	42	51	10-3/4	11-1/4	14-3/4	45-5/8	45-1/4	1/2	16-1/16	16-1/2	55	7-1/2	12	174	187
	E6-20E-48	E7-20E-48	48	57	10-3/4	11-1/4	17-1/2	53-1/2	53-3/16	1/2	17	17-7/16	63	7-1/2	12	197	212
	E6-20E-54	E7-20E-54	54	63	10-3/4	11-1/4	19-1/2	59-1/4	58-15/16	1/2	17-11/16	18-1/8	68-1/2	7-1/2	12	213	221
	E6-20E-60	E7-20E-60	60	69	10-3/4	11-1/4	21-1/2	65-1/16	64-11/16	1/2	18-3/8	18-13/16	74-1/4	7-1/2	12	229	247
	E6-20E-72	E7-20E-72	72	81	11-1/2	12	25-1/2	76-9/16	76-3/16	1/2	20-1/2	20-15/16	86	7-1/2	12	264	283
	E6-20E-84	E7-20E-84	84	93	11-3/4	12-1/4	29-1/2	88-1/16	87-3/4	1/2	22-1/16	22-9/16	97-1/4	9	14	298	321
	E6-20E-96	E7-20E-96	96	105	11-3/4	12-1/4	33-1/2	99-9/16	99-1/4	1/2	23-7/16	23-15/16	109	9	14	331	357
35°	E6-35E-36	E7-35E-36	36	45	10-3/4	11-1/4	12-3/4	35-13/16	35-1/4	1/2	18-1/4	18-11/16	49	7-1/2	12	163	174
	E6-35E-42	E7-35E-42	42	51	10-3/4	11-1/4	14-3/4	41-1/16	40-1/2	1/2	19-7/16	19-13/16	55	7-1/2	12	180	192
	E6-35E-48	E7-35E-48	48	57	10-3/4	11-1/4	17-1/2	48-5/16	47-3/4	1/2	21	21-7/16	63	7-1/2	12	203	217
	E6-35E-54	E7-35E-54	54	63	10-3/4	11-1/4	19-1/2	53-9/16	53-1/16	1/2	22-1/8	22-9/16	68-1/2	7-1/2	12	220	235
	E6-35E-60	E7-35E-60	60	69	10-3/4	11-1/4	21-1/2	58-7/8	58-5/16	1/2	23-5/16	23-11/16	74-1/4	7-1/2	12	236	253
	E6-35E-72	E7-35E-72	72	81	11-1/2	11-15/16	25-1/2	69-7/16	68-7/8	1/2	26-5/16	26-3/4	86	7-1/2	12	273	299
	E6-35E-84	E7-35E-84	84	93	11-3/4	12-3/16	29-1/2	79-15/16	79-7/16	1/2	28-15/16	29-5/16	97-1/2	9	14	307	339
	E6-35E-96	E7-35E-96	96	105	11-3/4	12-3/16	33-1/2	90-1/2	89-15/16	1/2	31-3/16	31-9/16	109	9	14	342	376
45°	E6-45E-36	E7-45E-36	36	45	10-3/4	11-1/4	12-3/4	32-5/16	31-5/8	1/2	19-15/16	20-5/16	49	7-1/2	12	167	179
	E6-45E-42	E7-45E-42	42	51	10-3/4	11-1/4	14-3/4	37-1/8	36-7/16	1/2	21-3/8	21-11/16	55	7-1/2	12	184	198
	E6-45E-48	E7-45E-48	48	57	10-3/4	11-1/4	17-1/2	43-3/4	43-1/16	1/2	23-5/16	23-5/8	63	7-1/2	12	208	224
	E6-45E-54	E7-45E-54	54	63	10-3/4	11-1/4	19-1/2	48-5/8	47-15/16	1/2	24-11/16	26-1/16	68-1/2	7-1/2	12	225	242
	E6-45E-60	E7-45E-60	60	69	10-3/4	11-1/4	21-1/2	53-7/16	52-3/4	1/2	26-1/8	26-1/2	74-1/4	7-1/2	12	242	261
	E6-45E-72	E7-45E-72	72	81	11-1/2	11-15/16	25-1/2	63-1/16	62-3/8	1/2	29-11/16	30-1/16	86	7-1/2	12	279	306
	E6-45E-84	E7-45E-84	84	93	11-3/4	12-3/16	29-1/2	72-3/4	72-1/16	1/2	32-3/4	33-1/8	97-1/4	9	14	315	346
	E6-45E-96	E7-45E-96	96	105	11-3/4	12-3/16	33-1/2	82-7/16	81-3/4	1/2	35-5/8	35-15/16	109	9	14	350	384

# CEMA E IDLERS

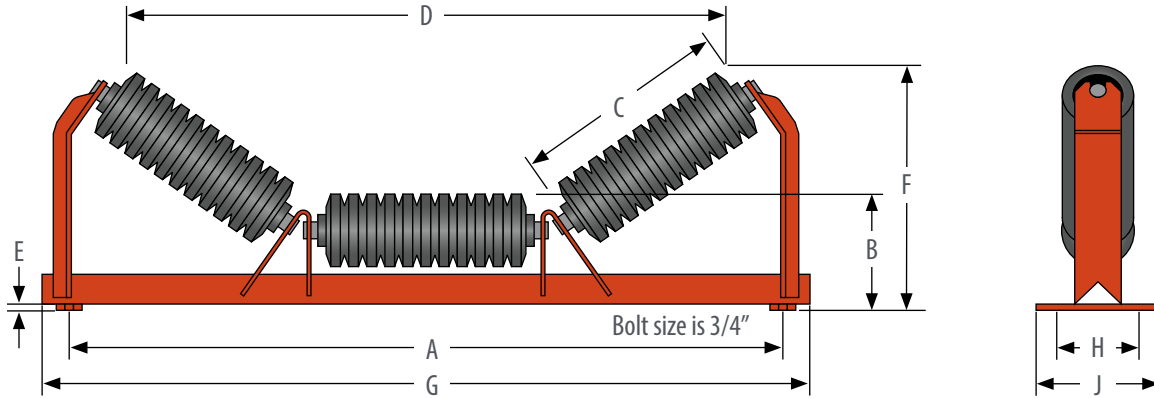

## RUBBER CUSHION IMPACT TROUGHING IDLERS: 6" AND 7" DIAMETER

	PART NUMBER		BW	A	B		C	D		E	F		G	H	J	WT (#)	
	6"	7"			6"	7"		6"	7"		6"	7"				6"	7"
20°	E6-20EI-36	E7-20EI-36	36	45	10-3/4	11-1/4	13-1/8	37-3/4	37-3/8	1/2	15-1/16	15-1/2	49	7-1/2	12	145	158
	E6-20EI-42	E7-20EI-42	42	51	10-3/4	11-1/4	15-1/8	43-1/2	43-1/8	1/2	15-3/4	16-3/16	55	7-1/2	12	161	177
	E6-20EI-48	E7-20EI-48	48	57	10-3/4	11-1/4	17-7/8	51-7/16	51-1/16	1/2	16-11/16	17-1/8	63	7-1/2	12	184	205
	E6-20EI-54	E7-20EI-54	54	63	10-3/4	11-1/4	19-7/8	57-3/16	56-7/8	1/2	17-3/8	17-13/16	68-1/2	7-1/2	12	200	223
	E6-20EI-60	E7-20EI-60	60	69	10-3/4	11-1/4	21-7/8	62-15/16	62-5/8	1/2	18-1/16	18-1/2	74-1/4	7-1/2	12	216	241
	E6-20EI-72	E7-20EI-72	72	81	11-1/2	12	25-7/8	74-7/16	74-1/8	1/2	20-3/16	20-5/8	86	7-1/2	12	250	280
	E6-20EI-84	E7-20EI-84	84	93	11-3/4	12-1/4	29-7/8	85-15/16	85-5/8	1/2	21-13/16	22-1/4	94-1/4	9	14	283	318
	E6-20EI-96	E7-20EI-96	96	105	11-3/4	12-1/4	33-7/8	97-1/2	97-3/16	1/2	23-1/8	23-5/8	109	9	14	315	355
35°	E6-35EI-36	E7-35EI-36	36	45	10-3/4	11-1/4	13-1/8	33-15/16	33-5/16	1/2	17-3/4	18-3/16	49	7-1/2	12	150	164
	E6-35EI-42	E7-35EI-42	42	51	10-3/4	11-1/4	15-1/8	39-1/8	38-9/16	1/2	18-15/16	19-5/16	55	7-1/2	12	167	183
	E6-35EI-48	E7-35EI-48	48	57	10-3/4	11-1/4	17-7/8	46-3/8	45-13/16	1/2	20-1/2	20-15/16	63	7-1/2	12	191	211
	E6-35EI-54	E7-35EI-54	54	63	10-3/4	11-1/4	19-7/8	51-11/16	51-1/8	1/2	21-5/8	22-1/16	68-1/2	7-1/2	12	207	230
	E6-35EI-60	E7-35EI-60	60	69	10-3/4	11-1/4	21-7/8	56-15/16	56-3/8	1/2	22-13/16	23-3/16	74-1/4	7-1/2	12	223	249
	E6-35EI-72	E7-35EI-72	72	81	11-1/2	12	25-7/8	67-1/2	66-15/16	1/2	25-13/16	26-1/4	86	7-1/2	12	258	288
	E6-35EI-84	E7-35EI-84	84	93	11-3/4	12-1/4	29-7/8	78-1/16	77-7/16	1/2	28-3/8	28-3/4	97-1/4	9	14	293	328
	E6-35EI-96	E7-35EI-96	96	105	11-3/4	12-1/4	33-7/8	88-5/8	88-1/16	1/2	30-11/16	31-1/16	109	9	14	326	366
45°	E6-45EI-36	E7-45EI-36	36	45	10-3/4	11-1/4	13-1/8	30-5/8	29-15/16	1/2	19-1/4	19-5/8	49	7-1/2	12	154	168
	E6-45EI-42	E7-45EI-42	42	51	10-3/4	11-1/4	15-1/8	35-3/8	34-11/16	1/2	20-11/16	21-1/16	55	7-1/2	12	171	187
	E6-45EI-48	E7-45EI-48	48	57	10-3/4	11-1/4	17-7/8	42-1/16	41-5/16	1/2	22-5/8	23	63	7-1/2	12	196	216
	E6-45EI-54	E7-45EI-54	54	63	10-3/4	11-1/4	19-7/8	46-15/16	46-3/16	1/2	24-1/16	24-7/16	68-1/2	7-1/2	12	212	235
	E6-45EI-60	E7-45EI-60	60	69	10-3/4	11-1/4	21-7/8	51-11/16	51	1/2	25-1/2	25-13/16	74-1/4	7-1/2	12	229	254
	E6-45EI-72	E7-45EI-72	72	81	11-1/2	12	25-7/8	61-3/8	60-5/8	1/2	29-1/16	29-3/8	86	7-1/2	12	265	295
	E6-45EI-84	E7-45EI-84	84	93	11-3/4	12-1/4	29-7/8	71	70-5/16	1/2	32-1/8	32-7/16	97-1/2	9	14	300	335
	E6-45EI-96	E7-45EI-96	96	105	11-3/4	12-1/4	33-7/8	80-11/16	80	1/2	34-15/16	35-5/16	109	9	14	334	374

Add "TTM", "DRY", "WET", "LOW" to the end of the part number to add application specific seals.

# CEMA E IDLERS

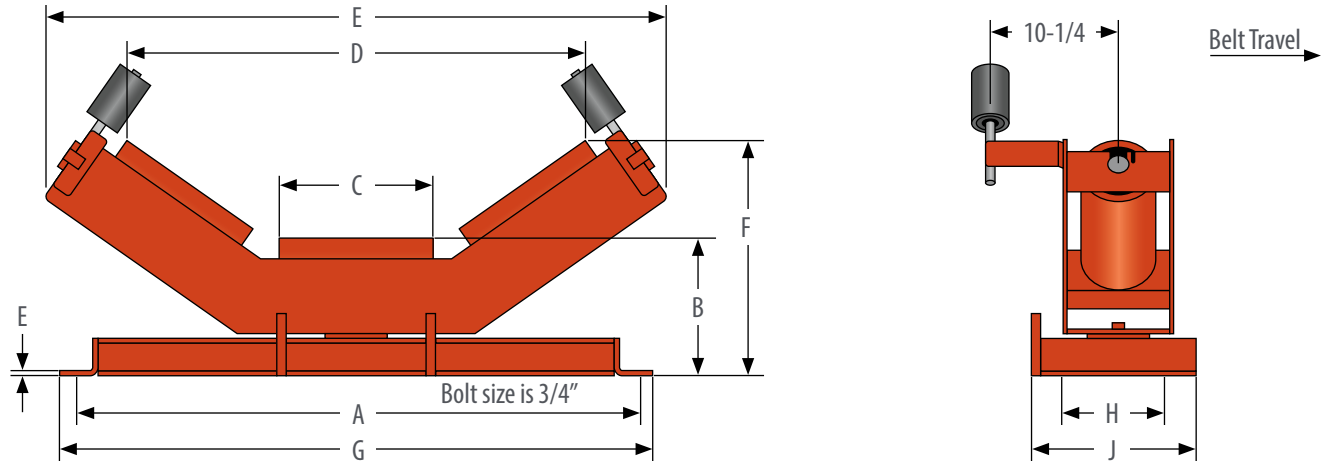

## SELF-ALIGNING TROUGHING IDLERS: 6" AND 7" DIAMETER

	PART NUMBER		BW	B		C	D		E	F		G	H	J	WT (#)		
	6"	7"		6"	7"		6"	7"		6"	7"				6"	7"	
20°	E6-20EA-36	E7-20EA-36	36	45	11-1/16	11-9/16	12-3/4	42-5/8	42-1/4	52-15/16	15-13/16	16-5/16	47-1/2	9-1/2	12-1/2	259	270
	E6-20EA-42	E7-20EA-42	42	51	11-1/16	11-9/16	14-3/4	48-3/8	48	58-3/4	16-1/2	17	53-1/2	9-1/2	12-1/2	284	296
	E6-20EA-48	E7-20EA-48	48	57	11-1/16	11-9/16	17-1/2	56-5/16	55-15/16	66-5/8	17-7/16	17-15/16	59-1/2	9-1/2	12-1/2	316	330
	E6-20EA-54	E7-20EA-54	54	63	11-1/16	11-9/16	19-1/2	61-1/16	61-11/16	72-3/8	18-1/8	18-5/8	65-1/2	9-1/2	12-1/2	341	357
	E6-20EA-60	E7-20EA-60	60	69	11-1/16	11-9/16	21-1/2	67-13/16	67-7/16	78-3/16	18-13/16	19-5/16	71-1/2	9-1/2	12-1/2	366	383
	E6-20EA-72	E7-20EA-72	72	81	12-1/16	12-9/16	25-1/2	79-5/16	79	89-11/16	21-3/16	21-11/16	83-1/2	9-1/2	12-1/2	417	436
	E6-20EA-84	E7-20EA-84	84	93	12-1/16	12-9/16	29-1/2	90-13/16	90-1/2	101-3/16	22-9/16	23	95-1/2	12	15	495	517
	E6-20EA-96	E7-20EA-96	96	105	12-1/16	12-9/16	33-1/2	102-3/8	102	112-11/16	23-15/16	24-3/8	107-1/2	12	15	548	573
	E6-35EA-36	E7-35EA-36	36	45	11-1/16	11-9/16	12-3/4	36-3/4	36-3/16	49-7/8	18-15/16	19-5/8	47-1/2	9-1/2	12-1/2	261	272
E6-35EA-42	E7-35EA-42	42	51	11-1/16	11-9/16	14-3/4	42	41-7/16	55-1/8	20-1/16	20-1/2	53-1/2	9-1/2	12-1/2	286	299	
E6-35EA-48	E7-35EA-48	48	57	11-1/16	11-9/16	17-1/2	49-1/4	48-11/16	62-3/8	21-5/8	22-1/16	59-1/2	9-1/2	12-1/2	318	332	
E6-35EA-54	E7-35EA-54	54	63	11-1/16	11-9/16	19-1/2	54-9/16	54	67-5/8	22-13/16	23-3/16	65-1/2	9-1/2	12-1/2	343	359	
E6-35EA-60	E7-35EA-60	60	69	11-1/16	11-9/16	21-1/2	59-13/16	59-1/4	72-15/16	23-15/16	24-3/8	71-1/2	9-1/2	12-1/2	369	386	
E6-35EA-72	E7-35EA-72	72	81	12-1/16	12-9/16	25-1/2	70-3/8	69-13/16	83-1/2	27-1/4	27-5/8	83-1/2	9-1/2	12-1/2	419	439	
E6-35EA-84	E7-35EA-84	84	93	12-1/16	12-9/16	29-1/2	80-15/16	80-3/8	94-1/16	29-1/2	29-15/16	95-1/2	12	15	498	520	
E6-35EA-96	E7-35EA-96	96	105	12-1/16	12-9/16	33-1/2	91-1/2	90-15/16	104-9/16	31-13/16	32-1/4	107-1/2	12	15	552	577	
35°	E6-45EA-36	E7-45EA-36	36	45	11-1/16	11-9/16	12-3/4	33-5/16	32-5/8	47-1/8	20-5/8	21	47-1/2	9-1/2	12-1/2	259	270
	E6-45EA-42	E7-45EA-42	42	51	11-1/16	11-9/16	14-3/4	37-1/16	37-7/16	51-15/16	22-1/16	22-3/8	53-1/2	9-1/2	12-1/2	284	296
	E6-45EA-48	E7-45EA-48	48	57	11-1/16	11-9/16	17-1/2	44-13/16	44-1/16	58-9/16	24	24-5/16	59-1/2	9-1/2	12-1/2	315	330
	E6-45EA-54	E7-45EA-54	54	63	11-1/16	11-9/16	19-1/2	49-5/8	48-15/16	63-7/16	25-3/8	25-3/4	65-1/2	9-1/2	12-1/2	340	356
	E6-45EA-60	E7-45EA-60	60	69	11-1/16	11-9/16	21-1/2	54-7/16	53-3/4	68-1/4	26-13/16	27-3/16	71-1/2	9-1/2	12-1/2	365	382
	E6-45EA-72	E7-45EA-72	72	81	12-1/16	12-9/16	25-1/2	64-1/8	63-3/8	77-7/8	30-1/16	31	83-1/2	9-1/2	12-1/2	415	435
	E6-45EA-84	E7-45EA-84	84	93	12-1/16	12-9/16	29-1/2	73-3/4	73-1/16	87-9/16	33-1/2	33-13/16	95-1/2	12	15	493	515
	E6-45EA-96	E7-45EA-96	96	105	12-1/16	12-9/16	33-1/2	83-7/16	82-11/16	97-3/16	36-5/16	36-11/16	107-1/2	12	15	546	571

Add "TTM", "DRY", "WET", "LOW" to the end of the part number to add application specific seals.

# CEMA E IDLERS

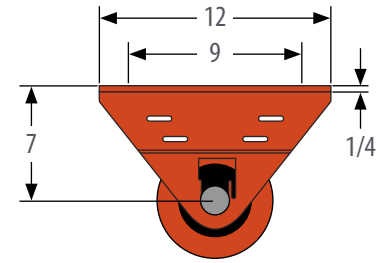
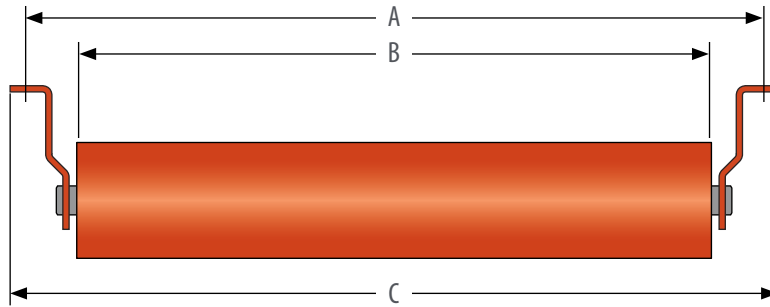

SLOTTED FOR 3/4" Ø BOLT

## RETURN IDLERS: 6" AND 7" DIAMETER

PART NUMBER		BW	A	B	C	WT (#)	
6"	7"					6"	7"
E6-RET-30	E7-RET-30	30	39	33	42	85	93
E6-RET-36	E7-RET-36	36	45	39	48	97	106
E6-RET-42	E7-RET-42	42	51	45	54	108	119
E6-RET-48	E7-RET-48	48	57	51	60	120	132
E6-RET-54	E7-RET-54	54	63	57	66	132	145
E6-RET-60	E7-RET-60	60	69	63	72	144	158
E6-RET-72	E7-RET-72	72	81	75	84	167	184
E6-RET-84	E7-RET-84	84	93	87	96	190	211
E6-RET-96	E7-RET-96	96	105	99	108	214	237

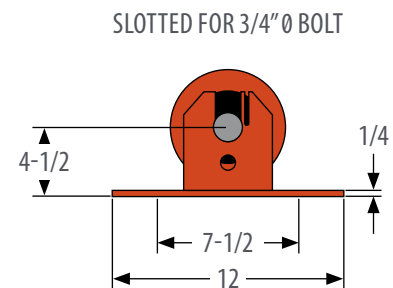
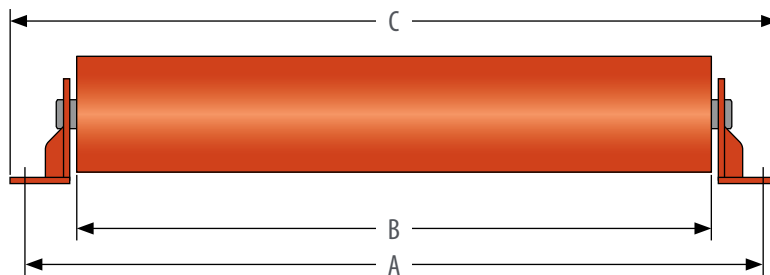

SLOTTED FOR 3/4" Ø BOLT

## FLAT IDLERS: 6" AND 7" DIAMETER

PART NUMBER		BW	A	B	C	WT (#)	
6"	7"					6"	7"
E6-RET-30	E7-RET-30	30	39	33	41-1/2	86	95
E6-RET-36	E7-RET-36	36	45	39	47-1/2	98	108
E6-RET-42	E7-RET-42	42	51	45	53-1/2	110	121
E6-RET-48	E7-RET-48	48	57	51	59-1/2	122	134
E6-RET-54	E7-RET-54	54	63	57	65-1/2	133	147
E6-RET-60	E7-RET-60	60	69	63	71-1/2	145	160
E6-RET-72	E7-RET-72	72	81	75	83-1/2	168	186
E6-RET-84	E7-RET-84	84	93	87	95-1/2	192	212
E6-RET-96	E7-RET-96	96	105	99	107-1/2	215	238

Add "TTM", "DRY", "WET", "LOW" to the end of the part number to add application specific seals.

Individual bracket weights are listed on "Return & Flat Brackets Styles" section. Brackets sold separately.

# CEMA E IDLERS

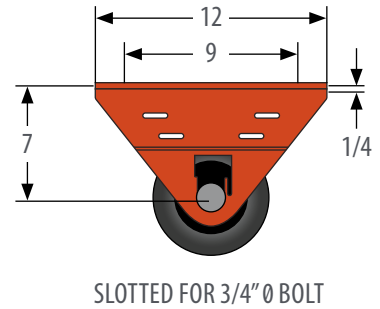
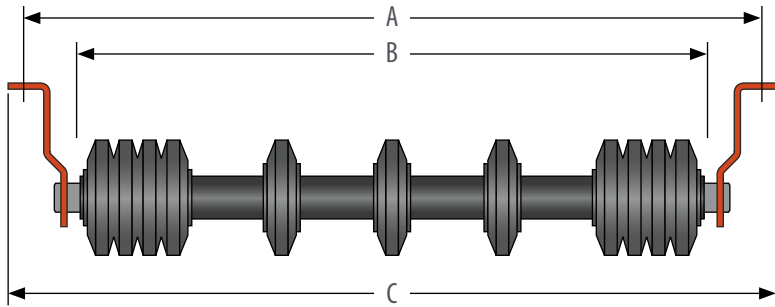

## RUBBER CUSHION RETURN IDLERS: 6" AND 7" DIAMETER

PART NUMBER		BW	A	B	C	WT (#)	
6"	7"					6"	7"
E6-RETI-36	E7-RETI-36	36	45	39	48	87	93
E6-RETI-42	E7-RETI-42	42	51	45	54	97	104
E6-RETI-48	E7-RETI-48	48	57	51	60	108	115
E6-RETI-54	E7-RETI-54	54	63	57	66	117	124
E6-RETI-60	E7-RETI-60	60	69	63	72	127	135
E6-RETI-72	E7-RETI-72	72	81	75	84	147	155
E6-RETI-84	E7-RETI-84	84	93	87	96	169	179
E6-RETI-96	E7-RETI-96	96	105	99	108	187	197

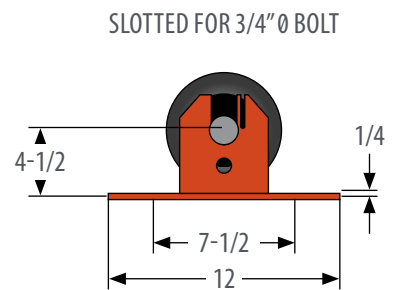
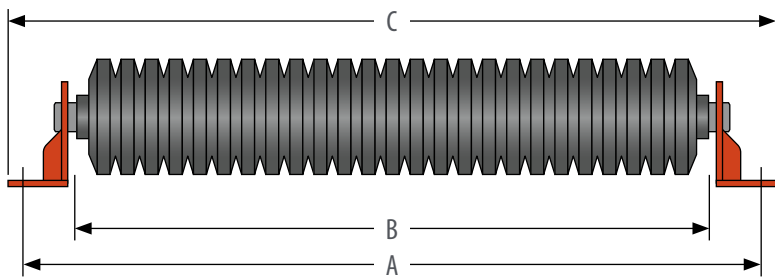

## RUBBER CUSHION FLAT IDLERS: 6" AND 7" DIAMETER

PART NUMBER		BW	A	B	C	WT (#)	
6"	7"					6"	7"
E6-FLTI-36	E7-FLTI-36	36	45	39-3/8	47-1/2	96	108
E6-FLTI-42	E7-FLTI-42	42	51	45-3/8	53-1/2	107	122
E6-FLTI-48	E7-FLTI-48	48	57	51-3/8	59-1/2	119	135
E6-FLTI-54	E7-FLTI-54	54	63	57-3/8	65-1/2	132	150
E6-FLTI-60	E7-FLTI-60	60	69	63-3/8	71-1/2	144	164
E6-FLTI-72	E7-FLTI-72	72	81	75-3/8	83-1/2	167	191
E6-FLTI-84	E7-FLTI-84	84	93	87-3/8	95-1/2	191	218
E6-FLTI-96	E7-FLTI-96	96	105	99-3/8	107-1/2	214	245

Add "TTM", "DRY", "WET", "LOW" to the end of the part number to add application specific seals.

# CEMA E IDLERS

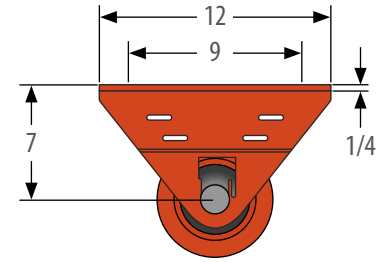
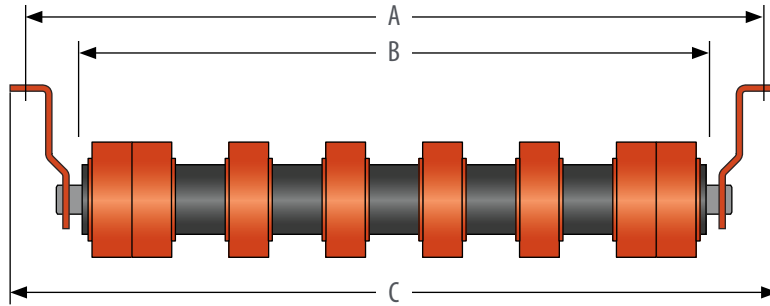

SLOTTED FOR 3/4" Ø BOLT

## URATHON® RETURN ROLLS: 6" AND 7" DIAMETER

PART NUMBER		BW	A	B	C	WT (#)	
6"	7"					6"	7"
E6-RETU-36	E7-RETU-36	36	45	39-3/8	48	88	95
E6-RETU-42	E7-RETU-42	42	51	45-3/8	54	99	107
E6-RETU-48	E7-RETU-48	48	57	51-3/8	60	109	116
E6-RETU-54	E7-RETU-54	54	63	57-3/8	66	120	129
E6-RETU-60	E7-RETU-60	60	69	63-3/8	72	131	141
E6-RETU-72	E7-RETU-72	72	81	75-3/8	84	155	168
E6-RETU-84	E7-RETU-84	84	93	87-3/8	96	175	189
E6-RETU-96	E7-RETU-96	96	105	99-3/8	108	196	211

Add "TTM", "DRY", "WET", "LOW" to the end of the part number to add application specific seals.

# CEMA E IDLERS

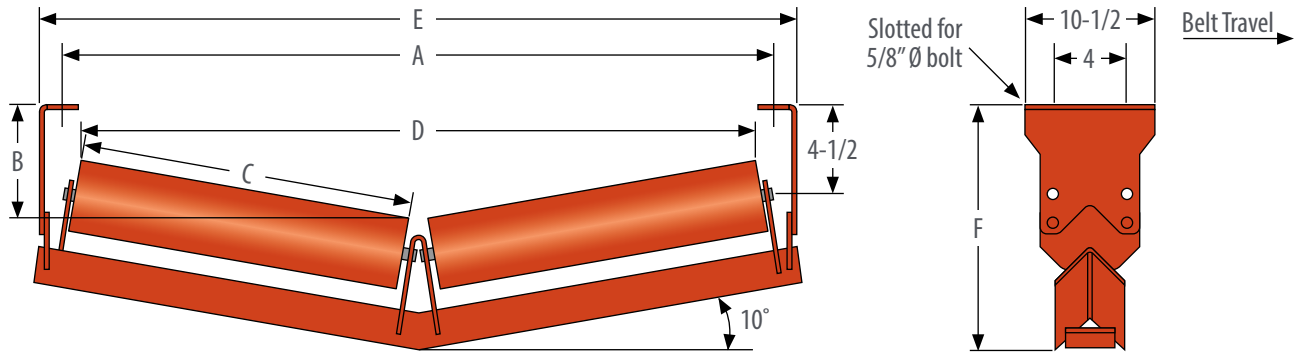

For wider base use next size larger belt width. Also available in 15°.

## V-RETURN IDLERS: 6" AND 7" DIAMETER

PART NUMBER		BW	A	B		C	D		E	F	WT (#)	
6"	7"			6"	7"		6"	7"			6"	7"
E6-10RETV-36	E7-10RETV-36	36	45	7-3/4	7-1/4	20-1/2	42-3/4	42-9/16	48-1/2	16-5/16	200	211
E6-10RETV-42	E7-10RETV-42	42	51	8-1/4	7-3/4	23-1/2	48-3/4	48-9/16	54-1/2	16-13/16	221	233
E6-10RETV-48	E7-10RETV-48	48	57	8-13/16	8-5/16	26-1/2	54-3/4	54-9/16	60-1/2	17-3/8	242	255
E6-10RETV-54	E7-10RETV-54	54	63	9-5/16	8-13/16	29-1/2	60-3/4	60-9/16	66-1/2	17-7/8	262	277
E6-10RETV-60	E7-10RETV-60	60	69	9-15/16	9-7/16	33	66-3/4	66-9/16	72-1/2	18-7/16	285	301
E6-10RETV-72	E7-10RETV-72	72	81	10-15/16	10-7/16	39	78-3/4	78-9/16	84-1/2	19-1/2	326	345
E6-10RETV-84	E7-10RETV-84	84	93	12	11-1/2	45	90-11/16	90-9/16	96-1/2	20-9/16	368	389
E6-10RETV-96	E7-10RETV-96	96	105	13-1/16	12-9/16	51	102-3/4	102-9/16	108-1/2	21-9/16	409	433

Add "TTM", "DRY", "WET", "LOW" to the end of the part number to add application specific seals.



# CEMA E IDLERS

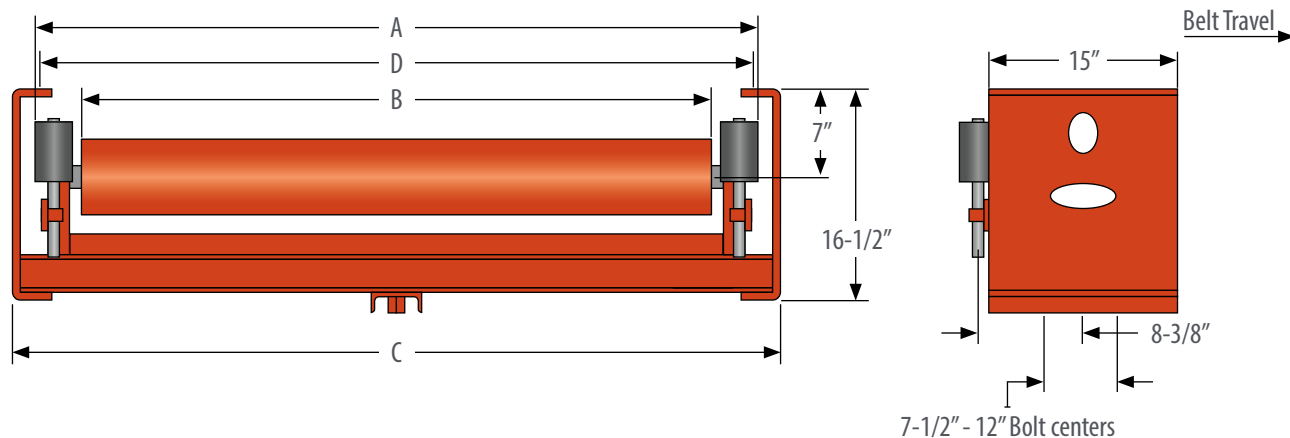

## RETURN SELF-ALIGNER IDLERS: 6" AND 7" DIAMETER

PART NUMBER		BW	A	B	C	D	WT (#)	
6"	7"						6"	7"
E6-RETA-36	E7-RETA-36	36	45-1/2	39	48-1/2	45	285	294
E6-RETA-42	E7-RETA-42	42	51-1/2	45	54-1/2	51	308	319
E6-RETA-48	E7-RETA-48	48	57-1/2	51	60-1/2	57	331	343
E6-RETA-54	E7-RETA-54	54	63 1/2	57	66-1/2	63	355	368
E6-RETA-60	E7-RETA-60	60	69-1/2	63	72-1/2	69	377	392
E6-RETA-72	E7-RETA-72	72	81-1/2	75	84-1/2	81	423	440
E6-RETA-84	E7-RETA-84	84	93-1/2	87	96-1/2	93	469	489
E6-RETA-96	E7-RETA-96	96	105-1/2	99	108-1/2	105	515	538

Add "TTM", "DRY", "WET", "LOW" to the end of the part number to add application specific seals.

# 40DT IDLERS

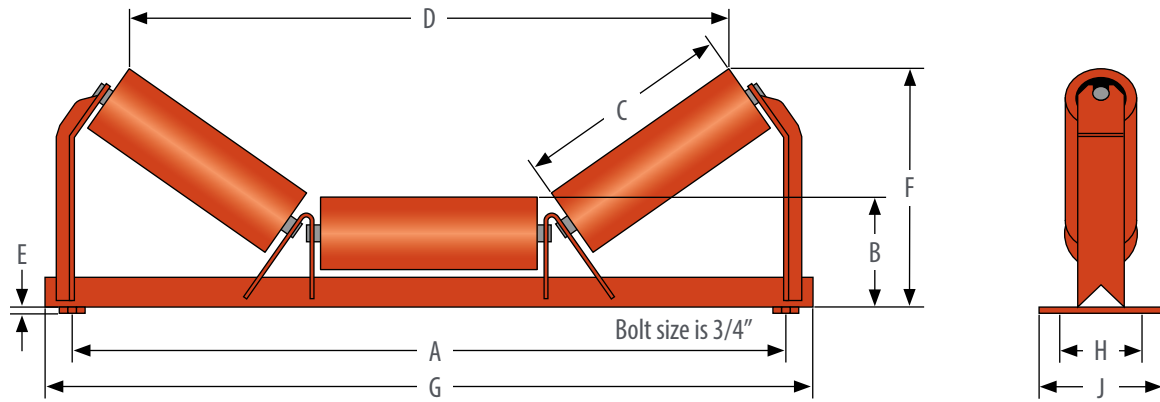

## TROUGHING IDLER (EQUAL LENGTH ROLLERS): 6" AND 7" DIAMETER

	PART NUMBER		BW	A	B		C	D		E	F		G	H	J	WT (#)	
	6"	7"			6"	7"		6"	7"		6"	7"				6"	7"
20°	E6-20E-36-40DT	E7-20E-36-40DT	36	45	10-3/4	11-1/4	12-3/4	39-7/8	39-1/2	1/2	15-3/8	15-13/16	49	9-1/2	14	169	175
	E6-20E-42-40DT	E7-20E-42-40DT	42	51	10-3/4	11-1/4	14-3/4	45-5/8	45-1/4	1/2	16-1/16	16-1/2	55	9-1/2	14	186	193
	E6-20E-48-40DT	E7-20E-48-40DT	48	57	10-3/4	11-1/4	17-1/2	53-9/16	53-3/16	1/2	17	17-7/16	63	9-1/2	14	211	219
	E6-20E-54-40DT	E7-20E-54-40DT	54	63	10-3/4	11-1/4	19-1/2	59-5/16	58-15/16	1/2	17-11/16	18-1/8	68-1/2	9-1/2	14	228	238
	E6-20E-60-40DT	E7-20E-60-40DT	60	69	10-3/4	11-1/4	21-1/2	65-1/16	64-11/16	1/2	18-3/8	18-13/16	74-1/4	9-1/2	14	246	256
	E6-20E-72-40DT	E7-20E-72-40DT	72	81	11-7/16	11-15/16	25-1/2	76-9/16	76-3/16	1/2	20-1/2	20-15/16	86	9-1/2	14	298	311
35°	E6-35E-36-40DT	E7-35E-36-40DT	36	45	10-3/4	11-1/4	12-3/4	35-13/16	35-1/4	1/2	18-1/4	18-11/16	49	9-1/2	14	174	180
	E6-35E-42-40DT	E7-35E-42-40DT	42	51	10-3/4	11-1/4	14-3/4	41-1/16	40-1/2	1/2	19-7/16	19-13/16	55	9-1/2	14	192	199
	E6-35E-48-40DT	E7-35E-48-40DT	48	57	10-3/4	11-1/4	17-1/2	48-5/16	47-3/4	1/2	21	21-7/16	63	9-1/2	14	217	226
	E6-35E-54-40DT	E7-35E-54-40DT	54	63	10-3/4	11-1/4	19-1/2	53-5/8	53-1/16	1/2	22-1/8	22-9/16	68-1/2	9-1/2	14	235	245
	E6-35E-60-40DT	E7-35E-60-40DT	60	69	10-3/4	11-1/4	21-1/2	58-7/8	58-5/16	1/2	23-5/16	23-11/16	74-1/4	9-1/2	14	254	264
	E6-35E-72-40DT	E7-35E-72-40DT	72	81	11-7/16	11-15/16	25-1/2	69-7/16	68-7/8	1/2	26-3/8	26-3/4	86	9-1/2	14	306	318
45°	E6-45E-36-40DT	E7-45E-36-40DT	36	45	10-3/4	11-1/4	12-3/4	32-5/16	31-5/8	1/2	19-15/16	20-5/16	49	9-1/2	14	178	184
	E6-45E-42-40DT	E7-45E-42-40DT	42	51	10-3/4	11-1/4	14-3/4	37-1/8	36-7/16	1/2	21-3/8	21-11/16	55	9-1/2	14	197	204
	E6-45E-48-40DT	E7-45E-48-40DT	48	57	10-3/4	11-1/4	17-1/2	43-3/4	43-1/16	1/2	23-5/16	23-5/8	63	9-1/2	14	222	231
	E6-45E-54-40DT	E7-45E-54-40DT	54	63	10-3/4	11-1/4	19-1/2	48-5/8	47-15/16	1/2	24-11/16	26-1/16	68-1/2	9-1/2	14	241	250
	E6-45E-60-40DT	E7-45E-60-40DT	60	69	10-3/4	11-1/4	21-1/2	53-7/16	52-3/4	1/2	26-1/8	26-1/2	74-1/4	9-1/2	14	259	270
	E6-45E-72-40DT	E7-45E-72-40DT	72	81	11-7/16	11-15/16	25-1/2	63-1/16	62-3/8	1/2	29-11/16	30-1/16	86	9-1/2	14	312	324

# 40DT IDLERS

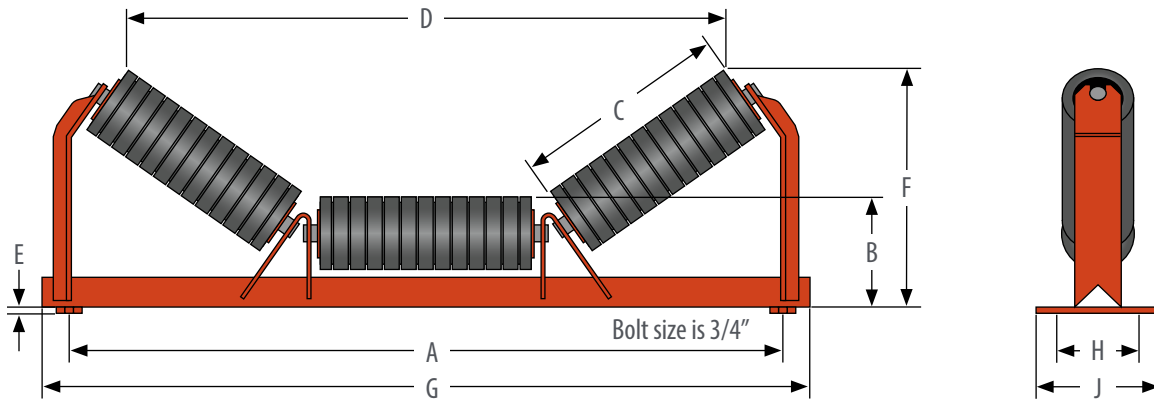

## RUBBER CUSHION IMPACT TROUGHING IDLERS: 6" AND 7" DIAMETER

	PART NUMBER		BW	A	B		C	D		E	F		G	H	J	WT (#)	
	6"	7"			6"	7"		6"	7"		6"	7"				6"	7"
20°	E6-20EI-36-40DT	E7-20EI-36-40DT	36	45	10-3/4	11-1/4	13-1/8	37-3/4	37-3/8	1/2	15-1/16	15-1/2	49	9-1/2	14	173	187
	E6-20EI-42-40DT	E7-20EI-42-40DT	42	51	10-3/4	11-1/4	15-1/8	43-1/2	43-1/8	1/2	15-3/4	16-3/16	55	9-1/2	14	191	207
	E6-20EI-48-40DT	E7-20EI-48-40DT	48	57	10-3/4	11-1/4	17-7/8	51-7/16	51-1/16	1/2	16-11/16	17-1/8	63	9-1/2	14	216	235
	E6-20EI-54-40DT	E7-20EI-54-40DT	54	63	10-3/4	11-1/4	19-7/8	57-3/16	56-7/8	1/2	17-3/16	17-13/16	68-1/2	9-1/2	14	234	255
	E6-20EI-60-40DT	E7-20EI-60-40DT	60	69	10-3/4	11-1/4	21-7/8	62-15/16	62-9/16	1/2	18-1/16	18-1/2	74-1/4	9-1/2	14	252	276
	E6-20EI-72-40DT	E7-20EI-72-40DT	72	81	11-7/16	11-15/16	25-7/8	74-7/16	74-1/8	1/2	20-3/16	20-5/8	86	9-1/2	14	305	333
35°	E6-35EI-36-40DT	E7-35EI-36-40DT	36	45	10-3/4	11-1/4	13-1/8	33-7/8	33-5/16	1/2	17-3/4	18-3/16	49	9-1/2	14	178	192
	E6-35EI-42-40DT	E7-35EI-42-40DT	42	51	10-3/4	11-1/4	15-1/8	39-3/16	38-9/16	1/2	18-15/16	19-5/16	55	9-1/2	14	197	213
	E6-35EI-48-40DT	E7-35EI-48-40DT	48	57	10-3/4	11-1/4	17-7/8	46-7/16	45-7/8	1/2	20-1/2	20-7/8	63	9-1/2	14	222	242
	E6-35EI-54-40DT	E7-35EI-54-40DT	54	63	10-3/4	11-1/4	19-7/8	54-15/16	51-1/8	1/2	21-1/2	22-1/16	68-1/2	9-1/2	14	241	262
	E6-35EI-60-40DT	E7-35EI-60-40DT	60	69	10-3/4	11-1/4	21-7/8	56-15/16	56-3/8	1/2	22-13/16	23-3/16	74-1/4	9-1/2	14	259	283
	E6-35EI-72-40DT	E7-35EI-72-40DT	72	81	11-7/16	11-15/16	25-7/8	67-1/2	66-15/16	1/2	25-13/16	26-1/4	86	9-1/2	14	312	340
45°	E6-45EI-36-40DT	E7-45EI-36-40DT	36	45	10-3/4	11-1/4	13-1/8	30-5/8	29-7/8	1/2	19-1/4	19-5/8	49	9-1/2	14	182	196
	E6-45EI-42-40DT	E7-45EI-42-40DT	42	51	10-3/4	11-1/4	15-1/8	35-7/16	36-11/16	1/2	20-11/16	21-1/16	55	9-1/2	14	201	218
	E6-45EI-48-40DT	E7-45EI-48-40DT	48	57	10-3/4	11-1/4	17-7/8	42-1/16	41-3/8	1/2	22-5/8	23	63	9-1/2	14	227	247
	E6-45EI-54-40DT	E7-45EI-54-40DT	54	63	10-3/4	11-1/4	19-7/8	45-15/16	46-3/16	1/2	24-1/16	24-7/16	68-1/2	9-1/2	14	246	268
	E6-45EI-60-40DT	E7-45EI-60-40DT	60	69	10-3/4	11-1/4	21-7/8	51-11/16	51	1/2	25-7/16	25-13/16	74-1/4	9-1/2	14	265	289
	E6-45EI-72-40DT	E7-45EI-72-40DT	72	81	11-7/16	11-15/16	25-7/8	61-3/8	60-11/16	1/2	29-1/16	29-3/8	86	9-1/2	14	318	347

# 40DT IDLERS

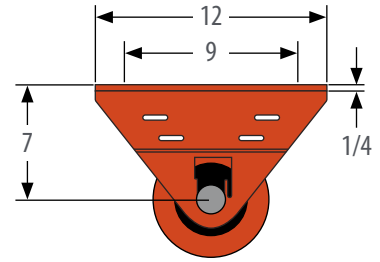
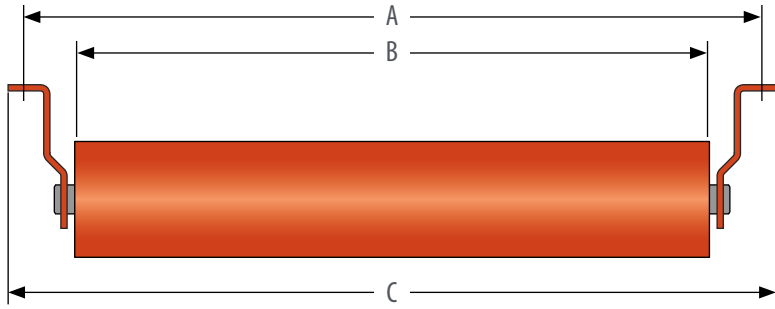

SLOTTED FOR 3/4" Ø BOLT

## RETURN IDLERS: 6" AND 7" DIAMETER

PART NUMBER		BW	A	B	C	WT (#)	
6"	7"					6"	7"
E6-RET-36-40DT	E7-RET-36-40DT	36	45	39	48	97	106
E6-RET-42-40DT	E7-RET-42-40DT	42	51	45	54	108	119
E6-RET-48-40DT	E7-RET-48-40DT	48	57	51	60	120	132
E6-RET-54-40DT	E7-RET-54-40DT	54	63	57	66	132	145
E6-RET-60-40DT	E7-RET-60-40DT	60	69	63	72	144	158
E6-RET-72-40DT	E7-RET-72-40DT	72	81	75	84	167	184

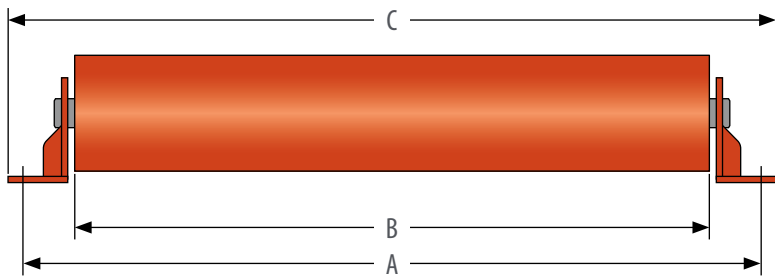

SLOTTED FOR 3/4" Ø BOLT

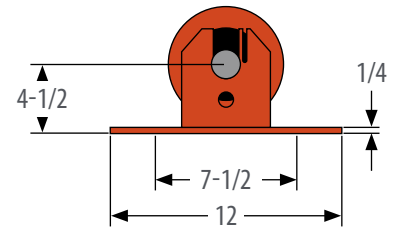

## FLAT IDLERS: 6" AND 7" DIAMETER

PART NUMBER		BW	A	B	C	WT (#)	
6"	7"					6"	7"
E6-FLT-36-40DT	E7-FLT-36-40DT	36	45	39	47-1/2	98	108
E6-FLT-42-40DT	E7-FLT-42-40DT	42	51	45	53-1/2	110	121
E6-FLT-48-40DT	E7-FLT-48-40DT	48	57	51	59-1/2	122	134
E6-FLT-54-40DT	E7-FLT-54-40DT	54	63	57	65-1/2	133	147
E6-FLT-60-40DT	E7-FLT-60-40DT	60	69	63	71-1/2	145	160
E6-FLT-72-40DT	E7-FLT-72-40DT	72	81	75	83-1/2	168	186

# 40DT IDLERS

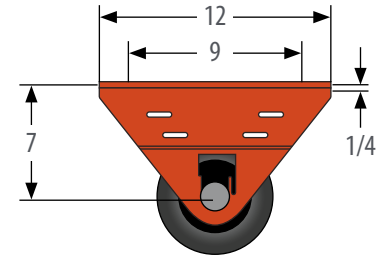
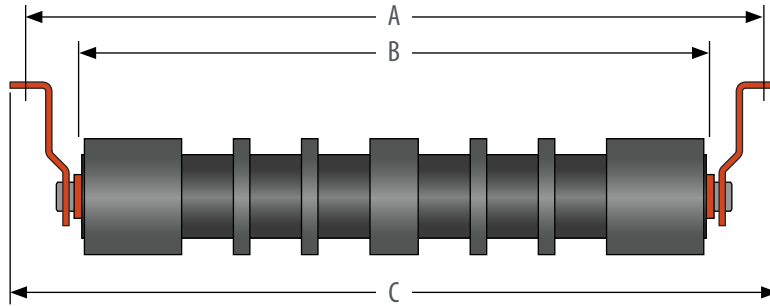

SLOTTED FOR 3/4" Ø BOLT

## RUBBER CUSHION RETURN IDLERS: 6" AND 7" DIAMETER

PART NUMBER		BW	A	B	C	WT (#)	
6"	7"					6"	7"
E6-RETI-36-40DT	E7-RETI-36-40DT	36	45	39	48	87	93
E6-RETI-42-40DT	E7-RETI-42-40DT	42	51	45	54	97	104
E6-RETI-48-40DT	E7-RETI-48-40DT	48	57	51	60	108	115
E6-RETI-54-40DT	E7-RETI-54-40DT	54	63	57	66	117	124
E6-RETI-60-40DT	E7-RETI-60-40DT	60	69	63	72	127	135
E6-RETI-72-40DT	E7-RETI-72-40DT	72	81	75	84	147	155

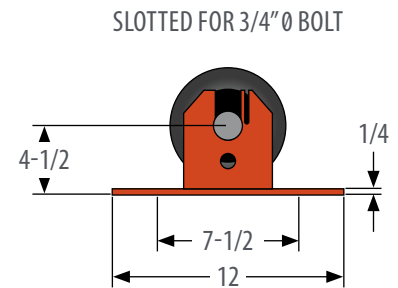
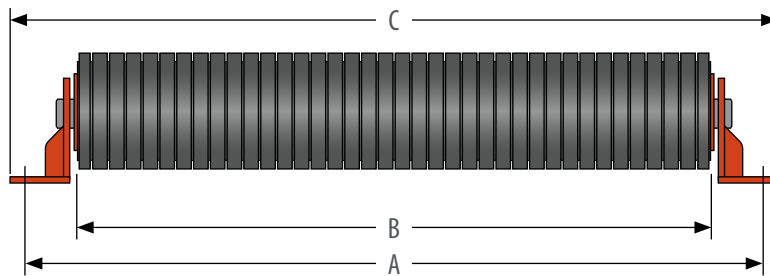

SLOTTED FOR 3/4" Ø BOLT

## RUBBER CUSHION FLAT IDLERS: 6" AND 7" DIAMETER

PART NUMBER		BW	A	B	C	WT (#)	
6"	7"					6"	7"
E6-FLTI-36-40DT	E7-FLTI-36-40DT	36	45	39-3/8	47-1/2	96	108
E6-FLTI-42-40DT	E7-FLTI-42-40DT	42	51	45-3/8	53-1/2	107	122
E6-FLTI-48-40DT	E7-FLTI-48-40DT	48	57	51-3/8	59-1/2	119	135
E6-FLTI-54-40DT	E7-FLTI-54-40DT	54	63	57-3/8	65-1/2	132	150
E6-FLTI-60-40DT	E7-FLTI-60-40DT	60	69	63-3/8	71-1/2	144	164
E6-FLTI-72-40DT	E7-FLTI-72-40DT	72	81	75-3/8	83-1/2	167	191

# 40DT IDLERS

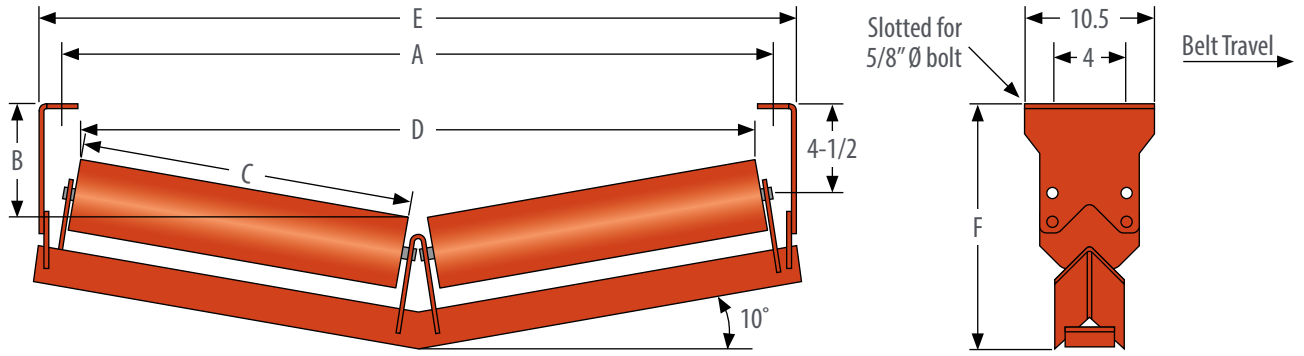

For wider base use next size larger belt width. Also available in 15°.

## V-RETURN IDLERS: 6" AND 7" DIAMETER

PART NUMBER		BW	A	B		C	D		E	F	WT (#)	
6"	7"			6"	7"		6"	7"			6"	7"
E6-10RETV-36-40DT	E7-10RETV-36-40DT	36	45	7-3/4	7-1/4	20-1/2	42-3/4	42-9/16	48-1/2	10-1/2	200	211
E6-10RETV-42-40DT	E7-10RETV-42-40DT	42	51	8-1/4	7-3/4	23-1/2	48-3/4	48-9/16	54-1/2	10-1/2	221	233
E6-10RETV-48-40DT	E7-10RETV-48-40DT	48	57	8-13/16	8-5/16	26-1/2	54-3/4	54-9/16	60-1/2	10-1/2	242	255
E6-10RETV-54-40DT	E7-10RETV-54-40DT	54	63	9-5/16	8-13/16	29-1/2	60-3/4	60-9/16	66-1/2	10-1/2	262	277
E6-10RETV-60-40DT	E7-10RETV-60-40DT	60	69	9-15/16	9-7/16	33	66-3/4	66-9/16	72-1/2	10-1/2	285	301
E6-10RETV-72-40DT	E7-10RETV-72-40DT	72	81	10-15/16	10-7/16	39	78-3/4	78-9/16	84-1/2	10-1/2	326	345
E6-10RETV-84-40DT	E7-10RETV-84-40DT	84	93	12	11-1/2	45	90-11/16	90-9/16	96-1/2	10-1/2	368	389
E6-10RETV-96-40DT	E7-10RETV-96-40DT	96	105	13-1/16	12-9/16	51	102-3/4	102-9/16	108-1/2	10-1/2	409	433

# 45DT IDLERS

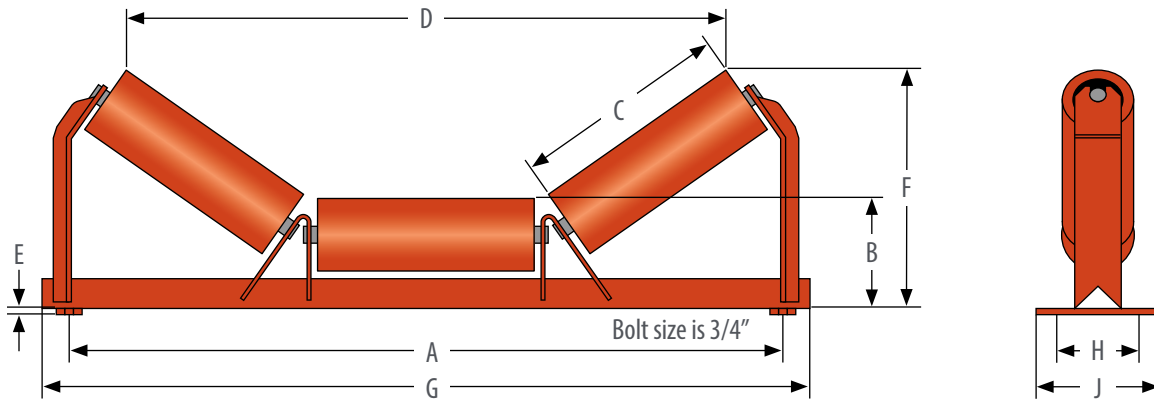

## TROUGHING IDLER (EQUAL LENGTH ROLLERS): 6" DIAMETER

	PART NUMBER	BW	A	B	C	D	E	F	G	H	J	WT (#)
20°	E6-20E-42-45DT	42	51	10-3/4	14-3/4	45-5/8	1/2	16	55	9-1/2	14	196
	E6-20E-48-45DT	48	57	10-3/4	17-1/2	53-1/2	1/2	17	63	9-1/2	14	222
	E6-20E-54-45DT	54	63	10-3/4	19-1/2	59-1/4	1/2	17-5/8	68-1/2	9-1/2	14	240
	E6-20E-60-45DT	60	69	10-3/4	21-1/2	65-1/16	1/2	18-5/16	74-1/4	9-1/2	14	259
	E6-20E-72-45DT	72	81	11-7/16	25-1/2	76-9/16	1/2	20-3/8	86	12	15	314
	E6-20E-84-45DT	84	93	11-11/16	29-1/2	88-1/16	1/2	22-1/16	97-1/2	12	15	354
	E6-20E-96-45DT	96	105	11-11/16	33-1/2	99-9/16	1/2	23-7/16	109	12	15	394
	E6-20E-108-45DT	108	117	11-11/16	37-1/2	111-1/8	1/2	24-13/16	120-1/2	12	15	434
35°	E6-35E-42-45DT	42	51	10-3/4	14-3/4	41-1/16	1/2	19-7/16	55	9-1/2	14	201
	E6-35E-48-45DT	48	57	10-3/4	17-1/2	48-5/16	1/2	21	63	9-1/2	14	228
	E6-35E-54-45DT	54	63	10-3/4	19-1/2	53-5/8	1/2	22-1/8	68-1/2	9-1/2	14	247
	E6-35E-60-45DT	60	69	10-3/4	21-1/2	58-7/8	1/2	23-5/16	74-1/4	9-1/2	14	267
	E6-35E-72-45DT	72	81	11-7/16	25-1/2	70-1/8	1/2	26-5/16	86	9-1/2	14	321
	E6-35E-84-45DT	84	93	11-11/16	29-1/2	79-15/16	1/2	28-15/16	97-1/2	12	15	364
	E6-35E-96-45DT	96	105	11-11/16	33-1/2	90-1/2	1/2	31-3/16	109	12	15	405
	E6-35E-108-45DT	108	117	11-11/16	37-1/2	101-1/16	1/2	33-1/2	120-1/2	12	15	445
45°	E6-45E-42-45DT	42	51	10-3/4	14-3/4	37-1/8	1/2	21-3/8	55	9-1/2	14	206
	E6-45E-48-45DT	48	57	10-3/4	17-1/2	43-3/4	1/2	23-5/16	63	9-1/2	14	233
	E6-45E-54-45DT	54	63	10-3/4	19-1/2	48-5/8	1/2	24-11/16	68-1/2	9-1/2	14	253
	E6-45E-60-45DT	60	69	10-3/4	21-1/2	53-7/16	1/2	26-1/8	74-1/4	9-1/2	14	272
	E6-45E-72-45DT	72	81	11-7/16	25-1/2	63-1/16	1/2	29-11/16	86	9-1/2	14	327
	E6-45E-84-45DT	84	93	11-11/16	29-1/2	72-11/16	1/2	32-13/16	97-1/2	12	15	371
	E6-45E-96-45DT	96	105	11-11/16	33-1/2	82-5/16	1/2	33-5/8	109	12	15	413
	E6-45E-108-45DT	108	117	11-11/16	37-1/2	92	1/2	38-7/16	120-1/2	12	15	454

# 45DT IDLERS

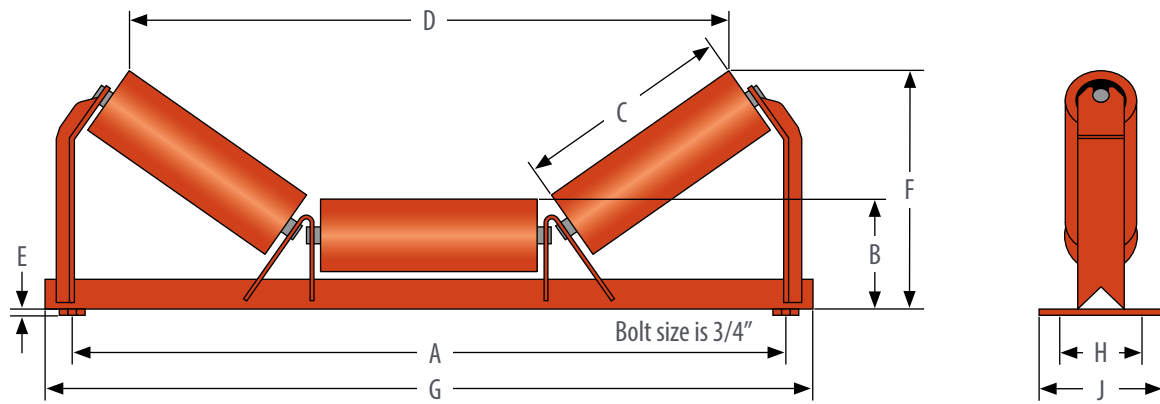

## TROUGHING IDLER (EQUAL LENGTH ROLLERS): 7" DIAMETER

	PART NUMBER	BW	A	B	C	D	E	F	G	H	J	WT (#)
20°	E7-20E-42-45DT	42	51	11-1/4	14-3/4	45-1/4	1/2	16-1/2	55	9-1/2	14	203
	E7-20E-48-45DT	48	57	11-1/4	17-1/2	53-3/16	1/2	17-7/16	63	9-1/2	14	231
	E7-20E-54-45DT	54	63	11-1/4	19-1/2	58-15/16	1/2	18-1/8	68-1/2	9-1/2	14	250
	E7-20E-60-45DT	60	69	11-1/4	21-1/2	64-11/16	1/2	18-13/16	74-1/4	9-1/2	14	270
	E7-20E-72-45DT	72	81	11-15/16	25-1/2	76-1/4	1/2	20-7/8	86	9-1/2	14	327
	E7-20E-84-45DT	84	93	12-3/16	29-1/2	87-3/4	1/2	22-9/16	97-1/2	12	15	369
	E7-20E-96-45DT	96	105	12-3/16	33-1/2	99-1/4	1/2	23-15/16	109	12	15	411
E7-20E-108-45DT	108	117	12-3/16	37-1/2	110-3/4	1/2	25-5/16	120-1/2	12	15	453	
35°	E7-35E-42-45DT	42	51	11-1/4	14-3/4	40-1/2	1/2	19-13/16	55	9-1/2	14	209
	E7-35E-48-45DT	48	57	11-1/4	17-1/2	47-3/4	1/2	21-7/16	63	9-1/2	14	237
	E7-35E-54-45DT	54	63	11-1/4	19-1/2	53-1/16	1/2	22-9/16	68-1/2	9-1/2	14	257
	E7-35E-60-45DT	60	69	11-1/4	21-1/2	58-5/16	1/2	23-11/16	74-1/4	9-1/2	14	278
	E7-35E-72-45DT	72	81	11-15/16	25-1/2	68-7/8	1/2	26-3/4	86	9-1/2	14	334
	E7-35E-84-45DT	84	93	12-3/16	29-1/2	79-7/16	1/2	29-5/16	97-1/2	12	15	379
	E7-35E-96-45DT	96	105	12-3/16	33-1/2	89-15/16	1/2	31-9/16	109	12	15	422
E7-35E-108-45DT	108	117	12-3/16	37-1/2	100-1/2	1/2	33-3/4	120-1/2	12	15	465	
45°	E7-45E-42-45DT	42	51	11-1/4	14-3/4	36-7/16	1/2	21-11/16	55	9-1/2	14	213
	E7-45E-48-45DT	48	57	11-1/4	17-1/2	43-1/16	1/2	23-5/8	63	9-1/2	14	242
	E7-45E-54-45DT	54	63	11-1/4	19-1/2	47-15/16	1/2	26-1/16	68-1/2	9-1/2	14	263
	E7-45E-60-45DT	60	69	11-1/4	21-1/2	52-3/4	1/2	26-1/2	74-1/4	9-1/2	14	283
	E7-45E-72-45DT	72	81	11-15/16	25-1/2	62-3/8	1/2	30-1/16	86	9-1/2	14	340
	E7-45E-84-45DT	84	93	12-3/16	29-1/2	72-1/16	1/2	33-1/8	97-1/2	12	15	386
	E7-45E-96-45DT	96	105	12-3/16	33-1/2	81-3/4	1/2	35-15/16	109	12	15	430
E7-45E-108-45DT	108	117	12-3/16	37-1/2	92-5/16	1/2	38-3/4	120-1/2	12	15	473	



# 45DT IDLERS

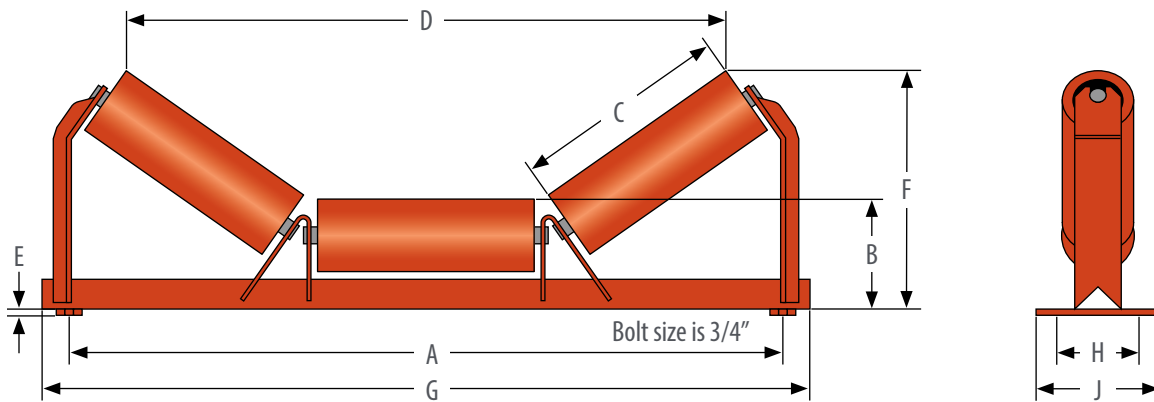

## TROUGHING IDLER (EQUAL LENGTH ROLLERS): 7.5" DIAMETER

	PART NUMBER	BW	A	B	C	D	E	F	G	H	J	WT (#)
20°	E7.5-20E-42-45DT	42	51	11-1/2	14-3/4	45-1/16	1/2	16-3/4	55	9-1/2	14	207
	E7.5-20E-48-45DT	48	57	11-1/2	17-1/2	53	1/2	17-5/8	63	9-1/2	14	235
	E7.5-20E-54-45DT	54	63	11-1/2	19-1/2	58-3/4	1/2	18-3/8	68-1/2	9-1/2	14	255
	E7.5-20E-60-45DT	60	69	11-1/2	21-1/2	64-1/2	1/2	19-1/16	74-1/4	9-1/2	14	275
	E7.5-20E-72-45DT	72	81	12-3/16	25-1/2	76-1/16	1/2	21-3/8	86	9-1/2	14	333
	E7.5-20E-84-45DT	84	93	12-7/16	29-1/2	87-9/16	1/2	22-13/16	97-1/2	12	15	376
	E7.5-20E-96-45DT	96	105	12-7/16	33-1/2	99-1/16	1/2	24-3/16	109	12	15	419
	E7.5-20E-108-45DT	108	117	12-7/16	37-1/2	110-9/16	1/2	25-9/16	120-1/2	12	15	462
35°	E7.5-35E-42-45DT	42	51	11-1/2	14-3/4	40-1/4	1/2	20	55	9-1/2	14	212
	E7.5-35E-48-45DT	48	57	11-1/2	17-1/2	47-1/2	1/2	21-5/8	63	9-1/2	14	241
	E7.5-35E-54-45DT	54	63	11-1/2	19-1/2	52-13/16	1/2	22-3/4	68-1/2	9-1/2	14	262
	E7.5-35E-60-45DT	60	69	11-1/2	21-1/2	58-1/16	1/2	23-7/8	74-1/4	9-1/2	14	283
	E7.5-35E-72-45DT	72	81	12-3/16	25-1/2	68-5/8	1/2	26-15/16	86	9-1/2	14	340
	E7.5-35E-84-45DT	84	93	12-7/16	29-1/2	79-3/16	1/2	29-5/8	97-1/2	12	15	386
	E7.5-35E-96-45DT	96	105	12-7/16	33-1/2	89-11/16	1/2	31-3/4	109	12	15	430
	E7.5-35E-108-45DT	108	117	12-7/16	37-1/2	100-1/4	1/2	33-15/16	120-1/2	12	15	474
45°	E7.5-45E-42-45DT	42	51	11-1/2	14-3/4	36-1/4	1/2	21-3/4	55	9-1/2	14	217
	E7.5-45E-48-45DT	48	57	11-1/2	17-1/2	42-7/8	1/2	23-13/16	63	9-1/2	14	246
	E7.5-45E-54-45DT	54	63	11-1/2	19-1/2	47-3/4	1/2	26-1/4	68-1/2	9-1/2	14	267
	E7.5-45E-60-45DT	60	69	11-1/2	21-1/2	52-9/16	1/2	26-11/16	74-1/4	9-1/2	14	289
	E7.5-45E-72-45DT	72	81	12-3/16	25-1/2	62-3/16	1/2	30-1/4	86	9-1/2	14	347
	E7.5-45E-84-45DT	84	93	12-7/16	29-1/2	71-7/8	1/2	33-7/16	97-1/2	12	15	393
	E7.5-45E-96-45DT	96	105	12-7/16	33-1/2	81-9/16	1/2	36-1/8	109	12	15	438
	E7.5-45E-108-45DT	108	117	12-7/16	37-1/2	92-1/8	1/2	38-15/16	120-1/2	12	15	482

# 45DT IDLERS

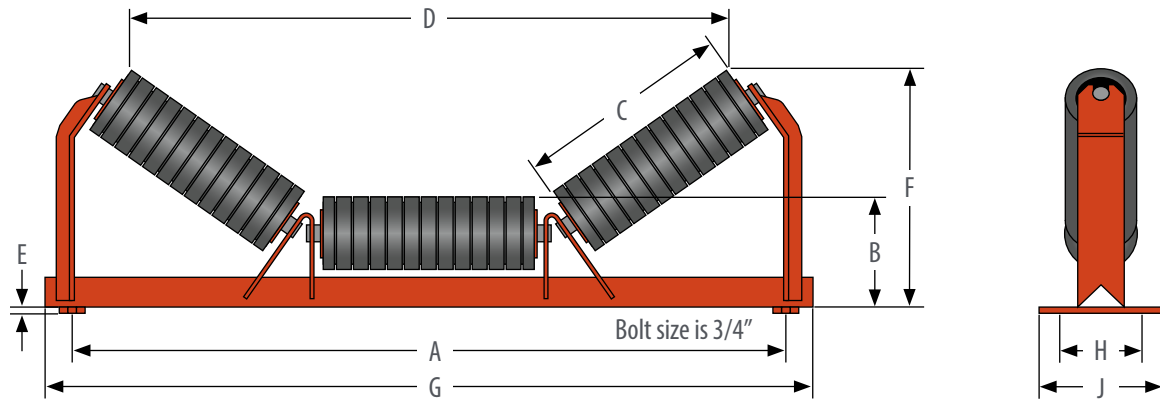

## RUBBER CUSHION IMPACT TROUGHING IDLERS: 6" DIAMETER

	PART NUMBER	BW	A	B	C	D	E	F	G	H	J	WT (#)
20°	E6-20EI-42-45DT	42	51	10-3/4	14-3/4	45-5/8	1/2	16	55	9-1/2	14	193
	E6-20EI-48-45DT	48	57	10-3/4	17-1/2	53-1/2	1/2	17	63	9-1/2	14	218
	E6-20EI-54-45DT	54	63	10-3/4	19-1/2	59-1/4	1/2	17-5/8	68-1/2	9-1/2	14	236
	E6-20EI-60-45DT	60	69	10-3/4	21-1/2	65-1/16	1/2	18-5/16	74-1/4	9-1/2	14	254
	E6-20EI-72-45DT	72	81	11-7/16	25-1/2	76-9/16	1/2	20-3/8	86	9-1/2	14	307
	E6-20EI-84-45DT	84	93	11-11/16	29-1/2	88-1/16	1/2	22-1/16	97-1/2	12	15	346
	E6-20EI-96-45DT	96	105	11-11/16	33-1/2	99-9/16	1/2	23-7/16	109	12	15	385
	E6-20EI-108-45DT	108	117	11-11/16	37-1/2	111-1/8	1/2	24-13/16	120-1/2	12	15	423
35°	E6-35EI-42-45DT	42	51	10-3/4	14-3/4	41-1/16	1/2	19-7/16	55	9-1/2	14	198
	E6-35EI-48-45DT	48	57	10-3/4	17-1/2	48-5/16	1/2	21	63	9-1/2	14	224
	E6-35EI-54-45DT	54	63	10-3/4	19-1/2	53-5/8	1/2	22-1/8	68-1/2	9-1/2	14	243
	E6-35EI-60-45DT	60	69	10-3/4	21-1/2	58-7/8	1/2	23-5/16	74-1/4	9-1/2	14	261
	E6-35EI-72-45DT	72	81	11-7/16	25-1/2	70-1/8	1/2	26-5/16	86	9-1/2	14	314
	E6-35EI-84-45DT	84	93	11-11/16	29-1/2	79-15/16	1/2	28-15/16	97-1/2	12	15	356
	E6-35EI-96-45DT	96	105	11-11/16	33-1/2	90-1/2	1/2	31-3/16	109	12	15	395
	E6-35EI-108-45DT	108	117	11-11/16	37-1/2	101-1/16	1/2	33-1/2	120-1/2	12	15	435
45°	E6-45EI-42-45DT	42	51	10-3/4	14-3/4	37-1/8	1/2	21-3/8	55	9-1/2	14	203
	E6-45EI-48-45DT	48	57	10-3/4	17-1/2	43-3/4	1/2	23-5/16	63	9-1/2	14	229
	E6-45EI-54-45DT	54	63	10-3/4	19-1/2	48-5/8	1/2	24-11/16	68-1/2	9-1/2	14	248
	E6-45EI-60-45DT	60	69	10-3/4	21-1/2	53-7/16	1/2	26-1/8	74-1/4	9-1/2	14	267
	E6-45EI-72-45DT	72	81	11-7/16	25-1/2	63-1/16	1/2	29-11/16	86	9-1/2	14	321
	E6-45EI-84-45DT	84	93	11-11/16	29-1/2	72-11/16	1/2	32-13/16	97-1/2	12	15	363
	E6-45EI-96-45DT	96	105	11-11/16	33-1/2	82-5/16	1/2	33-5/8	109	12	15	403
	E6-45EI-108-45DT	108	117	11-11/16	37-1/2	92	1/2	38-7/16	120-1/2	12	15	443

# 45DT IDLERS

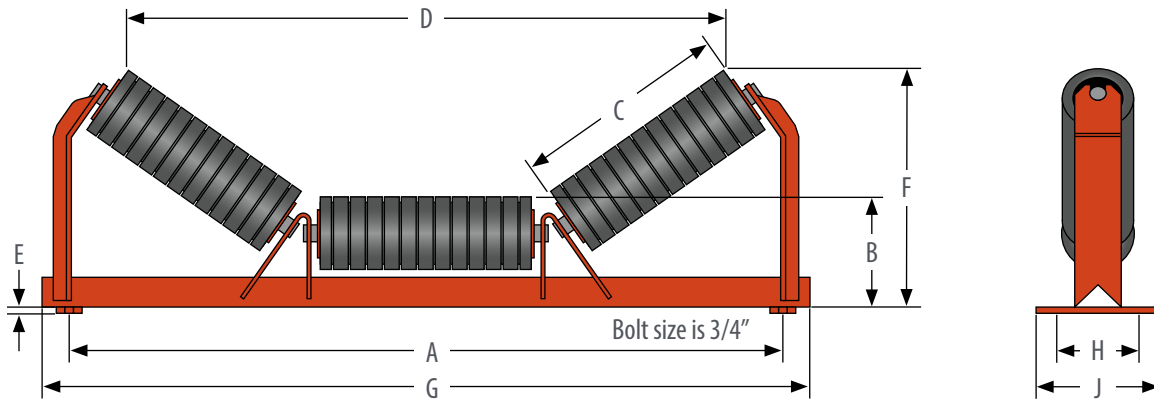

## RUBBER CUSHION IMPACT TROUGHING IDLERS: 7" DIAMETER

	PART NUMBER	BW	A	B	C	D	E	F	G	H	J	WT (#)
20°	E7-20EI-42-45DT	42	51	11-1/4	14-3/4	45-1/4	1/2	16-1/2	55	9-1/2	14	209
	E7-20EI-48-45DT	48	57	11-1/4	17-1/2	53-3/16	1/2	17-7/16	63	9-1/2	14	237
	E7-20EI-54-45DT	54	63	11-1/4	19-1/2	58-15/16	1/2	18-1/8	68-1/2	9-1/2	14	257
	E7-20EI-60-45DT	60	69	11-1/4	21-1/2	64-11/16	1/2	18-13/16	74-1/4	9-1/2	14	278
	E7-20EI-72-45DT	72	81	11-15/16	25-1/2	76-1/4	1/2	20-7/8	86	9-1/2	14	335
	E7-20EI-84-45DT	84	93	12-3/16	29-1/2	87-3/4	1/2	22-9/16	97-1/2	12	15	379
	E7-20EI-96-45DT	96	105	12-3/16	33-1/2	99-1/4	1/2	23-15/16	109	12	15	422
	E7-20EI-108-45DT	108	117	12-3/16	37-1/2	110-3/4	1/2	25-5/16	120-1/2	12	15	465
35°	E7-35EI-42-45DT	42	51	11-1/4	14-3/4	40-1/2	1/2	19-13/16	55	9-1/2	14	215
	E7-35EI-48-45DT	48	57	11-1/4	17-1/2	47-3/4	1/2	21-7/16	63	9-1/2	14	244
	E7-35EI-54-45DT	54	63	11-1/4	19-1/2	53-1/16	1/2	22-9/16	68-1/2	9-1/2	14	264
	E7-35EI-60-45DT	60	69	11-1/4	21-1/2	58-5/16	1/2	23-11/16	74-1/4	9-1/2	14	285
	E7-35EI-72-45DT	72	81	11-15/16	25-1/2	68-7/8	1/2	26-3/4	86	9-1/2	14	342
	E7-35EI-84-45DT	84	93	12-3/16	29-1/2	79-7/16	1/2	29-5/16	97-1/2	12	15	388
	E7-35EI-96-45DT	96	105	12-3/16	33-1/2	89-15/16	1/2	31-9/16	109	12	15	432
	E7-35EI-108-45DT	108	117	12-3/16	37-1/2	100-1/2	1/2	33-3/4	120-1/2	12	15	476
45°	E7-45EI-42-45DT	42	51	11-1/4	14-3/4	36-7/16	1/2	21-11/16	55	9-1/2	14	219
	E7-45EI-48-45DT	48	57	11-1/4	17-1/2	43-1/16	1/2	23-5/8	63	9-1/2	14	249
	E7-45EI-54-45DT	54	63	11-1/4	19-1/2	47-15/16	1/2	26-1/16	68-1/2	9-1/2	14	270
	E7-45EI-60-45DT	60	69	11-1/4	21-1/2	52-3/4	1/2	26-1/2	74-1/4	9-1/2	14	291
	E7-45EI-72-45DT	72	81	11-15/16	25-1/2	62-3/8	1/2	30-1/16	86	9-1/2	14	349
	E7-45EI-84-45DT	84	93	12-3/16	29-1/2	72-1/16	1/2	33-1/8	97-1/2	12	15	396
	E7-45EI-96-45DT	96	105	12-3/16	33-1/2	81-3/4	1/2	35-15/16	109	12	15	441
	E7-45EI-108-45DT	108	117	12-3/16	37-1/2	92-5/16	1/2	38-3/4	120-1/2	12	15	485

# 45DT IDLERS

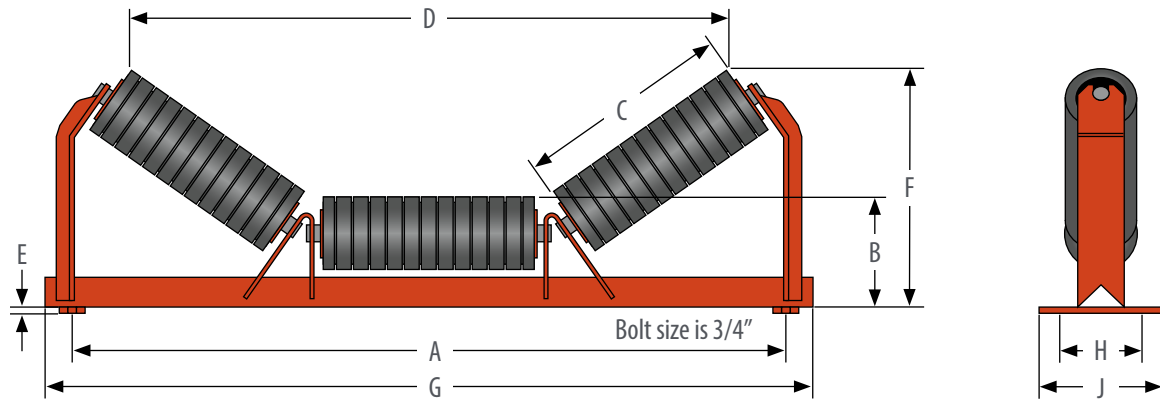

## RUBBER CUSHION IMPACT TROUGHING IDLERS: 7.5" DIAMETER

	PART NUMBER	BW	A	B	C	D	E	F	G	H	J	WT (#)
20°	E7.5-20EI-42-45DT	42	51	11-1/2	14-3/4	45-1/16	1/2	16-3/4	55	9-1/2	14	218
	E7.5-20EI-48-45DT	48	57	11-1/2	17-1/2	53	1/2	17-5/8	63	9-1/2	14	248
	E7.5-20EI-54-45DT	54	63	11-1/2	19-1/2	58-3/4	1/2	18-3/8	68-1/2	9-1/2	14	270
	E7.5-20EI-60-45DT	60	69	11-1/2	21-1/2	64-1/2	1/2	19-1/16	74-1/4	9-1/2	14	291
	E7.5-20EI-72-45DT	72	81	12-3/16	25-1/2	76-1/16	1/2	21-3/8	86	9-1/2	14	351
	E7.5-20EI-84-45DT	84	93	12-7/16	29-1/2	87-9/16	1/2	22-13/16	97-1/2	12	15	398
	E7.5-20EI-96-45DT	96	105	12-7/16	33-1/2	99-1/16	1/2	24-3/16	109	12	15	443
	E7.5-20EI-108-45DT	108	117	12-7/16	37-1/2	110-9/16	1/2	25-9/16	120-1/2	12	15	488
35°	E7.5-35EI-42-45DT	42	51	11-1/2	14-3/4	40-1/4	1/2	20	55	9-1/2	14	224
	E7.5-35EI-48-45DT	48	57	11-1/2	17-1/2	47-1/2	1/2	21-5/8	63	9-1/2	14	255
	E7.5-35EI-54-45DT	54	63	11-1/2	19-1/2	52-13/16	1/2	22-3/4	68-1/2	9-1/2	14	277
	E7.5-35EI-60-45DT	60	69	11-1/2	21-1/2	58-1/16	1/2	23-7/8	74-1/4	9-1/2	14	299
	E7.5-35EI-72-45DT	72	81	12-3/16	25-1/2	68-5/8	1/2	26-15/16	86	9-1/2	14	358
	E7.5-35EI-84-45DT	84	93	12-7/16	29-1/2	79-3/16	1/2	29-5/8	97-1/2	12	15	407
	E7.5-35EI-96-45DT	96	105	12-7/16	33-1/2	89-11/16	1/2	31-3/4	109	12	15	453
	E7.5-35EI-108-45DT	108	117	12-7/16	37-1/2	100-1/4	1/2	33-15/16	120-1/2	12	15	500
45°	E7.5-45EI-42-45DT	42	51	11-1/2	14-3/4	36-1/4	1/2	21-3/4	55	9-1/2	14	229
	E7.5-45EI-48-45DT	48	57	11-1/2	17-1/2	42-7/8	1/2	23-13/16	63	9-1/2	14	260
	E7.5-45EI-54-45DT	54	63	11-1/2	19-1/2	47-3/4	1/2	26-1/4	68-1/2	9-1/2	14	282
	E7.5-45EI-60-45DT	60	69	11-1/2	21-1/2	52-9/16	1/2	26-11/16	74-1/4	9-1/2	14	305
	E7.5-45EI-72-45DT	72	81	12-3/16	25-1/2	62-3/16	1/2	30-1/4	86	9-1/2	14	365
	E7.5-45EI-84-45DT	84	93	12-7/16	29-1/2	71-7/8	1/2	33-7/16	97-1/2	12	15	415
	E7.5-45EI-96-45DT	96	105	12-7/16	33-1/2	81-9/16	1/2	36-1/8	109	12	15	462
	E7.5-45EI-108-45DT	108	117	12-7/16	37-1/2	92-1/8	1/2	38-15/16	120-1/2	12	15	509

# 45DT IDLERS

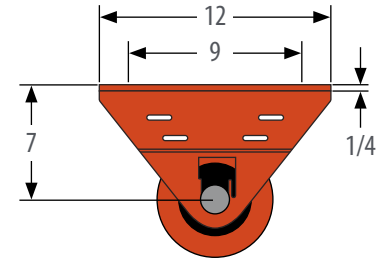
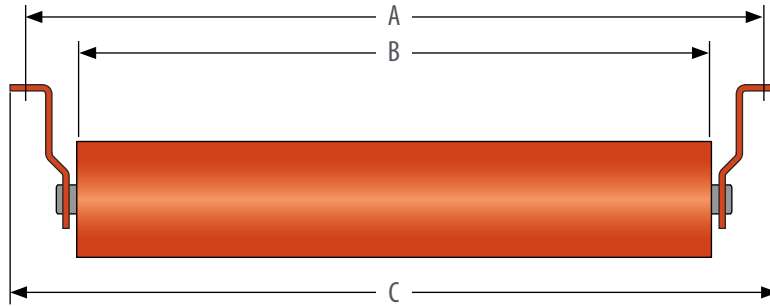

SLOTTED FOR 3/4" Ø BOLT

## RETURN IDLERS: 6", 7" AND 7.5" DIAMETER

PART NUMBER			BW	A	B	C	WT (#)		
6"	7"	7.5"					6"	7"	7.5"
E6-RET-42-45DT	E7-RET-42-45DT	E7.5-RET-42-45DT	42	51	45	54	122	135	141
E6-RET-48-45DT	E7-RET-48-45DT	E7.5-RET-48-45DT	48	57	51	60	135	150	157
E6-RET-54-45DT	E7-RET-54-45DT	E7.5-RET-54-45DT	54	63	57	66	149	165	173
E6-RET-60-45DT	E7-RET-60-45DT	E7.5-RET-60-45DT	60	69	63	72	162	179	188
E6-RET-72-45DT	E7-RET-72-45DT	E7.5-RET-72-45DT	72	81	75	84	188	209	219
E6-RET-84-45DT	E7-RET-84-45DT	E7.5-RET-84-45DT	84	93	87	96	215	238	250
E6-RET-96-45DT	E7-RET-96-45DT	E7.5-RET-96-45DT	96	105	99	108	241	268	281
E6-RET-108-45DT	E7-RET-108-45DT	E7.5-RET-108-45DT	108	117	111	119	267	298	312

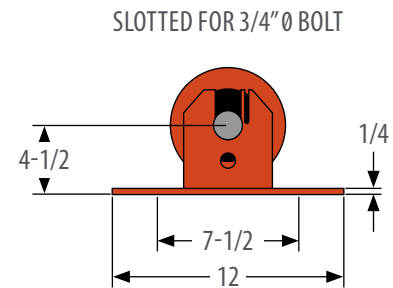
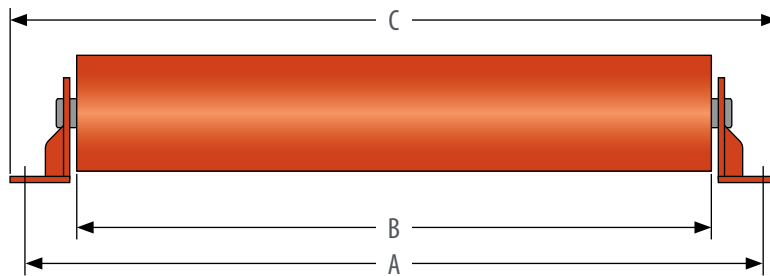

SLOTTED FOR 3/4" Ø BOLT

## FLAT IDLERS: 6", 7" AND 7.5" DIAMETER

PART NUMBER			BW	A	B	C	WT (#)		
6"	7"	7.5"					6"	7"	7.5"
E6-FLT-42-45DT	E7-FLT-42-45DT	E7.5-FLT-42-45DT	42	51	45	53-1/2	122	135	141
E6-FLT-48-45DT	E7-FLT-48-45DT	E7.5-FLT-48-45DT	48	57	51	59-1/2	135	150	157
E6-FLT-54-45DT	E7-FLT-54-45DT	E7.5-FLT-54-45DT	54	63	57	65-1/2	149	165	173
E6-FLT-60-45DT	E7-FLT-60-45DT	E7.5-FLT-60-45DT	60	69	63	71-1/2	162	179	188
E6-FLT-72-45DT	E7-FLT-72-45DT	E7.5-FLT-72-45DT	72	81	75	83-1/2	188	209	219
E6-FLT-84-45DT	E7-FLT-84-45DT	E7.5-FLT-84-45DT	84	93	87	95-1/2	215	238	250
E6-FLT-96-45DT	E7-FLT-96-45DT	E7.5-FLT-96-45DT	96	105	99	107-1/2	241	268	281
E6-FLT-108-45DT	E7-FLT-108-45DT	E7.5-FLT-108-45DT	108	117	111	119-1/2	267	298	312

# 45DT IDLERS

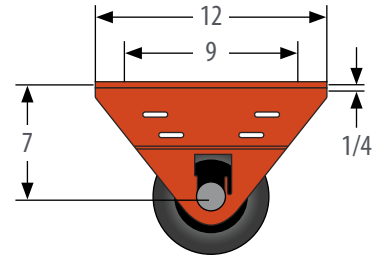
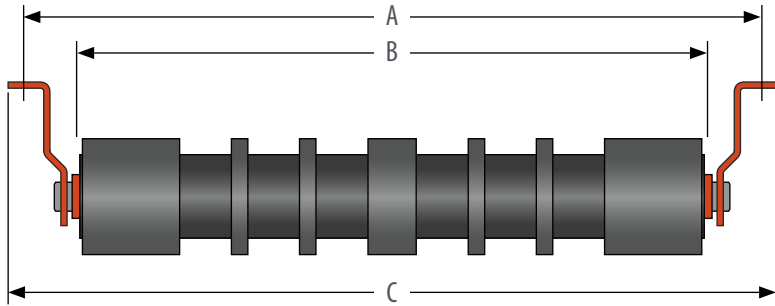

SLOTTED FOR 3/4" Ø BOLT

## RUBBER CUSHION RETURN IDLERS: 6" AND 7" DIAMETER

PART NUMBER			BW	A	B	C	WT (#)		
6"	7"	7.5"					6"	7"	7.5"
E6-RETI-42-45DT	E7-RETI-42-45DT	E7.5-RETI-42-45DT	42	51	45-3/8	54	111	117	120
E6-RETI-48-45DT	E7-RETI-48-45DT	E7.5-RETI-48-45DT	48	57	51-3/8	60	123	129	132
E6-RETI-54-45DT	E7-RETI-54-45DT	E7.5-RETI-54-45DT	54	63	57-3/8	66	134	139	142
E6-RETI-60-45DT	E7-RETI-60-45DT	E7.5-RETI-60-45DT	60	69	63-3/8	72	146	152	154
E6-RETI-72-45DT	E7-RETI-72-45DT	E7.5-RETI-72-45DT	72	81	75-3/8	84	168	174	177
E6-RETI-84-45DT	E7-RETI-84-45DT	E7.5-RETI-84-45DT	84	93	87-3/8	96	192	198	201
E6-RETI-96-45DT	E7-RETI-96-45DT	E7.5-RETI-96-45DT	96	105	99-3/8	108	214	221	224
E6-RETI-108-45DT	E7-RETI-108-45DT	E7.5-RETI-108-45DT	108	117	111-3/8	119	236	244	247

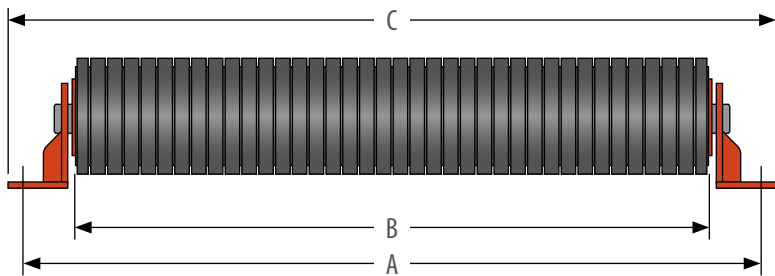

SLOTTED FOR 3/4" Ø BOLT

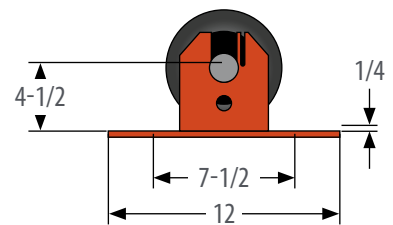

## RUBBER CUSHION FLAT IDLERS: 6" AND 7" DIAMETER

PART NUMBER			BW	A	B	C	WT (#)		
6"	7"	7.5"					6"	7"	7.5"
E6-FLTI-42-45DT	E7-FLTI-42-45DT	E7.5-FLTI-42-45DT	42	51	45-3/8	53-1/2	111	117	120
E6-FLTI-48-45DT	E7-FLTI-48-45DT	E7.5-FLTI-48-45DT	48	57	51-3/8	59-1/2	123	129	132
E6-FLTI-54-45DT	E7-FLTI-54-45DT	E7.5-FLTI-54-45DT	54	63	57-3/8	65-1/2	134	139	142
E6-FLTI-60-45DT	E7-FLTI-60-45DT	E7.5-FLTI-60-45DT	60	69	63-3/8	71-1/2	146	152	154
E6-FLTI-72-45DT	E7-FLTI-72-45DT	E7.5-FLTI-72-45DT	72	81	75-3/8	83-1/2	168	174	177
E6-FLTI-84-45DT	E7-FLTI-84-45DT	E7.5-FLTI-84-45DT	84	93	87-3/8	95-1/2	192	198	201
E6-FLTI-96-45DT	E7-FLTI-96-45DT	E7.5-FLTI-96-45DT	96	105	99-3/8	107-1/2	214	221	224
E6-FLTI-108-45DT	E7-FLTI-108-45DT	E7.5-FLTI-108-45DT	108	117	111-3/8	119-1/2	236	244	247

# 45DT IDLERS

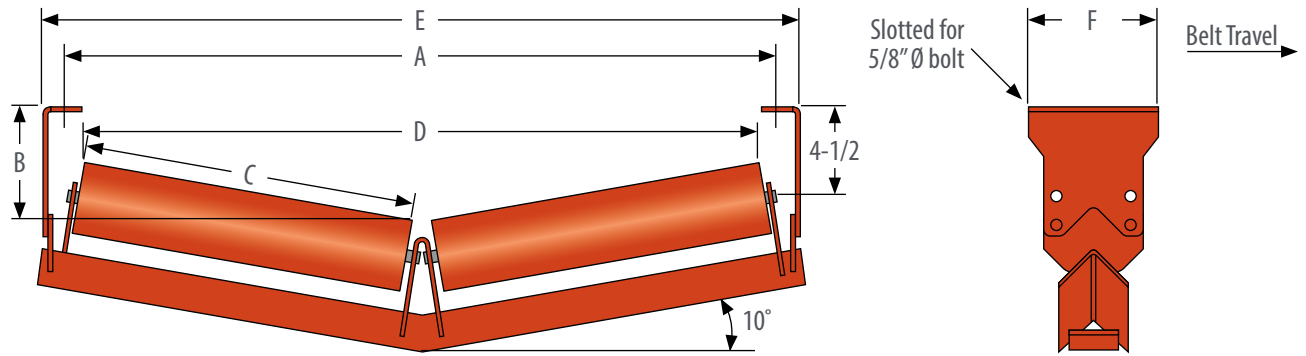

For wider base use next size larger belt width. Also available in 15°.

## V-RETURN IDLERS: 6", 7" AND 7.5" DIAMETER

PART NUMBERS			BW	A	B			C	D			E	F	WT (#)		
6"	7"	7.5"			6"	7"	7.5"		6"	7"	7.5"			6"	7"	7.5"
E6-10RETV-42-45DT	E7-10RETV-42-45DT	E7.5-10RETV-42-45DT	42	51	8-1/4	7-3/4	8	20-1/2	48-3/4	48-9/16	48-1/2	54-1/2	16-13/16	175	188	195
E6-10RETV-48-45DT	E7-10RETV-48-45DT	E7.5-10RETV-48-45DT	48	57	8-13/16	8-5/16	8-9/16	23-1/2	54-3/4	54-9/16	54-1/2	60-1/2	17-3/8	197	213	221
E6-10RETV-54-45DT	E7-10RETV-54-45DT	E7.5-10RETV-54-45DT	54	63	9-5/16	8-13/16	9-1/16	26-1/2	60-3/4	60-9/16	60-1/2	66-1/2	17-7/8	219	237	245
E6-10RETV-60-45DT	E7-10RETV-60-45DT	E7.5-10RETV-60-45DT	60	69	9-15/16	9-7/16	9-3/4	29-1/2	66-3/4	66-9/16	66-1/2	72-1/2	18-7/16	242	261	271
E6-10RETV-72-45DT	E7-10RETV-72-45DT	E7.5-10RETV-72-45DT	72	81	10-15/16	10-7/16	10-3/4	33	78-3/4	78-9/16	78-1/2	84-1/2	19-1/2	246	266	276
E6-10RETV-84-45DT	E7-10RETV-84-45DT	E7.5-10RETV-84-45DT	84	93	12	11-1/2	11-11/16	39	90-11/16	90-9/16	90-1/2	96-1/2	20-9/16	310	336	349
E6-10RETV-96-45DT	E7-10RETV-96-45DT	E7.5-10RETV-96-45DT	96	105	13-1/16	12-9/16	12-13/16	45	102-3/4	102-9/16	102-1/2	108-1/2	21-9/16	342	371	385
E6-10RETV-108-45DT	E7-10RETV-108-45DT	E7.5-10RETV-108-45DT	108	117	14-1/16	13-9/16	13-13/16	51	112-3/4	112-9/16	112-1/2	120-1/2	22-9/16	374	406	421

# CEMA F IDLERS

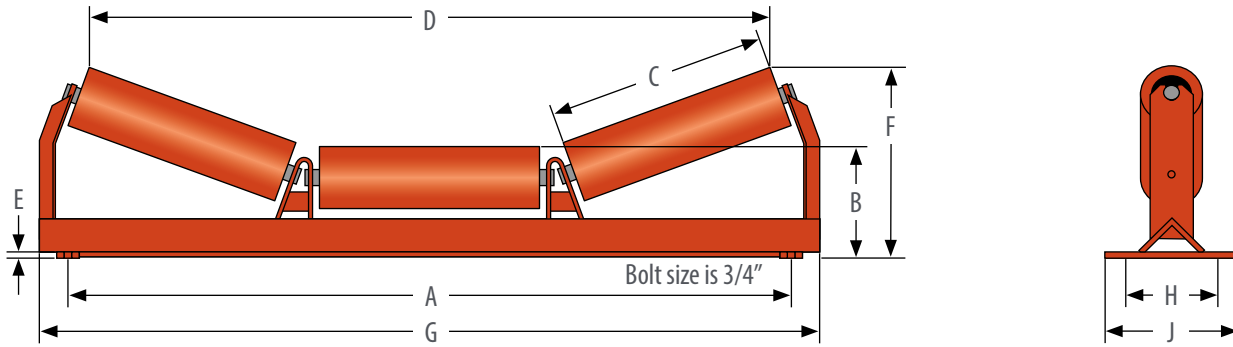

## TROUGHING IDLERS (EQUAL LENGTH ROLLERS): 6" DIAMETER

	PART NUMBER	BW	A	B	C	D	E	F	G	H	J	WT
20°	F6-20E-42-40MM	42	51	12	14-3/4	46-1/16	5/8	17-3/8	56-7/16	12	15	344
	F6-20E-48-40MM	48	57	12	17-1/2	54-1/16	5/8	18-5/16	64-7/16	12	15	388
	F6-20E-54-40MM	54	63	12	19-1/2	59-11/16	5/8	19	70-1/16	12	15	422
	F6-20E-60-40MM	60	69	12	21-1/2	65-1/2	5/8	19-11/16	75-13/16	12	15	456
	F6-20E-72-40MM	72	81	12	25-1/2	77-1/16	5/8	21-1/16	87-7/16	12	15	523
	F6-20E-84-40MM	84	93	12	29-1/2	88-5/8	5/8	22-7/16	99-1/16	12	15	591
	F6-20E-96-40MM	96	105	12	33-1/2	100-1/16	5/8	23-3/4	110-7/16	12	15	659
	F6-20E-108-40MM	108	117	12	37-1/2	111-9/16	5/8	25-1/8	121-15/16	12	15	727
	F6-20E-120-40MM	120	129	12	41-1/2	123-1/8	5/8	26-1/2	133-1/2	12	15	794
35°	F6-35E-42-40MM	42	51	12	14-3/4	41-3/8	5/8	20-13/16	56-7/16	12	15	350
	F6-35E-48-40MM	48	57	12	17-1/2	48-11/16	5/8	22-7/16	64-7/16	12	15	395
	F6-35E-54-40MM	54	63	12	19-1/2	53-7/8	5/8	23-9/16	70-1/16	12	15	430
	F6-35E-60-40MM	60	69	12	21-1/2	59-1/8	5/8	24-11/16	75-13/16	12	15	464
	F6-35E-72-40MM	72	81	12	25-1/2	69-13/16	5/8	27	87-7/16	12	15	533
	F6-35E-84-40MM	84	93	12	29-1/2	80-3/8	5/8	29-5/16	99-1/16	12	15	602
	F6-35E-96-40MM	96	105	12	33-1/2	90-7/8	5/8	31-9/16	110-7/16	12	15	700
	F6-35E-108-40MM	108	117	12	37-1/2	101-3/8	5/8	33-7/8	121-15/16	12	15	739
	F6-35E-120-40MM	120	129	12	41-1/2	111-15/16	5/8	36-3/16	133-1/2	12	15	808
45°	F6-45E-42-40MM	42	51	12	14-3/4	38-5/16	5/8	22-7/8	56-7/16	12	15	357
	F6-45E-48-40MM	48	57	12	17-1/2	45	5/8	24-7/8	64-7/16	12	15	403
	F6-45E-54-40MM	54	63	12	19-1/2	49-3/4	5/8	26-1/4	70-1/16	12	15	437
	F6-45E-60-40MM	60	69	12	21-1/2	54-9/16	5/8	27-11/16	75-13/16	12	15	472
	F6-45E-72-40MM	72	81	12	25-1/2	64-5/16	5/8	30-1/2	87-7/16	12	15	541
	F6-45E-84-40MM	84	93	12	29-1/2	73-15/16	5/8	33-5/16	99-1/16	12	15	611
	F6-45E-96-40MM	96	105	12	33-1/2	83-9/16	5/8	36-3/16	110-7/16	12	15	680
	F6-45E-108-40MM	108	117	12	37-1/2	93-1/4	5/8	39	121-15/16	12	15	750
	F6-45E-120-40MM	120	129	12	41-1/2	102-7/8	5/8	41-13/16	133-1/2	12	15	820

Also available in Aligners, Impacts, and Returns.



# CEMA F IDLERS

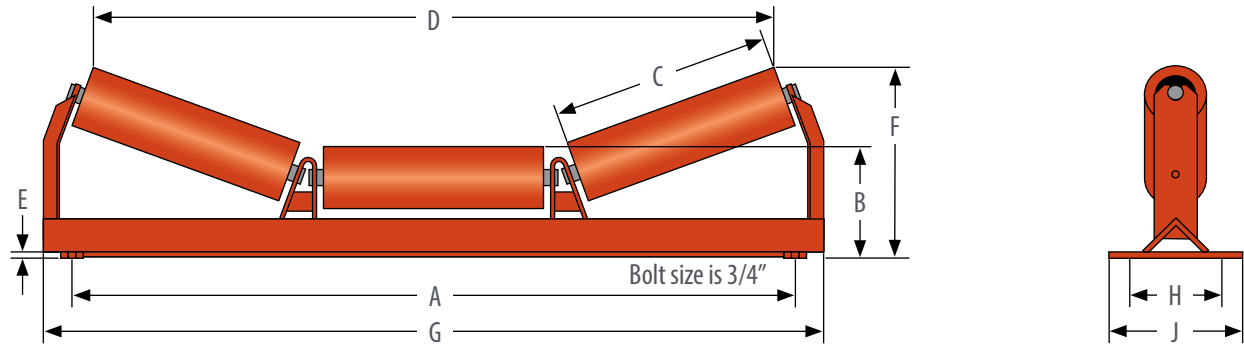

## TROUGHING IDLERS (EQUAL LENGTH ROLLERS): 7" DIAMETER

	PART NUMBER	BW	A	B	C	D	E	F	G	H	I	WT (#)
20°	F7-20E-42-40MM	42	51	12-1/2	14-3/4	45-3/4	5/8	17-13/16	56-7/16	12	15	407
	F7-20E-48-40MM	48	57	12-1/2	17-1/2	53-11/16	5/8	18-3/4	64-7/16	12	15	455
	F7-20E-54-40MM	54	63	12-1/2	19-1/2	45-3/4	5/8	17-3/4	70-1/16	12	15	491
	F7-20E-60-40MM	60	69	12-1/2	21-1/2	65-1/8	5/8	20-1/8	75-13/16	12	15	528
	F7-20E-72-40MM	72	81	12-1/2	25-1/2	76-3/4	5/8	21-1/2	87-7/16	12	15	601
	F7-20E-84-40MM	84	93	12-1/2	29-1/2	88-1/4	5/8	22-7/8	99-1/16	12	15	674
	F7-20E-96-40MM	96	105	12-1/2	33-1/2	99-3/4	5/8	24-1/4	110-7/16	12	15	747
	F7-20E-108-40MM	108	117	12-1/2	37-1/2	111-1/4	5/8	25-5/8	121-15/16	12	15	820
F7-20E-120-40MM	120	129	12-1/2	41-1/2	122-3/4	5/8	27	133-1/2	12	15	893	
35°	F7-35E-42-40MM	42	51	12-1/2	14-3/4	40-13/16	5/8	21-1/4	56-7/16	12	15	414
	F7-35E-48-40MM	48	57	12-1/2	17-1/2	48-1/8	5/8	22-13/16	64-7/16	12	15	462
	F7-35E-54-40MM	54	63	12-1/2	19-1/2	53-5/16	5/8	23-15/16	70-1/16	12	15	499
	F7-35E-60-40MM	60	69	12-1/2	21-1/2	58-9/16	5/8	25-1/8	75-13/16	12	15	536
	F7-35E-72-40MM	72	81	12-1/2	25-1/2	69-1/4	5/8	27-7/16	87-7/16	12	15	610
	F7-35E-84-40MM	84	93	12-1/2	29-1/2	79-13/16	5/8	29-11/16	99-1/16	12	15	685
	F7-35E-96-40MM	96	105	12-1/2	33-1/2	90-1/4	5/8	32	110-7/16	12	15	759
	F7-35E-108-40MM	108	117	12-1/2	37-1/2	100-13/16	5/8	34-5/16	121-15/16	12	15	833
F7-35E-120-40MM	120	129	12-1/2	41-1/2	111-3/8	5/8	36-9/16	133-1/2	12	15	907	
45°	F7-45E-42-40MM	42	51	12-1/2	14-3/4	37-5/8	5/8	23-1/4	56-7/16	12	15	420
	F7-45E-48-40MM	48	57	12-1/2	17-1/2	44-5/16	5/8	25-3/16	64-7/16	12	15	469
	F7-45E-54-40MM	54	63	12-1/2	19-1/2	49	5/8	26-5/8	70-1/16	12	15	507
	F7-45E-60-40MM	60	69	12-1/2	21-1/2	53-7/8	5/8	28	75-13/16	12	15	544
	F7-45E-72-40MM	72	81	12-1/2	25-1/2	63-5/8	5/8	30-7/8	87-7/16	12	15	619
	F7-45E-84-40MM	84	93	12-1/2	29-1/2	73-1/4	5/8	33-11/16	99-1/16	12	15	694
	F7-45E-96-40MM	96	105	12-1/2	33-1/2	82-7/8	5/8	36-1/2	110-7/16	12	15	768
	F7-45E-108-40MM	108	117	12-1/2	37-1/2	92-1/2	5/8	39-5/16	121-15/16	12	15	844
F7-45E-120-40MM	120	129	12-1/2	41-1/2	102-3/16	5/8	42-3/16	133-1/2	12	15	919	

Also available in Aligners, Impacts, and Returns.

# CEMA F IDLERS

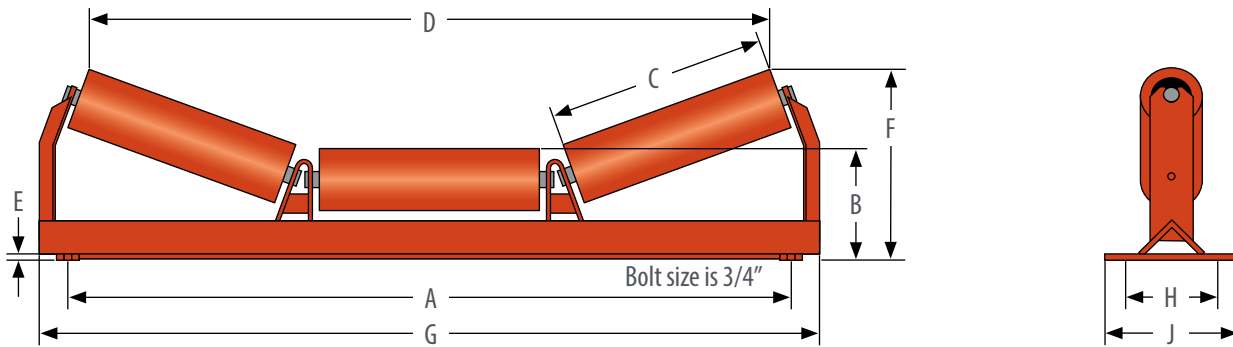

## TROUGHING IDLERS (EQUAL LENGTH ROLLERS): 8" DIAMETER

	PART NUMBER	BW	A	B	C	D	E	F	G	H	J	WT (#)
20°	F8-20E-42-40MM	42	51	13	14-3/4	45-3/8	5/8	18-5/16	56-7/16	12	15	478
	F8-20E-48-40MM	48	57	13	17-1/2	53-3/8	5/8	19-1/4	64-7/16	12	15	530
	F8-20E-54-40MM	54	63	13	19-1/2	59-1/16	5/8	19-15/16	70-1/16	12	15	569
	F8-20E-60-40MM	60	69	13	21-1/2	64-13/16	5/8	20-5/8	75-13/16	12	15	608
	F8-20E-72-40MM	72	81	13	25-1/2	76-7/16	5/8	22	87-7/16	12	15	687
	F8-20E-84-40MM	84	93	13	29-1/2	87-15/16	5/8	23-3/8	99-1/16	12	15	765
	F8-20E-96-40MM	96	105	13	33-1/2	99-3/8	5/8	24-11/16	110-7/16	12	15	843
	F8-20E-108-40MM	108	117	13	37-1/2	110-7/8	5/8	26-1/16	121-15/16	12	15	922
	F8-20E-120-40MM	120	129	13	41-1/2	122-7/16	5/8	27-7/16	133-1/2	12	15	1000
35°	F8-35E-42-40MM	42	51	13	14-3/4	40-1/4	5/8	21-5/8	56-7/16	12	15	485
	F8-35E-48-40MM	48	57	13	17-1/2	47-9/16	5/8	23-1/4	64-7/16	12	15	537
	F8-35E-54-40MM	54	63	13	19-1/2	52-3/4	5/8	24-3/8	70-1/16	12	15	577
	F8-35E-60-40MM	60	69	13	21-1/2	58	5/8	25-1/2	75-13/16	12	15	617
	F8-35E-72-40MM	72	81	13	25-1/2	68-5/8	5/8	27-13/16	87-7/16	12	15	696
	F8-35E-84-40MM	84	93	13	29-1/2	79-3/16	5/8	30-1/8	99-1/16	12	15	775
	F8-35E-96-40MM	96	105	13	33-1/2	89-11/16	5/8	32-7/16	110-7/16	12	15	855
	F8-35E-108-40MM	108	117	13	37-1/2	100-1/4	5/8	34-11/16	121-15/16	12	15	934
	F8-35E-120-40MM	120	129	13	41-1/2	110-13/16	5/8	37	133-1/2	12	15	1014
45°	F8-45E-42-40MM	42	51	13	14-3/4	36-7/8	5/8	23-5/8	56-7/16	12	15	491
	F8-45E-48-40MM	48	57	13	17-1/2	43-9/16	5/8	25-9/16	64-7/16	12	15	544
	F8-45E-54-40MM	54	63	13	19-1/2	48-5/16	5/8	26-15/16	70-1/16	12	15	584
	F8-45E-60-40MM	60	69	13	21-1/2	53-1/8	5/8	28-3/8	75-13/16	12	15	624
	F8-45E-72-40MM	72	81	13	25-1/2	62-7/8	5/8	31-3/16	87-7/16	12	15	704
	F8-45E-84-40MM	84	93	13	29-1/2	72-9/16	5/8	34-1/16	99-1/16	12	15	786
	F8-45E-96-40MM	96	105	13	33-1/2	82-1/8	5/8	36-7/8	110-7/16	12	15	865
	F8-45E-108-40MM	108	117	13	37-1/2	91-13/16	5/8	39-11/16	121-15/16	12	15	945
	F8-45E-120-40MM	120	129	13	41-1/2	101-7/16	5/8	42-1/2	133-1/2	12	15	1026

Also available in Aligners, Impacts, and Returns.

# CEMA F IDLERS

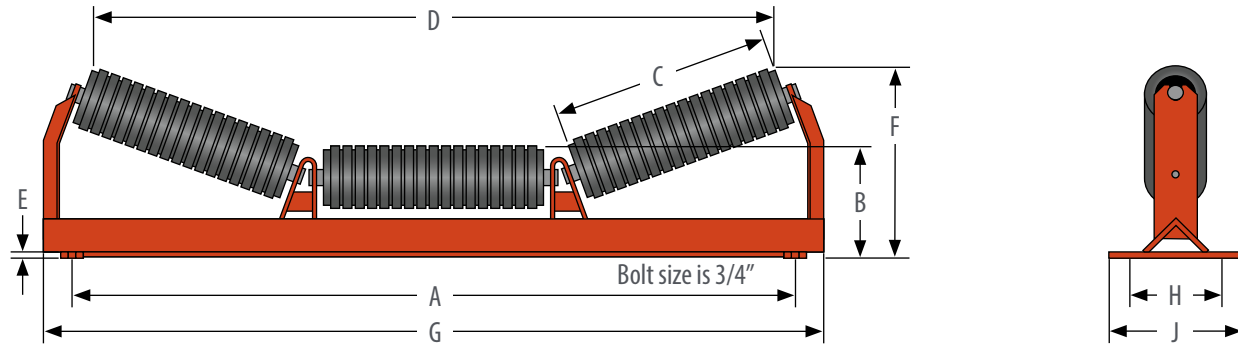

## RUBBER CUSHION IMPACT TROUGHING IDLERS: 7" AND 8" DIAMETER

	PART NUMBER		BW	B		C	D		E	F		G	H	J	WT (#)		
	7"	8"		7"	8"		7"	8"		7"	8"				7"	8"	
20°	F7-20EI-42-40MM	F8-20EI-42-40MM	42	51	12-1/2	13	14-3/4	45-3/4	45-3/8	5/8	17-13/16	18-5/16	56-7/16	12	15	362	385
	F7-20EI-48-40MM	F8-20EI-48-40MM	48	57	12-1/2	13	17-1/2	53-11/16	53-3/8	5/8	18-3/4	19-1/4	64-7/16	12	15	410	437
	F7-20EI-54-40MM	F8-20EI-54-40MM	54	63	12-1/2	13	19-1/2	45-3/4	59-1/16	5/8	17-3/4	19-15/16	70-1/16	12	15	447	476
	F7-20EI-60-40MM	F8-20EI-60-40MM	60	69	12-1/2	13	21-1/2	65-1/8	64-13/16	5/8	20-1/8	20-5/8	75-13/16	12	15	483	516
	F7-20EI-72-40MM	F8-20EI-72-40MM	72	81	12-1/2	13	25-1/2	76-3/4	76-7/16	5/8	21-1/2	22	87-7/16	12	15	556	595
	F7-20EI-84-40MM	F8-20EI-84-40MM	84	93	12-1/2	13	29-1/2	88-1/4	87-15/16	5/8	22-7/8	23-3/8	99-1/16	12	15	629	674
	F7-20EI-96-40MM	F8-20EI-96-40MM	96	105	12-1/2	13	33-1/2	99-3/4	99-3/8	5/8	24-1/4	24-11/16	110-7/16	12	15	702	753
	F7-20EI-108-40MM	F8-20EI-108-40MM	108	117	12-1/2	13	37-1/2	111-1/4	110-7/8	5/8	25-5/8	26-1/16	121-15/16	12	15	775	832
	F7-20EI-120-40MM	F8-20EI-120-40MM	120	129	12-1/2	13	41-1/2	122-3/4	122-7/16	5/8	27	27-7/16	133-1/2	12	15	848	911
	35°	F7-35EI-42-40MM	F8-35EI-42-40MM	42	51	12-1/2	13	14-3/4	40-13/16	40-1/4	5/8	21-1/4	21-5/8	56-7/16	12	15	369
F7-35EI-48-40MM		F8-35EI-48-40MM	48	57	12-1/2	13	17-1/2	48-1/8	47-9/16	5/8	22-13/16	23-1/4	64-7/16	12	15	418	444
F7-35EI-54-40MM		F8-35EI-54-40MM	54	63	12-1/2	13	19-1/2	53-5/16	52-3/4	5/8	23-15/16	24-3/8	70-1/16	12	15	455	484
F7-35EI-60-40MM		F8-35EI-60-40MM	60	69	12-1/2	13	21-1/2	58-9/16	58	5/8	25-1/8	25-1/2	75-13/16	12	15	492	524
F7-35EI-72-40MM		F8-35EI-72-40MM	72	81	12-1/2	13	25-1/2	69-1/4	68-5/8	5/8	27-7/16	27-13/16	87-7/16	12	15	566	604
F7-35EI-84-40MM		F8-35EI-84-40MM	84	93	12-1/2	13	29-1/2	79-13/16	79-3/16	5/8	29-11/16	30-1/8	99-1/16	12	15	640	684
F7-35EI-96-40MM		F8-35EI-96-40MM	96	105	12-1/2	13	33-1/2	90-1/4	89-11/16	5/8	32	32-7/16	110-7/16	12	15	714	764
F7-35EI-108-40MM		F8-35EI-108-40MM	108	117	12-1/2	13	37-1/2	100-13/16	100-1/4	5/8	34-5/16	34-11/16	121-15/16	12	15	788	844
F7-35EI-120-40MM		F8-35EI-120-40MM	120	129	12-1/2	13	41-1/2	111-3/8	110-13/16	5/8	36-9/16	37	133-1/2	12	15	862	924
45°		F7-45EI-42-40MM	F8-45EI-42-40MM	42	51	12-1/2	13	14-3/4	37-5/8	36-7/8	5/8	23-1/4	23-5/8	56-7/16	12	15	375
	F7-45EI-48-40MM	F8-45EI-48-40MM	48	57	12-1/2	13	17-1/2	44-5/16	43-9/16	5/8	25-3/16	25-9/16	64-7/16	12	15	425	451
	F7-45EI-54-40MM	F8-45EI-54-40MM	54	63	12-1/2	13	19-1/2	49	48-5/16	5/8	26-5/8	26-15/16	70-1/16	12	15	462	491
	F7-45EI-60-40MM	F8-45EI-60-40MM	60	69	12-1/2	13	21-1/2	53-7/8	53-1/8	5/8	28	28-3/8	75-13/16	12	15	499	532
	F7-45EI-72-40MM	F8-45EI-60-40MM	72	81	12-1/2	13	25-1/2	63-5/8	62-7/8	5/8	30-7/8	31-3/16	87-7/16	12	15	574	612
	F7-45EI-84-40MM	F8-45EI-84-40MM	84	93	12-1/2	13	29-1/2	73-1/4	72-9/16	5/8	33-11/16	34-1/16	99-1/16	12	15	650	694
	F7-45EI-96-40MM	F8-45EI-96-40MM	96	105	12-1/2	13	33-1/2	82-7/8	82-1/8	5/8	36-1/2	36-7/8	110-7/16	12	15	724	775
	F7-45EI-108-40MM	F8-45EI-108-40MM	108	117	12-1/2	13	37-1/2	92-1/2	91-13/16	5/8	39-5/16	39-11/16	121-15/16	12	15	799	855
	F7-45EI-120-40MM	F8-45EI-120-40MM	120	129	12-1/2	13	41-1/2	102-3/16	101-7/16	5/8	42-3/16	42-1/2	133-1/2	12	15	874	936

# CEMA F IDLERS

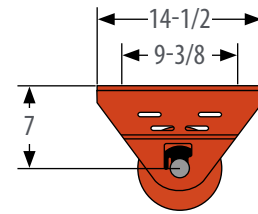
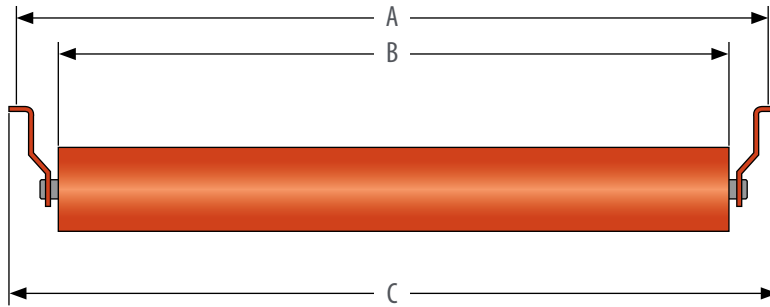

SLOTTED FOR 3/4" Ø BOLT

## RETURN IDLERS: 6", 7" AND 8" DIAMETER

PART NUMBER			BW	A	B	C	WT (#)		
6"	7"	8"					6"	7"	8"
F6-RET-42-40MM	F7-RET-42-40MM	F8-RET-42-40MM	42	51	45	53	176	224	262
F6-RET-48-40MM	F7-RET-48-40MM	F8-RET-48-40MM	48	57	51	59	197	248	288
F6-RET-54-40MM	F7-RET-54-40MM	F8-RET-54-40MM	54	63	57	65	218	272	315
F6-RET-60-40MM	F7-RET-60-40MM	F8-RET-60-40MM	60	69	63	71	240	296	342
F6-RET-72-40MM	F7-RET-72-40MM	F8-RET-72-40MM	72	81	75	83	282	344	395
F6-RET-84-40MM	F7-RET-84-40MM	F8-RET-84-40MM	84	93	87	95	325	392	448
F6-RET-96-40MM	F7-RET-96-40MM	F8-RET-96-40MM	96	105	99	107	368	440	501
F6-RET-108-40MM	F7-RET-108-40MM	F8-RET-108-40MM	108	117	111	119	410	488	555
F6-RET-120-40MM	F7-RET-120-40MM	F8-RET-120-40MM	120	129	123	131	453	536	608

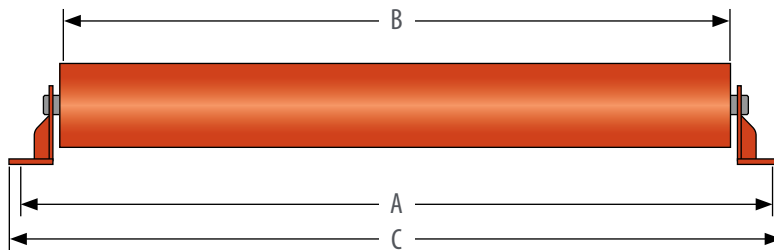

SLOTTED FOR 3/4" Ø BOLT

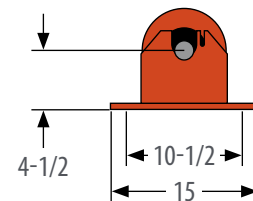

## FLAT IDLERS: 6", 7" AND 8" DIAMETER

PART NUMBER			BW	A	B	C	WT (#)		
6"	7"	8"					6"	7"	8"
F6-FLT-42-40MM	F7-FLT-42-40MM	F8-FLT-42-40MM	42	51	45	53	190	224	262
F6-FLT-48-40MM	F7-FLT-48-40MM	F8-FLT-48-40MM	48	57	51	59	211	248	288
F6-FLT-54-40MM	F7-FLT-54-40MM	F8-FLT-54-40MM	54	63	57	65	233	272	315
F6-FLT-60-40MM	F7-FLT-60-40MM	F8-FLT-60-40MM	60	69	63	71	254	296	342
F6-FLT-72-40MM	F7-FLT-72-40MM	F8-FLT-72-40MM	72	81	75	83	297	344	395
F6-FLT-84-40MM	F7-FLT-84-40MM	F8-FLT-84-40MM	84	93	87	95	339	392	448
F6-FLT-96-40MM	F7-FLT-96-40MM	F8-FLT-96-40MM	96	105	99	107	382	440	501
F6-FLT-108-40MM	F7-FLT-108-40MM	F8-FLT-108-40MM	108	117	111	119	425	488	555
F6-FLT-120-40MM	F7-FLT-120-40MM	F8-FLT-120-40MM	120	129	123	131	467	536	608

# CEMA F IDLERS

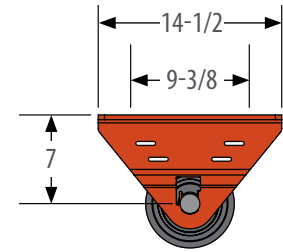
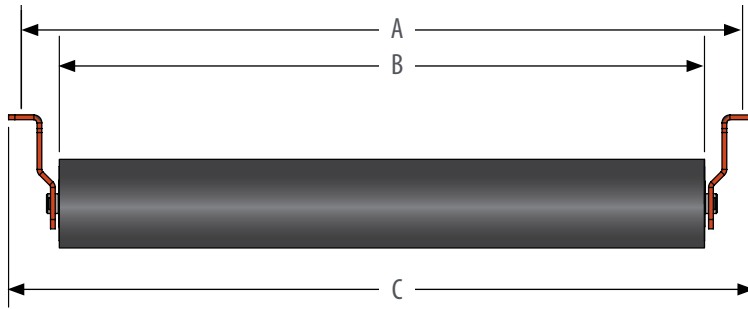

SLOTTED FOR 3/4" Ø BOLT

## RUBBER CUSHION RETURN IDLERS

PART NUMBER		BW	A	B	C	WT (#)	
7"	8"					7"	8"
F7-RETI-42-40MM	F8-RETI-42-40MM	42	51	45	53	244	304
F7-RETI-48-40MM	F8-RETI-48-40MM	48	57	51	59	270	336
F7-RETI-54-40MM	F8-RETI-54-40MM	54	63	57	65	297	368
F7-RETI-60-40MM	F8-RETI-60-40MM	60	69	63	71	323	401
F7-RETI-72-40MM	F8-RETI-72-40MM	72	81	75	83	377	465
F7-RETI-84-40MM	F8-RETI-84-40MM	84	93	87	95	430	529
F7-RETI-96-40MM	F8-RETI-96-40MM	96	105	99	107	483	594
F7-RETI-108-40MM	F8-RETI-108-40MM	108	117	111	119	536	659
F7-RETI-120-40MM	F8-RETI-120-40MM	120	129	123	131	589	723

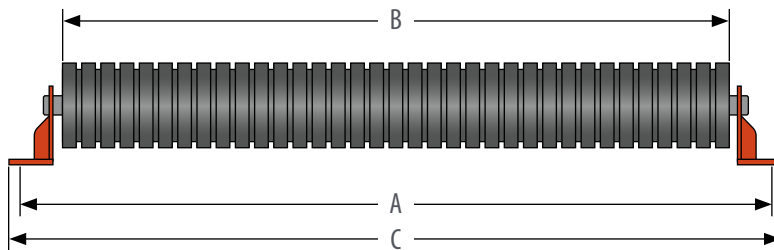

SLOTTED FOR 3/4" Ø BOLT

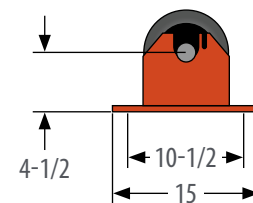

## RUBBER CUSHION FLAT IDLERS: 7" AND 8" DIAMETER

PART NUMBER		BW	A	B	C	WT (#)	
7"	8"					7"	8"
F7-FLTI-42-40MM	F8-FLTI-42-40MM	42	51	45	53	244	304
F7-FLTI-48-40MM	F8-FLTI-48-40MM	48	57	51	59	270	336
F7-FLTI-54-40MM	F8-FLTI-54-40MM	54	63	57	65	297	368
F7-FLTI-60-40MM	F8-FLTI-60-40MM	60	69	63	71	323	401
F7-FLTI-72-40MM	F8-FLTI-72-40MM	72	81	75	83	377	465
F7-FLTI-84-40MM	F8-FLTI-84-40MM	84	93	87	95	430	529
F7-FLTI-96-40MM	F8-FLTI-96-40MM	96	105	99	107	483	594
F7-FLTI-108-40MM	F8-FLTI-108-40MM	108	117	111	119	536	659
F7-FLTI-120-40MM	F8-FLTI-120-40MM	120	129	123	131	589	723

# CEMA F IDLERS

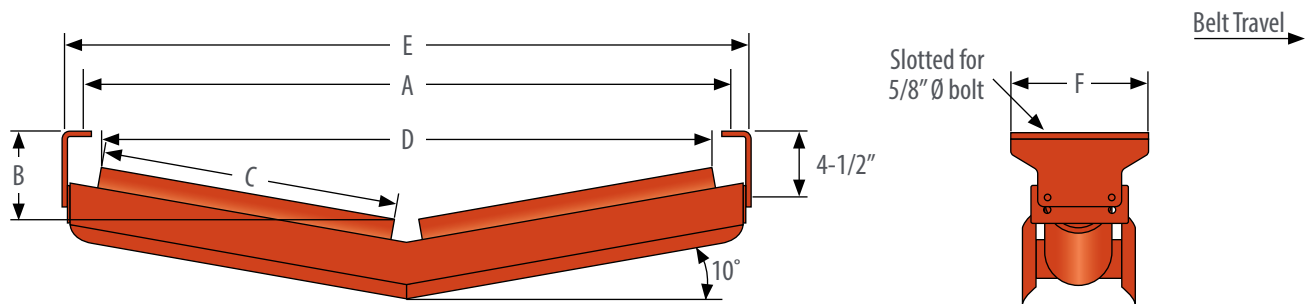

For wider base use next size larger belt width. Also available in 15°.

## V-RETURN IDLERS: 6", 7" AND 8" DIAMETER

PART NUMBER			BW	A	B			C	D			E	F	G	WT (#)		
6"	7"	8"			6"	7"	8"		6"	7"	8"				6"	7"	8"
F6-10RETV-42-40MM	F7-10RETV-42-40MM	F8-10RETV-42-40MM	42	51	8-1/16	7-9/16	7-1/6	22	45-5/8	46-1/2	46-5/16	54-1/2	16-1/8	14-1/2	308	356	410
F6-10RETV-48-40MM	F7-10RETV-48-40MM	F8-10RETV-48-40MM	48	57	8-5/8	8-1/8	7-11/16	25-1/2	52-5/8	52-1/2	52-5/16	60-1/2	16-5/8	14-1/2	341	393	450
F6-10RETV-54-40MM	F7-10RETV-54-40MM	F8-10RETV-54-40MM	54	63	9-3/16	8-11/16	8-3/16	28-1/2	58-5/8	58-1/2	58-5/16	66-1/2	17-1/8	14-1/2	371	425	485
F6-10RETV-60-40MM	F7-10RETV-60-40MM	F8-10RETV-60-40MM	60	69	9-11/16	9-3/16	8-11/16	31-1/2	64-5/8	64-1/2	64-5/16	72-1/2	17-11/16	14-1/2	400	457	520
F6-10RETV-72-40MM	F7-10RETV-72-40MM	F8-10RETV-72-40MM	72	81	10-3/4	10-1/4	9-3/4	37-1/2	76-5/8	76-1/2	76-5/16	84-1/2	18-3/4	14-1/2	459	522	589
F6-10RETV-84-40MM	F7-10RETV-84-40MM	F8-10RETV-84-40MM	84	93	11-3/4	11-1/4	10-13/16	43-1/2	88-5/8	88-1/2	88-5/16	96-1/2	19-13/16	14-1/2	519	586	659
F6-10RETV-96-40MM	F7-10RETV-96-40MM	F8-10RETV-96-40MM	96	105	12-7/8	12-3/8	11-15/16	50	100-5/8	100-1/2	100-5/16	108-1/2	20-7/8	14-1/2	581	655	734
F6-10RETV-108-40MM	F7-10RETV-108-40MM	F8-10RETV-108-40MM	108	117	13-7/8	13-3/8	12-7/8	55-1/2	112-5/8	112-1/2	112-5/16	120-1/2	21-15/16	14-1/2	637	715	799
F6-10RETV-120-40MM	F7-10RETV-120-40MM	F8-10RETV-120-40MM	120	129	14-7/8	14-3/8	13-15/16	61-1/2	124-5/8	124-1/2	124-5/16	132-1/2	23	14-1/2	696	780	869

# 50DT IDLERS

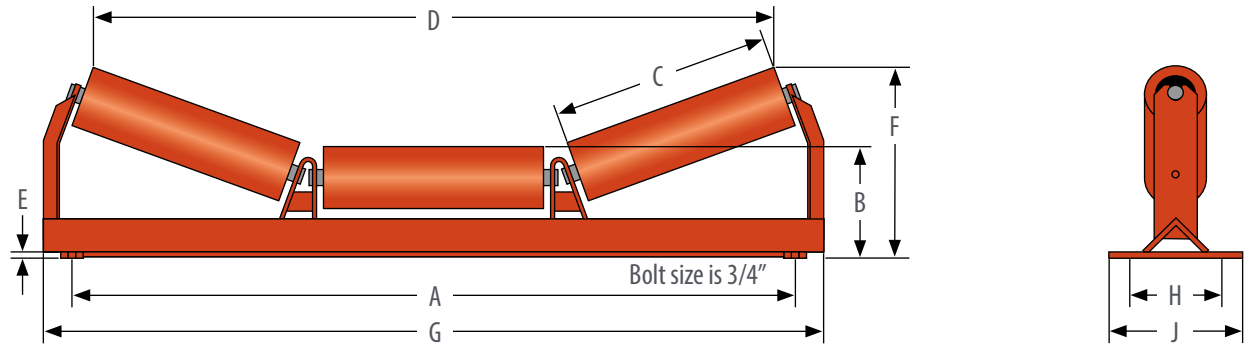

## TROUGHING IDLERS (EQUAL LENGTH ROLLERS): 6" DIAMETER

	PART NUMBER	BW	A	B	C	D	E	F	G	H	J	WT (#)
20°	F6-20E-42-50DT	42	51	12	14-3/4	46-1/16	5/8	17-3/8	56-7/16	12	15	344
	F6-20E-48-50DT	48	57	12	17-1/2	54-1/16	5/8	18-5/16	64-7/16	12	15	388
	F6-20E-54-50DT	54	63	12	19-1/2	59-11/16	5/8	19	70-1/16	12	15	422
	F6-20E-60-50DT	60	69	12	21-1/2	65-1/2	5/8	19-11/16	75-13/16	12	15	456
	F6-20E-72-50DT	72	81	12	25-1/2	77-1/16	5/8	21-1/16	87-7/16	12	15	523
	F6-20E-84-50DT	84	93	12	29-1/2	88-5/8	5/8	22-7/16	99-1/16	12	15	591
	F6-20E-96-50DT	96	105	12	33-1/2	100-1/16	5/8	23-3/4	110-7/16	12	15	659
	F6-20E-108-50DT	108	117	12	37-1/2	111-9/16	5/8	25-1/8	121-15/16	12	15	727
35°	F6-20E-120-50DT	120	129	12	41-1/2	123-1/8	5/8	26-1/2	133-1/2	12	15	794
	F6-35E-42-50DT	42	51	12	14-3/4	41-3/8	5/8	20-13/16	56-7/16	12	15	350
	F6-35E-48-50DT	48	57	12	17-1/2	48-11/16	5/8	22-7/16	64-7/16	12	15	395
	F6-35E-54-50DT	54	63	12	19-1/2	53-7/8	5/8	23-9/16	70-1/16	12	15	430
	F6-35E-60-50DT	60	69	12	21-1/2	59-1/8	5/8	24-11/16	75-13/16	12	15	464
	F6-35E-72-50DT	72	81	12	25-1/2	69-13/16	5/8	27	87-7/16	12	15	533
	F6-35E-84-50DT	84	93	12	29-1/2	80-3/8	5/8	29-5/16	99-1/16	12	15	602
	F6-35E-96-50DT	96	105	12	33-1/2	90-7/8	5/8	31-9/16	110-7/16	12	15	700
45°	F6-35E-108-50DT	108	117	12	37-1/2	101-3/8	5/8	33-7/8	121-15/16	12	15	739
	F6-35E-120-50DT	120	129	12	41-1/2	111-15/16	5/8	36-3/16	133-1/2	12	15	808
	F6-45E-42-50DT	42	51	12	14-3/4	38-5/16	5/8	22-7/8	56-7/16	12	15	357
	F6-45E-48-50DT	48	57	12	17-1/2	45	5/8	24-7/8	64-7/16	12	15	403
	F6-45E-54-50DT	54	63	12	19-1/2	49-3/4	5/8	26-1/4	70-1/16	12	15	437
	F6-45E-60-50DT	60	69	12	21-1/2	54-9/16	5/8	27-11/16	75-13/16	12	15	472
	F6-45E-72-50DT	72	81	12	25-1/2	64-5/16	5/8	30-1/2	87-7/16	12	15	541
	F6-45E-84-50DT	84	93	12	29-1/2	73-15/16	5/8	33-5/16	99-1/16	12	15	611
F6-45E-96-50DT	96	105	12	33-1/2	83-9/16	5/8	36-3/16	110-7/16	12	15	680	
F6-45E-108-50DT	108	117	12	37-1/2	93-1/4	5/8	39	121-15/16	12	15	750	
F6-45E-120-50DT	120	129	12	41-1/2	102-7/8	5/8	41-13/16	133-1/2	12	15	820	

# 50DT IDLERS

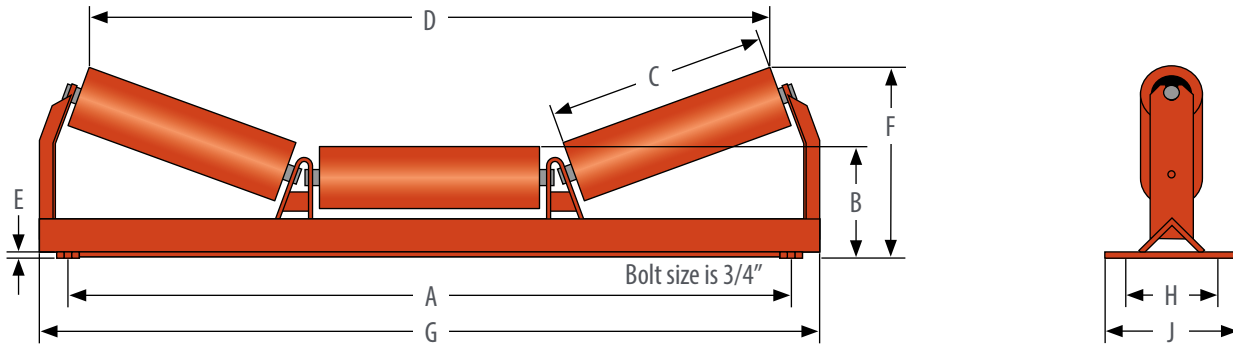

## TROUGHING IDLERS (EQUAL LENGTH ROLLERS): 7" DIAMETER

	PART NUMBER	BW	A	B	C	D	E	F	G	H	J	WT (#)
20°	F7-20E-42-50DT	42	51	12-1/2	14-3/4	45-3/4	5/8	17-13/16	56-7/16	12	15	407
	F7-20E-48-50DT	48	57	12-1/2	17-1/2	53-11/16	5/8	18-3/4	64-7/16	12	15	455
	F7-20E-54-50DT	54	63	12-1/2	19-1/2	45-3/4	5/8	17-3/4	70-1/16	12	15	491
	F7-20E-60-50DT	60	69	12-1/2	21-1/2	65-1/8	5/8	20-1/8	75-13/16	12	15	528
	F7-20E-72-50DT	72	81	12-1/2	25-1/2	76-3/4	5/8	21-1/2	87-7/16	12	15	601
	F7-20E-84-50DT	84	93	12-1/2	29-1/2	88-1/4	5/8	22-7/8	99-1/16	12	15	674
	F7-20E-96-50DT	96	105	12-1/2	33-1/2	99-3/4	5/8	24-1/4	110-7/16	12	15	747
	F7-20E-108-50DT	108	117	12-1/2	37-1/2	111-1/4	5/8	25-5/8	121-15/16	12	15	820
F7-20E-120-50DT	120	129	12-1/2	41-1/2	122-3/4	5/8	27	133-1/2	12	15	893	
35°	F7-35E-42-50DT	42	51	12-1/2	14-3/4	40-13/16	5/8	21-1/4	56-7/16	12	15	414
	F7-35E-48-50DT	48	57	12-1/2	17-1/2	48-1/8	5/8	22-13/16	64-7/16	12	15	462
	F7-35E-54-50DT	54	63	12-1/2	19-1/2	53-5/16	5/8	23-15/16	70-1/16	12	15	499
	F7-35E-60-50DT	60	69	12-1/2	21-1/2	58-9/16	5/8	25-1/8	75-13/16	12	15	536
	F7-35E-72-50DT	72	81	12-1/2	25-1/2	69-1/4	5/8	27-7/16	87-7/16	12	15	610
	F7-35E-84-50DT	84	93	12-1/2	29-1/2	79-13/16	5/8	29-11/16	99-1/16	12	15	685
	F7-35E-96-50DT	96	105	12-1/2	33-1/2	90-1/4	5/8	32	110-7/16	12	15	759
	F7-35E-108-50DT	108	117	12-1/2	37-1/2	100-13/16	5/8	34-5/16	121-15/16	12	15	833
F7-35E-120-50DT	120	129	12-1/2	41-1/2	111-3/8	5/8	36-9/16	133-1/2	12	15	907	
45°	F7-45E-42-50DT	42	51	12-1/2	14-3/4	37-5/8	5/8	23-1/4	56-7/16	12	15	420
	F7-45E-48-50DT	48	57	12-1/2	17-1/2	44-5/16	5/8	25-3/16	64-7/16	12	15	469
	F7-45E-54-50DT	54	63	12-1/2	19-1/2	49	5/8	26-5/8	70-1/16	12	15	507
	F7-45E-60-50DT	60	69	12-1/2	21-1/2	53-7/8	5/8	28	75-13/16	12	15	544
	F7-45E-72-50DT	72	81	12-1/2	25-1/2	63-5/8	5/8	30-7/8	87-7/16	12	15	619
	F7-45E-84-50DT	84	93	12-1/2	29-1/2	73-1/4	5/8	33-11/16	99-1/16	12	15	694
	F7-45E-96-50DT	96	105	12-1/2	33-1/2	82-7/8	5/8	36-1/2	110-7/16	12	15	768
	F7-45E-108-50DT	108	117	12-1/2	37-1/2	92-1/2	5/8	39-5/16	121-15/16	12	15	844
F7-45E-120-50DT	120	129	12-1/2	41-1/2	102-3/16	5/8	42-3/16	133-1/2	12	15	919	



# 50DT IDLERS

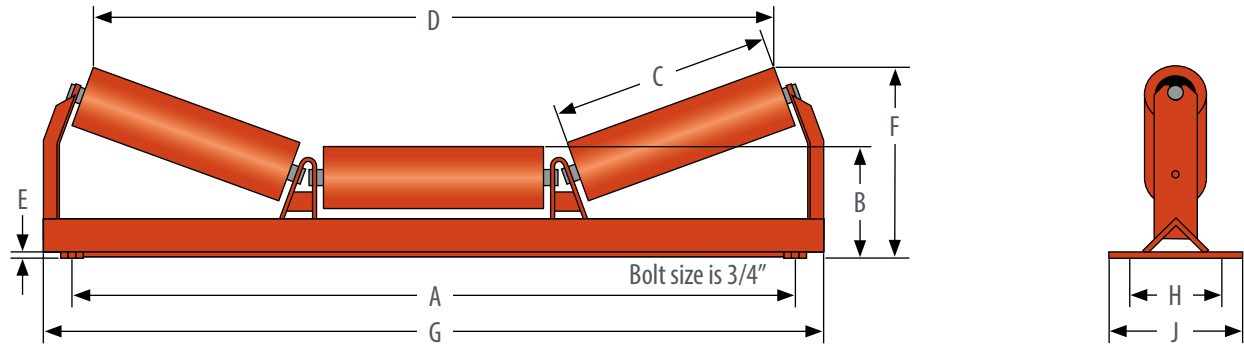

## TROUGHING IDLERS (EQUAL LENGTH ROLLERS): 8" DIAMETER

	PART NUMBER	BW	A	B	C	D	E	F	G	H	J	WT (#)
20°	F8-20E-42-50DT	42	51	13	14-3/4	45-3/8	5/8	18-5/16	56-7/16	12	15	478
	F8-20E-48-50DT	48	57	13	17-1/2	53-3/8	5/8	19-1/4	64-7/16	12	15	530
	F8-20E-54-50DT	54	63	13	19-1/2	59-1/16	5/8	19-15/16	70-1/16	12	15	569
	F8-20E-60-50DT	60	69	13	21-1/2	64-13/16	5/8	20-5/8	75-13/16	12	15	608
	F8-20E-72-50DT	72	81	13	25-1/2	76-7/16	5/8	22	87-7/16	12	15	687
	F8-20E-84-50DT	84	93	13	29-1/2	87-15/16	5/8	23-3/8	99-1/16	12	15	765
	F8-20E-96-50DT	96	105	13	33-1/2	99-3/8	5/8	24-11/16	110-7/16	12	15	843
	F8-20E-108-50DT	108	117	13	37-1/2	110-7/8	5/8	26-1/16	121-15/16	12	15	922
35°	F8-20E-120-50DT	120	129	13	41-1/2	122-7/16	5/8	27-7/16	133-1/2	12	15	1000
	F8-35E-42-50DT	42	51	13	14-3/4	40-1/4	5/8	21-5/8	56-7/16	12	15	485
	F8-35E-48-50DT	48	57	13	17-1/2	47-9/16	5/8	23-1/4	64-7/16	12	15	537
	F8-35E-54-50DT	54	63	13	19-1/2	52-3/4	5/8	24-3/8	70-1/16	12	15	577
	F8-35E-60-50DT	60	69	13	21-1/2	58	5/8	25-1/2	75-13/16	12	15	617
	F8-35E-72-50DT	72	81	13	25-1/2	68-5/8	5/8	27-13/16	87-7/16	12	15	696
	F8-35E-84-50DT	84	93	13	29-1/2	79-3/16	5/8	30-1/8	99-1/16	12	15	775
	F8-35E-96-50DT	96	105	13	33-1/2	89-11/16	5/8	32-7/16	110-7/16	12	15	855
45°	F8-35E-108-50DT	108	117	13	37-1/2	100-1/4	5/8	34-11/16	121-15/16	12	15	934
	F8-35E-120-50DT	120	129	13	41-1/2	110-13/16	5/8	37	133-1/2	12	15	1014
	F8-45E-42-50DT	42	51	13	14-3/4	36-7/8	5/8	23-5/8	56-7/16	12	15	491
	F8-45E-48-50DT	48	57	13	17-1/2	43-9/16	5/8	25-9/16	64-7/16	12	15	544
	F8-45E-54-50DT	54	63	13	19-1/2	48-5/16	5/8	26-15/16	70-1/16	12	15	584
	F8-45E-60-50DT	60	69	13	21-1/2	53-1/8	5/8	28-3/8	75-13/16	12	15	624
	F8-45E-72-50DT	72	81	13	25-1/2	62-7/8	5/8	31-3/16	87-7/16	12	15	704
	F8-45E-84-50DT	84	93	13	29-1/2	72-9/16	5/8	34-1/16	99-1/16	12	15	786
F8-45E-96-50DT	96	105	13	33-1/2	82-1/8	5/8	36-7/8	110-7/16	12	15	865	
F8-45E-108-50DT	108	117	13	37-1/2	91-13/16	5/8	39-11/16	121-15/16	12	15	945	
F8-45E-120-50DT	120	129	13	41-1/2	101-7/16	5/8	42-1/2	133-1/2	12	15	1026	

# 50DT IDLERS

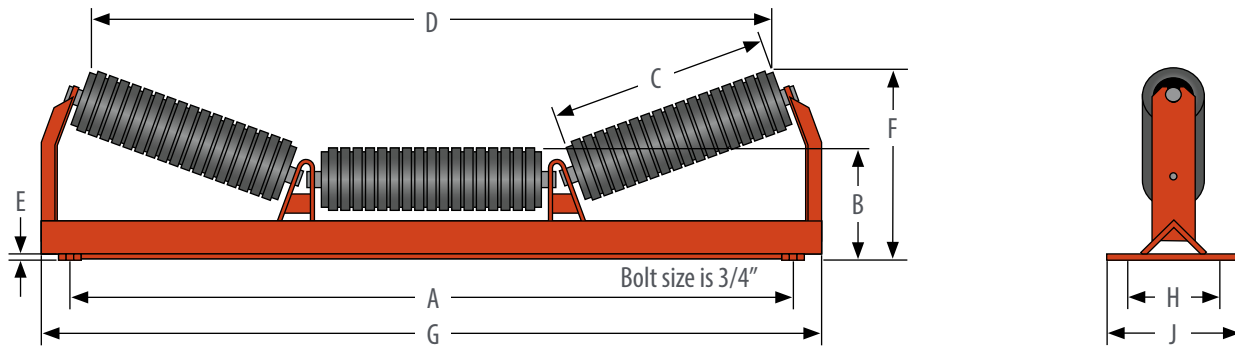

## RUBBER CUSHION IMPACT TROUGHING IDLERS: 7" AND 8" DIAMETER

	PART NUMBER		BW	A		B		C		D		E	F		G	H		J	WT (#)	
	7"	8"		7"	8"	7"	8"	7"	8"	7"	8"		7"	8"		7"	8"			
20°	F7-20E-42-50DT	F8-20E-42-50DT	42	51	12-1/2	13	14-3/4	45-3/4	45-3/8	5/8	17-13/16	18-5/16	56-7/16	12	15	407	478			
	F7-20E-48-50DT	F8-20E-48-50DT	48	57	12-1/2	13	17-1/2	53-11/16	53-3/8	5/8	18-3/4	19-1/4	64-7/16	12	15	455	530			
	F7-20E-54-50DT	F8-20E-54-50DT	54	63	12-1/2	13	19-1/2	45-3/4	59-1/16	5/8	17-3/4	19-15/16	70-1/16	12	15	491	569			
	F7-20E-60-50DT	F8-20E-60-50DT	60	69	12-1/2	13	21-1/2	65-1/8	64-13/16	5/8	20-1/8	20-5/8	75-13/16	12	15	528	608			
	F7-20E-72-50DT	F8-20E-72-50DT	72	81	12-1/2	13	25-1/2	76-3/4	76-7/16	5/8	21-1/2	22	87-7/16	12	15	601	687			
	F7-20E-84-50DT	F8-20E-84-50DT	84	93	12-1/2	13	29-1/2	88-1/4	87-15/16	5/8	22-7/8	23-3/8	99-1/16	12	15	674	765			
	F7-20E-96-50DT	F8-20E-96-50DT	96	105	12-1/2	13	33-1/2	99-3/4	99-3/8	5/8	24-1/4	24-11/16	110-7/16	12	15	747	843			
	F7-20E-108-50DT	F8-20E-108-50DT	108	117	12-1/2	13	37-1/2	111-1/4	110-7/8	5/8	25-5/8	26-1/16	121-15/16	12	15	820	922			
	F7-20E-120-50DT	F8-20E-120-50DT	120	129	12-1/2	13	41-1/2	122-3/4	122-7/16	5/8	27	27-7/16	133-1/2	12	15	893	1000			
	35°	F7-35E-42-50DT	F8-35E-42-50DT	42	51	12-1/2	13	14-3/4	40-13/16	40-1/4	5/8	21-1/4	21-5/8	56-7/16	12	15	414	485		
F7-35E-48-50DT		F8-35E-48-50DT	48	57	12-1/2	13	17-1/2	48-1/8	47-9/16	5/8	22-13/16	23-1/4	64-7/16	12	15	462	537			
F7-35E-54-50DT		F8-35E-54-50DT	54	63	12-1/2	13	19-1/2	53-5/16	52-3/4	5/8	23-15/16	24-3/8	70-1/16	12	15	499	577			
F7-35E-60-50DT		F8-35E-60-50DT	60	69	12-1/2	13	21-1/2	58-9/16	58	5/8	25-1/8	25-1/2	75-13/16	12	15	536	617			
F7-35E-72-50DT		F8-35E-72-50DT	72	81	12-1/2	13	25-1/2	69-1/4	68-5/8	5/8	27-7/16	27-13/16	87-7/16	12	15	610	696			
F7-35E-84-50DT		F8-35E-84-50DT	84	93	12-1/2	13	29-1/2	79-13/16	79-3/16	5/8	29-11/16	30-1/8	99-1/16	12	15	685	775			
F7-35E-96-50DT		F8-35E-96-50DT	96	105	12-1/2	13	33-1/2	90-1/4	89-11/16	5/8	32	32-7/16	110-7/16	12	15	759	855			
F7-35E-108-50DT		F8-35E-108-50DT	108	117	12-1/2	13	37-1/2	100-13/16	100-1/4	5/8	34-5/16	34-11/16	121-15/16	12	15	833	934			
F7-35E-120-50DT		F8-35E-120-50DT	120	129	12-1/2	13	41-1/2	111-3/8	110-13/16	5/8	36-9/16	37	133-1/2	12	15	907	1014			
45°		F7-45E-42-50DT	F8-45E-42-50DT	42	51	12-1/2	13	14-3/4	37-5/8	36-7/8	5/8	23-1/4	23-5/8	56-7/16	12	15	420	491		
	F7-45E-48-50DT	F8-45E-48-50DT	48	57	12-1/2	13	17-1/2	44-5/16	43-9/16	5/8	25-3/16	25-9/16	64-7/16	12	15	469	544			
	F7-45E-54-50DT	F8-45E-54-50DT	54	63	12-1/2	13	19-1/2	49	48-5/16	5/8	26-5/8	26-15/16	70-1/16	12	15	507	584			
	F7-45E-60-50DT	F8-45E-60-50DT	60	69	12-1/2	13	21-1/2	53-7/8	53-1/8	5/8	28	28-3/8	75-13/16	12	15	544	624			
	F7-45E-72-50DT	F8-45E-72-50DT	72	81	12-1/2	13	25-1/2	63-5/8	62-7/8	5/8	30-7/8	31-3/16	87-7/16	12	15	619	704			
	F7-45E-84-50DT	F8-45E-84-50DT	84	93	12-1/2	13	29-1/2	73-1/4	72-9/16	5/8	33-11/16	34-1/16	99-1/16	12	15	694	786			
	F7-45E-96-50DT	F8-45E-96-50DT	96	105	12-1/2	13	33-1/2	82-7/8	82-1/8	5/8	36-1/2	36-7/8	110-7/16	12	15	768	865			
	F7-45E-108-50DT	F8-45E-108-50DT	108	117	12-1/2	13	37-1/2	92-1/2	91-13/16	5/8	39-5/16	39-11/16	121-15/16	12	15	844	945			
	F7-45E-120-50DT	F8-45E-120-50DT	120	129	12-1/2	13	41-1/2	102-3/16	101-7/16	5/8	42-3/16	42-1/2	133-1/2	12	15	919	1026			

# 50DT IDLERS

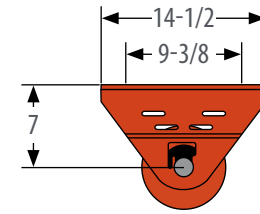
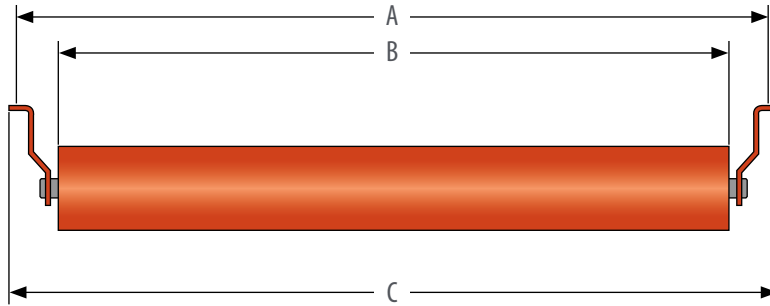

SLOTTED FOR 3/4" Ø BOLT

## RETURN IDLERS: 6", 7" AND 8" DIAMETER

PART NUMBER			BW	A	B	C	WT (#)		
6"	7"	8"					6"	7"	8"
F6-RET-42-50DT	F7-RET-42-50DT	F8-RET-42-50DT	42	51	45	53	176	210	247
F6-RET-48-50DT	F7-RET-48-50DT	F8-RET-48-50DT	48	57	51	59	197	234	274
F6-RET-54-50DT	F7-RET-54-50DT	F8-RET-54-50DT	54	63	57	65	218	258	300
F6-RET-60-50DT	F7-RET-60-50DT	F8-RET-60-50DT	60	69	63	71	240	282	327
F6-RET-72-50DT	F7-RET-72-50DT	F8-RET-72-50DT	72	81	75	83	282	330	380
F6-RET-84-50DT	F7-RET-84-50DT	F8-RET-84-50DT	84	93	87	95	325	378	434
F6-RET-96-50DT	F7-RET-96-50DT	F8-RET-96-50DT	96	105	99	107	368	426	487
F6-RET-108-50DT	F7-RET-108-50DT	F8-RET-108-50DT	108	117	111	119	410	474	540
F6-RET-120-50DT	F7-RET-120-50DT	F8-RET-120-50DT	120	129	123	131	453	522	594

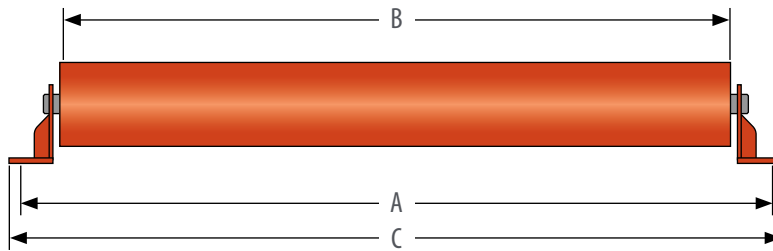

SLOTTED FOR 3/4" Ø BOLT

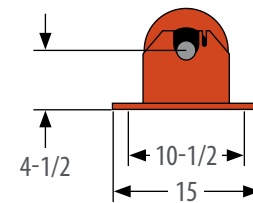

## FLAT IDLERS: 6", 7" AND 8" DIAMETER

PART NUMBER			BW	A	B	C	WT (#)		
6"	7"	8"					6"	7"	8"
F6-FLT-42-50DT	F7-FLT-42-50DT	F8-FLT-42-50DT	42	51	45	53	190	224	262
F6-FLT-48-50DT	F7-FLT-48-50DT	F8-FLT-48-50DT	48	57	51	59	211	248	288
F6-FLT-54-50DT	F7-FLT-54-50DT	F8-FLT-54-50DT	54	63	57	65	233	272	315
F6-FLT-60-50DT	F7-FLT-60-50DT	F8-FLT-60-50DT	60	69	63	71	254	296	342
F6-FLT-72-50DT	F7-FLT-72-50DT	F8-FLT-72-50DT	72	81	75	83	297	344	395
F6-FLT-84-50DT	F7-FLT-84-50DT	F8-FLT-84-50DT	84	93	87	95	339	392	448
F6-FLT-96-50DT	F7-FLT-96-50DT	F8-FLT-96-50DT	96	105	99	107	382	440	501
F6-FLT-108-50DT	F7-FLT-108-50DT	F8-FLT-108-50DT	108	117	111	119	425	488	555
F6-FLT-120-50DT	F7-FLT-120-50DT	F8-FLT-120-50DT	120	129	123	131	467	536	608

# 50DT IDLERS

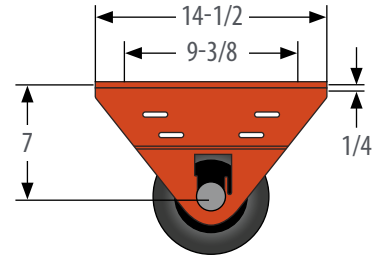
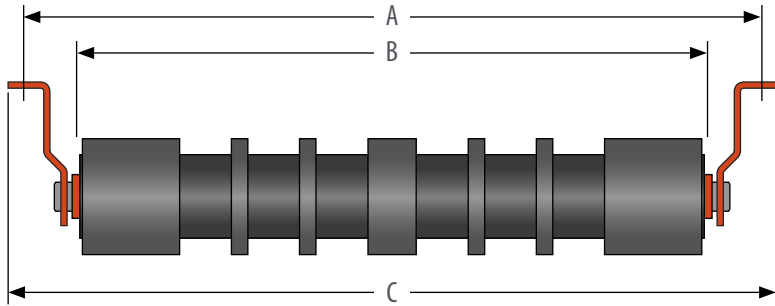

SLOTTED FOR 3/4" Ø BOLT

## RUBBER CUSHION RETURN IDLERS: 7" AND 8" DIAMETER

PART NUMBER		BW	A	B	C	WT (#)	
7"	8"					7"	8"
F7-RETI-42-50DT	F8-RETI-42-50DT	42	51	45	53	244	304
F7-RETI-48-50DT	F8-RETI-48-50DT	48	57	51	59	270	336
F7-RETI-54-50DT	F8-RETI-54-50DT	54	63	57	65	297	368
F7-RETI-60-50DT	F8-RETI-60-50DT	60	69	63	71	323	401
F7-RETI-72-50DT	F8-RETI-72-50DT	72	81	75	83	377	465
F7-RETI-84-50DT	F8-RETI-84-50DT	84	93	87	95	430	529
F7-RETI-96-50DT	F8-RETI-96-50DT	96	105	99	107	483	594
F7-RETI-108-50DT	F8-RETI-108-50DT	108	117	111	119	536	659
F7-RETI-120-50DT	F8-RETI-120-50DT	120	129	123	131	589	723

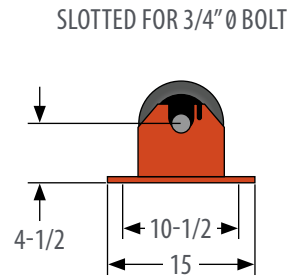
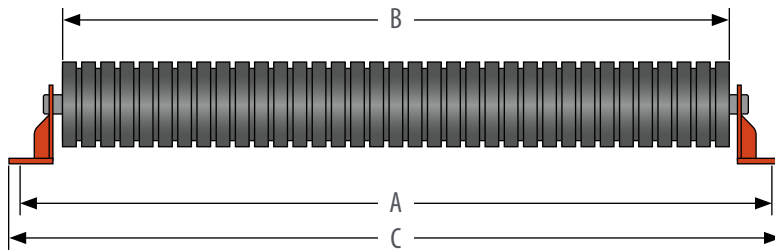

## RUBBER CUSHION FLAT IDLERS: 7" AND 8" DIAMETER

PART NUMBER		BW	A	B	C	WT (#)	
7"	8"					7"	8"
F7-FLTI-42-50DT	F8-FLTI-42-50DT	42	51	45	53	244	304
F7-FLTI-48-50DT	F8-FLTI-48-50DT	48	57	51	59	270	336
F7-FLTI-54-50DT	F8-FLTI-54-50DT	54	63	57	65	297	368
F7-FLTI-60-50DT	F8-FLTI-60-50DT	60	69	63	71	323	401
F7-FLTI-72-50DT	F8-FLTI-72-50DT	72	81	75	83	377	465
F7-FLTI-84-50DT	F8-FLTI-84-50DT	84	93	87	95	430	529
F7-FLTI-96-50DT	F8-FLTI-96-50DT	96	105	99	107	483	594
F7-FLTI-108-50DT	F8-FLTI-108-50DT	108	117	111	119	536	659
F7-FLTI-120-50DT	F8-FLTI-120-50DT	120	129	123	131	589	723

# 50DT IDLERS

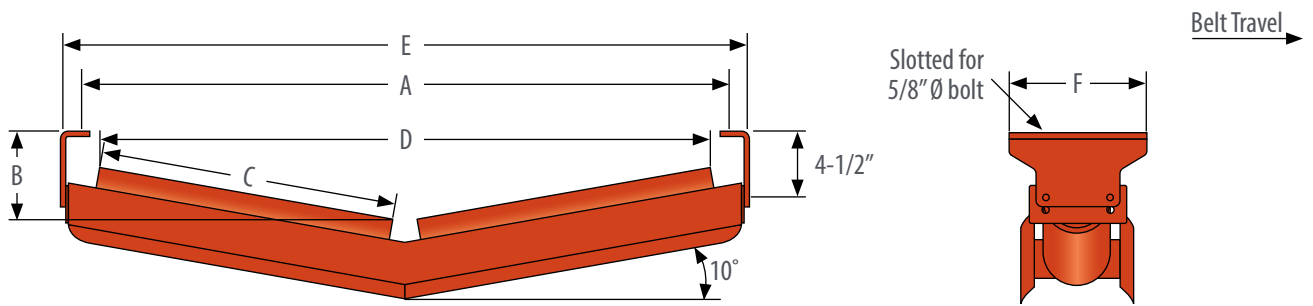

For wider base use next size larger belt width. Also available in 15°.

## V-RETURN IDLERS: 6", 7" AND 8" DIAMETER

PART NUMBER			BW	A	B			C	D			E	F	G	WT (#)		
6"	7"	8"			6"	7"	8"		6"	7"	8"				6"	7"	8"
F6-10RETV-42-50DT	F7-10RETV-42-50DT	F8-10RETV-42-50DT	42	51	8-1/16	7-9/16	7-1/6	22	45-5/8	46-1/2	46-5/16	54-1/2	16-1/8	14-1/2	308	356	410
F6-10RETV-48-50DT	F7-10RETV-48-50DT	F8-10RETV-48-50DT	48	57	8-5/8	8-1/8	7-11/16	25-1/2	52-5/8	52-1/2	52-5/16	60-1/2	16-5/8	14-1/2	341	393	450
F6-10RETV-54-50DT	F7-10RETV-54-50DT	F8-10RETV-54-50DT	54	63	9-3/16	8-11/16	8-3/16	28-1/2	58-5/8	58-1/2	58-5/16	66-1/2	17-1/8	14-1/2	371	425	485
F6-10RETV-60-50DT	F7-10RETV-60-50DT	F8-10RETV-60-50DT	60	69	9-11/16	9-3/16	8-11/16	31-1/2	64-5/8	64-1/2	64-5/16	72-1/2	17-11/16	14-1/2	400	457	520
F6-10RETV-72-50DT	F7-10RETV-72-50DT	F8-10RETV-72-50DT	72	81	10-3/4	10-1/4	9-3/4	37-1/2	76-5/8	76-1/2	76-5/16	84-1/2	18-3/4	14-1/2	459	522	589
F6-10RETV-84-50DT	F7-10RETV-84-50DT	F8-10RETV-84-50DT	84	93	11-3/4	11-1/4	10-13/16	43-1/2	88-5/8	88-1/2	88-5/16	96-1/2	19-13/16	14-1/2	519	586	659
F6-10RETV-96-50DT	F7-10RETV-96-50DT	F8-10RETV-96-50DT	96	105	12-7/8	12-3/8	11-15/16	50	100-5/8	100-1/2	100-5/16	108-1/2	20-7/8	14-1/2	581	655	734
F6-10RETV-108-50DT	F7-10RETV-108-50DT	F8-10RETV-108-50DT	108	117	13-7/8	13-3/8	12-7/8	55-1/2	112-5/8	112-1/2	112-5/16	120-1/2	21-15/16	14-1/2	637	715	799
F6-10RETV-120-50DT	F7-10RETV-120-50DT	F8-10RETV-120-50DT	120	129	14-7/8	14-3/8	13-15/16	61-1/2	124-5/8	124-1/2	124-5/16	132-1/2	23	14-1/2	696	780	869

# 60DT IDLERS

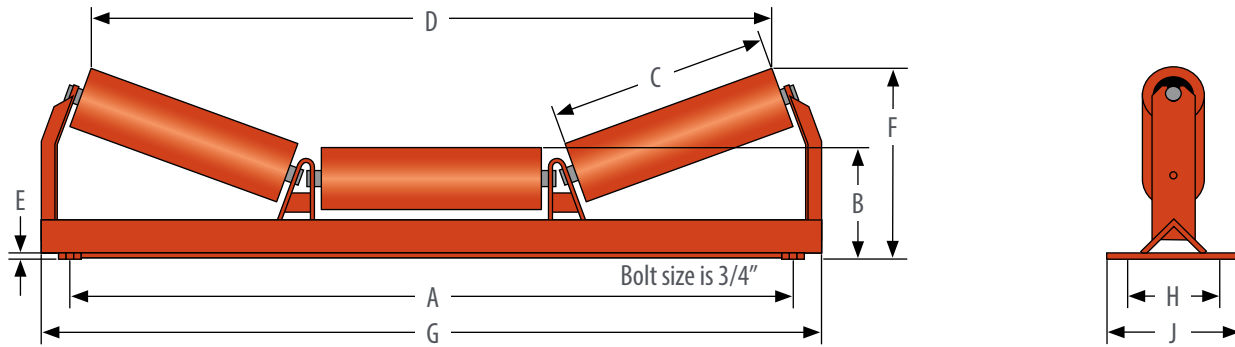

## TROUGHING IDLERS (EQUAL LENGTH ROLLERS): 7" AND 8" DIAMETER

PART NUMBER		BW	A	B		C	D		E	F		G	H	J	WT (#)		
7"	8"			7"	8"		7"	8"		7"	8"				7"	8"	7"
20°	G7-20E-60-60DT	G8-20E-60-60DT	60	69	12-1/2	13	21-1/2	65-5/8	65-1/4	5/8	20-3/16	20-5/8	76-9/16	12	15	510	526
	G7-20E-72-60DT	G8-20E-72-60DT	72	81	12-1/2	13	25-1/2	77-3/16	76-13/16	5/8	21-9/16	22	88-3/16	12	15	580	599
	G7-20E-84-60DT	G8-20E-84-60DT	84	93	12-1/2	13	29-1/2	88-11/16	88-5/16	5/8	22-15/16	23-3/8	99-13/16	12	15	651	673
	G7-20E-96-60DT	G8-20E-96-60DT	96	105	12-1/2	13	33-1/2	100-1/8	99-13/16	5/8	24-5/16	24-3/4	111-3/16	12	15	722	746
	G7-20E-108-60DT	G8-20E-108-60DT	108	117	12-1/2	13	37-1/2	111-11/16	111-3/8	5/8	25-5/8	26-1/8	122-11/16	12	15	793	820
	G7-20E-120-60DT	G8-20E-120-60DT	120	129	12-1/2	13	41-1/2	123-1/4	122-7/8	5/8	27	27-1/2	134-1/4	12	15	864	894
35°	G7-35E-60-60DT	G8-35E-60-60DT	60	69	12-1/2	13	21-1/2	59	58-7/16	5/8	25-3/16	25-9/16	76-9/16	12	15	523	539
	G7-35E-72-60DT	G8-35E-72-60DT	72	81	12-1/2	13	25-1/2	69-5/8	69	5/8	27-1/2	27-7/8	88-3/16	12	15	594	613
	G7-35E-84-60DT	G8-35E-84-60DT	84	93	12-1/2	13	29-1/2	80-1/8	79-9/16	5/8	29-3/4	30-3/16	99-13/16	12	15	667	689
	G7-35E-96-60DT	G8-35E-96-60DT	96	105	12-1/2	13	33-1/2	90-5/8	90-1/16	5/8	32-1/16	32-1/2	111-3/16	12	15	739	763
	G7-35E-108-60DT	G8-35E-108-60DT	108	117	12-1/2	13	37-1/2	101-1/4	100-11/16	5/8	34-3/8	34-3/4	122-11/16	12	15	812	839
	G7-35E-120-60DT	G8-35E-120-60DT	120	129	12-1/2	13	41-1/2	111-13/16	111-1/4	5/8	36-5/8	37-1/16	134-1/4	12	15	884	914
45°	G7-45E-60-60DT	G8-45E-60-60DT	60	69	12-1/2	13	21-1/2	54-1/4	53-9/16	5/8	28-1/8	28-7/16	76-9/16	12	15	535	551
	G7-45E-72-60DT	G8-45E-72-60DT	72	81	12-1/2	13	25-1/2	63-15/16	63-1/4	5/8	30-15/16	31-5/16	88-3/16	12	15	607	626
	G7-45E-84-60DT	G8-45E-84-60DT	84	93	12-1/2	13	29-1/2	73-5/8	72-7/8	5/8	33-3/4	34-1/8	99-13/16	12	15	682	704
	G7-45E-96-60DT	G8-45E-96-60DT	96	105	12-1/2	13	33-1/2	83-3/16	82-1/2	5/8	36-5/8	36-15/16	111-3/16	12	15	756	780
	G7-45E-108-60DT	G8-45E-108-60DT	108	117	12-1/2	13	37-1/2	92-15/16	92-3/16	5/8	39-7/16	39-3/4	122-11/16	12	15	829	856
	G7-45E-120-60DT	G8-45E-120-60DT	120	129	12-1/2	13	41-1/2	102-9/16	101-7/8	5/8	42-1/4	42-5/8	134-1/4	12	15	903	933

# 60DT IDLERS

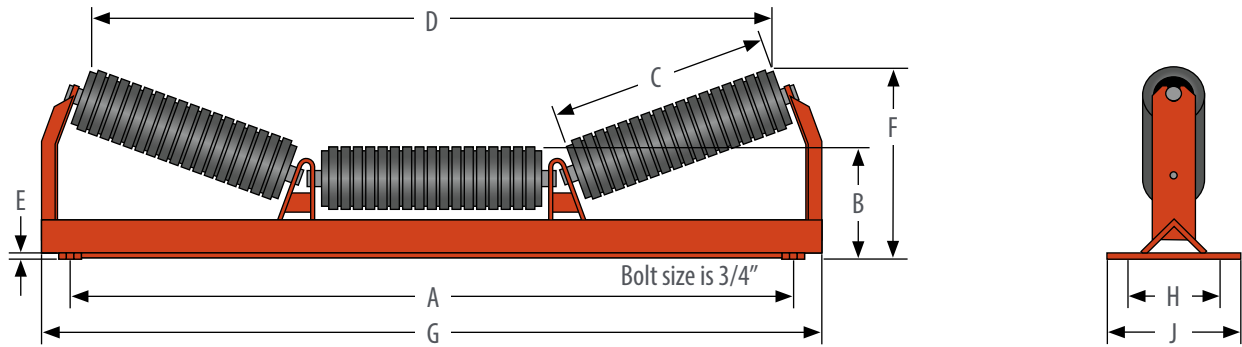

## RUBBER CUSHION IMPACT TROUGHING IDLER: 8" DIAMETER

	PART NUMBER	BW	A	B	C	D	E	F	G	H	J	WT (#)
20°	G8-20EI-60-60DT	60	69	13	21-1/2	65-1/4	5/8	20-5/8	76-9/16	12	15	509
	G8-20EI-72-60DT	72	81	13	25-1/2	76-13/16	5/8	22	88-3/16	12	15	579
	G8-20EI-84-60DT	84	93	13	29-1/2	88-5/16	5/8	23-3/8	99-13/16	12	15	649
	G8-20EI-96-60DT	96	105	13	33-1/2	99-13/16	5/8	24-3/4	111-3/16	12	15	720
	G8-20EI-108-60DT	108	117	13	37-1/2	111-3/8	5/8	26-1/8	122-11/16	12	15	790
	G8-20EI-120-60DT	120	129	13	41-1/2	122-7/8	5/8	27-1/2	134-1/4	12	15	861
35°	G8-35EI-60-60DT	60	69	13	21-1/2	58-7/16	5/8	25-9/16	76-9/16	12	15	522
	G8-35EI-72-60DT	72	81	13	25-1/2	69	5/8	27-7/8	88-3/16	12	15	593
	G8-35EI-84-60DT	84	93	13	29-1/2	79-9/16	5/8	30-3/16	99-13/16	12	15	665
	G8-35EI-96-60DT	96	105	13	33-1/2	90-1/16	5/8	32-1/2	111-3/16	12	15	737
	G8-35EI-108-60DT	108	117	13	37-1/2	100-11/16	5/8	34-3/4	122-11/16	12	15	809
	G8-35EI-120-60DT	120	129	13	41-1/2	111-1/4	5/8	37-1/16	134-1/4	12	15	881
45°	G8-45EI-60-60DT	60	69	13	21-1/2	53-9/16	5/8	28-7/16	76-9/16	12	15	534
	G8-45EI-72-60DT	72	81	13	25-1/2	63-1/4	5/8	31-5/16	88-3/16	12	15	606
	G8-45EI-84-60DT	84	93	13	29-1/2	72-7/8	5/8	34-1/8	99-13/16	12	15	680
	G8-45EI-96-60DT	96	105	13	33-1/2	82-1/2	5/8	36-15/16	111-3/16	12	15	754
	G8-45EI-108-60DT	108	117	13	37-1/2	92-3/16	5/8	39-3/4	122-11/16	12	15	826
	G8-45EI-120-60DT	120	129	13	41-1/2	101-7/8	5/8	42-5/8	134-1/4	12	15	900

# 60DT IDLERS

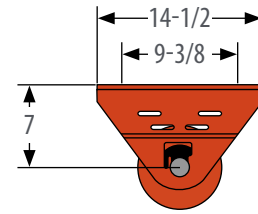
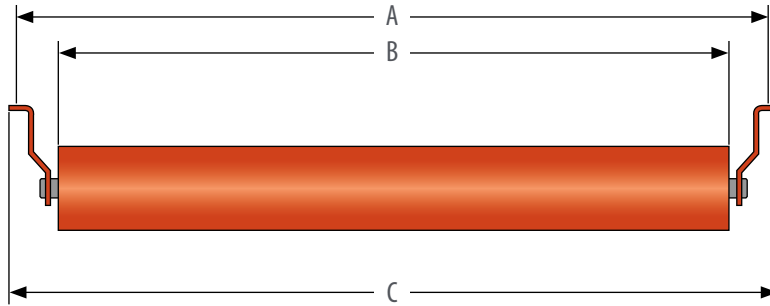

SLOTTED FOR 3/4" Ø BOLT

## RETURN IDLERS: 7" AND 8" DIAMETER

PART NUMBER		BW	A	B	C	WT (#)	
7"	8"					7"	8"
G7-RET-60-60DT	G8-RET-60-60DT	60	69	63	71	323	372
G7-RET-72-60DT	G8-RET-72-60DT	72	81	75	83	377	432
G7-RET-84-60DT	G8-RET-84-60DT	84	93	87	95	431	492
G7-RET-96-60DT	G8-RET-96-60DT	96	105	99	107	485	552
G7-RET-108-60DT	G8-RET-108-60DT	108	117	111	119	539	612
G7-RET-120-60DT	G8-RET-120-60DT	120	129	123	131	593	672

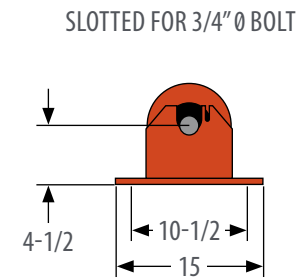
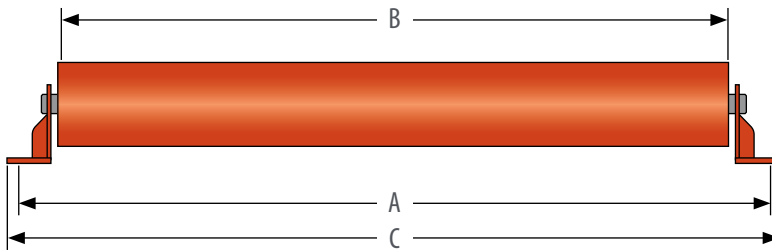

SLOTTED FOR 3/4" Ø BOLT

## FLAT IDLERS: 7" AND 8" DIAMETER

PART NUMBER		BW	A	B	C	WT (#)	
7"	8"					7"	8"
G7-FLT-60-60DT	G8-FLT-60-60DT	60	69	63	71	323	372
G7-FLT-72-60DT	G8-FLT-72-60DT	72	81	75	83	377	432
G7-FLT-84-60DT	G8-FLT-84-60DT	84	93	87	95	431	492
G7-FLT-96-60DT	G8-FLT-96-60DT	96	105	99	107	485	552
G7-FLT-108-60DT	G8-FLT-108-60DT	108	117	111	119	539	612
G7-FLT-120-60DT	G8-FLT-120-60DT	120	129	123	131	593	672



# 60DT IDLERS

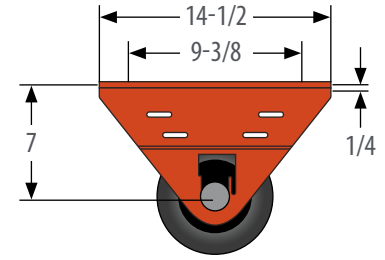
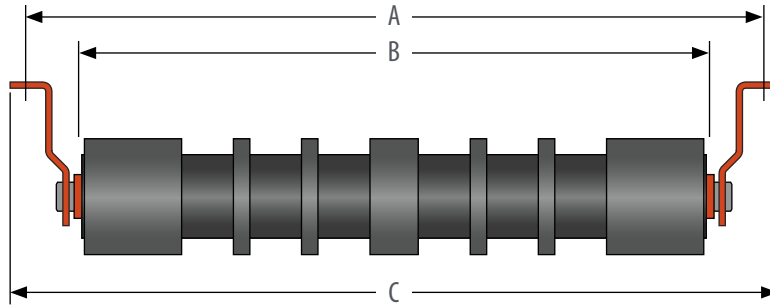

SLOTTED FOR 3/4" Ø BOLT

## RUBBER CUSHION RETURN IDLERS: 8" DIAMETER

PART NUMBER	BW	A	B	C	WT (#)
G8-RETI-60-60DT	60	69	63	71	355
G8-RETI-72-60DT	72	81	75	83	415
G8-RETI-84-60DT	84	93	87	95	475
G8-RETI-96-60DT	96	105	99	107	535
G8-RETI-108-60DT	108	117	111	119	595
G8-RETI-120-60DT	120	129	123	131	655

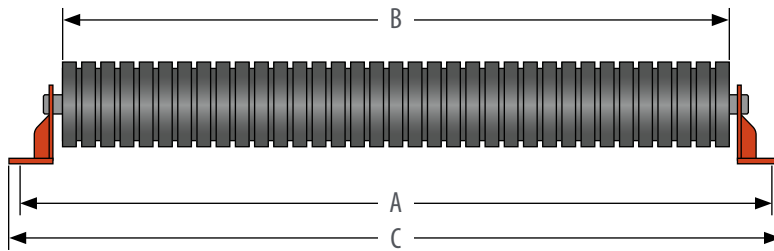

SLOTTED FOR 3/4" Ø BOLT

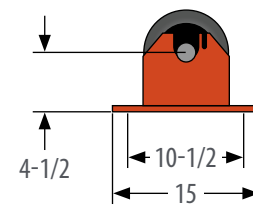

## RUBBER CUSHION FLAT IDLERS: 8" DIAMETER

PART NUMBER	BW	A	B	C	WT (#)
G8-FLTI-60-60DT	60	69	63	71	355
G8-FLTI-72-60DT	72	81	75	83	415
G8-FLTI-84-60DT	84	93	87	95	475
G8-FLTI-96-60DT	96	105	99	107	535
G8-FLTI-108-60DT	108	117	111	119	595
G8-FLTI-120-60DT	120	129	123	131	655

# 60DT IDLERS

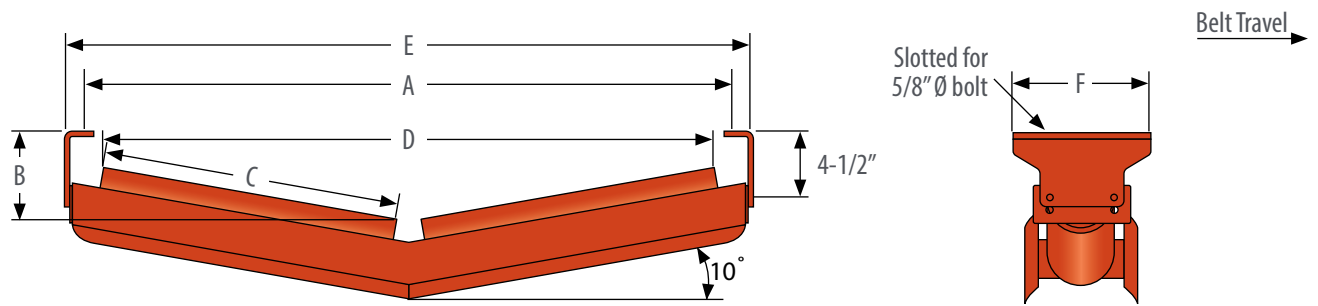

For wider base use next size larger belt width. Also available in 15°.

## V-RETURN IDLERS: 7 & 8 INCH DIAMETER

PART NUMBER		BW	A	B		C	D		E	F	G	WT (#)	
7"	8"			7"	8"		7"	8"				7"	8"
G7-10RETV-60-60DT	G8-10RETV-60-60DT	60	69	9-3/16	8-11/16	31-1/2	64-1/2	64-5/16	72-1/2	17-11/16	14-1/2	462	528
G7-10RETV-72-60DT	G8-10RETV-72-60DT	72	81	10-1/4	9-3/4	37-1/2	76-1/2	76-5/16	84-1/2	18-3/4	14-1/2	1194	1340
G7-10RETV-84-60DT	G8-10RETV-84-60DT	84	93	11-1/4	10-13/16	43-1/2	88-1/2	88-5/16	96-1/2	19-13/16	14-1/2	603	681
G7-10RETV-96-60DT	G8-10RETV-96-60DT	96	105	12-3/8	11-15/16	50	100-1/2	100-5/16	108-1/2	20-7/8	14-1/2	678	763
G7-10RETV-108-60DT	G8-10RETV-108-60DT	108	117	13-3/8	12-7/8	55-1/2	112-1/2	112-5/16	120-1/2	21-15/16	14-1/2	744	835
G7-10RETV-120-60DT	G8-10RETV-120-60DT	120	129	14-3/8	13-15/16	61-1/2	124-1/2	124-5/16	132-1/2	23	14-1/2	815	911

# COMPONENT PARTS AND REPLACEMENT ROLLS

## CEMA B REPLACEMENT ROLLS

CEMA B REPLACEMENT IDLER ROLLS					
BW	Assembled Roll Approx. Length	4" Dia. Roll Part Number	WT (#)	5" Dia. Roll Part Number	WT (#)
14 & 16	6-1/16	B4-14	4	B5-14	6
18	7-1/16	B4-18	5	B5-18	7
20	7-11/16	B4-20	5	B5-20	7
24	9-1/16	B4-24	6	B5-24	8
30	11-1/16	B4-30	7	B5-30	10
36	13-1/16	B4-36	8	B5-36	11
42	15-1/16	B4-42	9	B5-42	13
48	17-1/16	B4-48	10	B5-48	14
18	7-1/16	B4-EI-18	6	B5-EI-18	7
20	7-11/16	B4-EI-20	7	B5-EI-20	8
24	9-1/16	B4-EI-24	8	B5-EI-24	9
30	11-1/16	B4-EI-30	9	B5-EI-30	11
36	13-1/16	B4-EI-36	11	B5-EI-36	13
42	15-1/16	B4-EI-42	12	B5-EI-42	15
48	17-1/16	B4-EI-48	14	B5-EI-48	17

Equal Length Idler Rolls

Rubber Impact Idler Rolls

## CEMA C REPLACEMENT ROLLS

CEMA C REPLACEMENT IDLER ROLLS							
BW	Assem. Roll Approx. Length	4" Dia. Roll Part Number	WT (#)	5" Dia. Roll Part Number	WT (#)	6" Dia. Roll Part Number	WT (#)
18	7-1/16	C4-18	6	C5-18	8	C6-18	10
24	9-1/16	C4-24	7	C5-24	9	C6-24	13
30	11-1/16	C4-30	8	C5-30	11	C6-30	15
36	13-1/16	C4-36	9	C5-36	12	C6-36	17
42	15-1/16	C4-42	10	C5-42	14	C6-42	19
48	17-1/16	C4-48	11	C5-48	15	C6-48	21
54	19-1/16	C4-54	12	C5-54	17	C6-54	24
60	21-1/16	C4-60	13	C5-60	19	C6-60	26
18	7-1/16	C4-EI-18	7	C5-EI-18	8	C6-EI-18	10
24	9-1/16	C4-EI-24	8	C5-EI-24	10	C6-EI-24	13
30	11-1/16	C4-EI-30	10	C5-EI-30	12	C6-EI-30	15
36	13-1/16	C4-EI-36	12	C5-EI-36	14	C6-EI-36	18
42	15-1/16	C4-EI-42	13	C5-EI-42	16	C6-EI-42	21
48	17-1/16	C4-EI-48	15	C5-EI-48	18	C6-EI-48	23
54	19-1/16	C4-EI-54	17	C5-EI-54	20	C6-EI-54	26
60	21-1/16	C4-EI-60	18	C5-EI-60	23	C6-EI-60	29

Equal Length Idler Rolls

Rubber Impact Idler Rolls

# COMPONENT PARTS AND REPLACEMENT ROLLS

## CEMA D REPLACEMENT ROLLS

CEMA D REPLACEMENT IDLER ROLLS					
BW	Length*	5" Dia. Roll Part Number	WT (#)	6" Dia. Roll Part Number	WT (#)
18	7-1/16	D5-18	10	D6-18	12
24	9-1/16	D5-24	11	D6-24	15
30	11-1/16	D5-30	13	D6-30	17
36	13-1/16	D5-36	15	D6-36	20
42	15-1/16	D5-42	16	D6-42	22
48	17-1/16	D5-48	18	D6-48	24
54	19-1/16	D5-54	20	D6-54	27
60	21-1/16	D5-60	22	D6-60	29
72	25-1/16	D5-72	25	D6-72	34
<b>Equal Length Idler Rolls</b>					
18	7-1/16	D5-EI-18	11	D6-EI-18	13
24	9-1/16	D5-EI-24	14	D6-EI-24	16
30	11-1/16	D5-EI-30	16	D6-EI-30	19
36	13-1/16	D5-EI-36	19	D6-EI-36	22
42	15-1/16	D5-EI-42	22	D6-EI-42	26
48	17-1/16	D5-EI-48	26	D6-EI-48	29
54	19-1/16	D5-EI-54	27	D6-EI-54	32
60	21-1/16	D5-EI-60	30	D6-EI-60	36
72	25-1/16	D5-EI-72	36	D6-EI-72	42

## CEMA E REPLACEMENT ROLLS

CEMA E REPLACEMENT IDLER ROLLS					
BW	Length*	6" Dia. Roll Part Number	WT (#)	7" Dia. Roll Part Number	WT (#)
36	12-3/4	E6-36	32	E7-36	36
42	14-3/4	E6-42	36	E7-42	40
48	17-1/2	E6-48	41	E7-48	46
54	19-1/2	E6-54	45	E7-54	51
60	21-1/2	E6-60	49	E7-60	55
72	25-1/2	E6-72	57	E7-72	64
84	29-1/2	E6-84	65	E7-84	72
96	33-1/2	E6-96	73	E7-96	81
<b>Equal Length Idler Rolls</b>					
36	12-3/4	E6-EI-36	29	E7-EI-36	29
42	14-3/4	E6-EI-42	33	E7-EI-42	33
48	17-1/2	E6-EI-48	39	E7-EI-48	39
54	19-1/2	E6-EI-54	43	E7-EI-54	43
60	21-1/2	E6-EI-60	47	E7-EI-60	47
72	25-1/2	E6-EI-72	54	E7-EI-72	54
84	29-1/2	E6-EI-84	62	E7-EI-84	62
96	33-1/2	E6-EI-96	70	E7-EI-96	70

## OTHER PARTS

PART NUMBER	DESCRIPTION	PART NUMBER	DESCRIPTION
13-01412	Hex Nut Adapter - Superior	13-10071	CEMA C 35° Center Stand Clip
09-104200	CEMA B Rubber Disc 4" Dia. x 2" I.D.	13-10072	CEMA C 45° Center Stand Clip
09-105200	CEMA B Rubber Disc 5" Dia. x 2" I.D.	13-10073	CEMA D 20° Center Stand Clip
09-104225	CEMA C Rubber Disc 4" Dia. x 2 1/4" I.D.	13-10074	CEMA D 35° Center Stand Clip
09-105225	CEMA C Rubber Disc 5" Dia. x 2 1/4" I.D.	13-10075	CEMA D 45° Center Stand Clip
09-106225	CEMA C Rubber Disc 6" Dia. x 2 1/4" I.D.	13-10068	CEMA B & C End Stand Clip
09-105300	CEMA D Rubber Disc 5" Dia. x 3" I.D.	13-10069	CEMA D End Stand Clip
09-106300	CEMA D Rubber Disc 6" Dia. x 3" I.D.	03-02501	CEMA B Bearing and Seal Kit
09-106400	CEMA E Rubber Disc 6" Dia. x 4" I.D.	03-02502	CEMA C Bearing and Seal Kit
09-107400	CEMA E Rubber Disc 7" Dia. x 4" I.D.	03-02503	CEMA D Bearing and Seal Kit
13-10070	CEMA C 20° Center Stand Clip	03-02499	CEMA E Bearing and Seal Kit



Hex Nut Adaptor

\*Assembled roll approximate length

# 40 SERIES IDLERS

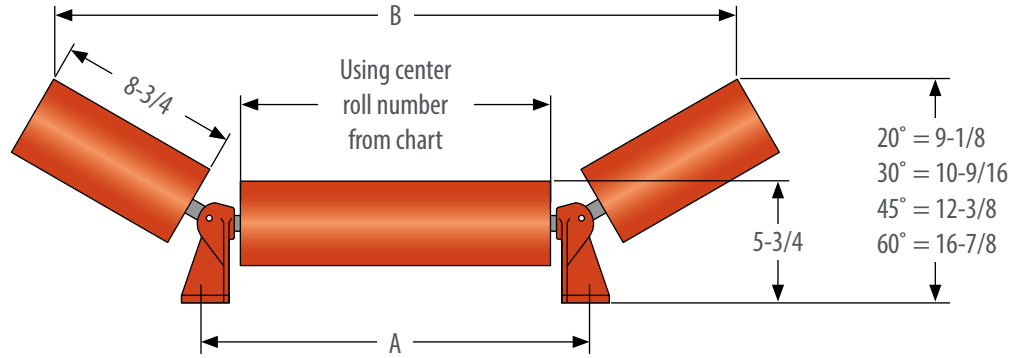

## 40 SERIES IDLER

CENTER ROLL PART #	POWER-SCREEN NUMBER	RCMD. BW	A	B				CENTER ROLL LENGTH	SHAFT LENGTH
				20°	30°	45°	60°T		
43-000010	07020238	24	11-7/8	27-15/16	25-13/16	21-3/4	13-9/16	8.14	9.20
43-000011	02021138	30	15-3/4	31-13/16	29-11/16	25-5/8	17-7/16	12.00	13.06
43-000012	08010101	30	18-5/8	34-11/16	32-9/16	28-1/2	20-5/16	14.87	15.93
43-000013	06530102	36	22-5/8	38-11/16	36-9/16	32-1/2	24-5/16	18.87	19.93
43-000014	05120115	36	24-9/16	40-5/8	38-1/2	34-7/16	26-1/4	20.87	21.87
43-000015	04220133	42	28-7/8	44-15/16	42-13/16	38-3/4	30-9/16	25.15	26.21
43-000016	09130180	42	30-1/2	46-9/16	44-7/16	40-3/8	32-3/16	26.75	27.81
43-000017	09120129	48	38-13/16	54-7/8	52-3/4	48-11/16	40-1/2	35.07	36.13
43-000018	03220103	54	39-9/16	55-5/8	53-1/2	49-7/16	41-1/4	33.87	36.87

## CENTER BRACKETS

PART NUMBER	POWER-SCREEN #	DESCRIPTION	DEGREE
43-000021	LH2020608 RH2020609	Center bracket only	20
43-000022	LH2020606 RH2020607	Center bracket only	30
43-000023	LH2020604 RH2020605	Center bracket only	45
43-000024	LH2020610 RH2020611	Center bracket only	60

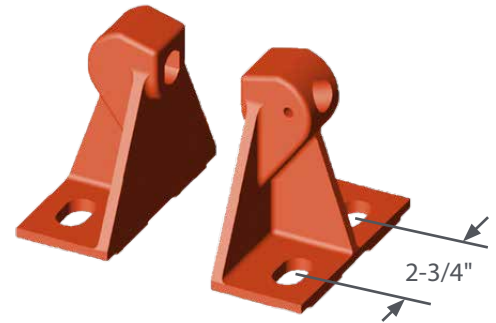

## OUTSIDE ROLLS

PART NUMBER	POWER-SCREEN #	DESCRIPTION	DEGREE	ROLL LENGTH
43-000019	8-3/4	Outside roller only	Fits all degrees	8-3/4

## RETURN ROLLS

PART NUMBER	POWER-SCREEN #	ROLL LENGTH	SHAFT LENGTH	METRIC SIZE	RCMD. BW
43-000025	02021145	28.00	33.00	L840	24
43-000026	06530103	33.50	38.50	L978	30
43-000027	05420143	33.62	38.62	L980	30
43-000028	08010102	35.50	40.50	L1025	30
43-000029	05120116	40.00	45.00	L1145	36
43-000030	03220104	53.50	58.50	L1485	48
43-000031	07230107	62.00	67.00	L1700	60

## RETURN ROLL U-BOLTS

PART NUMBER	SHAFT DIAMETER
13-03004	1
13-03005	0.75

Add "TTM", "DRY", "WET", "LOW" to the end of the part number to add application specific seals.

# LIVE SHAFT IDLERS

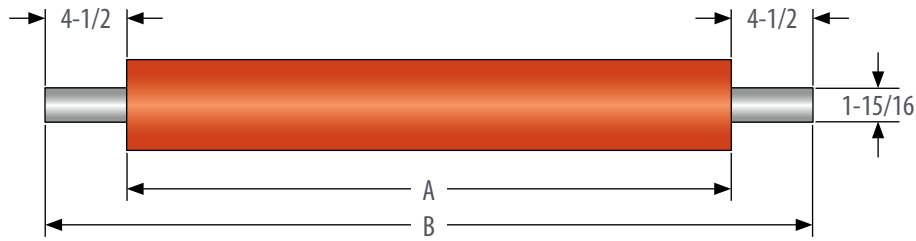

## LIVE SHAFT ROLLER: 4", 5" AND 6" DIAMETER (STEEL AND IMPACT)

PART NUMBER						BW	A	B
4" DIAMETER	WT (#)	5" DIAMETER	WT (#)	6" DIAMETER	WT (#)			
LS-418	41	LS-518	47	LS-618	54	18	21-5/16	30-5/16
LS-420	44	LS-520	51	LS-620	58	20	23-5/16	32-5/16
LS-424	51	LS-524	58	LS-624	66	24	27-5/16	36-5/16
LS-430	60	LS-530	68	LS-630	79	30	33-5/16	42-5/16
LS-436	69	LS-536	79	LS-636	91	36	39-5/16	48-5/16
LS-442	78	LS-542	89	LS-642	103	42	45-5/16	54-5/16
LS-448	87	LS-548	100	LS-648	115	48	51-5/16	60-5/16
LS-454	97	LS-554	111	LS-654	128	54	57-5/16	66-5/16
LS-460	106	LS-560	121	LS-660	140	60	63-5/16	72-5/16

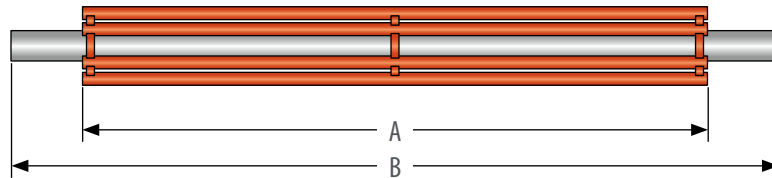

## BEATER BAR RETURN ROLL: 1-7/16" AND 1-15/16" SHAFT SIZE

ROLL DIAMETER		BW	A	B	WT		ROLL DIAMETER		BW	A	B	WT (#)	
5"	6"				5"	6"	5"	6"				5"	6"
LSB-518-107	LSB-618-107	18	21-5/16	30-5/16	36	38	LSB-518-115	LSB-618-115	18	21-5/16	30-5/16	47	49
LSB-524-107	LSB-624-107	24	27-5/16	36-5/16	44	46	LSB-524-115	LSB-624-115	24	27-5/16	36-5/16	57	59
LSB-530-107	LSB-630-107	30	33-5/16	42-5/16	53	56	LSB-530-115	LSB-630-115	30	33-5/16	42-5/16	69	71
LSB-536-107	LSB-636-107	36	39-1/16	48-5/16	61	64	LSB-536-115	LSB-636-115	36	39-1/16	48-5/16	79	82
LSB-542-107	LSB-642-107	42	45-5/16	54-5/16	69	72	LSB-542-115	LSB-642-115	42	45-5/16	54-5/16	89	92
LSB-548-107	LSB-648-107	48	51-5/16	60-5/16	79	83	LSB-548-115	LSB-648-115	48	51-5/16	60-5/16	100	104
LSB-554-107	LSB-654-107	54	57-5/16	66-5/16	87	91	LSB-554-115	LSB-654-115	54	57-5/16	66-5/16	111	115
LSB-560-107	LSB-660-107	60	63-5/16	72-5/16	95	99	LSB-560-115	LSB-660-115	60	63-5/16	72-5/16	121	125
LSB-572-107	LSB-672-107	72	75-5/16	84-5/16	112	117	LSB-572-115	LSB-672-115	72	75-5/16	84-5/16	143	148

Note: Impact designated by (LSI-)  
Bearings not included but available (03-00115 SCM 1-15/16 bearing and 03-00115 1-7/16" bearing)

Note: Part number for live shaft bearing 107: 03-00110  
Note: Part number for live shaft bearing 115: 03-00115

# SPECIALIZED IDLER DESIGNS



## SUPERIOR INGENUITY

Examples of custom conveyor components:

- » Modified bolt centers
- » Neoprene & rubber coating
- » Special roller lengths
- » Various shaft styles
- » Special dimensions
- » Wire rope idlers
- » Custom return rolls to fit existing brackets
- » Special guide idlers
- » Scale quality idlers
- » Lagged Return Rollers



## POWDER COATED PROTECTION

To ensure the best quality on all of our conveyor components, all of our idlers are powder coated.



## FASTEST LEAD TIMES

- » Quickest deliveries in the industry.
- » In need of standard or specially designed idlers and pulleys? Superior can eliminate the hassles of finding the right component for any application.

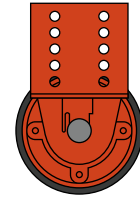
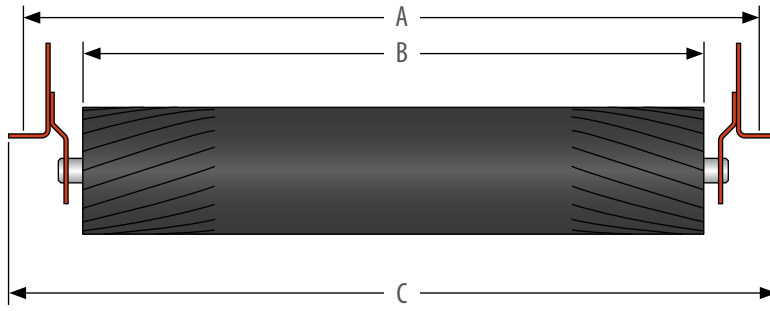

Lagged 1.5" Drop

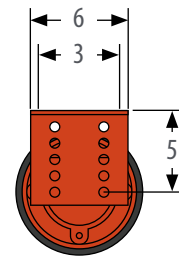
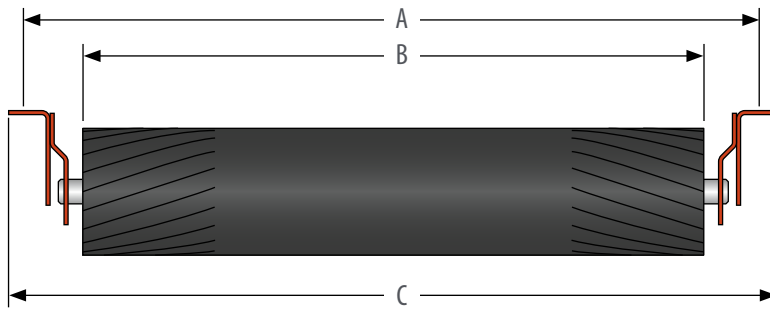

Lagged 4.5 Drop

**NAVIGATOR RETURN TRAINER: 7-3/4" AND 7", 10" AND 10-3/4" DIAMETER**

PART NUMBER		BW	A	B	C	DIAMETER		WT (#)		STANDARD DROP BRACKET	BIDIRECTIONAL DROP BRACKET
LAGGED	NOT LAGGED					LAGGED	NOT LAGGED	LAGGED	NOT LAGGED		
NAV-24LAG	NAV-24	24	33	26	35	7-3/4	7	87	76	32-010009	32-010050
NAV-30LAG	NAV-30	30	39	32	41	7-3/4	7	101	88	32-010009	32-010050
NAV-36LAG	NAV-36	36	45	38	47	7-3/4	7	116	100	32-010009	32-010050
NAV-42LAG	NAV-42	42	51	44	53	10-3/4	10	180	153	32-010019	32-010052
NAV-48LAG	NAV-48	48	57	50	59	10-3/4	10	201	171	32-010019	32-010052
NAV-54LAG	NAV-54	54	63	56	65	10-3/4	10	244	210	32-010020	32-010054
NAV-60LAG	NAV-60	60	69	62	71	10-3/4	10	267	230	32-010020	32-010054
NAV-66LAG	NAV-66	66	75	68	77	10-3/4	10	291	250	32-010020	32-010054
NAV-72LAG	NAV-72	72	81	74	83	10-3/4	10	314	269	32-010020	32-010054



**RETURN GUIDES**

Part Number: 42-000001

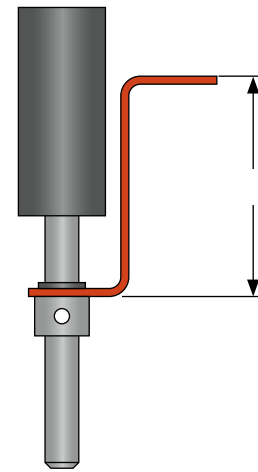
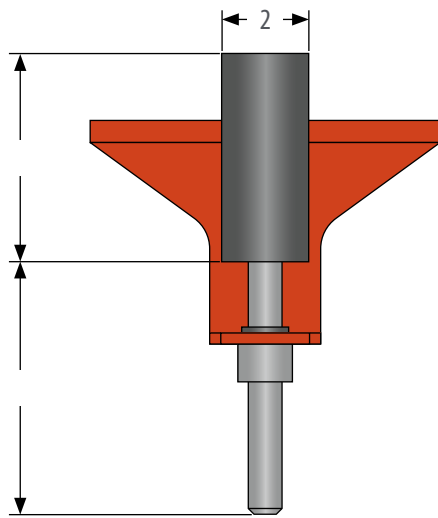
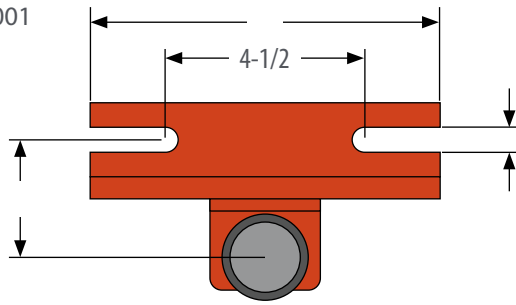

**PIPE CONVEYOR ROLLER BRACKET ASSEMBLY**

Part Number: 26-500000

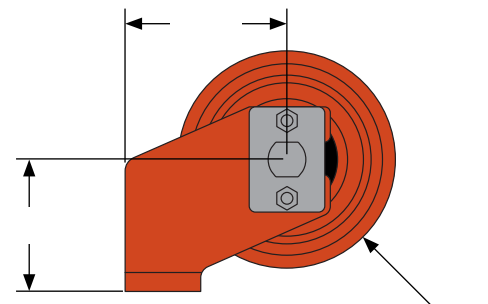
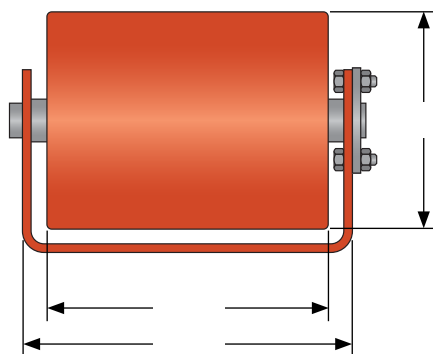
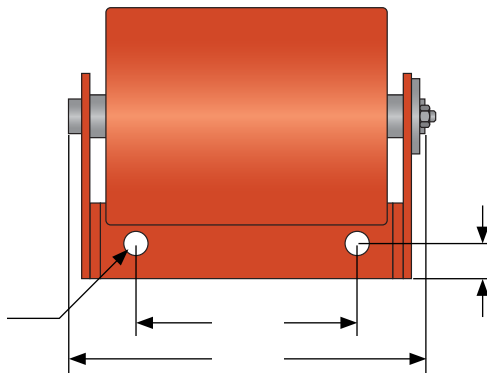

---

# COMPONENTS ACCESSORIES

## RETURN GUIDE & DROP BRACKET

Part Number: 42-000040

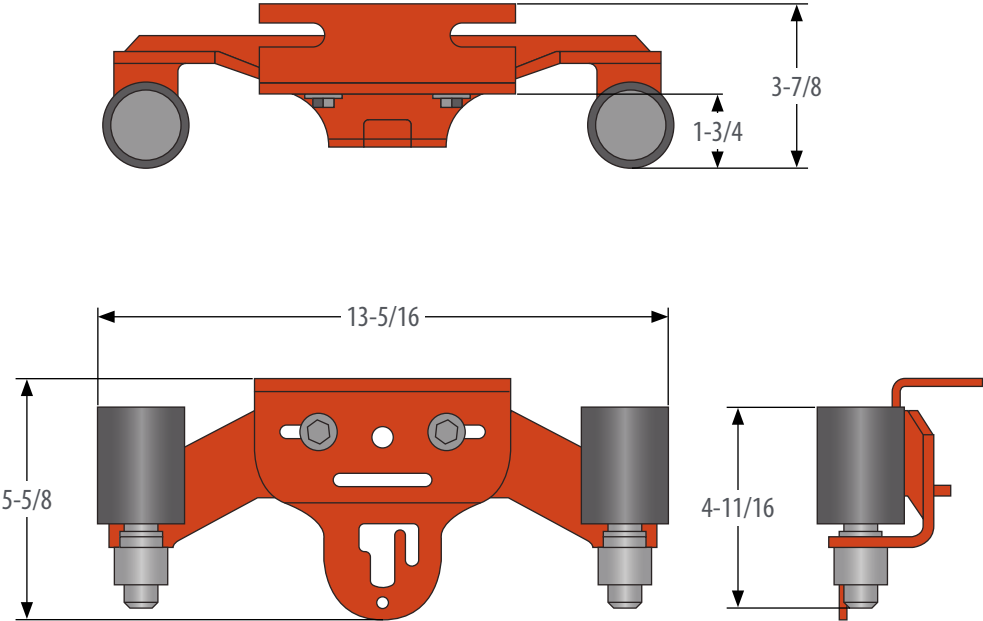

# COMPONENT ACCESSORIES

## SIDE GUIDE IDLERS: 4" X 5-3/8" ROLLERS

	PART NUMBER	BW	A	B	C	D	E	F
20°	42-200020	14-20	9-3/16	7-3/16	11/16	3	6-13/16	8-5/16
	42-200036	24-36	11-3/16	8-15/16	3/4	3-1/8	8-9/16	10-5/16
	42-200048	42-48	13-7/16	11-3/16	3/4	3-1/8	10-13/16	12-9/16
	42-200060	54-60	15-3/16	12-3/4	7/8	3-3/16	12-3/8	14-5/16
35°	42-350030	14-24	12-11/16	10-5/8	1-5/16	3-5/16	10	11-1/4
	42-350036	30-36	15-1/4	12-3/8	1-7/8	3-15/16	11-3/4	13-13/16
	42-350048	42-48	17-15/16	14-1/8	2-9/16	4-9/16	13-1/2	16-1/2
	42-350060	54-60	20-11/16	16	3-1/8	5-3/16	15-3/8	19-1/4

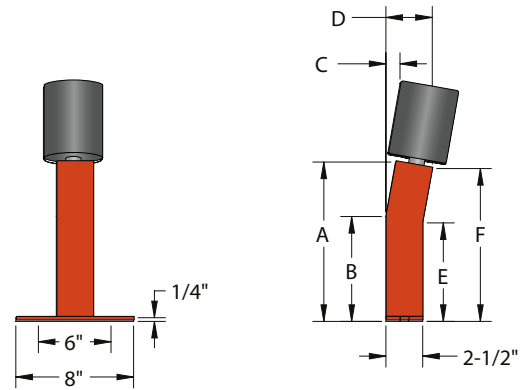

## STUB ROLL IDLERS: 4", 5" AND 6" DIAMETER

PART NUMBER	A	B	C	SHAFT	THREAD
*42-404458	4	4	4	17 MM	5/8-18
*42-504458	5	4	4	17 MM	5/8-18
*42-404558	4	4-1/2	4-1/2	17 MM	5/8-18
*42-504558	5	4-1/2	4-1/2	17 MM	5/8-18
*42-404475	4	4	4	3/4	3/4-16
*42-505575	5	5	5	3/4	3/4-16
*42-605575	6	5	5	3/4	3/4-16
*42-405675	4	5	6	3/4	3/4-16
*42-505675	5	5	6	3/4	3/4-16
*42-606675	6	6	6	3/4	3/4-16

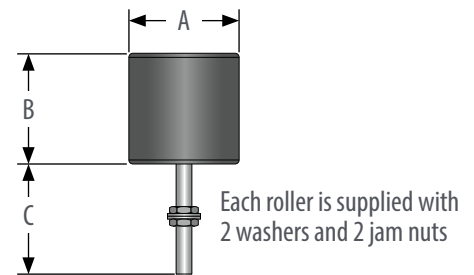

## VERTICAL SIDE GUIDE ROLL: 2" AND 4" DIAMETER

	PART NUMBER	A	B	WT (#)
2"	42-020275	2-3/4	9-1/4	2
	*46-200004	2-3/4	6-3/4	2
	42-020475	4-3/4	10-1/2	3
	*46-001247	4-3/4	7-3/4	3
4"	42-604538	5-3/8	7-1/8	5

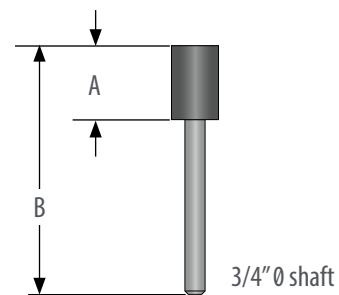

## URETHANE VERTICAL SIDE GUIDE ROLL: 3-1/4" DIAMETER

PART NUMBER	A	B	WT (#)
42-325275	2-3/4	9-1/4	5
*42-327275	2-3/4	6-3/4	5
42-325475	4-3/4	10-1/2	8
*42-327475	4-3/4	7-3/4	8

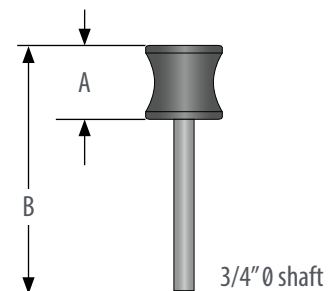

# RETURN & FLAT BRACKETS STYLES

## CEMA B, C, AND D BRACKETS

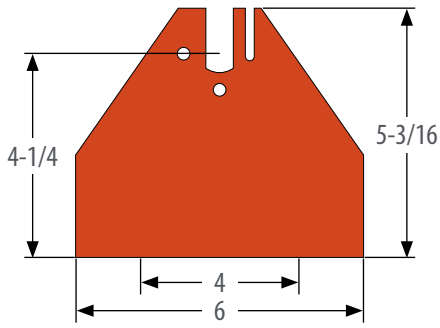

32-000019 4-1/4" Rise Bracket (2.94 lbs)\*

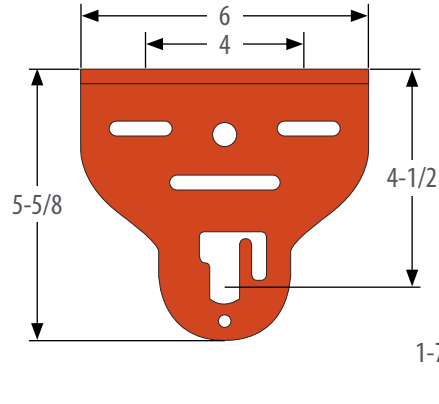
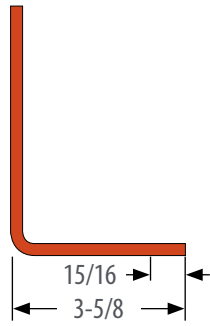

32-000017 4-1/2" Drop Bracket (1.63 lbs)\*

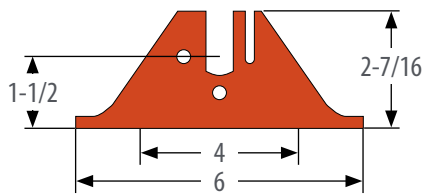
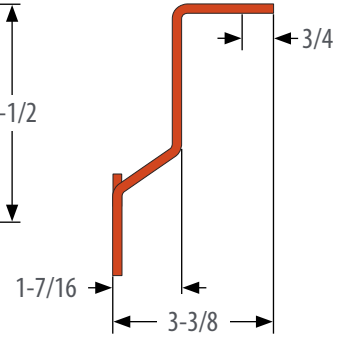

32-000020 1-1/2" Rise Bracket (1.78 lbs)\*

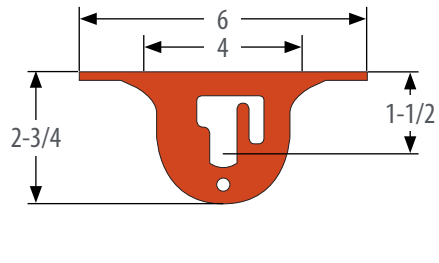
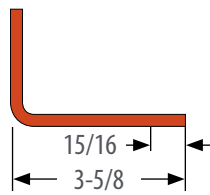

32-000018 1-1/2" Drop Bracket (0.87 lbs)\*

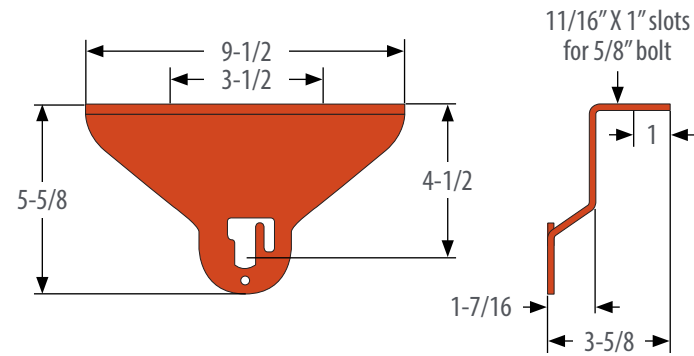
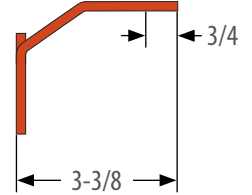

32-000021 4-1/2" (2.32 lbs)\*  
32-000022 1-1/2" (2.00 lbs)\*  
Universal Return Roll Bracket

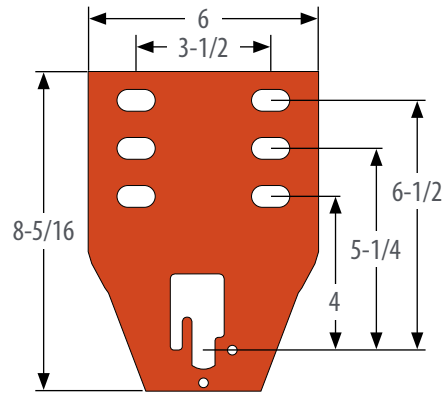
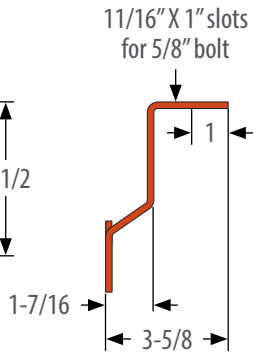

32-000023 Channel Mount Bracket (2.28 lbs)\*

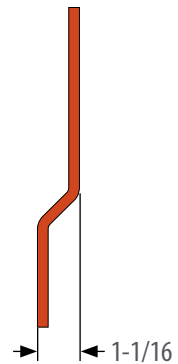

## CEMA E BRACKETS

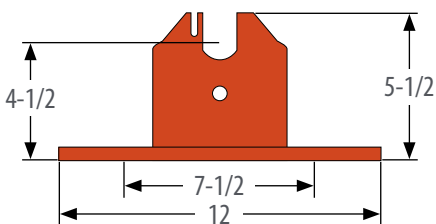

32-010040 1-1/2" Rise Bracket (5.31 lbs)  
32-010045 4-1/2" Rise Bracket (7.22 lbs)  
32-010036 6" Rise Bracket (8.50 lbs)

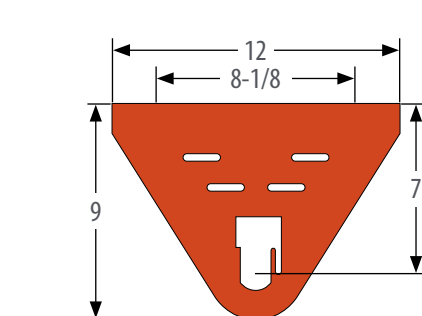
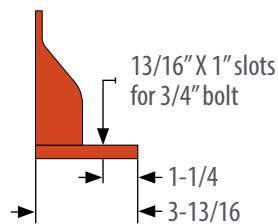

32-010075 CEMA E 7" Drop Bracket (6.52 lbs)

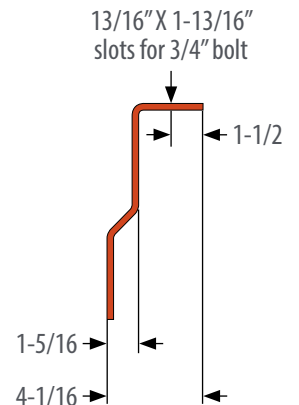

\* Part numbers use hold down kits. The hold down kit part numbers include 13-10076 (CEMA B and C) and 13-10077 (CEMA D).

9/16" x 1" slots for 1/2" bolt unless otherwise noted. Brackets are not shown to scale.

# RETURN & FLAT BRACKETS STYLES

## CEMA F RETURN BRACKETS

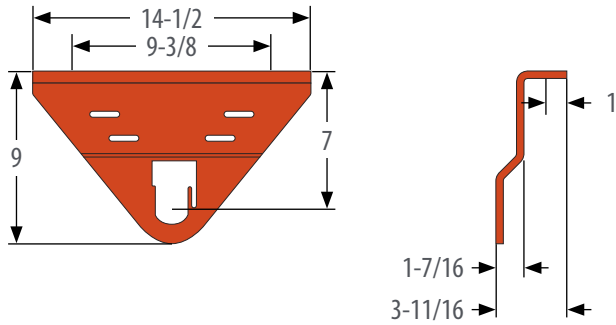

32-060000 CEMA F 7" Drop Bracket (10.56 lbs)

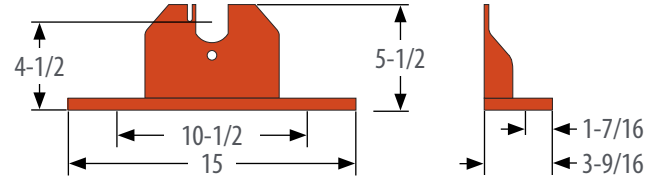

32-060002 CEMA F 4-1/2" Rise Bracket (10.00 lbs)

NOTE: 13/16" X 2-1/4" slots for 3/4" bolt. Brackets are not shown to scale.

## 81 & 91 SERIES RETURN BRACKETS - HEX

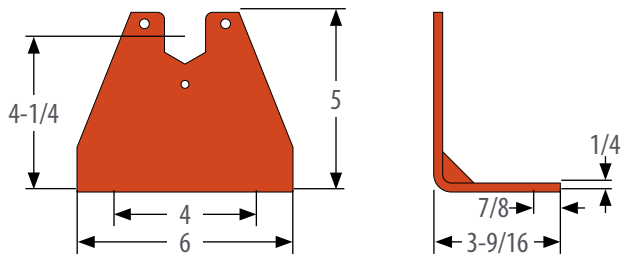

32-000412 4-1/4" Rise Hex Bracket (3.14 lbs)

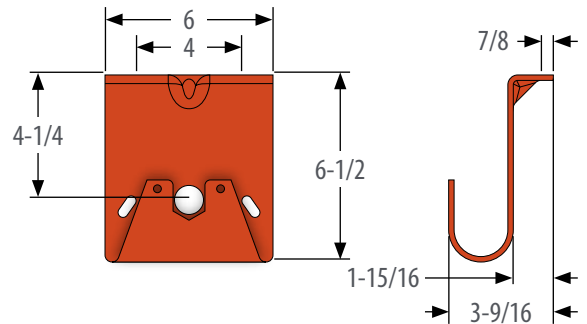

32-014046 4-1/2" Drop Hex Bracket (3.12 lbs)

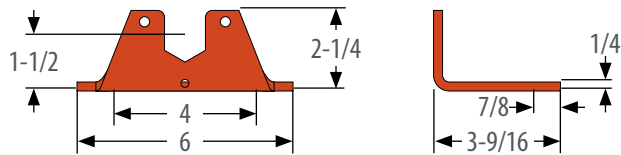

32-011608 1-1/2" Rise Hex Bracket (2.00 lbs)

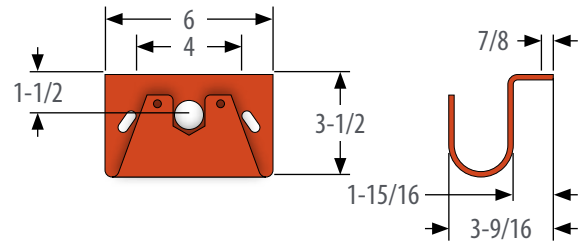

32-015120 1-1/2" Drop Hex Bracket (2.21 lbs)

9/16" x 1" slots for 1/2" bolt unless otherwise noted. Brackets are not shown to scale.

# RETURN & FLAT BRACKETS STYLES

## CB BRACKETS

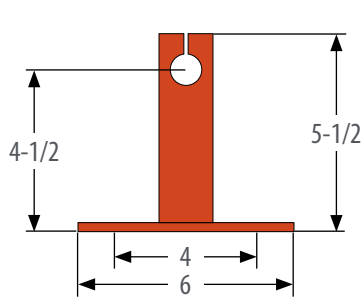

32-410450 4-1/2" CB Bracket (2.10 lbs)

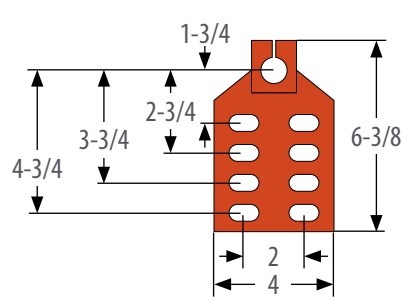
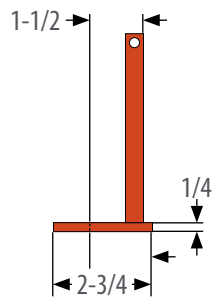

32-506000 CB Channel Mount Hex Bracket (2.00 lbs)

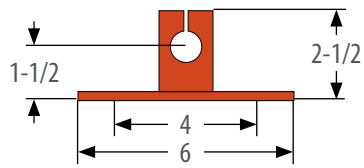
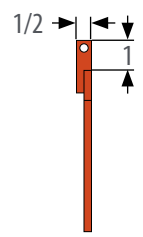

32-044081 1-1/2" CB Bracket (1.40 lbs)

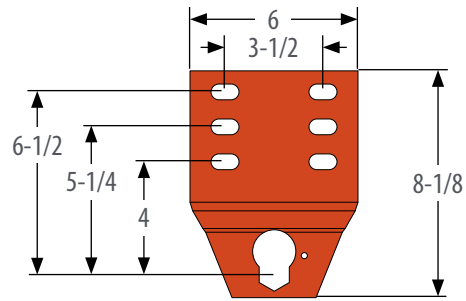
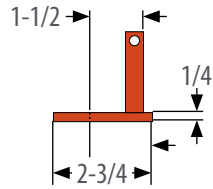

32-044080 CM Channel Mount Hex Bracket (2.00 lbs)

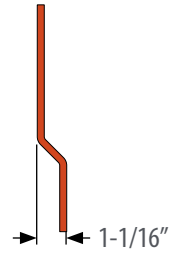

# BASE PLATES

## CEMA B, C AND D IDLERS

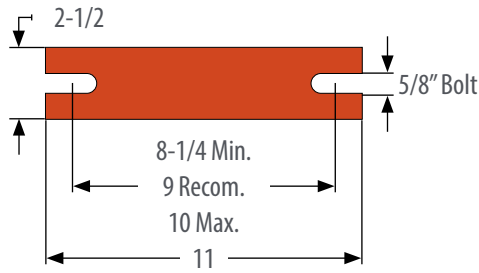

54"-72" Belt Width CEMA C & D (2.67 lbs)  
33-032511

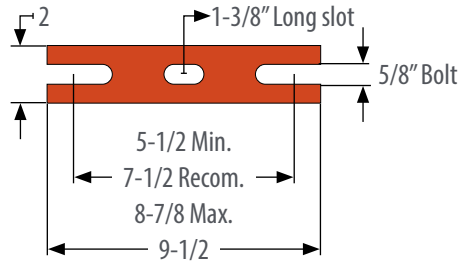

42"-48" BW CEMA B (1.34 lbs)  
24"-48" BW CEMA C & D  
33-000595

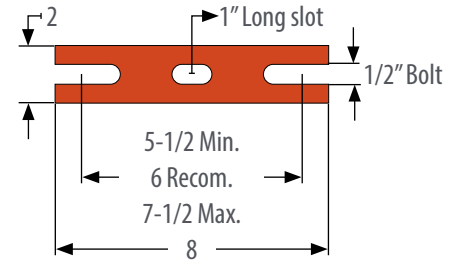

14"-36" BW CEMA B (0.97 lbs)  
14"-20" BW CEMA C  
33-018780

## CEMA E, F, AND DOUBLE TUBE IDLERS

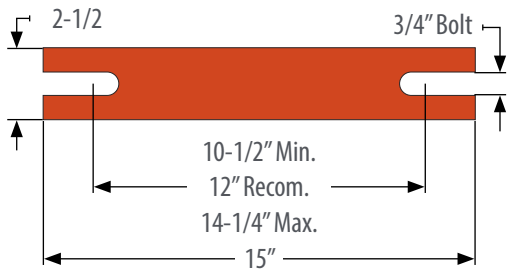

F, 50 DT, 60 DT  
33-001008

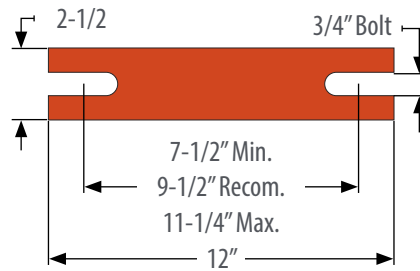

E, 40 DT, 45 DT  
36"-72" BW  
33-001001

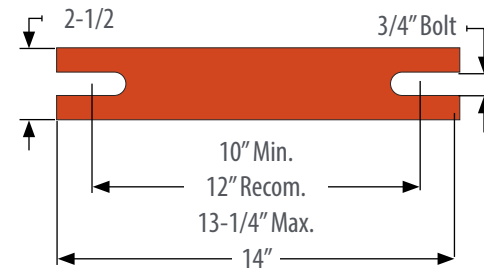

E, 40 DT, 45 DT  
78"-108" BW  
33-001002

# IDLER SELECTION PROCEDURE

## INITIAL SELECTION; STEPS 1, 2, AND 3:

Select idler class by comparing calculated idler load with idler load ratings (CIL and CILR) from Tables 2-11 through 2-14. Select impact idler class, if necessary, as shown in Step 3. CEMA idler manufacturers have standard designs meeting these load ratings and dimensional standards shown in tables listed in this publication.

## BEARING L10 LIFE CORRECTION; STEPS 4, 5, AND 6:

Factors K2 (Fig. 2.5) and K3A (Fig. 2.6) are multiplying factors used to adjust basic L10 life rating of idler class selected. Factor K2 is based on percent of idler load and K3A is factor of actual roll speed (RPM). Factor K3B (Fig. 2.7), step 5 is an optional step showing advantage of using larger diameter rolls. It can be used as a multiplier to save repeating step 5 if a larger diameter roll is used.

## DETERMINE POTENTIAL IDLER LIFE; STEP 7:

Factors K4A (Fig. 2.8), K4B (Fig. 2.9), and K4C (Fig. 2.10) show conditions which will affect idler life and are independent of bearing L10 life, idler load and idler class. Use these figures to evaluate the potential expected idler life.

## STEP NO.1 TROUGHING IDLERS SERIES SELECTION

Calculated Idler Load (lbs.) = CIL = ((WB + (WM x K1)) x SI) + IML

Where:

WB= Belt weight (lbs./ft.) use actual or estimate from Table 2-1

WM= Material weight (lbs./ft.) = (Q x 2000) / (60 x V)

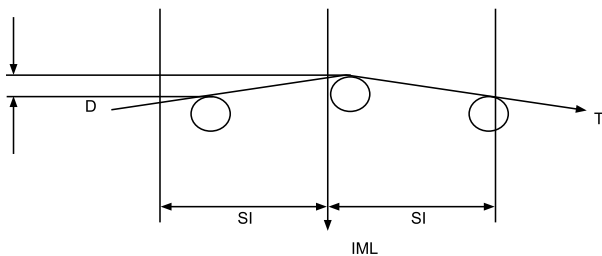

Q= Quantity of material conveyed (Tons per hour)

V= Design belt speed (FPM)

SI= Spacing of idlers (ft.)

K1= Lump adjustment factor (see Table 2-2)

Note: Actual weight of lump should be compared with WM value. In situations it may be necessary to use actual lump weight as WM.

IML= Idler misalignment load (lbs.) due to idler height deviation and belt tension = (D x T) / (6 x SI)

Where:

D= Misalignment (inches)

T= Belt Tension (lbs.)

SI= Idler Spacing (feet)

When an idler is higher than the adjacent idler, a component of belt tension will add load to that idler. The amount of height deviation can vary with the installation and type of idler. CEMA publication on "Conveyor Installation Standards" (Appendix D, "Belt Conveyors for Bulk Material," Fifth Edition or later) lists recommendations on structure misalignment.

Use CIL and select proper series of idler from Tables 2-11 through 2-14. CIL value should be equal to or less than idler rating.

This troughing idler selection procedure for calculating idler load does not include the following:

1. Impact force on idler at loading points.
2. Effect of belt transitions (head and tail pulley) on idler load.

**TABLE 2-1 WB ESTIMATED AVERAGE BELT WEIGHT FOR MULTIPLE AND REDUCED PLY BELTS PER UNIT LENGTH**

BELT WIDTH (INCHES)	MATERIAL CARRIED, LBS./CU. FT.		
	30-74	75-129	130-200
18	3.5	4	4.5
24	4.5	5.5	6
30	6	7	8
36	9	10	12
42	11	12	14
48	14	15	17
54	16	17	19
60	18	20	22
72	21	24	26
84	25	30	33
96	30	35	38

1. Steel cable belts increase above value by 50%.
2. Actual belt weights may vary with different constructions, manufacturers, cover gauges, etc. Use the above values for estimating. Obtain actual values from the belt manufacturer whenever possible.

**TABLE 2-2 K1 LUMP ADJUSTMENT FACTOR**

MATERIAL LUMP SIZE (INCHES)	MATERIAL WEIGHT, LBS./CU. FT.						
	50	75	100	125	150	175	200
4	1.0	1.0	1.0	1.0	1.1	1.1	1.1
6	1.0	1.0	1.0	1.1	1.1	1.1	1.1
8	1.0	1.0	1.1	1.1	1.2	1.2	1.2
10	1.0	1.1	1.1	1.1	1.2	1.2	1.2
12	1.0	1.1	1.1	1.2	1.2	1.2	1.3
14	1.1	1.1	1.1	1.2	1.2	1.3	1.3
16	1.1	1.1	1.2	1.2	1.3	1.3	1.3
18	1.1	1.1	1.2	1.2	1.3	1.3	1.4

## STEP NO. 2 RETURN IDLER SERIES SELECTION

Calculated Idler Load (lbs.) = CILR = (WB x SI) + IML

Use CILR and select proper series of idler from Tables 2-11 through 2-14. CILR should be equal to or less than return idler rating.

## STEP NO. 3 IMPACT IDLER SERIES SELECTION

For homogeneous material without lumps:

Impact Force (lbs.) = F = (0.1389)Q√H

Where:

Q= Rate of flow (ST/hr)

H= Height of fall (ft.)

The calculated impact force, (F) is then multiplied by an impact idler spacing factor, f (Table 2-3), to determine the impact force on one idler.

Unit Impact Force (lbs.) = Fu = F(f)

**TABLE 2-3 IMPACT IDLER SPACING FACTOR**

SI IMPACT	FACTOR f
1' 0"	0.5
1' 6"	0.7
2' 0"	0.9
>2' 0"	1



# IDLER SELECTION PROCEDURE

Use this unit impact force,  $F_u$ , and select proper series of impact idler from Tables 2-11 through 2-14.  $F_u$  should be equal to or less than idler rating.

For material containing large lumps:  
 Impact Force (lbs.) =  $F = W + (2kWH)^{1/2}$   
 Where:

W= Weight of lump (lbs.)

H= Height of fall (ft.)

k= Spring constant for specific idler type (lbs./ft.)

Use calculated energy rating, WH, and maximum lump size to select proper series of impact idler from Table 2-4. Both WH and lump size should be equal to or less than energy rating and maximum lump size.

Note: Both cases (material without lumps and material containing large lumps) should always be considered and the heavier duty idler selected to insure adequate impact resistance capabilities.

**TABLE 2-4 ENERGY RATINGS FOR IMPACT IDLERS**

3-ROLL RUBBER IMPACT IDLERS (EQUAL LENGTH ROLLS)		
CEMA Series	WH (lbs.-ft.)	Maximum Lump Size (in.)
B	40	4
C	160	6
D	240	8
E	460	12

## STEP NO. 4 K2 = EFFECT OF LOAD ON PREDICTED BEARING L10 LIFE

When Calculated Idler Load (CIL) is less than CEMA load rating of series idler selected, the bearing L10 life will increase.

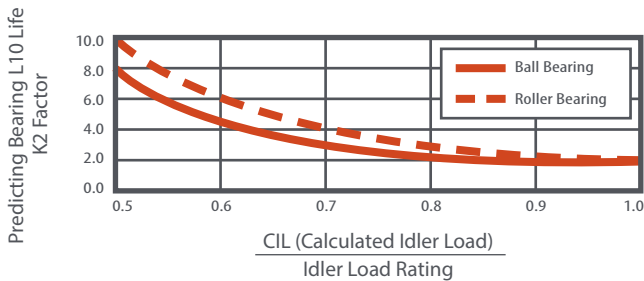

Figure 2-5 Effect of Load on Predicted Bearing L10 Life

## STEP NO. 5 K3A = EFFECT OF BELT SPEED ON PREDICTED BEARING L10 LIFE

CEMA L10 life ratings are based on 500 rpm. Slower speeds increase life and faster speeds decrease life. Figure 2-6 shows this relationship.

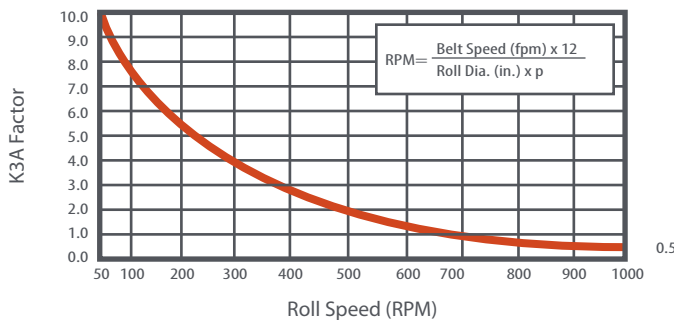
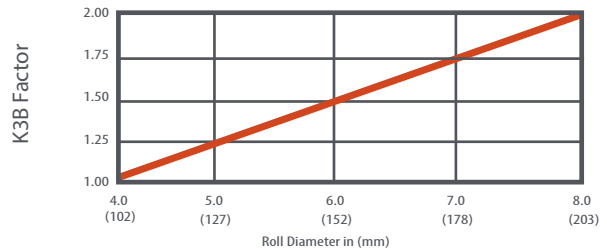

Figure 2-6 Effect of Belt Speed on Predicted Bearing L10 Life

## STEP NO. 6 K3B= EFFECT OF ROLL DIAMETER ON PREDICTED BEARING L10 LIFE

For a given belt speed, using larger diameter rolls will increase idler L10 life adjustments for various roll diameters using 4" diameter as a value of 1.0. Percent life increase can be calculated for each roll diameter increase.

Example: 1.5 for 6" diameter or 1.25 for 5" diameter= 1.20 or 20% increase in L10 life.



Note: In addition to increased predicted bearing L10 life, larger diameter rolls can increase idler wear life.

Figure 2-7 K3B= Effect of Roll Diameter on Predicted Bearing L10 Life (Based on the same belt speed)

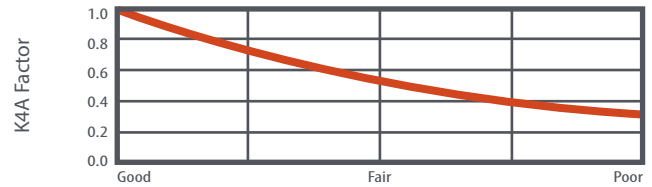

Figure 2-8 K4A= Effect of maintenance on potential idler life

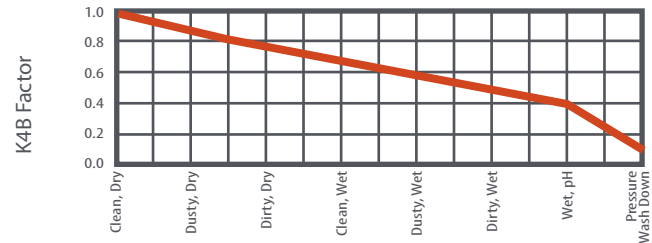

Figure 2-9 K4B= Effect of environment on potential idler life

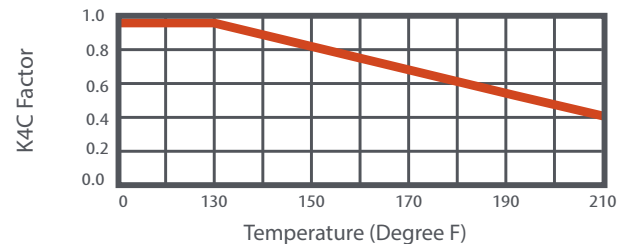

Figure 2-10 K4C= Effect of operating temperature on potential idler life

Based on collective application experience by CEMA idler manufacturers these conditions are important in determining potential idler life. However, exact mathematical basis is subjective so contact your CEMA idler manufacturer for assistance.

# IDLER SELECTION PROCEDURE

**TABLE 2-11 LOAD RATINGS FOR CEMA B IDLERS, LBS.**

BELT WIDTH (INCHES)	TROUGHED ANGLE			SINGLE ROLL RETURN
	20°	35°	45°	
18	410	410	410	220
24	410	410	410	190
30	410	410	410	165
36	410	410	396	155
42	390	363	351	140
48	381	353	342	125

**TABLE 2-12 LOAD RATINGS FOR CEMA C IDLERS, LBS.**

BELT WIDTH (INCHES)	TROUGHED ANGLE			SINGLE ROLL RETURN	TWO ROLL VEE RETURN
	20°	35°	45°		
18	900	900	900	475	-
24	900	900	900	325	500
30	900	900	900	250	500
36	900	837	810	200	500
42	850	791	765	150	500
48	800	744	720	125	500
54	750	698	675	*	500
60	700	650	630	*	500

\*Use CEMA D Return Idler.

**TABLE 2-13 LOAD RATINGS FOR CEMA D IDLERS, LBS.**

BELT WIDTH (INCHES)	TROUGHED ANGLE			SINGLE ROLL RETURN	TWO ROLL VEE RETURN
	20°	35°	45°		
24	1200	1200	1200	600	-
30	1200	1200	1200	600	-
36	1200	1200	1200	600	850
42	1200	1200	1200	500	850
48	1200	1200	1200	425	850
54	1200	1116	1035	375	850
60	1150	1070	1035	281	850
66	-	-	-	215	850
72	1050	977	945	155	850
78	-	-	-	125	850

**TABLE 2-14 LOAD RATINGS FOR CEMA E IDLERS, LBS.**

BELT WIDTH (INCHES)	TROUGHED ANGLE			SINGLE ROLL RETURN
	20°	35°	45°	
36	1800	1800	1800	1000
42	1800	1800	1800	1000
48	1800	1800	1800	1000
54	1800	1800	1800	925
60	1800	1800	1800	850
66	-	-	--	775
72	1800	1800	1800	700
78	-	-	-	625
84	1800	1674	1620	550
90	-	-	-	475
96	1750	1628	1575	400
102	-	-	-	250

**TABLE 2-15 LOAD RATINGS FOR CEMA F IDLERS, LBS.**

BELT WIDTH (INCHES)	TROUGHED ANGLE			SINGLE ROLL RETURN
	20°	35°	45°	
60	3000	3000	3000	1500
72	3000	3000	3000	1200
84	3000	3000	3000	900
96	2800	2800	2800	600

Notes for Tables 2-11 through 2-16

1. Troughing idler load ratings are for three equal length rolls.
2. Load ratings also apply for impact rolls.
3. Troughing idler load ratings are based on a load distribution of 70% on center roll and 15% on each end roll for all trough angles.
4. CEMA B and C ratings based on min. L10 of 30,000 hours at 500 RPM.
5. CEMA D and E ratings based on Min. L10 of 60,000 hours at 500 RPM.

# IDLER SELECTION PROCEDURE

**TABLE 2-16 LOAD RATINGS FOR CEMA PICKING IDLERS,**

BELT WIDTH	CEMA C	CEMA D	CEMA E
24	475	600	-
30	475	600	-
36	325	600	1260
42	250	600	1200
48	200	530	1000
54	150	440	1000
60	125	400	1000
66	-	-	1000
72	-	280	925
84	-	-	775
96	-	-	625

**TABLE 2-17 LOAD RATINGS FOR CEMA LIVE SHAFT IDLERS,**

BELT WIDTH	CEMA C	CEMA D	CEMA E
18	1200	-	-
24	1200	1400	2100
30	1200	1400	2100
36	1200	1400	2100
42	1100	1400	2100
48	1000	1275	2100
54	875	1150	2100
60	780	1000	2100
72	-	850	2100
84	-	-	1825
96	-	-	1550

**TABLE 2-18 BEARING SIZE**

CEMA C	CEMA D	CEMA E
1 7/16"	1 15/16"	203

## TRAINING IDLERS

Self-aligning idlers operate effectively when empty belt tensions are 200-lbs./in. or less. When empty belt tensions exceed this range, the belt becomes too stiff and makes training difficult. Belt loaded at high tensions and which generate detraining forces due to off-loading cannot be re-aligned with self-aligning idlers. Self-aligning idlers work effectively at low belt tensions to overcome small amounts of idler skew, which make narrow belts easier to train. Self-aligning idlers are especially needed on low tension reversible belts. Conveyor belts that are 48" and wider usually do not need self-aligning idlers even at low belt tensions because the weight of the belt has more training force than is obtainable with a trainer.

The removal of one return idler on each side of a self-aligning return to increase conveyor belt wrap on the idler will increase its self-aligning capacity. An alternative in removing the return idlers is to raise the self-aligner above the return belt line.

When self-aligning return idlers are used, they should be no closer than 12 belt widths from terminals and should not be located on vertical curves.

SELF-ALIGNER SPACING	INDOOR	FOR WIND AND RAIN
In line at standard spacing	200 ft.	150 ft.
(Returns removed to obtain maximum training)	150 ft.	75-100 ft.

## BELT CARRYING CAPACITY

The carrying capacity of a belt conveyor depends upon belt width, belt speed, and idler troughing configuration. The following information and charts will help you in selecting the proper size and style of idler.

- Define the material and its characteristics: Refer to Table 3-1 for weights in Lbs per Cu. Ft. and surcharge angles for some bulk materials.
- Select belt speed: Refer to Table 3-2 for maximum recommended belt speeds. The most economical selection usually dictates the use of maximum belt speeds.
- Select required belt width: Using Table 3-3 and the correct surcharge angle for the material being handled, select a belt width. Table 3-3 gives theoretical carrying capacities with various belt widths and idler troughing angles. Table 3-3 is based on a belt speed of 100 FPM and a material weight of 100 lbs. Per Cu. Ft. Footnote (1) on the bottom of page 145 tells how to calculate the capacities for other belt speeds and material weights. When determining belt width, belt speed, and troughing configuration, select the narrowest belt that will handle the largest material lumps and transport the required capacity without exceeding the maximum recommended belt speed.

# IDLER SELECTION PROCEDURE

**TABLE 3-1 - CHARACTERISTICS OF COMMON BULK**

MATERIAL	WEIGHT (LBS/FT <sup>3</sup> )	SURCHARGE ANGLE °	MAX. CONVEYING ANGLE °
Ashes, Coal, Dry, - 3"	35-40	25-30	22
Cement, Portland	90-100	25	20
Cement, Clinker	75-80	20	18
Coal, Arthracite, Sized, 3/8" - 6"	55	12	16
Coal, Bitum., Slack	50	22	22
Coal, Bitum., ROM	50	20	18
Coke, Loose	25-30	15	20
Earth, Common, Loam, Dry	70-80	15-30	20
Earth, Clay, Dry	100-120	10-30	20
Earth, Moist	80-100	30	22
Gravel, Average, Blended	90-100	15-20	18
Gravel, Sharp	90-100	25	20
Gravel, Rounded	90-100	15	15
Iron Ore	135	20	22
Limestone, Crushed	85-90	25-30	20
Phosphate Rock	75-85	25	20
Salt, Coarse, Dry	40-45	10	20
Salt, Fine, Dry	70-80	15	22
Sand, Bank, Damp	110-120	20-30	22
Sand, Bank, Dry	90-110	10-20	15
Sand, Foundry, Shakeout	90	25	20
Sand, Silica, Dry	90-100	10-20	15
Sand, Saturated	110-130	0-15	15
Shale, Crushed	85-90	25	20
Slag, Furnace, Crushed	85-90	12	18
Slate, Crushed, - 1/2"	80-90	15	20
Soda Ash, Light	25-35	22	20
Soda Ash, Heavy	55-65	17	20
Sulphur, Crushed, - 1/2"	50-65	20	20
Sulphur, Lumpy, - 3"	80-85	25	20
Wheat	45-48	8-15	16
Wood Chips	15-25	30	25

**TABLE 3-2 - MAXIMUM RECOMMENDED BELT SPEEDS**

MATERIAL BEING CONVEYED	BELT SPEEDS (FPM)	BELT WIDTH (IN.)
Grain or other free-flowing, nonabrasive material	400	18
	600	24-30
	800	36-42
	1000	48-96
Coal, damp clay, soft ores, overburden and earth, fine-crushed stone	600	18
	800	24-36
	1000	42-60
	1200	72-96
Heavy, hard, sharp-edged ore, coarse-crushed stone	400	18
	600	24-36
	800	Over 36
Foundry sand, prepared or damp; shakeout sand with small cores, with or without small castings (not hot enough to harm belting)	350	Any Width
Prepared foundry sand and similar damp (or dry abrasive) materials discharged from belt by rubber-edged plows	200	Any Width
Nonabrasive materials discharged from belt by means of plows - except wood pulp, where 300 to 400 preferable	200	Any Width
Feeder belts, flat or troughed, for feeding fine, nonabrasive, or mildly abrasive materials from hoppers and bins.	50 to 100	Any Width

**TABLE 3-3 - MAXIMUM BELT CAPACITIES**

BW (IN.)	Troughed Angle	MAX BELT CAPACITY (TPH)					MAX. MATERIAL (IN.) FOR 20° SURCHARGE	
		Surcharge Angle					All lumps uniform size	Mixed 10% lumps 90% fines
		5°	10°	20°	25°	30°		
18	20°	-	-	50	56	63	4	4
	35°	Not Recommended						
	45°	Not Recommended						
24	20°	-	-	96	108	120	5	7
	35°	-	102	122	132	142	5	7
	45°	106	115	132	140	170	5	7
30	20°	-	-	157	175	195	6	10
	35°	-	167	200	215	232	6	10
	45°	175	187	215	230	244	6	10
36	20°	-	-	230	260	290	7	12
	35°	-	248	295	318	343	7	12
	45°	258	278	318	340	360	7	12
42	20°	-	-	320	360	400	8	14
	35°	-	344	408	442	475	8	14
	45°	358	386	440	470	500	8	14
48	20°	-	-	430	480	530	10	16
	35°	-	457	540	645	630	10	16
	45°	475	510	584	623	660	10	16

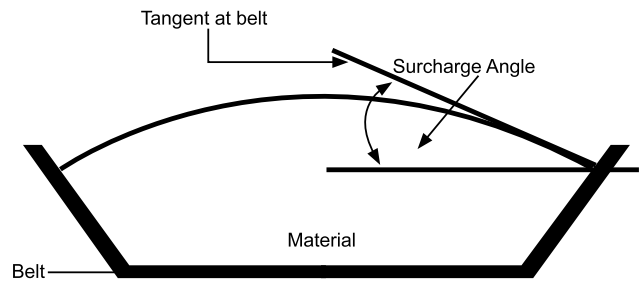

1. All capacities shown are for material weighing 100 lbs. per cu. ft. and moving on belt 100fpm. For other weights, capacity equals table capacity.

$$X \frac{\text{Wt./Cu. Ft.}}{100}$$

For other belt speeds, capacity equals table capacity (or calculated capacity).

$$X \frac{\text{fpm}}{100}$$

2. The surcharge angle is the angle formed between a horizontal line and a tangent to the material slope, both of which pass through the point where the slope meets the belt. Usually the surcharge angle is 10°-15° less than the angle of repose.

3. "Mixed with 50% fines" means at least half of the material must be less than one half the maximum material size.

**TABLE 4 SUGGESTED NORMAL SPACING OF BELT IDLERS**

BELT WIDTH (INCHES)	WEIGHT OF MATERIAL HANDLED (LBS/FT <sup>3</sup> )						RETURN IDLERS
	30	50	75	100	150	200	
18	5.5	5.0	5.0	5.0	4.5	4.5	10.0
24	5.0	4.5	4.5	4.0	4.0	4.0	10.0
30	5.0	4.5	4.5	4.0	4.0	4.0	10.0
36	5.0	4.5	4.0	4.0	3.5	3.5	10.0
42	4.5	4.5	4.0	3.5	3.0	3.0	10.0
48	4.5	4.0	4.0	3.5	3.0	3.0	10.0
54	4.5	4.0	3.5	3.5	3.0	3.0	10.0
60	4.0	4.0	3.5	3.0	3.0	3.0	10.0
72	4.0	3.5	3.5	3.0	2.5	2.5	8.0
84	3.5	3.5	3.0	2.5	2.5	2.0	8.0
96	3.5	3.5	3.0	2.5	2.0	2.0	8.0

# TERMS AND CONDITIONS

SUPERIOR INDUSTRIES, LLC (d/b/a Superior Equipment and as Superior Components)

1. **OFFER AND ACCEPTANCE.** Superior Industries, LLC's ("Seller") acceptance of Buyer's order to purchase products is expressly made conditional on assent to these Terms and Conditions, which along with the Sales Order constitute a binding "Contract" between the parties. This Contract constitutes the complete and final agreement between Seller and Buyer for the products. Any additional or different terms or conditions contained in any document furnished by Buyer, including but not limited to, any purchase order or any acknowledgment, are deemed to be material and are hereby objected to and rejected by Seller. If such agreement shall be deemed an offer or counter-offer by Buyer, Seller expressly rejects such offer or counter-offer and limits acceptance to these Contract terms and expressly objects to any different or additional terms proposed by Buyer. Any actual performance by Buyer or Seller thereafter shall be deemed a renewal of the offer contained in this Contract and acceptance of this Contract without change. In the event of a conflict between the terms of this Contract and the terms of any other document, the terms of this Contract shall control. This offer to purchase Seller's products is valid for thirty (30) days from the date of the Sales Order.

2. **PAYMENT TERMS.** All prices specified in this Contract are FOB Seller's designated location which constitutes delivery. All risk of damage to or loss of the products from any cause whatsoever shall pass to Buyer upon delivery, even if Seller arranges for shipment of the product. Unless otherwise expressly provided on the reverse hereof, payment shall be made within thirty (30) days from the earlier of the date of delivery or the date of an invoice, without discount. Any discount which may be expressly provided on the reverse hereof applies to the sale price of the products at the shipping point, and does not apply to any charges made for taxes, storage, loading or transportation. All payments shall be made in United States dollars. Interest will be charged at the rate of eighteen percent (18%) per annum, or the maximum interest rate allowable by applicable law, whichever is lower, on all unpaid invoices. Buyer shall pay all taxes and charges of any nature imposed by any federal, state, or local governmental authority by reason of the sale or delivery of the products whether levied or assessed against Seller, Buyer, or the products. Such applicable taxes or charges, if not included in this Contract, shall be invoiced separately. If, in Seller's opinion, reasonable doubt exists as to Buyer's financial condition, Seller may, at any time and without prejudice to any other remedies, suspend or terminate performance of any order, decline to ship, stop any material in transit, or require full or partial payment by Seller in advance.

3. **DELIVERY.** Any delivery or promise date indicated on the Sales Order is an estimate of the date Seller believes the products will be available for delivery, provided, however, Seller shall not be responsible for any delays in delivery.

#### 4. WARRANTY.

a. **Limited Warranty; Exclusion of Third Party Components.** Subject to the terms, conditions and limitations contained herein, Seller warrants only to the original Buyer that (a) Seller's new equipment products and Seller's new component products will not fail to operate in accordance with their respective specifications due to defects in material or workmanship during the period which ends two (2) years from the date of delivery, normal wear and tear excluded, and (b) Seller's new equipment products will not incur a failure of their respective structural components (i.e., trusses) due to defects in material or workmanship at any time during the period which ends five (5) years from the date of delivery, normal wear and tear excluded. The foregoing periods are sometimes referred to as "original warranty periods." The foregoing limited warranty does not apply to any part, portion or component of any product which is manufactured by a third-party ("Third-Party Component").

b. **DISCLAIMER OF ALL OTHER WARRANTIES, EXPRESS, IMPLIED OR STATUTORY.** THE LIMITED WARRANTY SET FORTH IN THE FOREGOING PARAGRAPH IS THE SOLE AND EXCLUSIVE WARRANTY WITH RESPECT TO THE PRODUCTS. SELLER MAKES NO OTHER EXPRESS WARRANTY OF ANY KIND OR NATURE AS TO THE PRODUCTS OR THEIR PERFORMANCE EXCEPT FOR THOSE LIMITED WARRANTIES EXPRESSLY SET FORTH IN THE FOREGOING PARAGRAPH AND SPECIFICALLY DISCLAIMS ANY AND ALL REPRESENTATIONS OR WARRANTIES OF ANY KIND OR NATURE

CONCERNING THE PRODUCTS, INCLUDING, BUT NOT LIMITED TO, ANY REPRESENTATION OR WARRANTY THAT THE PRODUCTS COMPLY WITH ANY LAW, RULE OR REGULATION. SELLER MAKES NO WARRANTIES WITH RESPECT TO ANY THIRD PARTY COMPONENT AND SELLER SPECIFICALLY SELLS SUCH THIRD-PARTY COMPONENTS "AS IS" WITHOUT ANY WARRANTY. FURTHER, SELLER MAKES NO IMPLIED WARRANTY OF ANY KIND OR NATURE WITH RESPECT TO ITS PRODUCTS OR ANY THIRD-PARTY COMPONENT AND SPECIFICALLY DISCLAIMS ANY AND ALL IMPLIED WARRANTIES, INCLUDING, BUT NOT LIMITED TO, ANY AND ALL IMPLIED WARRANTIES OF MERCHANTABILITY, FITNESS FOR A PARTICULAR PURPOSE, NON-INFRINGEMENT, OR COMPLIANCE WITH ANY FEDERAL, STATE OR LOCAL LAW, RULE OR REGULATION. IN ADDITION, SELLER EXPRESSLY DISCLAIMS TO THE FULLEST EXTENT ALLOWED BY LAW, RULE OR REGULATION ANY WARRANTY PROVIDED UNDER ANY FEDERAL, STATE OR LOCAL LAW, RULE OR REGULATION.

c. **Terms and Conditions of Warranty; Voiding of Warranty; Notice Requirements.** The limited warranties set forth above shall be null and void if (a) any alterations or modifications are made to a product, (b) a product is not maintained in strict compliance with the maintenance requirements set forth in the maintenance manual for such product or otherwise provided to Buyer of such product, (c) any repairs are made to a product which are not authorized by Seller in writing, (d) any failure of a product to comply with the above limited warranty is not reported to Seller in writing within thirty (30) days of the date such failure first occurs, (e) a product is operated after the failure of any warranty first occurs, (f) a product is used for any purpose other than for the purpose for which it was manufactured, (g) a product is not operated in strict compliance with the terms and conditions set forth in any operating manual for the product (including but not limited to exceeding the load bearing capacity of the product), (h) a product is abused or damaged, (i) Buyer fails to deliver the product to Seller for inspection and testing if requested by Seller or Buyer disposes of the product or any part or component on or before the sixtieth (60th) day after sending a written claim under the warranty to Seller, or (j) such failure of the limited warranty results from a failure of any Third-Party Component.

d. **Course of Dealing; Course of Performance; Usage of Trade.** No course of dealing or course of performance of Seller with respect to the products sold under this Contract or with respect to any of its products to whomsoever sold and no usage of trade shall be considered in interpreting this Contract or any part thereof and none of the foregoing shall be considered a waiver or modification of any such terms, conditions, disclaimers or limitation of the limited warranties or disclaimers contained in this Contract. No statement, whether written or oral, made by any employee, sales person, distributor, agent or contractor of Seller which is not set forth in this Contract shall be considered a representation or warranty with respect to any product, its specifications or its performance and all such statements are hereby disclaimed.

e. **Exclusive Remedies for Breach of Warranty.** The sole and exclusive remedy for any failure of any product to comply with the limited warranty set forth above or any other warranty imposed upon Seller by law, if any, shall, at the election of Seller, in its sole discretion, be either (a) the repair or replacement of the product or component which failed to comply with such warranty or (b) the refund of the purchase price of the product. Buyer is responsible for all labor costs in connection with the repair or replacement of any equipment or component product; however, Seller will be responsible for its own labor performed in connection with any repair of equipment products at Seller's location. Except as provided below, any repair or replacement shall carry the same warranty as the original product but only for the remainder of the original warranty period.

Buyer's exclusive remedy with respect to any claim arising out of or as a result of Third-Party Component shall be against the third-party manufacturer.

f. **Warranty Claims; Notice Requirement; Limited Time to Bring Claims.** Any and all claims under the above limited warranty shall be made to Seller only in writing and not later than thirty (30) days after the date the product first fails to comply with the above limited warranty but in no event later than the expiration of the original warranty period with respect to which the claim is being made. Any claim under the above

# TERMS AND CONDITIONS

limited warranty made after such period for making a claim shall be null and void. After receiving written notice of the warranty claim, Seller shall determine whether to (a) repair or replace the product or part or (b) refund the purchase price of the product. Seller may require Buyer to return any product or part thereof which Buyer claims to be defective to Seller at Buyer's cost for inspection as a condition to any claim under the above limited warranty. No product or part may be returned to Seller without Seller's prior written authorization. If a product which is returned is determined by Seller in its sole discretion not to have failed to comply with the limited warranty, Buyer shall pay costs of removal, repair and/or replacement for such product. If a product which is returned is determined by Seller in its sole discretion to have failed to comply with the limited warranty, Seller shall pay for all repair and/or replacement costs for such product (or refund the purchase price if so elected by Seller) and Seller shall reimburse Buyer for the reasonable costs of shipping the product or component to Seller.

g. Limitation on Liability for Breach of Warranty and Other Claims. If the warranty and the remedy for any failure of any product to comply with any warranty are deemed for any reason to fail their intended purpose, Seller's liability for any failure of any product to comply with any such warranty, together with any and all other liability, if any, arising out of or in connection with such product, including, but not limited to, all claims, whether in contract, tort, or otherwise, arising out of, connected with, or resulting from the manufacture, sale, delivery, resale, repair, replacement, or use of the product, shall not exceed the purchase price for such product. In no event shall Seller be responsible or liable to Buyer or any third party under any circumstances for any indirect, consequential, special, punitive or exemplary, damages or losses, including, but not limited to, damages for loss of profits, goodwill, use of the product or any other equipment or other intangible losses which may be incurred in connection with the product regardless of the type of claim or the nature of the cause of action, even if Seller has been advised of the possibility of such damage or loss. Any and all claims that Buyer has against Seller, whether or not Buyer is aware of such claims, must be brought by Buyer within thirty (30) days after the date that such claim first arose, but in any event within the applicable warranty period set forth above. Any claim not brought by Buyer within the applicable thirty (30) day period shall be deemed null and void.

5. INDEMNIFICATION. Buyer will indemnify and hold harmless Seller, its affiliates and their respective officers, directors, employees, agents and other representatives and defend any action brought against same with respect to any claims, judgments, actions, suits, demands, damages, liabilities, costs or expenses (including, but not limited to, reasonable attorneys' fees and legal expenses) associated with or arising from the ownership, use or operation of the products by Buyer or any third party, including without limitation, product liability, an international, federal or state occupational safety and health statute, or any other governmental regulations or laws.

6. TERMINATION OF PERFORMANCE. Buyer may cancel its order only with the written consent of Seller and upon terms that will indemnify Seller from any loss, damage and expense arising from such cancellation. Seller may terminate this Contract pursuant to Sections 2 and/or 11 hereof, and in such event, Seller shall have no further liability to produce or ship any products hereunder and shall have no liability for damages to Buyer or any third party.

7. TECHNICAL ADVICE. No obligation or liability shall arise out of Seller's rendering of technical advice in connection with Buyer's order of products. Any technical advice furnished, or recommendation made by Seller or any employee or representative of Seller, concerning any use or application of any products or parts furnished under this Contract is believed to be reliable, but Seller makes no warranty, express or implied, of results to be obtained. Buyer assumes all responsibility for loss or damage resulting from the handling or use of any such products or parts in accordance with such technical advice or recommendation. The selection of the products ordered, or design of any custom products, shall be Buyer's sole and ultimate responsibility, and Seller shall have no liability whatsoever for any design defects of custom products, or if the products ordered are unsuitable for Buyer's intended use. Any advice or assistance provided by Seller to Buyer in connection with Buyer's

selection or design of the products is at Buyer's risk, and Seller makes no representation or warranty whatsoever in connection with such advice or assistance.

8. ASSIGNMENT. Buyer shall not assign its rights or obligations under this Contract without the prior written consent of Seller, which consent may be withheld for any reason in the sole discretion of Seller. Any attempt at such assignment by Buyer without the prior written consent of Seller shall be deemed null and void. This Contract will be binding upon the parties hereto, and their successors and permitted assigns.

9. SECURITY INTEREST OF SELLER. Title to the products will not pass to Buyer until all required payments have been made to Seller. Until the purchase price and all other applicable costs and expenses are paid in full, Seller reserves a purchase money security interest in the products and the proceeds therefrom, and Seller thereby possesses the rights of a secured party under the Uniform Commercial Code. Upon Seller's request, Buyer shall execute all necessary financing statements and other documents evidencing this security interest with the appropriate state and local authorities. Seller is entitled to and is hereby granted reasonable access to Buyer's locations as necessary to exercise its remedies as a secured party.

10. GOVERNING LAW. This Contract shall be construed, interpreted, and governed by the laws of the State of Minnesota without regard to its conflict of laws principles. The exclusive forum for any disputes arising out of or relating to this Contract shall be any federal or state court sitting in the State of Minnesota. The parties irrevocably consent to such exclusive jurisdiction in such courts and to the proper venue therein.

11. FORCE MAJEURE. Seller does not assume the risk of and shall not be liable for failure to perform any obligation relating to the products caused by civil insurrection, war, fire, strike, labor stoppages or other labor disturbances, acts of God, acts or omissions of Buyer, acts or omissions of the United States Government, floods, epidemics, freight embargoes, shortages of fuel, energy or materials, failure of suppliers or subcontractors to satisfactorily meet scheduled deliveries, or any other cause beyond the reasonable commercial control of Seller.

12. NOTICES. Any notices, consents or other communications required or permitted under this Contract must be in writing and delivered personally, overnight air courier, registered or certified mail or facsimile. Unless otherwise stated in this Contract, notices, consents or other communication will be deemed received (a) on the date delivered, if delivered personally or by facsimile transmission; (b) on the next business day if sent via overnight air courier; or (c) three (3) business days after being sent, if sent by registered or certified mail.

13. SEVERABILITY; WAIVER. The invalidity or unenforceability of any provision of this Contract shall not affect the validity or enforceability of any other provision of this Contract. No waiver of any of the provisions of this Contract shall be deemed, or shall constitute a waiver of any other provision, whether or not similar, nor shall any waiver constitute a continuing waiver. No waiver shall be binding unless executed in writing by the party making the waiver. The Section headings included herein are for the convenience of the parties only and in no way alter, modify, amend, limit or restrict the contractual obligations of the parties.

14. NO THIRD-PARTY BENEFICIARIES; SETOFF. Nothing in this Contract is intended to, or shall, create any third-party beneficiaries, whether intended or incidental, and neither party shall make any representations to the contrary. Seller shall have the right to deduct from any sums it owes to Buyer, any sums or the value of any obligation owed by Buyer to Seller.

15. ENTIRE AGREEMENT. The terms set forth herein constitute the sole terms and conditions of the Contract between Buyer and Seller. Notwithstanding the foregoing or any other term of this Contract, to the extent this Contract conflicts with the terms or conditions of any written distributor agreement between the parties, the written distributor agreement shall control. No other warranty, term, condition or understanding, whether oral or written shall be binding upon Seller, unless hereafter expressed in writing, approved and signed by Seller.

16. SURVIVAL. The provisions of Sections 3, 4, 5, and 7 through 16 shall survive the termination and performance of this Contract.



[SUPERIOR-IND.COM](http://SUPERIOR-IND.COM)



ROCK FACE TO  
**LOAD OUT**<sup>™</sup>

[superior-ind.com](http://superior-ind.com)

2023-05SPT1227EN-12