

Bearing Accessories and Pillow Blocks Catalog

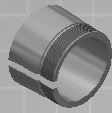

ADAPTERS

ADAPTERS FOR BEARING SERIES 230, 231, 12, 222
 ADAPTERS FOR BEARING SERIES 232, 13, 223
 ADAPTER SLEEVES SERIES S00, S100
 ADAPTER SLEEVES SERIES S30, S31, S32
 METRIC ADAPTERS SERIES H2, H3, H23, H30, H31, H32, H39
 METRIC ADAPTER SLEEVES SERIES H2, H3
 METRIC ADAPTER SLEEVES SERIES H30
 METRIC ADAPTER SLEEVES SERIES H31, H32
 METRIC ADAPTER SLEEVES SERIES H23, H39

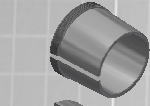

WITHDRAWAL SLEEVES

WITHDRAWAL SLEEVES SK & ASK-SERIES DIMENSIONS
 WITHDRAWAL SLEEVES METRIC AH-SERIES



REMOVAL NUTS

REMOVAL NUTS RN SERIES DIMENSIONS

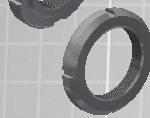

LOCKNUTS

LOCKNUTS N-00 SERIES DIMENSIONS
 LOCKNUTS N-00 SERIES SHAFT DIMENSIONS
 LOCKNUTS N-000 SERIES DIMENSIONS
 LOCKNUTS N-000 SERIES SHAFT DIMENSIONS
 LOCKNUTS PRN/PRL-00 SERIES DIMENSIONS (precision)
 LOCKNUTS PRT-00 SERIES DIMENSIONS (precision thin)
 LOCKNUTS SN-00 SERIES DIMENSIONS (self-locking)
 LOCKNUTS SNH-00 SERIES DIMENSIONS (self-locking/high temperature)
 LOCKNUTS NHE-00 SERIES DIMENSIONS (wide series)
 LOCKNUTS NIN-00 SERIES DIMENSIONS (16 threads/inch)
 LOCKNUTS NTH-00 SERIES DIMENSIONS (thin series)
 LOCKNUTS KM-00 SERIES DIMENSIONS (metric design)



LOCKWASHERS

LOCKWASHERS W-00 AND W-000 SERIES DIMENSIONS
 LOCKWASHERS PRW-00 SERIES DIMENSIONS (precision)
 LOCKWASHERS PRWT-00 SERIES DIMENSIONS (precision thin)
 LOCKWASHERS TW-000 SERIES DIMENSIONS (thick)
 LOCKWASHERS WTH-00 & WIN-00 SERIES DIMENSIONS (thin & inch series)
 LOCKWASHERS MB-00 SERIES DIMENSIONS (metric design)



LOCKPLATES

LOCKPLATES P-000 LOCKPLATE SERIES DIMENSIONS



PILLOW BLOCKS

PILLOW BLOCKS CAST IRON SAF-200 SERIES (straight bore housing)
 PILLOW BLOCKS CAST IRON SAF-300 SERIES (straight bore housing)
 PILLOW BLOCKS CAST IRON SAF-500 SERIES (tapered bore housing)
 PILLOW BLOCKS CAST IRON SAF-600 SERIES (tapered bore housing)
 PILLOW BLOCKS CAST IRON SAF-230 SERIES (tapered bore housing)
 PILLOW BLOCKS STEEL SAFS-200 SERIES (straight bore housing)
 PILLOW BLOCKS STEEL SAFS-500 SERIES (tapered bore housing)



MILITARY STANDARD

MILITARY STANDARD LOCKNUTS MS 1722 SERIES
 MILITARY STANDARD LOCKWASHERS MS 1722 SERIES
 MILITARY STANDARD LOCKNUTS MS 19067 SERIES
 MILITARY STANDARD LOCKWASHERS MS 19069 SERIES
 MILITARY STANDARD LOCKNUTS MS 19068 SERIES
 MILITARY STANDARD LOCKWASHERS MS 19070 SERIES



SPANNER WRENCHES

SPANNER WRENCHES

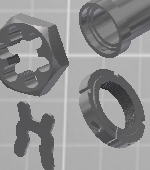

RETHREADING DIES

RETHREADING DIES DRT-SERIES

CLAMP NUTS

CLAMP NUTS NC-SERIES

X WASHERS

X-WASHERS





*Bearing Accessories and
Pillow Blocks Catalog*



Welcome to Standard Locknut, LLC

We are recognized in the bearing industry as the premier supplier of bearing accessories including adapters, locknuts, lockwashers, seal rings, adapter sleeves and, of course, split pillow blocks.

Since 1948, Standard Locknut, LLC has been supporting key industries like the bearing, oil and gas, aerospace, mining, chemical, heavy duty and off-road, with the highest quality and on-time delivery of bearing accessories.

Made in the USA, you can count on it.

	
Standard Locknut, LLC Westfield, IN (800) 783-6887	 Made in the USA

We supply our standard split pillow blocks to all corners of the globe. Typically used with a spherical bearing, the housing may be your most important purchase.

It all starts with the castings. We control our quality of pillow blocks by using castings from molds designed and owned by us.

We supply the industry in sizes from 511 up to 056 in SAF and SAFS. Cast iron, ductile iron or steel, along with the LER seals, we're prepared to support your pillow block needs.

We also machine customer-supplied pillow blocks, both standard and specials, for those unique and demanding applications.

Either way, our customers have come to depend on us for our reliability, quality and delivery.

Critical to any successful bearing installation is the means of securing the bearing to the shaft. That's where we come in.

Our line of locking devices includes adapters and sleeves, washers, locknuts and lockwashers. Available in metric and inch series, our accessories are manufactured to ABMA, SAE and ABEC standards.



Standard Locknut, LLC

*"We will meet or exceed all customer expectations
and continually improve everything we do."*

CONTACT US TODAY

Sales: (800) 783-6887

Fax: (800) 573-5515

Email: sales@stdlocknut.com



www.standardlocknut.com

**1045 East 169th Street
Westfield, IN 46074**

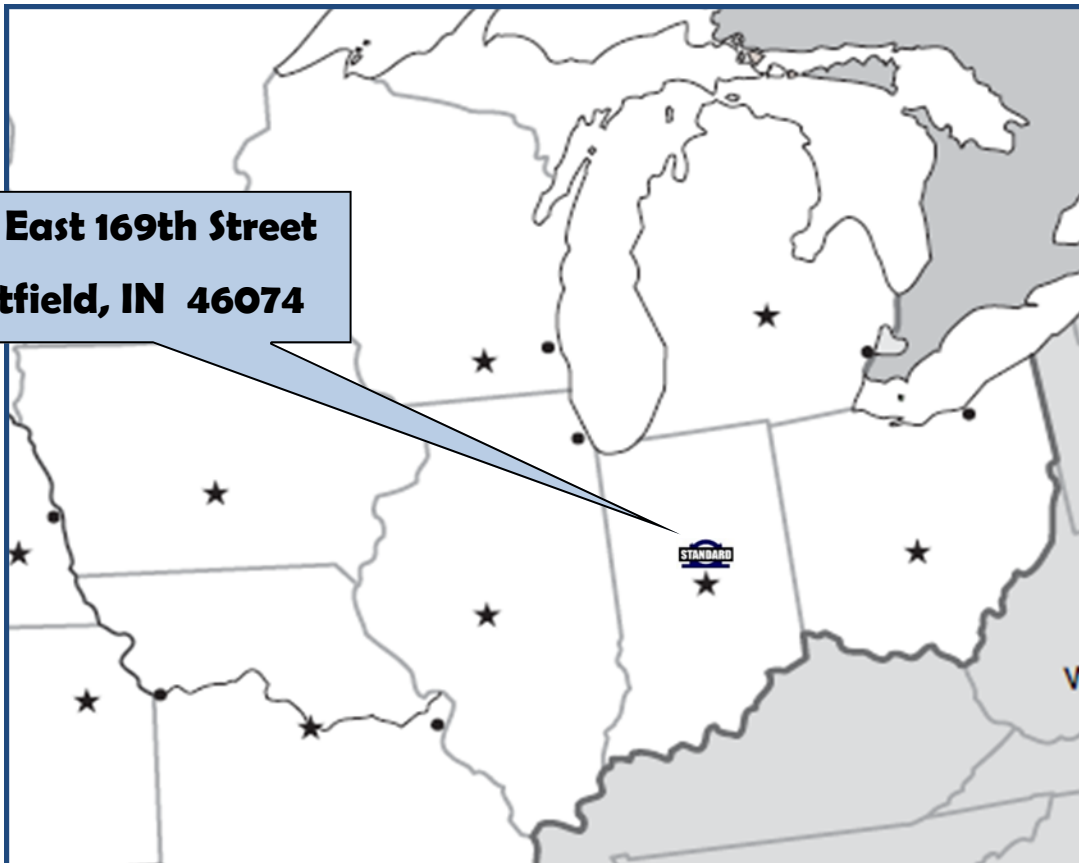



Adapter Series

Bearing Accessories

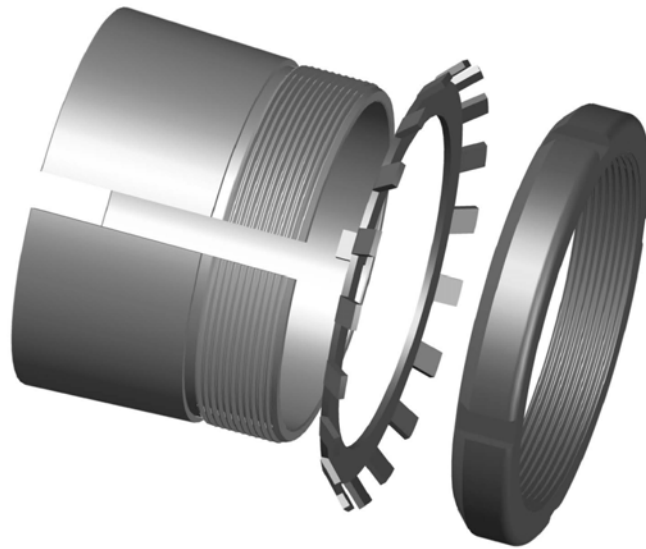

ADAPTER SERIES

FOR BEARING SERIES 230, 231, 12, 222

For tapered bore assembly

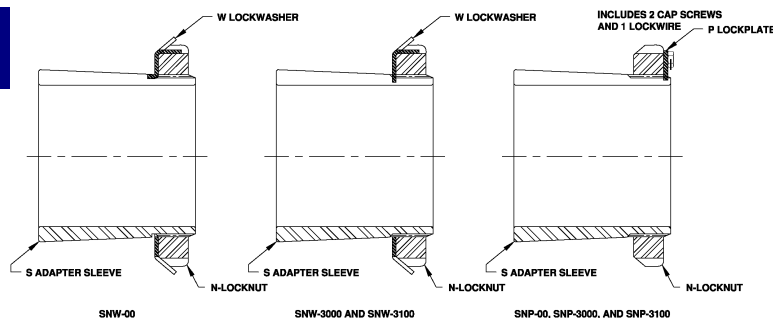

BEARING NOMINAL BORE (mm)	230			231			230 & 231			12			222			12 & 222		
	ADAPTER UNIT		ADAPTER UNIT	ADAPTER UNIT		ADAPTER UNIT	LOCKNUT	LOCKING	ASSEMBLY	ASSEMBLY	SLEEVE	ADAPTER UNIT		ADAPTER UNIT		LOCKNUT	LOCKING	
	ASSEMBLY NO.	ASSEMBLY WT. (LB.)	SLEEVE NO.	ASSEMBLY NO.	ASSEMBLY WT. (LB.)	SLEEVE NO.	NO.	DEVICE NO.	NO.	WT. (LB.)	NO.	NO.	WT. (LB.)	NO.	NO.	NO.	DEVICE NO.	
20									SNW-04		S-04							
25									SNW-05	0.17	S-05							
30									SNW-06	0.24	S-06							
35									SNW-07	0.32	S-07	SNW-07	0.32	S-07	N-07	W-07		
40									SNW-08	0.42	S-08	SNW-08	0.42	S-08	N-08	W-08		
45									SNW-09	0.55	S-09	SNW-09	0.55	S-09	N-09	W-09		
50									SNW-10	0.67	S-10	SNW-10	0.67	S-10	N-10	W-10		
55									SNW-11	0.77	S-11	SNW-11	0.77	S-11	N-11	W-11		
60									SNW-12	0.87	S-12	SNW-12	0.87	S-12	N-12	W-12		
65									SNW-13	1.01	S-13	SNW-13	1.01	S-13	N-13	W-13		
70									SNW-14	1.59	S-14	SNW-14	1.59	S-14	N-14	W-14		
75									SNW-15	1.83	S-15	SNW-15	1.83	S-15	AN-15	W-15		
80									SNW16	2.27	S-16	SNW-16	2.27	S-16	AN-16	W-16		
85									SNW-17	2.60	S-17	SNW-17	2.60	S-17	AN-17	W-17		
90									SNW-18	3.02	S-18	SNW-18	3.02	S-18	AN-18	W-18		
95												SNW-19	3.44	S-19	AN-19	W-19		
100									SNW-20	3.37	S-20	SNW-20	3.73	S-20	AN-20	W-20		
105																		
110				SNW-3122	4.25	S-22	N-022	W-022	SNW-22	4.81	S-22	SNW-22	4.81	S-22	AN-22	W-22		
120	SNW-3024	6.16	S-3024	SNW-3124	5.85	S-24	N-024	W-024				SNW-24	6.65	S-24	AN-24	W-24		
130	SNW-3026	7.50	S-3026	SNW-3126	8.35	S-26	N-026	W-026				SNW-26	9.70	S-26	AN-26	W-26		
140	SNW-3028	8.45	S-3028	SNW-3128	8.35	S-28	N-028	W-028				SNW-28	10.50	S-28	AN-28	W-28		
150	SNW-3030	9.80	S-3030	SNW-3130	13.50	S-30	N-030	W-030				SNW-30	16.00	S-30	AN-30	W-30		
160	SNW-3032	12.00	S-3032	SNW-3132	13.50	S-32	N-032	W-032				SNW-32	15.50	S-32	AN-32	W-32		
170	SNW-3034	13.50	S-3034	SNW-3134	16.00	S-34	N-034	W-034				SNW-34	19.50	S-34	AN-34	W-34		
180	SNW-3036	15.00	S-3036	SNW-3136	17.00	S-36	N-036	W-036				SNW-36	20.50	S-36	AN-36	W-36		
190	SNW-3038	16.50	S-3038	SNW-3138	19.50	S-38	N-038	W-038				SNW-38	23.50	S-38	AN-38	W-38		
200	SNW-3040	19.50	S-3040	SNW-3140	28.50	S-40	N-040	W-040				SNW-40	30.50	S-40	AN-40	W-40		
220	SNW-3044	24.50	S-3044	SNW-3144	32.00	S-44	N-044	W-044				SNW-44	32.50	S-44	N-044	W-44		
240	SNP-3048	32.00	S-3048	SNP-3148	37.50	S-48	N-048	P-48				SNP-48		S-48	N-048	P-48		
260	SNP-3052	41.00	S-3052	SNP-3152	44.00	S-52	N-052	P-52				SNP-52		S-52	N-052	P-52		
280	SNP-3056	45.50	S-3056	SNP-3156	46.50	S-3156	N-056	P-56										
300	SNP-3060	59.00	S-3060	SNP-3160	59.50	S-3160	N-060	P-60										
320	SNP-3064	65.00	S-3064	SNP-3164	74.00	S-3164	N-064	P-64										
340	SNP-3068	78.00	S-3068	SNP-3168	93.50	S-3168	N-068	P-68										
360	SNP-3072	86.00	S-3072	SNP-3172	120.00	S-3172	N-072	P-72										
380	SNP-3076	94.50	S-3076	SNP-3176	125.00	S-3176	N-076	P-76										
400	SNP-3080	100.00	S-3080	SNP-3180	140.00	S-3180	N-080	P-80										
420	SNP-3084	105.00	S-3084	SNP-3184	145.00	S-3184	N-084	P-84										
440	SNP-3088		S-3088	SNP-3188		S-3188	N-088	P-88										
460	SNP-3092		S-3092	SNP-3192		S-3192	N-092	P-92										
480	SNP-3096		S-3096	SNP-3196		S-3196	N-096	P-96										
500	SNP-30/500		S-30/500	SNP-31/500		S-31/500	N-500	P-500										
530	SNP-30/530		S-30/530	SNP-31/530		S-31/530	N-530	P-530										
560	SNP-30/560		S-30/560	SNP-31/560		S-31/560	N-560	P-560										
600	SNP-30/600		S-30/600	SNP-31/600		S-31/600	N-600	P-600										
630	SNP-30/630		S-30/630	SNP-31/630		S-31/630	N-630	P-630										
670	SNP-30/670		S-30/670	SNP-31/670		S-31/670	N-670	P-670										
710	SNP-30/710		S-30/710	SNP-31/710		S-31/710	N-710	P-710										
750	SNP-30/750		S-30/750	SNP-31/750		S-31/750	N-750	P-750										
800	SNP-30/800		S-30/800	SNP-31/800		S-31/800	N-800	P-800										
850	SNP-30/850		S-30/850	SNP-31/850		S-31/850	N-850	P-850										
900	SNP-30/900		S-30/900				N-900	P-900										
950	SNP-30/950		S-30/950				N-950	P-950										

ADAPTER SERIES



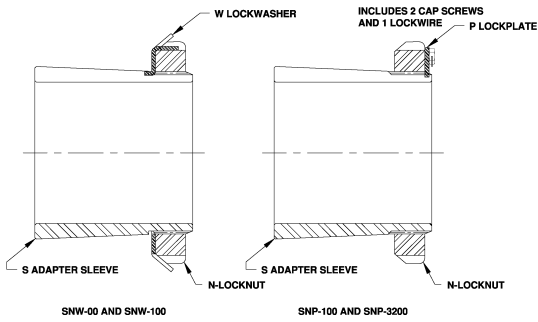

ADAPTER SERIES

FOR BEARING SERIES 232, 13, 223

For tapered bore assembly

BEARING	232			13			223			232, 13 & 223		
	NOMINAL BORE (mm)	ADAPTER UNIT ASSEMBLY NO.	ADAPTER UNIT ASSEMBLY WT. (LB.)	ADAPTER UNIT SLEEVE NO.	ADAPTER UNIT ASSEMBLY NO.	ADAPTER UNIT ASSEMBLY WT. (LB.)	ADAPTER UNIT SLEEVE NO.	ADAPTER UNIT ASSEMBLY NO.	ADAPTER UNIT ASSEMBLY WT. (LB.)	ADAPTER UNIT SLEEVE NO.	LOCKNUT NO.	LOCKING DEVICE NO.
20				SNW-04			S-04				N-04	W-04
25				SNW-05	0.17		S-05				N-05	W-05
30				SNW-06	0.24		S-06				N-06	W-06
35				SNW-07	0.32		S-07				N-07	W-07
40				SNW-08	0.42		S-08	SNW-108	0.50	S-108	N-08	W-08
45				SNW-09	0.55		S-09	SNW-109	0.62	S-109	N-09	W-09
50				SNW-10	0.67		S-10	SNW-110	0.80	S-110	N-10	W-10
55				SNW-11	0.77		S-11	SNW-111	0.93	S-111	N-11	W-11
60				SNW-12	0.87		S-12	SNW-112	1.06	S-112	N-12	W-12
65				SNW-13	1.01		S-13	SNW-113	1.23	S-113	N-13	W-13
70				SNW-14	1.59		S-14	SNW-114	1.59	S-114	N-14	W-14
75				SNW-15	1.83		S-15	SNW-115	2.32	S-115	AN-15	W-15
80				SNW-16	2.27		S-16	SNW-116	2.82	S-116	AN-16	W-16
85				SNW-17	2.60		S-17	SNW-117	3.20	S-117	AN-17	W-17
90				SNW-18	3.02		S-18	SNW-118	3.73	S-118	AN-18	W-18
95				SNW-19	3.44		S-19	SNW-119	4.23	S-119	AN-19	W-19
100	SNW-120	4.75	S-120	SNW-20	3.73	S-20	SNW-120	4.74	S-120	AN-20	W-20	
105				SNW-21	4.30	S-21				AN-21	W-21	
110	SNW-122	6.04	S-122	SNW-22	4.81	S-22	SNW-122	6.04	S-122	AN-22	W-22	
120	SNW-124	7.03	S-124				SNW-124	7.03	S-124	AN-24	W-24	
130	SNW-126	10.10	S-126				SNW-126	10.10	S-126	AN-26	W-26	
140	SNW-128	12.20	S-128				SNW-128	12.20	S-128	AN-28	W-28	
150	SNW-130	14.60	S-130				SNW-130	14.60	S-130	AN-30	W-30	
160	SNW-132	20.20	S-132				SNW-132	20.20	S-132	AN-32	W-32	
170	SNW-134	22.50	S-134				SNW-134	22.50	S-134	AN-34	W-34	
180	SNW-136	24.90	S-136				SNW-136	24.90	S-136	AN-36	W-36	
190	SNW-138	27.80	S-138				SNW-138	27.80	S-138	AN-38	W-38	
200	SNW-140	30.60	S-140				SNW-140	30.60	S-140	AN-40	W-40	
220	SNW-144	36.80	S-144				SNW-144	36.80	S-144	N-44	W-44	
240	SNP-148	48.50	S-148				SNW-148	48.50	S-148	N-048	P-48	
260	SNP-152	54.50	S-152				SNW-152	54.50	S-152	N-052	P-52	
280	SNP-3256	59.00	S-3256							N-056	P-56	
300	SNP-3260	68.50	S-3260							N-060	P-60	
320	SNP-3264	98.00	S-3264							N-064	P-64	
340	SNP-3268	105.00	S-3268							N-068	P-68	
360	SNP-3272	135.00	S-3272							N-072	P-72	
380	SNP-3276	145.00	S-3276							N-076	P-76	
400	SNP-3280	165.00	S-3280							N-080	P-80	
420	SNP-3284	195.00	S-3284							N-084	P-84	
440	SNP-3288		S-3288							N-088	P-88	
460	SNP-3292		S-3292							N-092	P-92	
480	SNP-3296		S-3296							N-096	P-96	
500	SNP-32/500		S-32/500							N-500	P-500	
530	SNP-32/530		S-32/530							N-530	P-530	
560	SNP-32/560		S-32/560							N-560	P-560	
600	SNP-32/600		S-32/600							N-600	P-600	
630	SNP-32/630		S-32/630							N-630	P-630	
670	SNP-32/670		S-32/670							N-670	P-670	
710	SNP-32/719		S-32/710							N-710	P-710	
750	SNP-32/750		S-32/750							N-750	P-750	



ADAPTER SERIES

ADAPTER SLEEVE SERIES

S00 SERIES FOR BEARING SERIES 12, 13, 222, 231

S100 SERIES FOR BEARING SERIES 223, 232

For tapered bore assembly

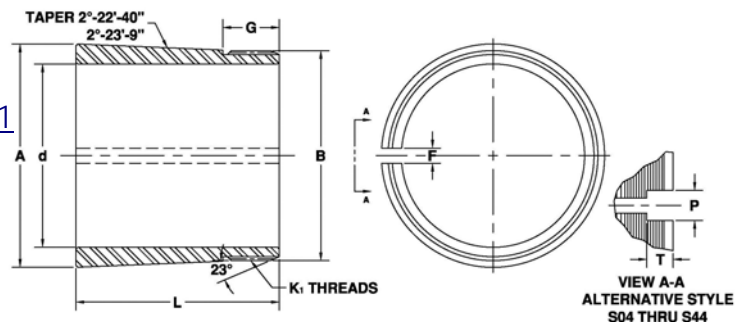

ADAPTER SLEEVE DIMENSIONS

SLEEVE NO.		BORE DIA.	SHARP CORNER DIA.		SLEEVE LENGTH		THREADS		THD. LENGTH	WIDTH	SLOT WIDTH	DEPTH
		d	A		L		MAJOR DIA. B		G	F	P	T
		MAX.	MIN.		MIN.		MAX.		MAX.	MIN.	MIN.	MIN.
S00	S100		S00	S100	S00	S100		K ₁				
S04	S104	0.692	0.855	1.082	1.224	1.460	0.781	32	0.531	0.07	0.240	0.691
S05	S105	0.754	1.052	1.082	1.259	1.617	0.969	32	0.570	0.07	0.240	0.741
S06	S106	0.942	1.256	1.292	1.343	1.779	1.173	18	0.632	0.07	0.240	0.822
S07	S107	1.192	1.459	1.499	1.449	1.922	1.376	18	0.664	0.07	0.240	0.863
S08	S108	1.317	1.659	1.702	1.494	2.005	1.563	18	0.672	0.08	0.365	0.874
S09	S109	1.442	1.863	1.909	1.574	2.123	1.767	18	0.672	0.08	0.365	0.874
S10	S110	1.692	2.070	2.122	1.755	2.384	1.967	18	0.734	0.08	0.365	0.954
S11	S111	1.942	2.273	2.329	1.835	2.506	2.157	18	0.739	0.08	0.365	0.961
S12	S112	2.067	2.480	2.535	1.979	2.649	2.360	18	0.770	0.08	0.365	1.001
S13	S113	2.192	2.683	2.739	2.090	2.761	2.548	18	0.802	0.08	0.365	1.043
S14	S114	2.317	2.894	2.950	2.264	2.935	2.751	18	0.802	0.08	0.365	1.043
S15	S115	2.442	3.090	3.155	2.286	3.074	2.933	12	0.905	0.12	0.365	1.177
S16	S116	2.692	3.293	3.362	2.366	3.194	3.137	12	0.905	0.12	0.428	1.177
S17	S117	2.942	3.497	3.566	2.476	3.302	3.340	12	0.936	0.12	0.428	1.217
S18	S118	3.192	3.700	3.776	2.636	3.543	3.527	12	1.020	0.12	0.428	1.326
S19	S119	3.317	3.904	3.982	2.750	3.692	3.730	12	1.051	0.12	0.428	1.367
S20	S120	3.442	4.107	4.199	2.859	3.961	3.918	12	1.083	0.12	0.428	1.408
S21	S121	3.692	4.314	4.412	2.977	4.157	4.122	12	1.083	0.12	0.428	1.408
S22	S122	3.942	4.524	4.619	3.196	4.338	4.325	12	1.145	0.15	0.428	1.488
S24	S124	4.192	4.937	5.035	3.456	4.638	4.716	12	1.176	0.15	0.428	1.529
S26	S126	4.442	5.350	5.452	3.752	4.972	5.106	12	1.239	0.15	0.552	1.611
S28	S128	4.942	5.757	5.869	3.971	5.313	5.497	12	1.301	0.15	0.740	1.692
S30	S130	5.192	6.167	6.282	4.231	5.611	5.888	12	1.364	0.15	0.740	1.774
S32	S132	5.442	6.584	6.696	4.568	5.910	6.284	8	1.520	0.15	0.740	1.976
S34	S134	5.942	6.997	7.109	4.837	6.178	6.659	8	1.551	0.24	0.865	2.017
S36	S136	6.442	7.404	7.522	5.028	6.446	7.066	8	1.583	0.24	0.865	2.058
S38	S138	6.942	7.814	7.939	5.251	6.748	7.472	8	1.614	0.24	0.865	2.098
S40	S140	7.192	8.221	8.355	5.474	7.085	7.847	8	1.676	0.24	0.990	2.179
S44	S144	7.942	9.041	9.153	5.891	7.277	8.628	8	1.708	0.24	0.990	2.220
S48	S148	8.942	9.878	9.994	6.628	8.099	9.422	6	1.989	0.30	1.125	0.500
S52	S152	9.442	10.734	10.832	7.583	8.764	10.192	6	2.135	0.30	1.188	0.500

ADAPTER SLEEVE SERIES



ADAPTER SLEEVE SERIES

[S3000 SERIES FOR BEARING SERIES 230](#)

[S3100 SERIES FOR BEARING SERIES 231](#)

[S3200 SERIES FOR BEARING SERIES 232](#)

For tapered bore assembly

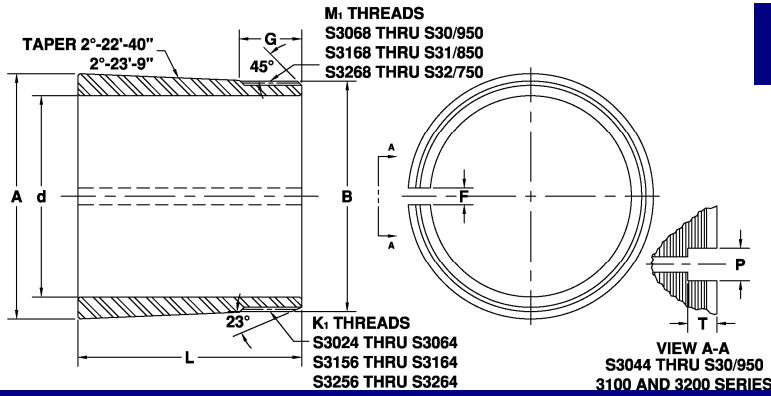

ADAPTER SLEEVE DIMENSIONS

SLEEVE NO.			BORE DIA.	SHARP CORNER DIA.			SLEEVE LENGTH		THREADS			SLOT				
S3000	S3100	S3200	d	A			L	IAJOR DIA	NO. PER INCH		THD. LENGTH	WIDTH	WIDTH	DEPTH		
			MAX.	MIN.	S3000	S3100	S3200	MIN.	B	K ₁	M ₁	G	F	P	T	
								MAX.			MAX.	MIN.	MIN.	MIN.		
S3024			4.192	4.890			2.937		4.716	12		1.260	0.146	0.428	1.638	
S3026			4.442	5.304			3.227		5.106	12		1.323	0.146	0.552	1.720	
S3028			4.942	5.701			3.330		5.497	12		1.385	0.146	0.740	1.800	
S3030			5.192	6.105			3.482		5.888	12		1.416	0.146	0.740	1.892	
S3032			5.442	6.512			3.701		6.284	8		1.478	0.146	0.740	1.921	
S3034			5.942	6.929			4.009		6.659	8		1.510	0.240	0.865	1.963	
S3036			6.442	7.346			4.327		7.066	8		1.541	0.240	0.865	2.003	
S3038			6.942	7.744			4.402		7.472	8		1.604	0.240	0.865	2.085	
S3040			7.192	8.161			4.740		7.847	8		1.666	0.240	0.990	2.166	
S3044			7.942	8.976			5.120		8.628	8		1.760	0.240	0.990	2.288	
S3048			8.942	9.771			5.422		9.442	6		1.978	0.302	1.125	0.500	
S3052			9.444	10.600			6.009		10.192	6		2.135	0.302	1.188	0.500	
S3056	S3156	S3256	10.444	11.394	11.526	11.624	6.181	7.756	8.937	11.004	6	2.229	2.229	0.302	1.250	0.500
S3060	S3160	S3260	10.944	12.221	12.359	12.464	6.717	8.370	9.630	11.785	6	2.291	2.291	0.302	1.375	0.500
S3064	S3164	S3264	11.944	13.020	13.201	13.306	6.936	9.101	10.361	12.562	6	2.385	2.385	0.302	1.438	0.500
S3068	S3168	S3268	12.444	13.847	14.034	14.146	7.533	9.777	11.116	13.303	5	2.541	2.541	0.302	1.500	0.500
S3072	S3172	S3272	13.444	14.639	14.829	14.960	7.569	9.852	11.427	14.134	5	2.541	2.541	0.365	1.500	0.500
S3076	S3176	S3276	13.944	15.430	15.623	15.774	7.733	10.056	11.867	14.921	5	2.666	2.666	0.365	1.500	0.500
S3080	S3180	S3280	15.006	16.260	16.430	16.614	8.401	10.449	12.654	15.709	5	2.823	2.885	0.365	1.625	0.500
S3084	S3184	S3284	15.756	17.056	17.298	17.456	8.488	11.402	13.292	16.496	5	2.823	2.948	0.365	1.625	0.500
S3088	S3188	S3288	16.506	17.868	18.094	18.271	9.100	11.817	13.943	17.283	5	3.228	3.228	0.365	1.812	0.500
S3092	S3192	S3292	17.006	18.675	18.928	19.111	9.336	12.368	14.573	18.071	5	3.228	3.323	0.365	1.812	0.500
S3096	S3196	S3296	18.006	19.469	19.741	19.945	9.446	12.714	15.155	18.858	5	3.260	3.354	0.365	1.812	0.500
S30/500	S31/500	S32/500	18.506	20.263	20.581	20.817	9.838	13.657	16.491	19.646	5	3.573	3.666	0.365	1.812	0.500
S30/530	S31/530	S32/530	19.506	21.507	21.793	22.065	10.579	14.004	17.271	20.827	4	3.573	3.666	0.490	1.812	0.500
S30/560	S31/560	S32/560	21.006	22.721	23.000	23.279	11.222	14.569	17.915	22.008	4	3.823	3.916	0.490	1.812	0.500
S30/600	S31/600	S32/600	22.006	24.316	24.644	24.933	11.451	15.388	18.853	23.583	4	3.916	3.916	0.490	1.812	0.500
S30/630	S31/630	S32/630	24.006	25.537	25.875	26.193	11.924	15.979	19.798	24.764	4	3.916	3.916	0.490	2.000	0.500
S30/670	S31/670	S32/670	25.006	27.175	27.522	27.857	12.835	17.008	21.024	26.339	4	4.104	4.104	0.490	2.000	0.625
S30/710	S31/710	S32/710	26.506	28.769	29.127	29.471	13.509	17.801	21.935	27.914	3	4.541	4.635	0.490	2.000	0.625
S30/750	S31/750	S32/750	28.006	30.394	30.771	31.132	14.093	18.620	22.982	29.489	3	4.541	4.635	0.490	2.000	0.625
S30/800	S31/800		29.506	32.389	32.772		14.408	19.014		31.457	3	4.541	4.635	0.490	2.000	0.625
S30/850	S31/850		31.506	34.407	34.827		14.991	20.030		33.426	3	4.573	4.760	0.490	2.000	0.625
S30/900			33.506	36.402			15.681			35.394	3	4.948		0.490	2.000	0.625
S30/950			36.506	38.438			16.492			37.363	3	4.948		0.490	2.000	0.625



ADAPTER SLEEVE SERIES

METRIC ADAPTER SERIES

ADAPTER SERIES H2, H3, H23, H30, H31, H32, H39

Adapter assemblies

Metric Locknut Number

For tapered bore assembly

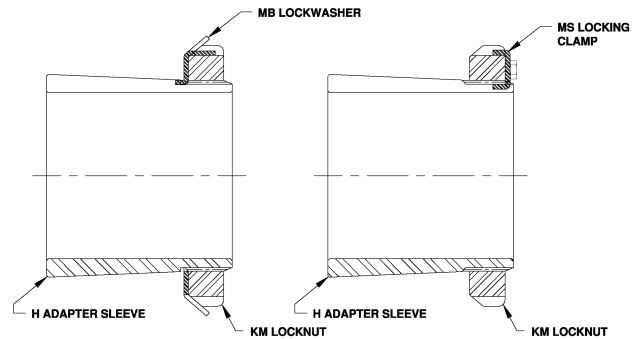

ADAPTER DIMENSIONS

BEARING BORE DIA. (mm)	ADAPTER SERIES					LOCKNUT NO.		BEARING BORE DIA.	ADAPTER SERIES		LOCKNUT NO.	LOCKING DEVICE NO.	BEARING BORE DIA.
	H2	H3	H23	H31	H32	H30	H39						
20	H204	H304	H2304			KM4	MB84	20					20
25	H205	H305	H2305			KM5	MB85	25					25
30	H206	H306	H2306			KM6	MB86	30					30
35	H207	H307	H2307			KM7	MB87	35					35
40	H208	H308	H2308			KM8	MB88	40					40
45	H209	H309	H2309			KM9	MB9	45					45
50	H210	H310	H2310			KM10	MB10	50					50
55	H211	H311	H2311			KM11	MB11	55					55
60	H212	H312	H2312			KM12	MB12	60					60
65	H213	H313	H2313			KM13	MB13	65					65
70	H214	H314	H2314			KM14	MB14	70					70
75	H215	H315	H2315			KM15	MB15	75					75
80	H216	H316	H2316			KM16	MB16	80					80
85	H217	H317	H2317			KM17	MB17	85					85
90	H218	H318	H2318			KM18	MB18	90					90
95	H219	H319	H2319			KM19	MB19	95					95
100	H220	H320	H2320	H3120		KM20	MB20	100					100
105	H221	H321	H2321			KM21	MB21	105					105
110	H222	H322	H2322	H3122		KM22	MB22	110					110
120			H2324	H3124		KM24	MB24	120	H3024	H3924	KML24	MBL24	120
130			H2326	H3126		KM26	MB26	130	H3026	H3926	KML26	MBL26	130
140			H2328	H3128		KM28	MB28	140	H3028	H3928	KML28	MBL28	140
150			H2330	H3130		KM30	MB30	150	H3030	H3930	KML30	MBL30	150
160			H2332	H3132		KM32	MB32	160	H3032	H3932	KML32	MBL32	160
170			H2334	H3134		KM34	MB34	170	H3034	H3934	KML34	MBL34	170
180			H2336	H3136		KM36	MB36	180	H3036	H3936	KML36	MBL36	180
190			H2338	H3138		KM38	MB38	190	H3038	H3938	KML38	MBL38	190
200			H2340	H3140		KM40	MB40	200	H3040	H3940	KML40	MBL40	200
220			H2344	H3144		HM44T	MB44	220	H3044	H3944	HM3044	MS3044	220
240			H2348	H3148		HM48T	MB48	240	H3048	H3948	HM3048	MS3048	240
260			H2352	H3152		HM52T	MB52	260	H3052	H3952	HM3052	MS3052	260
280			H2356	H3156		HM56T	MB56	280	H3056	H3956	HM3056	MS3056	280
300				H3160	H3260	HM3160	MS3160	300	H3060	H3960	HM3060	MS3060	300
320				H3164	H3264	HM3164	MS3164	320	H3064	H3964	HM3064	MS3064	320
340				H3168	H3268	HM3168	MS3168	340	H3068	H3968	HM3068	MS3068	340
360				H3172	H3272	HM3172	MS3172	360	H3072	H3972	HM3072	MS3072	360
380				H3176	H3276	HM3176	MS3176	380	H3076	H3976	HM3076	MS3076	380
400				H3180	H3280	HM3180	MS3180	400	H3080	H3980	HM3080	MS3080	400
420				H3184	H3284	HM3184	MS3184	420	H3084	H3984	HM3084	MS3084	420
440				H3188	H3288	HM3188	MS3188	440	H3088	H3988	HM3088	MS3088	440
460				H3192	H3292	HM3192	MS3192	460	H3092	H3992	HM3092	MS3092	460
480				H3196	H3296	HM3196	MS3196	480	H3096	H3996	HM3096	MS3096	480
500				H31500	H32500	HM31500	MS31500	500	H30500	H39500	HM30500	MS30500	500

METRIC ADAPTER SERIES



METRIC SLEEVE SERIES

ADAPTER SERIES H2, H3

For tapered bore assembly

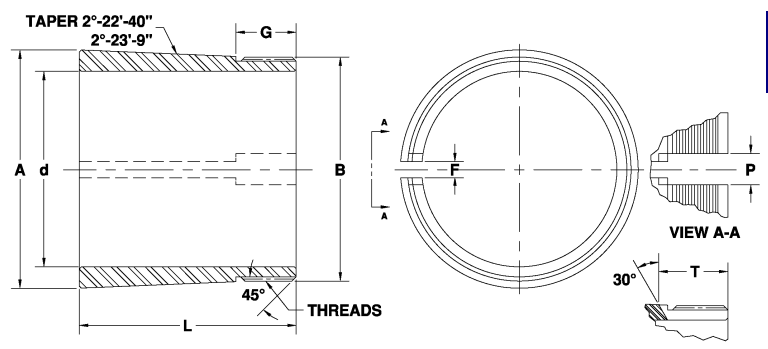

SERIES H2 METRIC ADAPTER SLEEVE DIMENSIONS

SLEEVE NO.	BORE DIA. d NOM.	SHARP CORNER DIA. A MIN.	SLEEVE LENGTH L MAX.	THREADS		WIDTH F MIN.	SLOT WIDTH P MIN.	DEPTH T MIN.
				METRIC THREADS	THD. LENGTH G MIN.			
H204	0.669	0.843	0.945	M20 X 1	0.433	0.059	0.197	0.512
H205	0.787	1.043	1.024	M25 X 1.5	0.512	0.079	0.236	0.630
H206	0.984	1.240	1.063	M30 X 1.5	0.512	0.079	0.236	0.630
H207	1.181	1.441	1.142	M35 X 1.5	0.551	0.079	0.276	0.669
H208	1.378	1.642	1.220	M40 X 1.5	0.591	0.079	0.276	0.709
H209	1.575	1.843	1.299	M45 X 1.5	0.630	0.079	0.276	0.748
H210	1.772	2.043	1.378	M50 X 1.5	0.669	0.079	0.276	0.787
H211	1.968	2.244	1.457	M55 X 2	0.709	0.098	0.354	0.827
H212	2.165	2.445	1.496	M60 X 2	0.709	0.098	0.354	0.827
H213	2.362	2.646	1.575	M65 X 2	0.748	0.098	0.354	0.866
H214	2.362	2.846	1.614	M70 X 2	0.787	0.098	0.354	0.945
H215	2.559	3.047	1.693	M75 X 2	0.827	0.118	0.354	0.984
H216	2.756	3.244	1.811	M80 X 2	0.906	0.118	0.433	1.063
H217	2.953	3.453	1.968	M85 X 2	0.984	0.118	0.433	1.142
H218	3.150	3.654	2.047	M90 X 2	0.984	0.118	0.433	1.142
H219	3.346	3.858	2.165	M95 X 2	1.024	0.118	0.433	1.181
H220	3.543	4.063	2.283	M100 X 2	1.063	0.118	0.512	1.220
H221	3.740	4.264	2.362	M105 X 2	1.063	0.118	0.512	1.220
H222	3.937	4.468	2.480	M110 X 2	1.102	0.118	0.512	1.260

SERIES H3 METRIC ADAPTER SLEEVE DIMENSIONS

SLEEVE NO.	BORE DIA. d NOM.	SHARP CORNER DIA. A MIN.	SLEEVE LENGTH L MAX.	THREADS		WIDTH F MIN.	SLOT WIDTH P MIN.	DEPTH T MIN.
				METRIC THREADS	THD. LENGTH G MIN.			
H304	0.669	0.858	1.102	M20 X 1	0.433	0.059	0.197	0.512
H305	0.787	1.051	1.142	M25 X 1.5	0.512	0.079	0.236	0.630
H306	0.984	1.256	1.220	M30 X 1.5	0.512	0.079	0.236	0.630
H307	1.181	1.461	1.378	M35 X 1.5	0.551	0.079	0.276	0.669
H308	1.378	1.657	1.417	M40 X 1.5	0.591	0.079	0.276	0.709
H309	1.575	1.862	1.535	M45 X 1.5	0.630	0.079	0.276	0.748
H310	1.772	2.067	1.654	M50 X 1.5	0.669	0.079	0.276	0.787
H311	1.968	2.272	1.772	M55 X 2	0.709	0.098	0.354	0.827
H312	2.165	2.476	1.850	M60 X 2	0.709	0.098	0.354	0.827
H313	2.362	2.677	1.968	M65 X 2	0.748	0.098	0.354	0.866
H314	2.362	2.882	2.047	M70 X 2	0.787	0.098	0.354	0.945
H315	2.559	3.087	2.165	M75 X 2	0.827	0.118	0.354	0.984
H316	2.756	3.287	2.323	M80 X 2	0.906	0.118	0.433	1.063
H317	2.953	3.496	2.480	M85 X 2	0.984	0.118	0.433	1.142
H318	3.150	3.697	2.559	M90 X 2	0.984	0.118	0.433	1.142
H319	3.346	3.902	2.677	M95 X 2	1.024	0.118	0.433	1.181
H320	3.543	4.102	2.795	M100 X 2	1.063	0.118	0.512	1.220
H321	3.740	4.311	2.913	M105 X 2	1.063	0.118	0.512	1.220
H322	3.937	4.516	3.031	M110 X 2	1.102	0.118	0.512	1.260



METRIC SLEEVE SERIES

METRIC SLEEVE SERIES

ADAPTER SERIES H30

For tapered bore assembly

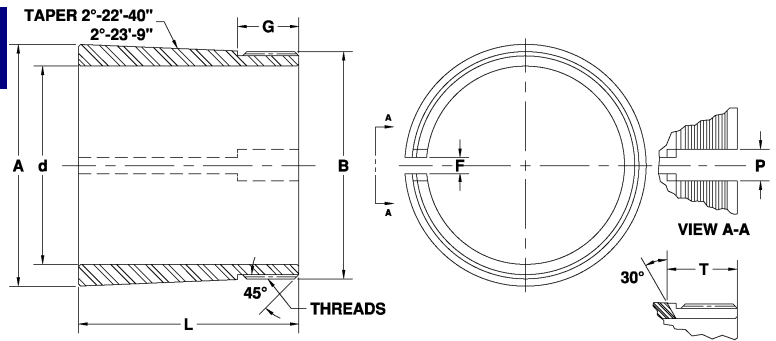

SERIES H30 METRIC ADAPTER SLEEVE DIMENSIONS

SLEEVE NO.	BORE DIA. d NOM.	SHARP CORNER DIA. A MIN.	SLEEVE LENGTH L MAX.	THREADS		WIDTH F MIN.	SLOT WIDTH P MIN.	DEPTH T MIN.
				METRIC THREADS	THD. LENGTH G MIN.			
H3024	4.331	4.890	2.835	M120 X 2	1.142	0.197	0.591	1.339
H3026	4.528	5.307	3.150	M130 X 2	1.220	0.197	0.591	1.417
H3028	4.921	5.701	3.228	M140 X 2	1.260	0.197	0.669	1.457
H3030	5.315	6.106	3.425	M150 X 2	1.339	0.197	0.669	1.535
H3032	5.512	6.516	3.661	M160 X 3	1.417	0.236	0.748	1.654
H3034	5.906	6.929	3.976	M170 X 3	1.457	0.236	0.748	1.693
H3036	6.299	7.346	4.291	M180 X 3	1.496	0.236	0.827	1.732
H3038	6.693	7.748	4.409	M190 X 3	1.575	0.236	0.827	1.811
H3040	7.087	8.165	4.724	M200 X 3	1.614	0.236	0.827	1.850
H3044	7.874	8.976	4.961	TR220 X 4	1.535	0.197	0.787	0.827
H3048	8.661	9.772	5.236	TR240 X 4	1.693	0.315	0.787	0.827
H3052	9.449	10.598	5.709	TR260 X 4	1.732	0.315	0.787	0.866
H3056	10.236	11.398	5.984	TR280 X 4	1.890	0.315	0.945	0.866
H3060	11.024	12.224	6.614	TR300 X 4	2.047	0.315	0.945	0.866
H3064	11.811	13.024	6.732	TR320 X 5	2.037	0.315	0.945	0.984
H3068	12.598	13.850	7.362	TR340 X 5	2.205	0.315	0.945	1.024
H3072	13.386	14.642	7.402	TR360 X 5	2.205	0.394	1.102	1.024
H3076	14.173	15.437	7.598	TR380 X 5	2.362	0.394	1.102	1.024
H3080	14.961	16.268	8.268	TR400 X 5	2.520	0.394	1.102	1.063
H3084	15.478	17.059	8.346	TR420 X 5	2.520	0.394	1.260	1.063
H3088	16.142	17.874	8.976	TR440 X 5	2.874	0.394	1.260	1.063
H3092	16.929	18.681	9.213	TR460 X 5	2.874	0.394	1.260	1.102
H3096	17.717	19.480	9.331	TR480 X 5	2.874	0.394	1.417	1.102
H30/500	18.504	20.272	9.724	TR500 X 5	3.189	0.394	1.417	1.102

METRIC SLEEVE SERIES



METRIC SLEEVE SERIES

ADAPTER SERIES H31, H32

For tapered bore assembly

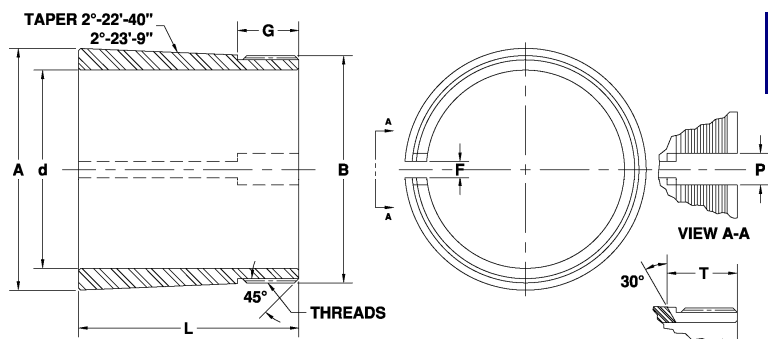

SERIES H31 and H32 METRIC ADAPTER SLEEVE DIMENSIONS

SLEEVE NO.	BORE DIA. d NOM.	SHARP CORNER DIA. A MIN.	SLEEVE LENGTH L MAX.	THREADS METRIC THREADS	THREADS		WIDTH F MIN.	SLOT WIDTH P MIN.	DEPTH T MIN.
					THD. LENGTH G MIN.				
H3120	3.543	4.122	2.992	M100 X 2	1.063		0.118	0.512	1.220
H3122	3.937	4.528	3.189	M110 X 2	1.102		0.118	0.512	1.260
H3124	4.331	4.941	3.465	M120 X 2	1.142		0.197	0.591	1.339
H3126	4.528	5.346	3.622	M130 X 2	1.220		0.197	0.591	1.417
H3128	4.921	5.752	3.819	M140 X 2	1.260		0.197	0.669	1.457
H3130	5.315	6.185	4.370	M150 X 2	1.339		0.197	0.669	1.535
H3132	5.512	6.598	4.685	M160 X 3	1.417		0.236	0.748	1.654
H3134	5.906	7.000	4.803	M170 X 3	1.457		0.236	0.748	1.693
H3136	6.299	7.421	5.157	M180 X 3	1.496		0.236	0.827	1.732
H3138	6.693	7.843	5.551	M190 X 3	1.575		0.236	0.827	1.811
H3140	7.087	8.264	5.906	M200 X 3	1.614		0.236	0.827	1.850
H3144	7.874	9.075	6.339	TR220 X 4	1.732		0.236	0.984	2.008
H3148	8.661	9.890	6.772	TR240 X 4	1.811		0.236	0.984	2.087
H3152	9.449	10.732	7.480	TR260 X 4	1.929		0.315	1.142	2.205
H3156	10.236	11.528	7.677	TR280 X 4	2.008		0.315	1.142	2.283
H3160	11.024	12.362	8.189	TR300 X 4	1.968		0.315	0.945	0.866
H3164	11.811	13.201	8.898	TR320 X 5	2.087		0.315	0.945	0.984
H3168	12.598	14.039	10.000	TR340 X 5	2.598		0.315	1.102	1.024
H3172	13.386	14.831	10.197	TR360 X 5	2.717		0.394	1.102	1.024
H3176	14.173	15.630	10.394	TR380 X 5	2.835		0.394	1.260	1.024
H3180	14.961	16.437	10.709	TR400 X 5	2.913		0.394	1.260	1.063
H3184	15.748	17.303	11.968	TR420 X 5	3.228		0.394	1.260	1.063
H3188	16.142	18.098	12.087	TR440 X 5	3.268		0.394	1.417	1.063
H3192	16.929	19.287	12.835	TR460 X 5	3.465		0.394	1.417	1.102
H3196	17.717	19.752	13.189	TR480 X 5	3.465		0.394	1.417	1.102
H31/500	18.504	20.591	14.016	TR500 X 5	3.661		0.394	1.575	1.102
H3260	11.024	12.469	9.449	TR300 X 4	1.968		0.315	0.945	0.866
H3264	11.811	13.307	10.157	TR320 X 5	2.087		0.315	0.945	0.984
H3268	12.598	14.150	11.339	TR340 X 5	2.598		0.315	1.102	1.024
H3272	13.386	14.965	11.772	TR360 X 5	2.717		0.394	1.102	1.024
H3276	14.173	15.780	12.205	TR380 X 5	2.835		0.394	1.260	1.024
H3280	14.961	16.622	12.913	TR400 X 5	2.913		0.394	1.260	1.063
H3284	15.748	17.461	13.858	TR420 X 5	3.228		0.394	1.260	1.063
H3288	16.142	18.280	14.213	TR440 X 5	3.268		0.394	1.417	1.063
H3292	16.929	19.118	15.039	TR460 X 5	3.465		0.394	1.417	1.102
H3296	17.717	19.953	15.630	TR480 X 5	3.465		0.394	1.417	1.102
H32/500	18.504	20.472	16.850	TR500 X 5	3.661		0.394	1.575	1.102



METRIC SLEEVE SERIES

METRIC SLEEVE SERIES

ADAPTER SERIES H23, H39

For tapered bore assembly

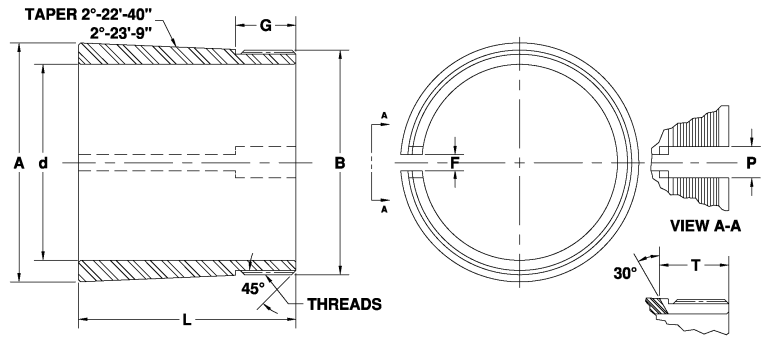

SERIES H23 METRIC ADAPTER SLEEVE DIMENSIONS

SLEEVE NO.	BORE DIA. d NOM.	SHARP CORNER DIA. A MIN.	SLEEVE LENGTH L MAX.	THREADS		WIDTH F MIN.	SLOT WIDTH P MIN.	DEPTH T MIN.
				METRIC THREADS	THD. LENGTH G MIN.			
H2304	0.669	0.866	1.220	M20 X 1	0.433	0.059	0.197	0.512
H2305	0.787	1.071	1.378	M25 X 1.5	0.512	0.079	0.236	0.630
H2306	0.984	1.280	1.496	M30 X 1.5	0.512	0.079	0.236	0.630
H2307	1.181	1.488	1.693	M35 X 1.5	0.551	0.079	0.276	0.669
H2308	1.378	1.693	1.811	M40 X 1.5	0.591	0.079	0.276	0.709
H2309	1.575	1.898	1.968	M45 X 1.5	0.630	0.079	0.276	0.748
H2310	1.772	2.106	2.165	M50 X 1.5	0.669	0.079	0.276	0.787
H2311	1.968	2.319	2.323	M55 X 2	0.709	0.098	0.354	0.827
H2312	2.165	2.524	2.441	M60 X 2	0.709	0.098	0.354	0.827
H2313	2.362	2.728	2.559	M65 X 2	0.748	0.098	0.354	0.866
H2314	2.362	2.933	2.677	M70 X 2	0.787	0.098	0.354	0.945
H2315	2.559	3.146	2.874	M75 X 2	0.827	0.118	0.354	0.984
H2316	2.756	3.350	3.071	M80 X 2	0.906	0.118	0.433	1.063
H2317	2.953	3.555	3.228	M85 X 2	0.984	0.118	0.433	1.142
H2318	3.150	3.768	3.386	M90 X 2	0.984	0.118	0.433	1.142
H2319	3.346	3.972	3.543	M95 X 2	1.024	0.118	0.433	1.181
H2320	3.543	4.189	3.819	M100 X 2	1.063	0.118	0.512	1.220
H2321	3.740	4.402	3.976	M105 X 2	1.063	0.118	0.512	1.220
H2322	3.937	4.606	4.134	M110 X 2	1.102	0.118	0.512	1.260
H2324	4.331	5.020	4.409	M120 X 2	1.142	0.197	0.591	1.339
H2326	4.528	5.441	4.764	M130 X 2	1.220	0.197	0.591	1.417
H2328	4.921	5.862	5.157	M140 X 2	1.260	0.197	0.669	1.457
H2330	5.315	6.276	5.472	M150 X 2	1.339	0.197	0.669	1.535
H2332	5.512	6.693	5.787	M160 X 3	1.417	0.236	0.748	1.654
H2334	5.906	7.106	6.063	M170 X 3	1.457	0.236	0.748	1.693
H2336	6.299	7.520	6.339	M180 X 3	1.496	0.236	0.827	1.732
H2338	6.693	7.933	6.654	M190 X 3	1.575	0.236	0.827	1.811
H2340	7.087	8.346	6.929	M200 X 3	1.614	0.236	0.827	1.850
H2344	7.874	9.157	7.323	TR220 X 4	1.732	0.236	0.984	2.008
H2348	8.661	9.980	7.835	TR240 X 4	1.811	0.236	0.984	2.087
H2352	9.449	10.799	8.307	TR260 X 4	1.929	0.315	1.142	2.205
H2356	10.236	11.626	8.819	TR280 X 4	2.008	0.315	1.142	2.283

SERIES H39 METRIC ADAPTER SLEEVE DIMENSIONS

SLEEVE NO.	BORE DIA. d NOM.	SHARP CORNER DIA. A MIN.	SLEEVE LENGTH L MAX.	THREADS		WIDTH F MIN.	SLOT WIDTH P MIN.	DEPTH T MIN.
				METRIC THREADS	THD. LENGTH G MIN.			
H3924	4.331	4.850	2.362	M120 X 2	1.142	0.197	0.591	1.339
H3926	4.528	5.256	2.559	M130 X 2	1.220	0.197	0.591	1.417
H3928	4.921	5.650	2.598	M140 X 2	1.260	0.197	0.669	1.457
H3930	5.315	6.071	2.992	M150 X 2	1.339	0.197	0.669	1.535
H3932	5.512	6.465	3.071	M160 X 3	1.417	0.236	0.748	1.654
H3934	5.906	6.858	3.110	M170 X 3	1.457	0.236	0.748	1.693
H3936	6.299	7.276	3.425	M180 X 3	1.496	0.236	0.827	1.732
H3938	6.693	7.673	3.504	M190 X 3	1.575	0.236	0.827	1.811
H3940	7.087	8.091	3.858	M200 X 3	1.614	0.236	0.827	1.850
H3944	7.874	8.878	3.780	TR220 X 4	1.535	0.197	0.787	0.827
H3948	8.661	9.669	3.976	TR240 X 4	1.693	0.315	0.787	0.827
H3952	9.449	10.504	4.567	TR260 X 4	1.732	0.315	0.787	0.866
H3956	10.236	11.295	4.764	TR280 X 4	1.890	0.315	0.945	0.866
H3960	11.024	12.134	5.515	TR300 X 4	2.047	0.315	0.945	0.866
H3964	11.811	12.921	5.512	TR320 X 5	2.087	0.315	0.945	0.984
H3968	12.598	13.709	5.669	TR340 X 5	2.205	0.315	0.945	1.024
H3972	13.386	14.496	5.669	TR360 X 5	2.205	0.394	1.102	1.024
H3976	14.173	15.343	6.457	TR380 X 5	2.362	0.394	1.102	1.024
H3980	14.960	16.130	6.614	TR400 X 5	2.520	0.394	1.102	1.063
H3984	15.748	16.917	6.614	TR420 X 5	2.520	0.394	1.260	1.063
H3988	16.142	17.744	7.441	TR440 X 5	2.874	0.394	1.260	1.063
H3992	16.929	18.531	7.441	TR460 X 5	2.874	0.394	1.260	1.102
H3996	17.717	19.358	7.874	TR480 X 5	2.874	0.394	1.417	1.102
H39/500	18.504	20.146	8.189	TR500 X 5	3.189	0.394	1.417	1.102

METRIC SLEEVE SERIES





Withdrawal Sleeves Bearing Accessories



SK & ASK SERIES

WITHDRAWAL SLEEVE DIMENSIONS

Inch design and corresponding
Removal nut or locknut

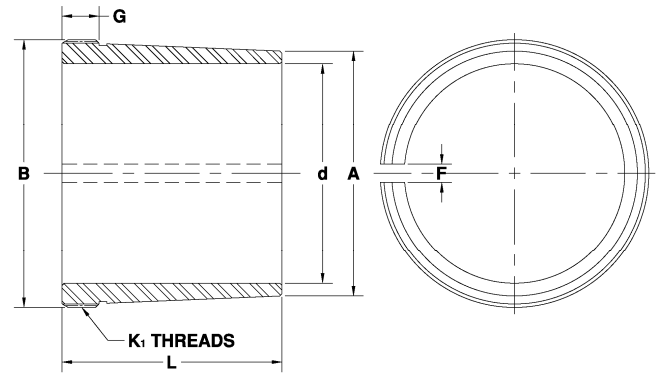

WITHDRAWAL SLEEVE DIMENSIONS

WITHDRAWAL SLEEVE				BEARING	SLEEVE BORE	SLEEVE SHARP		LENGTH		THREADS			SLOT	LOCKNUT	LOCKWAS	REMOVAL	
NO.	APP. WT. (LB.)			BORE DIA.	BORE DIA.	CORNER DIA.				NO. PER INCH	MAJOR DIA.	THD. LGTH.	WIDTH		HER	NUT	
-00	-000	-00	-000	d	d	A	A	L	L	K ₁	B	G	F				
				MAX.	MAX.	REF.	REF.	MAX.	MAX.		MAX.	NOM.	MIN.				
SK-8	SK-108	0.16	0.25	1.5748	1.3792	1.585	1.585	1.181	1.575	18	1.767	0.236	0.276	0.052	N07	W07	N09
SK-9	SK-109	0.22	0.31	1.7717	1.576	1.781	1.782	1.26	1.732	18	1.967	0.236	0.276	0.052	N08	W08	N10
SK-10	SK-110	0.25	0.47	1.9685	1.7729	1.978	1.978	1.378	1.968	18	2.204	0.276	0.315	0.052	N09	W09	RN10
SK-11	SK-111	0.31	0.56	2.1654	1.9697	2.175	2.175	1.457	2.126	18	2.407	0.276	0.354	0.052	N10	W10	RN11
SK-12	SK-112	0.41	0.69	2.3622	2.1669	2.372	2.372	1.575	2.244	18	2.626	0.295	0.394	0.052	N11	W11	RN12
ASK-13	ASK-113	0.50	0.84	2.5591	2.3637	2.569	2.569	1.654	2.402	12	2.933	0.295	0.433	0.084	N12	W12	AN15
ASK-14	ASK-114	0.94	1.55	2.7559	2.3637	2.769	2.769	1.732	2.559	12	3.137	0.295	0.472	0.084	N12	W12	AN16
ASK-15	ASK-115	1.25	1.80	2.9528	2.5605	2.966	2.966	1.85	2.717	12	3.34	0.315	0.472	0.084	N13	W13	AN17
ASK-16	ASK-116	1.25	2.00	3.1496	2.7574	3.163	3.163	1.969	2.835	12	3.527	0.354	0.472	0.084	N14	W14	AN18
ASK-17	ASK-117	1.45	2.25	3.3465	2.9543	3.359	3.359	2.047	2.953	12	3.73	0.354	0.512	0.084	AN15	W15	AN19
ASK-18	ASK-118	1.55	2.55	3.5433	3.1511	3.556	3.556	2.087	3.15	12	3.918	0.354	0.551	0.084	AN16	W16	AN20
ASK-19	ASK-119	1.80	2.95	3.7402	3.3482	3.753	3.753	2.244	3.346	12	4.122	0.399	0.591	0.084	AN17	W17	AN21
ASK-20	ASK-120	2.00	3.40	3.937	3.545	3.95	3.95	2.323	3.543	12	4.325	0.413	0.591	0.115	AN18	W18	AN22
ASK-22	ASK-122	2.45	4.25	4.3307	3.9387	4.344	4.344	2.559	3.858	12	4.778	0.433	0.63	0.115	AN20	W20	ARN22
ASK-24	ASK-124	3.15	5.00	4.7244	4.3324	4.737	4.738	2.835	4.134	12	5.185	0.472	0.669	0.115	AN22	W22	ARN24
ASK-26	ASK-126	5.00	8.00	5.1181	4.5293	5.131	5.131	3.071	4.528	12	5.622	0.472	0.748	0.115	AN22	W22	ARN26
SK-28	SK-128	5.90	9.50	5.5118	4.9233	5.528	5.528	3.228	4.921	8	6.097	0.512	0.787	0.115	AN24	W24	RN28
SK-30	SK-130	6.80	11.50	5.9055	5.317	5.922	5.922	3.465	5.315	8	6.503	0.551	0.945	0.115	AN26	W26	RN30
SK-32	SK-132	9.95	15.30	6.2992	5.5138	6.316	6.319	3.78	5.512	8	6.925	0.551	0.945	0.178	AN28	W28	RN32
SK-34	SK-134	11.50	17.50	6.6929	5.9075	6.704	6.713	4.094	5.748	8	7.331	0.63	0.945	0.178	AN30	W30	RN34
SK-36	SK-136	12.50	20.50	7.0866	6.3012	7.103	7.106	4.094	6.063	8	7.753	0.63	1.024	0.178	AN32	W32	RN36
SK-38	SK-138	14.50	22.00	7.4803	6.6949	7.497	7.503	4.409	6.299	8	8.191	0.709	1.024	0.178	AN34	W34	RN38
SK-40	SK-140	16.50	25.50	7.874	7.0886	7.89	7.897	4.646	6.693	8	8.628	0.709	1.181	0.178	AN36	W36	N44
SK-44	SK-144	19.50	29.50	8.6614	7.8762	8.681	8.688	5.118	7.126	6	9.442	0.709	1.181	0.178	AN40	W40	N048
SK-48	SK-148	24.50	34.00	9.4488	8.6636	9.469	9.475	5.669	7.441	6	10.192	0.787	1.181	0.178	N44	W44	N052
SK-52	SK-152	30.90	40.75	10.2362	9.451	10.256	10.262	6.102	7.874	6	11.004	0.787	1.181	0.178	N048	P48	N056
SK-56	SK-156	33.10	48.50	11.0236	10.2388	11.05	11.05	6.102	8.268	6	11.973	0.787	1.181	0.302	N052	P52	RN56
SK-60		39.20		11.811	11.0262	11.837		6.693		6	12.942	0.984		0.302	N056	P56	RN60
SK-64		46.30		12.5981	11.8136	12.631		7.087		6	13.723	0.984		0.302	N060	P60	RN64



WITHDRAWAL SLEEVES

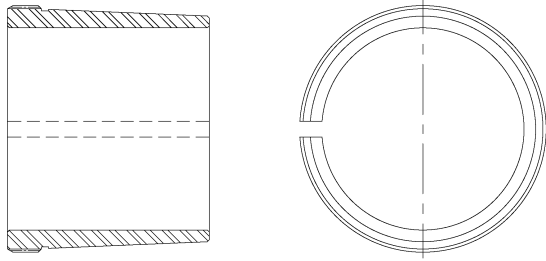

AH SERIES

METRIC WITHDRAWAL SLEEVES

Metric Design and corresponding
Removal nut or locknut

WITHDRAWAL SLEEVE DIMENSIONS

BEARING SHAFT		AH2		AH3		AH23		AH31		AH32		AH30		AH22		AH39	
BORE DIA.	DIA.	SLEEVE NO.	REMOVAL NUT	SLEEVE NO.	REMOVAL NUT	SLEEVE NO.	REMOVAL NUT	SLEEVE NO.	REMOVAL NUT	SLEEVE NO.	REMOVAL NUT	SLEEVE NO.	REMOVAL NUT	SLEEVE NO.	REMOVAL NUT	SLEEVE NO.	REMOVAL NUT
40	35	AH208	KM9	AH308	KM9	AH2308	KM9										
45	40	AH209	KM10	AH309	KM10	AH2309	KM10										
50	45	AH210	KM11	AH310	KM11	AH2310	KM11										
55	50	AH211	KM12	AH311	KM12	AH2311	KM12										
60	55	AH212	KM13	AH312	KM13	AH2312	KM13										
65	60	AH213	KM15	AH313	KM15	AH2313	KM15										
70	65	AH214	KM16	AH314	KM16	AH2314	KM16										
75	70	AH215	KM17	AH315	KM17	AH2315	KM17										
80	75	AH216	KM18	AH316	KM18	AH2316	KM18										
85	80	AH217	KM19	AH317	KM19	AH2317	KM19										
90	85	AH218	KM20	AH318	KM20	AH2318	KM20			AH3218	KM20						
95	90	AH219	KM21	AH319	KM21	AH2319	KM21			AH3219	KM21						
100	95	AH220	KM22	AH320	KM22	AH2320	KM22	AH3120	KM22	AH3220	KM22						
110	105	AH222	KM24	AH322	KM24	AH2322	KM25	AH3122	KM24	AH3222	KM25						
120	115	AH224	KM26	AH324	KM26	AH2324	KM27	AH3124	KM26	AH3224	KM27	AH3024	KM26				
130	125	AH226	KM28	AH326	KM28	AH2326	KM29	AH3126	KM28	AH3226	KM29	AH3026	KM28				
140	135	AH228	KM30	AH328	KM30	AH2328	KM31	AH3128	KM30	AH3228	KM31	AH3028	KM30				
150	145	AH230	KM32	AH330	KM33	AH2330	KM33	AH3130	KM33	AH3230	KM33	AH3030	KM32				
160	150	AH232	KM34	AH332	KM36	AH232	KM36	AH3132	KM36	AH3232	KM36	AH3032	KM34				
170	160	AH234	KM36	AH334	KM38	AH2334	KM39	AH3134	KM38	AH3234	KM38	AH3034	KM36			AH3934	HMLL36
180	170	AH236	KM38			AH2336	KM40	AH3136	KM40	AH3236	KM40	AH3036	KM38	AH2236	KM40	AH3936	HMLL38
190	180	AH238	HML41T			AH2338	HM42T	AH3138	HM42T	AH3238	HM42T	AH3038	HML41T	AH2238	HM42T	AH3938	HMLL40
200	190	AH240	HML43T			AH2340	HM44T	AH3140	HM44T	AH3240	HM44T	AH3040	HML43T	AH2240	HM44T	AH3940	HMLL42T
220	200	AH244	HML47T			AH2344	HM48T	AH3144	HM48T			AH3044	HML47T	AH2244	HM48T	AH3944	HMLL46T
240	220	AH248	HML52T			AH2348	HM52T	AH3148	HM52T			AH3048	HML52T	AH2248	HM52T	AH3948	HMLL50T
260	240	AH252	HML56T			AH2352	HM58T	AH3152	HM58T			AH3052	HML56T	AH2252	HM58T	AH3952	HML55T
280	260	AH256	HML60T			AH2356	HM62T	AH3156	HM62T			AH3056	HML60T	AH2256	HM62T	AH3956	HML59T
300	280							AH3160	HM66T	AH3260	HM66T	AH3060	HML64T	AH2260	HM66T	AH3960	HML63T
320	300							AH3164	HM70T	AH3264	HM70T	AH3064	HML69T	AH2264	HM70T	AH3964	HML67T
340	320							AH3168	HM74T	AH3268	HM74T	AH3068	HML73T			AH3968	HML71T
360	340							AH3172	HM80T	AH3272	HM80T	AH3072	HML77T			AH3972	HMLL75T
380	360							AH3176	HM84T	AH3276	HM84T	AH3076	HML82T			AH3976	HMLL79T
400	380							AH3180	HM88T	AH3280	HM88T	AH3080	HML86T			AH3980	HMLL83T
420	400							AH3184	HM92T	AH3284	HM92T	AH3084	HML90T			AH3984	HMLL87T
440	420							AH3188	HM96T	AH3288	HM96T	AH3088	HML94T			AH3988	HMLL92T
460	440							AH3192	HM102T	AH3292	HM102T	AH3092	HML98T			AH3992	HMLL96T
480	460							AH3196	HM106T	AH3296	HM106T	AH3096	HML104T			AH3996	HMLL100T
500	480							AH31500	HM110T	AH32500	HM110T	AH30500	HML108T			AH39500	HMLL104T

WITHDRAWAL SLEEVES





Removal Nuts

Bearing Accessories



RN REMOVAL NUT SERIES

RN AND ARN SERIES

Inch design/Ball, cylindrical, spherical and tapered roller bearings

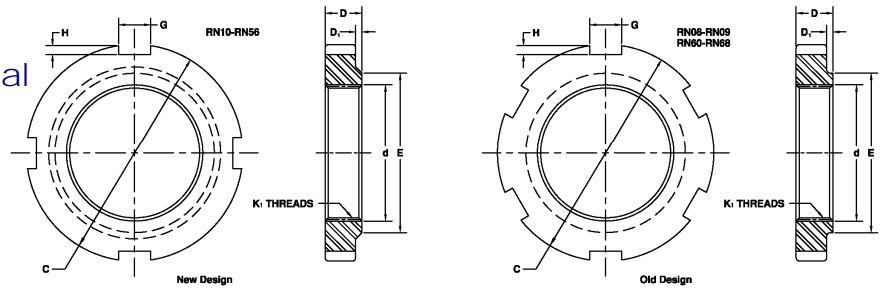

REMOVAL NUT DIMENSIONS

LOCKNUT NO.	MAJOR DIA. d	THREADS NO. PER INCH K ₁	OUTSIDE DIA. C MAX.	FACE DIA. E MAX.	NUT WIDTH D MAX.	SLOT		CHAMFER DEPTH D ₁ MAX.
						WIDTH G MIN.	DEPTH H MAX.	
RN08	1.767	18	2.827	2.072	0.385	0.490	0.151	0.070
RN09	1.967	18	2.984	2.291	0.448	0.490	0.151	0.070
RN10	2.204	18	3.062	2.562	0.594	0.240	0.135	0.078
RN11	2.407	18	3.281	2.812	0.594	0.240	0.135	0.078
RN12	2.626	18	3.500	3.062	0.656	0.240	0.135	0.078
ARN22	4.778	12	6.312	5.375	0.781	0.610	0.260	0.141
ARN24	5.185	12	6.938	5.625	0.844	0.610	0.291	0.141
ARN26	5.622	12	7.312	6.062	0.906	0.610	0.291	0.141
RN28	6.097	8	7.938	6.563	0.969	0.610	0.291	0.141
RN30	6.503	8	8.312	7.062	1.031	0.735	0.323	0.141
RN32	6.925	8	8.938	7.562	1.031	0.735	0.323	0.141
RN34	7.331	8	9.312	8.062	1.094	0.860	0.385	0.141
RN36	7.753	8	9.875	8.563	1.094	0.860	0.385	0.141
RN38	8.191	8	10.688	9.125	1.156	0.860	0.385	0.141
RN56	11.973	6	15.188	13.562	1.468	1.230	0.510	0.203
RN60	12.942	6	16.397	13.635	1.676	3.510	0.698	0.200
RN64	13.723	6	17.015	15.010	1.760	3.510	0.698	0.200
RN68	14.345	5-ACME	17.515	15.760	1.760	3.885	0.760	0.200
RN72	14.957	5-ACME	18.515	16.135	1.760	3.885	0.760	0.200
RN76	15.988	5-ACME	19.640	17.635	1.760	3.885	0.760	0.200
RN80	17.319	5-ACME	21.140	18.010	1.885	3.885	0.760	0.260
RN84	18.107	5-ACME	22.390	18.760	2.010	4.010	0.885	0.260
RN88	18.894	5-ACME	23.640	19.635	2.135	4.010	0.885	0.260
RN92	19.682	5-ACME	25.140	20.510	2.260	4.010	0.885	0.260
RN96	20.867	4-ACME	26.390	21.260	2.385	4.010	0.885	0.260

Notes:

Metric HM-T, HML-T, and HMLL-T Series Removal Nuts are also available

REMOVAL NUT SERIES





Locknuts

Bearing Accessories



N-00 SERIES

LOCKNUT DIMENSIONS

Inch dimensions for ball, roller, spherical and tapered roller bearings

Standard Locknut Series

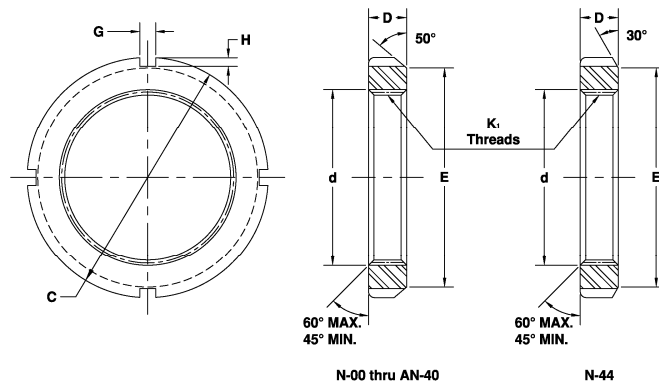

LOCKNUT DIMENSIONS

LOCKNUT NO.	THREADS		OUTSIDE		FACE		NUT		SLOT		FACE		APP. WT. (LB./C)
	MAJOR DIA. d	NO. PER INCH K ₁	DIA. C	DIA. E	DIA. D	WIDTH D	WIDTH G	DEPTH H	RUNOUT S _d				
	MIN.		MAX.	MAX.	MAX.	MAX.	MAX.	MAX.	MAX.	MAX.	MAX.		
N-00	0.391	32	0.755	0.625	0.229	0.120	0.073	0.002	2.0				
N-01	0.469	32	0.880	0.719	0.323	0.120	0.073	0.002	3.3				
N-02	0.586	32	1.005	0.813	0.323	0.120	0.104	0.002	3.5				
N-03	0.664	32	1.130	0.938	0.354	0.120	0.104	0.002	5.3				
N-04	0.781	32	1.380	1.125	0.385	0.178	0.104	0.002	9.0				
N-05	0.969	32	1.568	1.281	0.416	0.178	0.104	0.002	11.5				
N-06	1.173	18	1.755	1.500	0.416	0.178	0.104	0.002	13.0				
N-07	1.376	18	2.068	1.813	0.448	0.178	0.104	0.004	21.0				
N-08	1.563	18	2.255	2.000	0.448	0.240	0.104	0.004	22.5				
N-09	1.767	18	2.536	2.281	0.448	0.240	0.104	0.004	29.0				
N-10	1.967	18	2.693	2.438	0.510	0.240	0.104	0.004	34.0				
N-11	2.175	18	2.974	2.656	0.510	0.240	0.135	0.004	42.0				
N-12	2.360	18	3.161	2.844	0.541	0.240	0.135	0.004	47.0				
N-13	2.548	18	3.380	3.063	0.573	0.240	0.135	0.004	55.0				
N-14	2.751	18	3.630	3.313	0.573	0.240	0.135	0.004	63.8				
AN-15	2.933	12	3.880	3.563	0.604	0.360	0.135	0.004	78.8				
AN-16	3.137	12	4.161	3.844	0.604	0.360	0.135	0.004	92.5				
AN-17	3.340	12	4.411	4.031	0.635	0.360	0.166	0.004	104.0				
AN-18	3.527	12	4.661	4.281	0.698	0.360	0.166	0.004	130.0				
AN-19	3.730	12	4.943	4.563	0.729	0.360	0.166	0.004	153.8				
AN-20	3.918	12	5.193	4.813	0.760	0.360	0.166	0.004	178.8				
AN-21	4.122	12	5.443	5.000	0.760	0.485	0.198	0.004	193.8				
AN-22	4.325	12	5.724	5.281	0.791	0.485	0.198	0.004	223.0				
AN-24	4.716	12	6.130	5.688	0.823	0.485	0.198	0.006	255.0				
AN-26	5.106	12	6.755	6.188	0.885	0.610	0.260	0.006	317.0				
AN-28	5.497	12	7.099	6.531	0.948	0.610	0.260	0.006	355.0				
AN-30	5.888	12	7.693	7.063	0.979	0.610	0.291	0.006	475.0				
AN-32	6.284	8	8.068	7.438	1.041	0.610	0.291	0.006	525.0				
AN-34	6.659	8	8.661	8.031	1.073	0.610	0.291	0.006	662.5				
AN-36	7.066	8	9.068	8.375	1.104	0.735	0.323	0.006	665.0				
AN-38	7.472	8	9.474	8.781	1.135	0.735	0.323	0.006	775.0				
AN-40	7.847	8	9.849	9.156	1.198	0.735	0.323	0.006	850.0				
N-44	8.628	8	11.005	9.843	1.260	0.980	0.510	0.006	1050.0				

NOTES:

Available in left hand thread (NL series), in stainless steel (NS series), or plated.

AN15-AN40 are available with 11 threads per in (N series).

K1 threads—American National Form NS Class 3.

N-00 SERIES LOCKNUTS



N-00 SERIES

SHAFT DIMENSIONS

Inch dimensions for ball, roller, spherical and tapered roller bearings

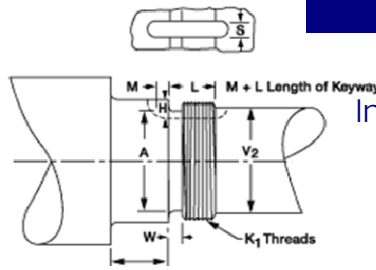
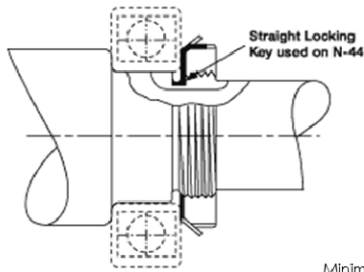

Minimum bearing width minus 0.016" (0.41 mm)

SHAFT DIMENSIONS

LOCKNUT NO.	BEARING BORE	V ₂ MAX.	NO. PER INCH	MAJOR DIA. MAX.	THREADS PITCH DIA. MAX.	MINOR DIA. MAX.	LENGTH L MAX.	RELIEF			KEYWAY WIDTH	
								DIA. A MAX.	WIDTH W MAX.	DEPTH H MIN.	WIDTH S MIN.	DEPTH M MIN.
N-00	0.394	0.312	32	0.391	0.371	0.353	0.297	0.342	0.078	0.062	0.125	0.094
N-01	0.472	0.406	32	0.469	0.449	0.431	0.391	0.420	0.078	0.062	0.125	0.094
N-02	0.591	0.500	32	0.586	0.566	0.548	0.391	0.537	0.078	0.078	0.125	0.094
N-03	0.669	0.562	32	0.664	0.644	0.626	0.422	0.615	0.078	0.078	0.125	0.094
N-04	0.787	0.719	32	0.781	0.761	0.743	0.453	0.732	0.078	0.078	0.188	0.094
N-05	0.984	0.875	32	0.969	0.949	0.931	0.484	0.920	0.078	0.094	0.188	0.125
N-06	1.181	1.062	18	1.173	1.137	1.105	0.484	1.094	0.109	0.094	0.188	0.125
N-07	1.378	1.250	18	1.376	1.340	1.308	0.516	1.297	0.109	0.094	0.188	0.125
N-08	1.575	1.469	18	1.563	1.527	1.495	0.547	1.484	0.109	0.094	0.312	0.125
N-09	1.772	1.688	18	1.767	1.731	1.699	0.547	1.688	0.141	0.094	0.312	0.156
N-10	1.969	1.875	18	1.967	1.931	1.899	0.609	1.888	0.141	0.094	0.312	0.156
N-11	2.165	2.062	18	2.157	2.121	2.089	0.609	2.078	0.141	0.125	0.312	0.156
N-12	2.362	2.250	18	2.360	2.324	2.292	0.641	2.281	0.141	0.125	0.312	0.156
N-13	2.559	2.438	18	2.548	2.512	2.480	0.672	2.469	0.141	0.125	0.312	0.156
N-14	2.756	2.625	18	2.751	2.715	2.683	0.672	2.672	0.141	0.125	0.312	0.250
AN-15	2.953	2.781	12	2.933	2.879	2.831	0.703	2.810	0.172	0.125	0.312	0.250
AN-16	3.150	3.000	12	3.137	3.083	3.035	0.703	3.014	0.172	0.125	0.375	0.250
AN-17	3.347	3.188	12	3.340	3.286	3.238	0.734	3.217	0.172	0.125	0.375	0.250
AN-18	3.543	3.375	12	3.527	3.473	3.425	0.828	3.404	0.172	0.156	0.375	0.250
AN-19	3.740	3.562	12	3.730	3.676	3.628	0.859	3.607	0.172	0.156	0.375	0.250
AN-20	3.937	3.781	12	3.918	3.864	3.816	0.891	3.795	0.172	0.156	0.375	0.312
AN-21	4.134	3.938	12	4.122	4.068	4.020	0.891	3.999	0.172	0.156	0.375	0.312
AN-22	4.331	4.188	12	4.325	4.271	4.223	0.922	4.202	0.172	0.188	0.375	0.312
AN-24	4.724	4.562	12	4.716	4.662	4.614	0.953	4.593	0.172	0.188	0.375	0.312
AN-26	5.118	4.938	12	5.106	5.052	5.004	1.016	4.983	0.172	0.188	0.500	0.312
AN-28	5.512	5.312	12	5.497	5.443	5.395	1.078	5.374	0.172	0.188	0.625	0.312
AN-30	5.906	5.719	12	5.888	5.834	5.786	1.141	5.765	0.172	0.219	0.625	0.375
AN-32	6.299	6.125	8	6.284	6.203	6.131	1.203	6.109	0.266	0.234	0.625	0.375
AN-34	6.693	6.500	8	6.659	6.578	6.506	1.234	6.484	0.266	0.234	0.750	0.375
AN-36	7.087	6.906	8	7.066	6.985	6.913	1.266	6.891	0.266	0.234	0.750	0.375
AN-38	7.480	7.312	8	7.472	7.391	7.319	1.297	7.297	0.266	0.234	0.750	0.375
AN-40	7.874	7.688	8	7.847	7.766	7.694	1.359	7.672	0.266	0.234	0.875	0.375
N-44	8.661	8.312	8	8.628	8.547	8.475	1.391	8.453	0.266	0.375	1.062	0.188

NOTES:

K1 threads—American National Form NS Class 3.



N-00 SERIES SHAFTS

N-000 SERIES

LOCKNUT DIMENSIONS

Inch dimensions for ball, roller, spherical and tapered roller bearings

Larger Bore Series

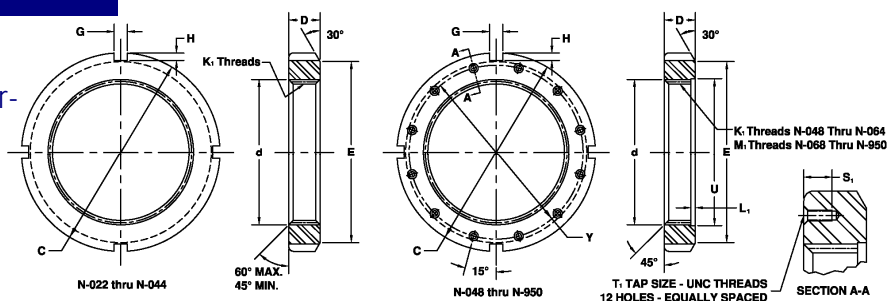

LOCKNUT DIMENSIONS

LOCKNUT NO.	THREADS			OUTSIDE DIA. C MAX.	FACE DIA. E MAX.	NUT WIDTH D MAX.	SLOT WIDTH G MAX.	SLOT DEPTH H MAX.	FACE RUNOUT S _d MAX.	COUNTERBORE		TAPPED HOLES FOR MOUNTING		
	MAJOR DIA. d MIN.	NO. PER INCH								DIA. U MIN.	DEPTH L ₁ MIN.	B.C. DIA. Y MIN.	TAP SIZE T ₁	DEPTH S ₁ MIN.
		K ₁	M ₁											
N-022	4.325	12		5.318	4.901	0.791	0.485	0.198	0.006					
N-024	4.716	12		5.693	5.313	0.823	0.485	0.198	0.006					
N-026	5.106	12		6.130	5.703	0.885	0.485	0.198	0.006					
N-028	5.497	12		6.505	6.109	0.948	0.485	0.198	0.006					
N-030	5.888	12		7.130	6.688	0.979	0.610	0.229	0.006					
N-032	6.284	8		7.505	7.094	1.041	0.610	0.229	0.006					
N-034	6.659	8		7.880	7.484	1.073	0.610	0.229	0.006					
N-036	7.066	8		8.255	7.875	1.104	0.610	0.229	0.006					
N-038	7.472	8		8.693	8.266	1.135	0.610	0.229	0.006					
N-040	7.847	8		9.443	8.750	1.198	0.735	0.323	0.006					
N-044	8.628	8		10.255	9.531	1.260	0.860	0.385	0.006					
N-048	9.442	6		11.443	10.625	1.354	0.860	0.385	0.008			10.423	5/16----18	0.625
N-052	10.192	6		12.193	11.406	1.416	0.860	0.385	0.008			11.298	5/16----18	0.625
N-056	11.004	6		13.005	12.219	1.510	0.980	0.385	0.008			12.110	5/16----18	0.625
N-060	11.785	6		14.193	13.219	1.573	0.980	0.510	0.008			13.110	3/8----16	0.750
N-064	12.562	6		15.005	14.031	1.666	0.980	0.510	0.008			13.860	3/8----16	0.750
N-068	13.339	5	5	15.755	14.813	1.791	0.980	0.510	0.008	13.355	0.375	14.735	3/8----16	0.750
N-072	14.170	5	5	16.505	15.500	1.791	1.230	0.510	0.008	14.186	0.375	15.485	3/8----16	0.750
N-076	14.957	5	5	17.755	16.625	1.916	1.230	0.604	0.008	14.973	0.375	16.485	1/2----13	0.875
N-080	15.745	5	5	18.505	17.438	2.073	1.230	0.604	0.008	15.761	0.375	17.235	1/2----13	0.875
N-084	16.532	5	5	19.318	18.188	2.073	1.355	0.604	0.008	16.548	0.375	18.110	1/2----13	0.875
N-088	17.319	5	5	20.505	19.250	2.385	1.355	0.604	0.008	17.335	0.375	19.110	5/8----11	1.250
N-092	18.107	5	5	21.255	20.688	2.385	1.355	0.604	0.008	18.123	0.375	19.985	5/8----11	1.250
N-096	18.894	5	5	22.068	20.750	2.385	1.480	0.604	0.010	18.910	0.375	20.673	5/8----11	1.250
N-500	19.682	5	5	22.818	21.688	2.703	1.480	0.604	0.010	19.698	0.375	21.610	5/8----11	1.250
N-530	20.867	4	4	24.818	23.250	2.703	1.605	0.823	0.010	20.887	0.500	23.360	5/8----11	1.250
N-560	22.048	4	4	25.568	24.000	2.953	1.605	0.823	0.010	22.068	0.500	24.110	5/8----11	1.250
N-600	23.623	4	4	27.568	26.000	2.953	1.605	0.823	0.010	23.643	0.500	25.923	5/8----11	1.250
N-630	24.804	4	4	28.755	27.125	2.953	1.855	0.823	0.010	24.824	0.500	27.235	5/8----11	1.250
N-670	26.379	4	4	30.693	29.125	3.140	1.855	0.823	0.010	26.399	0.500	28.985	5/8----11	1.250
N-710	27.961	3	3	32.693	30.688	3.578	1.980	1.010	0.012	27.988	0.688	30.610	5/8----11	1.250
N-750	29.536	3	3	34.255	32.313	3.578	2.230	1.010	0.012	29.563	0.688	32.235	5/8----11	1.250
N-800	31.504	3	3	36.255	34.250	3.578	2.230	1.010	0.012	31.531	0.688	34.610	5/8----11	1.250
N-850	33.473	3	3	38.568	36.375	3.578	2.480	1.010	0.012	33.500	0.688	36.485	3/4----10	1.500
N-900	35.441	3	3	40.568	38.375	3.953	2.480	1.010	0.012	35.468	0.688	38.610	3/4----10	1.500
N-950	37.410	3	3	43.005	40.500	3.953	2.480	1.010	0.012	37.437	0.688	40.610	3/4----10	1.500

NOTES:

K1 threads—American National Form NS Class 3.

M1 threads—ACME Class 3G General Purpose.

N-000 SERIES LOCKNUTS



N-000 SERIES

SHAFT DIMENSIONS

Inch dimensions for ball, roller, spherical and tapered roller bearings

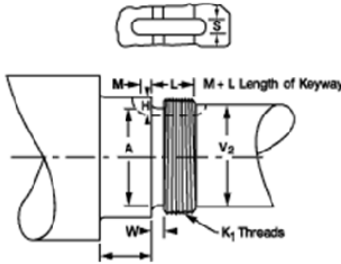

Minimum bearing width minus 0.016" (0.41 mm) N-022 thru N-044

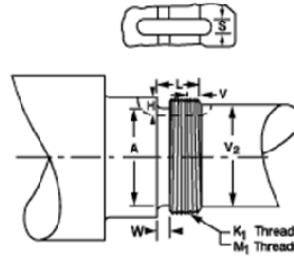

N-048 thru N-950

SHAFT DIMENSIONS

LOCKNUT NO.	BEARING BORE	THREADS						RELIEF			KEYWAY			
		NO. PER INCH		MAJOR DIA.	PITCH DIA.	MINOR DIA.	LENGTH	DIA.	WIDTH	DEPTH	WIDTH			
		V ₂ MAX.	K ₁	M ₁	MAX.	MAX.	MAX.	L MAX.	A MAX.	W MAX.	H MIN.	S MIN.	M MIN.	V MIN.
N-022	4.331	4.188	12		4.325	4.271	4.223	0.922	4.202	0.172	0.188	0.375	0.312	
N-024	4.724	4.562	12		4.716	4.662	4.614	0.953	4.593	0.172	0.188	0.375	0.312	
N-026	5.118	4.938	12		5.106	5.052	5.004	1.016	4.983	0.172	0.188	0.500	0.312	
N-028	5.512	5.312	12		5.497	5.443	5.395	1.078	5.374	0.172	0.188	0.625	0.312	
N-030	5.906	5.719	12		5.888	5.834	5.786	1.141	5.765	0.172	0.219	0.625	0.375	
N-032	6.299	6.125	8		6.284	6.203	6.131	1.203	6.109	0.266	0.234	0.625	0.375	
N-034	6.693	6.500	8		6.659	6.578	6.506	1.234	6.484	0.266	0.234	0.750	0.375	
N-036	7.087	6.906	8		7.066	6.985	6.913	1.266	6.891	0.266	0.234	0.750	0.375	
N-038	7.480	7.312	8		7.472	7.391	7.319	1.297	7.297	0.266	0.234	0.750	0.375	
N-040	7.874	7.688	8		7.847	7.766	7.694	1.359	7.672	0.266	0.234	0.875	0.375	
N-044	8.661	8.312	8		8.628	8.547	8.475	1.391	8.453	0.266	0.375	1.062	0.188	
N-048	9.449	9.188	6		9.442	9.334	9.237	1.734	9.201	0.266	0.438	1.125		0.500
N-052	10.236	9.938	6		10.192	10.084	9.987	1.797	9.951	0.266	0.438	1.188		0.500
N-056	11.024	10.750	6		11.004	10.896	10.799	1.891	10.763	0.266	0.438	1.250		0.500
N-060	11.811	11.500	6		11.785	11.677	11.580	1.953	11.544	0.266	0.438	1.375		0.500
N-064	12.598	12.312	6		12.562	12.454	12.357	2.047	12.321	0.266	0.438	1.438		0.500
N-068	13.386	13.062	5	5	13.303	13.203	13.083	2.172	13.046	0.266	0.438	1.500		0.500
N-072	14.173	13.812	5	5	14.134	14.034	13.914	2.172	13.877	0.266	0.500	1.500		0.500
N-076	14.961	14.625	5	5	14.921	14.821	14.701	2.297	14.664	0.266	0.500	1.500		0.500
N-080	15.748	15.375	5	5	15.709	15.609	15.489	2.453	15.452	0.266	0.500	1.625		0.500
N-084	16.535	16.188	5	5	16.496	16.396	16.276	2.453	16.239	0.266	0.500	1.625		0.500
N-088	17.323	17.000	5	5	17.283	17.183	17.063	2.766	17.026	0.266	0.500	1.812		0.500
N-092	18.110	17.750	5	5	18.071	17.971	17.851	2.766	17.814	0.266	0.500	1.812		0.500
N-096	18.898	18.500	5	5	18.858	18.758	18.638	2.766	18.601	0.266	0.500	1.812		0.500
N-500	19.685	19.250	5	5	19.646	19.546	19.426	3.141	19.389	0.266	0.500	1.812		0.500
N-530	20.866	20.250	4	4	20.827	20.702	20.557	3.141	20.504	0.266	0.500	1.812		0.500
N-560	22.047	21.500	4	4	22.008	21.883	21.738	3.391	21.685	0.266	0.500	1.812		0.500
N-600	23.622	23.000	4	4	23.583	23.458	23.313	3.391	23.260	0.266	0.500	1.812		0.500
N-630	24.803	24.250	4	4	24.764	24.639	24.494	3.391	24.441	0.266	0.500	2.000		0.500
N-670	26.378	25.750	4	4	26.339	26.214	26.069	3.578	26.016	0.266	0.500	2.000		0.500
N-710	27.953	27.250	3	3	27.914	27.747	27.560	4.109	27.507	0.391	0.625	2.000		0.500
N-750	29.528	28.750	3	3	29.489	29.322	29.135	4.141	29.082	0.391	0.625	2.000		0.500
N-800	31.496	30.750	3	3	31.457	31.290	31.103	4.141	31.050	0.391	0.625	2.000		0.500
N-850	33.465	32.750	3	3	33.426	33.259	33.072	4.141	33.019	0.391	0.625	2.000		0.500
N-900	35.433	34.750	3	3	35.394	35.227	35.040	4.516	34.987	0.391	0.625	2.000		0.500
N-950	37.402	36.750	3	3	37.363	37.196	37.009	4.516	36.956	0.391	0.750	2.000		0.500

NOTES:

K1 threads—American National Form NS Class 3.

M1 threads—ACME Class 3G General Purpose.



N-000 SERIES SHAFTS

PRN/PRL-00 SERIES

LOCKNUT DIMENSIONS

Inch dimensions for ball, roller, spherical and tapered roller bearings

Tighter Face Runout Tolerance

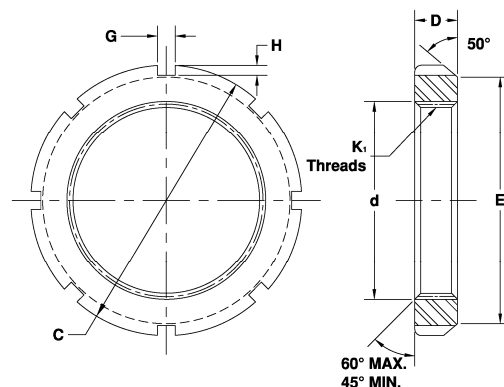

LOCKNUT DIMENSIONS

LOCKNUT NO.	THREADS		OUTSIDE DIA.		FACE DIA.		NUT WIDTH		SLOT		FACE RUNOUT		APP. WT. (LB./C)
	MAJOR DIA. d	NO. PER INCH K ₁	C	MAX.	E	MAX.	D	MAX.	G	MAX.	H	S _a	
	MIN.										MAX.		
PRN-00	0.391	32	0.755		0.625		0.229		0.120		0.073	0.001	2.0
PRN-01	0.469	32	0.880		0.719		0.323		0.120		0.073	0.001	3.3
PRN-02	0.586	32	1.005		0.813		0.323		0.120		0.104	0.001	3.5
PRN-03	0.664	32	1.130		0.938		0.354		0.120		0.104	0.001	5.3
PRN-04	0.781	32	1.380		1.125		0.385		0.178		0.104	0.001	9.0
PRN-05	0.969	32	1.568		1.281		0.416		0.178		0.104	0.001	11.5
PRN-06	1.173	18	1.755		1.500		0.416		0.178		0.104	0.001	13.0
PRN-07	1.376	18	2.068		1.813		0.448		0.178		0.104	0.001	21.0
PRN-08	1.563	18	2.255		2.000		0.448		0.240		0.104	0.001	22.5
PRN-09	1.767	18	2.536		2.281		0.448		0.240		0.104	0.001	29.0
PRN-10	1.967	18	2.693		2.438		0.510		0.240		0.104	0.001	34.0
PRN-11	2.157	18	2.974		2.656		0.510		0.240		0.135	0.001	42.0
PRN-12	2.360	18	3.161		2.844		0.541		0.240		0.135	0.001	47.0
PRN-13	2.548	18	3.380		3.063		0.573		0.240		0.135	0.001	55.0
PRN-14	2.751	18	3.630		3.313		0.573		0.240		0.135	0.001	63.8
PRN-15	2.933	12	3.880		3.563		0.604		0.360		0.135	0.001	78.8
PRN-16	3.137	12	4.161		3.844		0.604		0.360		0.135	0.001	92.5
PRN-17	3.340	12	4.411		4.031		0.635		0.360		0.166	0.001	104.0
PRN-18	3.527	12	4.661		4.281		0.698		0.360		0.166	0.001	130.0
PRN-19	3.730	12	4.943		4.563		0.729		0.360		0.166	0.001	153.8
PRN-20	3.918	12	5.193		4.813		0.760		0.360		0.166	0.001	178.8
PRN-21	4.122	12	5.443		5.000		0.760		0.485		0.198	0.001	193.8
PRN-22	4.325	12	5.724		5.281		0.791		0.485		0.198	0.001	223.0
PRN-24	4.716	12	6.130		5.688		0.823		0.485		0.198	0.002	255.0
PRN-26	5.106	12	6.755		6.188		0.885		0.610		0.260	0.002	317.0
PRN-28	5.497	12	7.099		6.531		0.948		0.610		0.260	0.002	355.0
PRN-30	5.888	12	7.693		7.063		0.979		0.610		0.291	0.002	475.0
PRN-32	6.284	8	8.068		7.438		1.041		0.610		0.291	0.002	525.0
PRN-34	6.659	8	8.661		8.031		1.073		0.610		0.291	0.002	662.5
PRN-36	7.066	8	9.068		8.375		1.104		0.735		0.323	0.002	665.0
PRN-38	7.472	8	9.474		8.781		1.135		0.735		0.323	0.002	775.0
PRN-40	7.847	8	9.849		9.156		1.198		0.735		0.323	0.002	850.0

NOTES:

This series has a tighter face runout tolerance than the standard N/AN series.

Also available in left hand thread , specify "PRL" series.

K1 Threads—American National Form NS Class 3.

PRN/PRL-00 SERIES LOCKNUTS



PRT-00 SERIES

LOCKNUT DIMENSIONS

Inch dimensions for ball, roller, spherical and tapered roller bearings

Narrow Versions of N Series

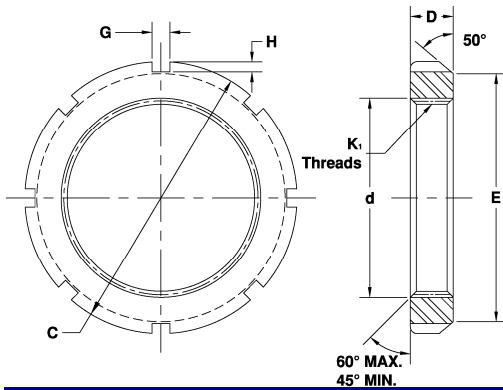

LOCKNUT DIMENSIONS

LOCKNUT NO.	MAJOR DIA. d MIN.	THREADS NO. PER INCH K ₁	OUTSIDE DIA. C MAX.	FACE DIA. E MAX.	NUT WIDTH D MAX.	SLOT WIDTH G MAX.	SLOT DEPTH H MAX.	FACE RUNOUT S _d MAX.	APP. WT. (LB./C)
PRT-00	0.391	32	0.724	0.531	0.198	0.120	0.065	0.001	1.7
PRT-01	0.469	32	0.818	0.625	0.198	0.120	0.065	0.001	2.1
PRT-02	0.586	32	0.943	0.750	0.229	0.120	0.065	0.001	3.0
PRT-03	0.664	32	1.067	0.875	0.229	0.120	0.065	0.001	3.8
PRT-04	0.781	32	1.193	1.000	0.260	0.178	0.080	0.001	5.0
PRT-05	0.969	32	1.380	1.188	0.260	0.178	0.065	0.001	6.0
PRT-06	1.173	18	1.693	1.438	0.260	0.178	0.096	0.001	9.4
PRT-07	1.376	18	1.911	1.656	0.291	0.178	0.096	0.001	12.4
PRT-08	1.563	18	2.099	1.844	0.291	0.240	0.096	0.001	13.9
PRT-09	1.767	18	2.317	2.062	0.291	0.240	0.096	0.001	15.9
PRT-10	1.967	18	2.505	2.250	0.322	0.240	0.096	0.001	18.9
PRT-11	2.157	18	2.755	2.500	0.322	0.240	0.096	0.001	22.8
PRT-12	2.360	18	2.942	2.688	0.322	0.240	0.096	0.001	24.1
PRT-13	2.548	18	3.130	2.875	0.354	0.240	0.096	0.001	28.4
PRT-14	2.751	18	3.349	3.094	0.354	0.240	0.096	0.001	31.3
PRT-15	2.933	12	3.693	3.375	0.354	0.360	0.128	0.001	43.7
PRT-16	3.137	12	3.911	3.594	0.385	0.360	0.128	0.001	51.5
PRT-17	3.340	12	4.130	3.812	0.385	0.360	0.128	0.001	55.6
PRT-18	3.527	12	4.317	4.000	0.385	0.360	0.128	0.001	58.4

NOTES:

This series is designed to accommodate limited space applications where high precision is required.



PRT-00 SERIES LOCKNUTS

SN-00 SERIES

LOCKNUT DIMENSIONS

Inch dimensions for ball, roller, spherical and tapered roller bearings

Self Locking

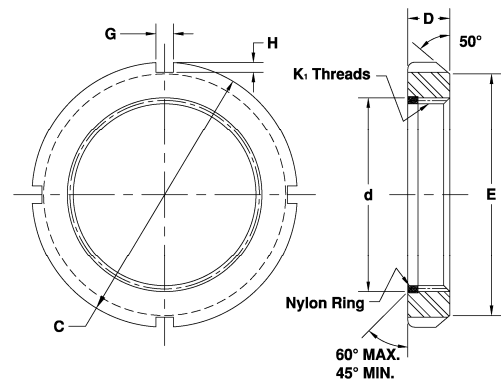

LOCKNUT DIMENSIONS

LOCKNUT NO.	MAJOR DIA. d MIN.	THREADS NO. PER INCH K ₁	OUTSIDE DIA. C MAX.	FACE DIA. E MAX.	NUT WIDTH D MAX.	SLOT WIDTH G MAX.	SLOT DEPTH H MAX.	FACE RUNOUT S _a MAX.	APP. WT. (LB./C)
SN-00	0.391	32	0.755	0.625	0.276	0.120	0.073	0.002	2.0
SN-01	0.469	32	0.880	0.719	0.369	0.120	0.073	0.002	3.3
SN-02	0.586	32	1.005	0.813	0.369	0.120	0.104	0.002	3.5
SN-03	0.664	32	1.130	0.938	0.401	0.120	0.104	0.002	5.3
SN-04	0.781	32	1.380	1.125	0.432	0.178	0.104	0.002	9.0
SN-05	0.969	32	1.568	1.281	0.463	0.178	0.104	0.002	11.5
SN-06	1.173	18	1.755	1.500	0.463	0.178	0.104	0.002	13.0
SN-07	1.376	18	2.068	1.813	0.510	0.178	0.104	0.004	21.0
SN-08	1.563	18	2.255	2.000	0.510	0.240	0.104	0.004	22.5
SN-09	1.767	18	2.536	2.281	0.510	0.240	0.104	0.004	29.0
SN-10	1.967	18	2.693	2.438	0.573	0.240	0.104	0.004	34.0
SN-11	2.157	18	2.974	2.656	0.573	0.240	0.135	0.004	42.0
SN-12	2.360	18	3.161	2.844	0.604	0.240	0.135	0.004	47.0
SN-13	2.548	18	3.380	3.063	0.635	0.240	0.135	0.004	55.0
SN-14	2.751	18	3.630	3.313	0.635	0.240	0.135	0.004	63.8
SN-15	2.933	12	3.880	3.563	0.604	0.360	0.135	0.004	78.8
SN-16	3.137	12	4.161	3.844	0.604	0.360	0.135	0.004	92.5
SN-17	3.340	12	4.411	4.031	0.635	0.360	0.166	0.004	104.0
SN-18	3.527	12	4.661	4.281	0.698	0.360	0.166	0.004	130.0
SN-19	3.730	12	4.943	4.563	0.729	0.360	0.166	0.004	153.8
SN-20	3.918	12	5.193	4.813	0.760	0.360	0.166	0.004	178.8
SN-21	4.122	12	5.443	5.000	0.760	0.485	0.198	0.004	193.8
SN-22	4.325	12	5.724	5.281	0.791	0.485	0.198	0.004	223.0
SN-24	4.716	12	6.130	5.688	0.823	0.485	0.198	0.006	255.0
SN-26	5.106	12	6.755	6.188	0.885	0.610	0.260	0.006	317.0
SN-28	5.497	12	7.099	6.531	0.948	0.610	0.260	0.006	355.0
SN-30	5.888	12	7.693	7.063	0.979	0.610	0.291	0.006	475.0
SN-32	6.284	8	8.068	7.438	1.041	0.610	0.291	0.006	525.0
SN-34	6.659	8	8.661	8.031	1.073	0.610	0.291	0.006	662.5
SN-36	7.066	8	9.068	8.375	1.104	0.735	0.323	0.006	665.0
SN-38	7.472	8	9.474	8.781	1.135	0.735	0.323	0.006	775.0
SN-40	7.847	8	9.849	9.156	1.198	0.735	0.323	0.006	850.0

NOTES:

This series is designed with a "Self-Locking" nylon insert which eliminates the need for a lockwasher and shaft keyway. Also available in left hand thread (SNL), metric (SM) and stainless steel (SNS).

K1 Threads—American National Form NS Class 3.

SN/SNL-00 SERIES LOCKNUTS



SNH-00 SERIES

LOCKNUT DIMENSIONS

Inch dimensions for ball, roller, spherical and tapered roller bearings

Self-Locking and High Temperature

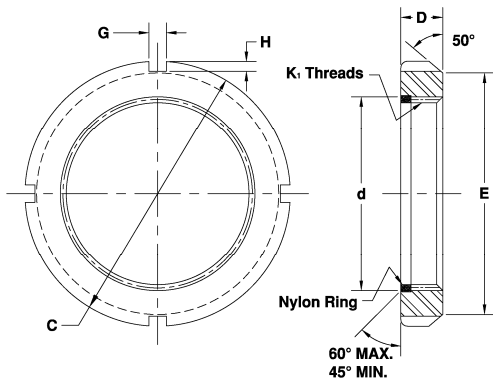

LOCKNUT DIMENSIONS

LOCKNUT NO.	THREADS		OUTSIDE DIA. C MAX.	FACE DIA. E MAX.	NUT WIDTH D MAX.	SLOT WIDTH G MAX.	SLOT DEPTH H MAX.
	MAJOR DIA. d MIN.	NO. PER INCH K ₁					
SNH-00	0.391	32	0.755	0.625	0.229	0.120	0.073
SNH-01	0.469	32	0.880	0.719	0.323	0.120	0.073
SNH-02	0.586	32	1.005	0.813	0.323	0.120	0.104
SNH-03	0.664	32	1.130	0.938	0.354	0.120	0.104
SNH-04	0.781	32	1.380	1.125	0.385	0.178	0.104
SNH-05	0.969	32	1.568	1.281	0.416	0.178	0.104
SNH-06	1.173	18	1.755	1.500	0.416	0.178	0.104
SNH-07	1.376	18	2.068	1.813	0.448	0.178	0.104
SNH-08	1.563	18	2.255	2.000	0.448	0.240	0.104
SNH-09	1.767	18	2.536	2.281	0.448	0.240	0.104
SNH-10	1.967	18	2.693	2.438	0.510	0.240	0.104
SNH-11	2.157	18	2.974	2.656	0.510	0.240	0.135
SNH-12	2.360	18	3.161	2.844	0.541	0.240	0.135
SNH-13	2.548	18	3.380	3.063	0.573	0.240	0.135
SNH-14	2.751	18	3.630	3.313	0.573	0.240	0.135
SNH-15	2.933	12	3.880	3.563	0.604	0.360	0.135
SNH-16	3.137	12	4.161	3.844	0.604	0.360	0.135
SNH-17	3.340	12	4.411	4.031	0.635	0.360	0.166
SNH-18	3.527	12	4.661	4.281	0.698	0.360	0.166
SNH-19	3.730	12	4.943	4.563	0.729	0.360	0.166
SNH-20	3.918	12	5.193	4.813	0.760	0.360	0.166
SNH-21	4.122	12	5.443	5.000	0.760	0.485	0.198
SNH-22	4.325	12	5.724	5.281	0.791	0.485	0.198

NOTES:

This series is designed with a "Self-Locking" nylon insert which can accommodate temperatures up to 350°F.

K1 Threads—American National Form Class 3.



SNH-00 SERIES LOCKNUTS

NHE-00 SERIES

LOCKNUT DIMENSIONS

Inch dimensions for ball, roller, spherical and tapered roller bearings

Heavy Load

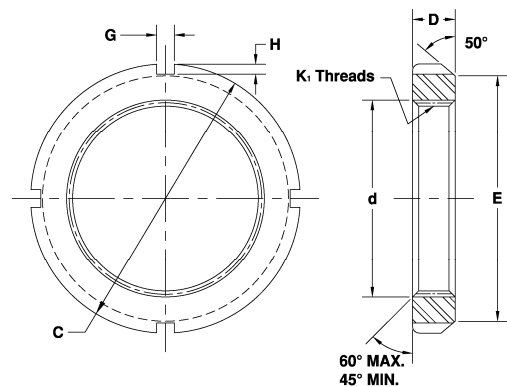

LOCKNUT DIMENSIONS

LOCKNUT NO.	THREADS		OUTSIDE DIA. C MAX.	FACE DIA.		NUT WIDTH D MAX.	SLOT WIDTH G MAX.	SLOT DEPTH H MAX.	FACE RUNOUT S _d MAX.	APP. WT. (LB./C)
	MAJOR DIA. d MIN.	NO. PER INCH K ₁		E MAX.	E MAX.					
NHE-08	1.563	18	2.255	2.000	0.572	0.240	0.104	0.002	35.7	
NHE-09	1.767	18	2.536	2.281	0.572	0.240	0.104	0.002	44.4	
NHE-10	1.967	18	2.693	2.438	0.635	0.240	0.104	0.002	50.7	
NHE-11	2.157	18	2.974	2.656	0.635	0.240	0.135	0.002	62.4	
NHE-12	2.360	18	3.161	2.844	0.666	0.240	0.135	0.002	69.3	
NHE-13	2.548	18	3.380	3.063	0.729	0.240	0.135	0.002	84.4	
NHE-14	2.751	18	3.630	3.313	0.729	0.240	0.135	0.002	95.7	
NHE-15	2.933	12	3.880	3.563	0.760	0.360	0.135	0.002	117.9	
NHE-16	3.137	12	4.161	3.844	0.760	0.360	0.135	0.002	135.9	
NHE-17	3.340	12	4.411	4.031	0.791	0.360	0.166	0.002	156.5	
NHE-18	3.527	12	4.661	4.281	0.885	0.360	0.166	0.002	195.2	
NHE-19	3.730	12	4.943	4.563	0.916	0.360	0.166	0.002	227.9	
NHE-20	3.918	12	5.193	4.813	0.948	0.360	0.166	0.002	259.7	
NHE-21	4.122	12	5.443	5.000	0.948	0.485	0.198	0.002	282.0	
NHE-22	4.325	12	5.724	5.281	0.979	0.485	0.198	0.002	323.0	
NHE-24	4.716	12	6.130	5.688	1.041	0.485	0.198	0.002	374.7	
NHE-26	5.106	12	6.755	6.188	1.104	0.610	0.260	0.002	502.8	
NHE-28	5.497	12	7.099	6.531	1.198	0.610	0.260	0.002	564.0	
NHE-30	5.888	12	7.693	7.063	1.260	0.610	0.291	0.002	716.7	
NHE-32	6.284	8	8.068	7.438	1.291	0.610	0.291	0.002	783.7	
NHE-34	6.659	8	8.661	8.031	1.354	0.610	0.291	0.002	977.6	
NHE-36	7.066	8	9.068	8.375	1.416	0.735	0.323	0.002	1077.2	
NHE-38	7.472	8	9.474	8.781	1.416	0.735	0.323	0.002	1131.8	
NHE-40	7.847	8	9.849	9.156	1.510	0.735	0.323	0.002	1260.8	

NOTES:

This series is designed with a wider nut width (D) to accommodate heavier loads.
K1 Threads—American National Form NS Class 3.

NHE-00 SERIES LOCKNUTS



NIN-00 SERIES

LOCKNUT DIMENSIONS

Inch dimensions for ball, roller, spherical and tapered roller bearings

16 Threads per Inch

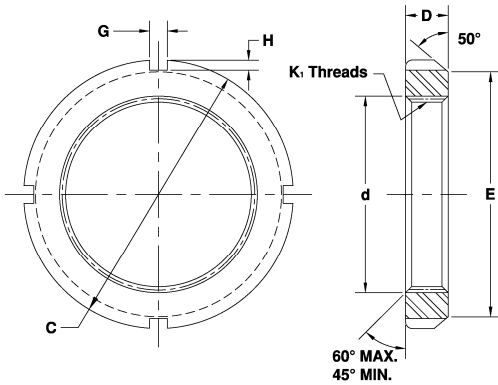

LOCKNUT DIMENSIONS

LOCKNUT NO.	MAJOR DIA. d	THREADS NO. PER INCH K ₁	OUTSIDE DIA. C	FACE DIA. E	NUT WIDTH D	SLOT WIDTH G	SLOT DEPTH H	FACE RUNOUT S _d	APP. WT. (LB./C)
	MIN.		MAX.	MAX.	MAX.	MAX.	MAX.	MAX.	
NIN-01	0.750	16	1.505	1.188	0.385	0.240	0.138	0.002	14.5
NIN-02	0.875	16	1.630	1.313	0.385	0.240	0.138	0.002	16.1
NIN-03	1.000	16	1.755	1.438	0.385	0.240	0.138	0.002	17.7
NIN-04	1.125	16	1.880	1.563	0.385	0.240	0.138	0.002	19.3
NIN-05	1.250	16	2.005	1.688	0.510	0.240	0.138	0.004	27.7
NIN-06	1.375	16	2.255	1.938	0.510	0.240	0.138	0.004	36.0
NIN-07	1.500	16	2.255	1.938	0.510	0.240	0.138	0.004	32.0
NIN-08	1.625	16	2.505	2.188	0.510	0.302	0.138	0.004	41.0
NIN-09	1.750	16	2.630	2.313	0.510	0.302	0.138	0.004	43.4
NIN-10	1.875	16	2.755	2.438	0.510	0.302	0.138	0.004	45.9
NIN-11	2.000	16	3.005	2.688	0.510	0.302	0.138	0.004	56.7
NIN-12	2.250	16	3.255	2.875	0.635	0.302	0.169	0.004	77.7
NIN-13	2.500	16	3.505	3.125	0.635	0.302	0.169	0.004	84.8
NIN-14	2.750	16	3.755	3.375	0.635	0.302	0.169	0.004	91.8

NOTES:

K1 Threads—American National Form Class 3.



NIN-00 SERIES LOCKNUTS

NTH-00 SERIES

LOCKNUT DIMENSIONS

Inch dimensions for ball, roller, spherical and tapered roller bearings

Thinner Design

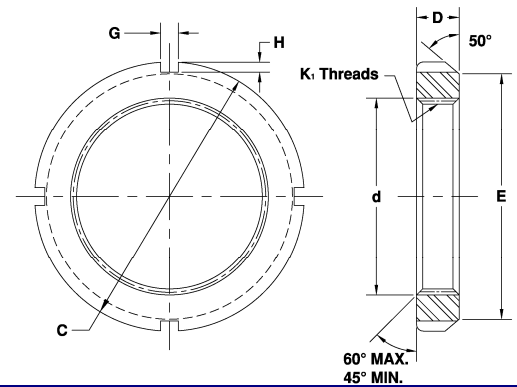

LOCKNUT DIMENSIONS

LOCKNUT NO.	MAJOR DIA. d MIN.	THREADS NO. PER INCH K ₁	OUTSIDE DIA. C MAX.	FACE DIA. E MAX.	NUT WIDTH D MAX.	SLOT WIDTH G MAX.	SLOT DEPTH H MAX.	FACE RUNOUT S _d MAX.	APP. WT. (LB./C)
NTH-00	0.391	32	0.724	0.531	0.198	0.120	0.065	0.002	1.7
NTH-01	0.469	32	0.818	0.625	0.198	0.120	0.065	0.002	2.1
NTH-02	0.586	32	0.943	0.750	0.229	0.120	0.065	0.002	3.0
NTH-03	0.664	32	1.068	0.875	0.229	0.120	0.065	0.002	3.8
NTH-04	0.781	32	1.193	1.000	0.260	0.178	0.080	0.002	5.0
NTH-05	0.969	32	1.380	1.188	0.260	0.178	0.065	0.002	6.0
NTH-06	1.173	18	1.693	1.438	0.260	0.178	0.096	0.002	9.4
NTH-07	1.376	18	1.911	1.656	0.291	0.178	0.096	0.004	12.4
NTH-08	1.563	18	2.099	1.844	0.291	0.240	0.096	0.004	13.9
NTH-09	1.767	18	2.318	2.062	0.291	0.240	0.096	0.004	15.9
NTH-10	1.967	18	2.505	2.250	0.322	0.240	0.096	0.004	18.9
NTH-11	2.157	18	2.755	2.500	0.322	0.240	0.096	0.004	22.8
NTH-12	2.360	18	2.943	2.688	0.322	0.240	0.096	0.004	24.1
NTH-13	2.548	18	3.130	2.875	0.354	0.240	0.096	0.004	28.4
NTH-14	2.751	18	3.349	3.094	0.354	0.240	0.096	0.004	31.3
NTH-15	2.933	12	3.693	3.375	0.354	0.360	0.128	0.004	43.7
NTH-16	3.137	12	3.911	3.594	0.385	0.360	0.128	0.004	51.5
NTH-17	3.340	12	4.130	3.812	0.385	0.360	0.128	0.004	55.6
NTH-18	3.527	12	4.318	4.000	0.385	0.360	0.128	0.004	58.4

NOTES:

This series is designed with a thinner width (D) to accommodate narrow spaces.
K1 Threads—American National Form NS Class 3.

NTH-00 SERIES LOCKNUTS



KM-00 SERIES

LOCKNUT DIMENSIONS

Metric dimensions for ball, roller, spherical and tapered roller bearings

Metric Design

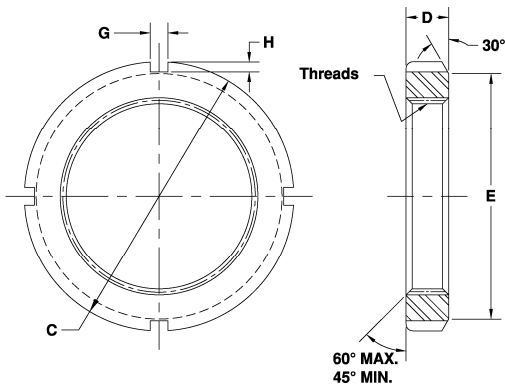

LOCKNUT DIMENSIONS

LOCKNUT NO.	METRIC THREADS	OUTSIDE DIA. C	FACE DIA. E	NUT WIDTH D	SLOT WIDTH G	SLOT DEPTH H	FACE RUNOUT S _a
		MAX.	MAX.	MAX.	MAX.	MAX.	MAX.
KM 0	M 10x0.75	0.709	0.531	0.157	0.118	0.079	0.002
KM 1	M 12x1	0.866	0.669	0.157	0.118	0.079	0.002
KM 2	M 15x1	0.984	0.827	0.197	0.157	0.079	0.002
KM 3	M 17x1	1.102	0.945	0.197	0.157	0.079	0.002
KM 4	M 20x1	1.260	1.024	0.236	0.157	0.079	0.002
KM 4.4	M 22x1	1.339	1.102	0.236	0.157	0.079	0.002
KM 5	M 25x1.5	1.496	1.206	0.276	0.197	0.079	0.002
KM 5.6	M 28x1.5	1.654	1.417	0.276	0.197	0.079	0.002
KM 6	M 30x1.5	1.772	1.496	0.276	0.197	0.079	0.002
KM 6.4	M 32x1.5	1.890	1.575	0.315	0.197	0.079	0.002
KM 7	M 35x1.5	2.047	1.732	0.315	0.197	0.079	0.002
KM 8	M 40x1.5	2.283	1.969	0.354	0.236	0.098	0.002
KM 9	M 45x1.5	2.559	2.205	0.394	0.236	0.098	0.002
KM 10	M 50x1.5	2.756	2.402	0.433	0.236	0.098	0.002
KM 11	M 55x2	2.953	2.638	0.433	0.276	0.118	0.002
KM 12	M 60x2	3.150	2.874	0.433	0.276	0.118	0.002
KM 13	M 65x2	3.346	3.110	0.472	0.276	0.118	0.002
KM 14	M 70x2	3.622	3.346	0.472	0.315	0.138	0.002
KM 15	M 75x2	3.858	3.543	0.512	0.315	0.138	0.002
KM 16	M 80x2	4.134	3.740	0.591	0.315	0.138	0.002
KM 17	M 85x2	4.331	4.016	0.630	0.315	0.138	0.002
KM 18	M 90x2	4.724	4.252	0.630	0.394	0.157	0.002
KM 19	M 95x2	4.921	4.449	0.669	0.394	0.157	0.002
KM 20	M100x2	5.118	4.724	0.709	0.394	0.157	0.002
KM 21	M105x2	5.512	4.961	0.709	0.472	0.197	0.002
KM 22	M110x2	5.709	5.236	0.748	0.472	0.197	0.002
KM 23	M115x2	5.906	5.394	0.748	0.472	0.197	0.002
KM 24	M120x2	6.102	5.433	0.787	0.472	0.197	0.002
KM 25	M125x2	6.299	5.827	0.827	0.472	0.197	0.002
KM 26	M130x2	6.496	5.866	0.827	0.472	0.197	0.002
KM 27	M135x2	6.890	6.299	0.866	0.551	0.236	0.002
KM 28	M140x2	7.087	6.299	0.866	0.551	0.236	0.002
KM 29	M145x2	7.480	6.732	0.945	0.551	0.236	0.002
KM 30	M150x2	7.677	6.732	0.945	0.551	0.236	0.002
KM 31	M155x3	7.874	7.165	0.984	0.630	0.276	0.002
KM 32	M160x3	8.268	7.165	0.984	0.630	0.276	0.002
KM 33	M165x3	8.268	7.598	1.024	0.630	0.276	0.002
KM 34	M170x3	8.661	7.598	1.024	0.630	0.276	0.002
KM 36	M180x3	9.055	7.992	1.063	0.709	0.315	0.002
KM 38	M190x3	9.449	8.425	1.102	0.709	0.315	0.002
KM 40	M200x3	9.843	8.898	1.142	0.709	0.315	0.002
KM 44	Tr220x3	11.024	9.843	1.260	0.787	0.394	0.002
KM 48	Tr240x4	11.811	10.630	1.339	0.787	0.394	0.002
KM 52	Tr260x4	12.992	11.811	1.417	0.945	0.472	0.003
KM 56	Tr280x4	13.780	12.598	1.496	0.945	0.472	0.003

NOTES:

KM0—KM34 are available with 360° insert. Also available in stainless steel. HM-Series Locknuts are also available.



KM-00 SERIES LOCKNUTS



Lockwashers

Bearing Accessories



W-00 & W-000 SERIES

LOCKWASHER DIMENSIONS

For use with N and AN Locknut Series

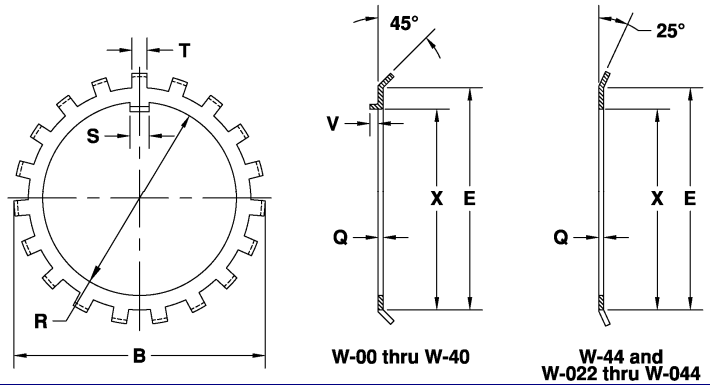

W-00 thru W-40

W-44 and W-022 thru W-044

LOCKWASHER DIMENSIONS

LOCKWASHER NO.		BORE		FACE DIAMETER		DIA. OVER TANGS		KEY WIDTH		INSIDE DIMENSION	NO. OF TANGS	PROJECTION	TANG WIDTH		TANG THICKNESS		APP. WT. (LB./C)
		R	E	E		B		S	X	X		V	T	Q	Q		
		MIN.	MIN.	W-00	W-000	W-00	W-000	W-00	W-000	MIN.		MIN.	W-00	W-00	W-000	W-00	W-000
W-00	W-000	0.406	0.625			0.875		0.120		0.334	9	0.063	0.120			0.032	0.50
W-01		0.484	0.719			1.016		0.120		0.412	9	0.063	0.120			0.032	0.50
W-02		0.601	0.813			1.156		0.120		0.529	11	0.063	0.120			0.032	0.50
W-03		0.679	0.938			1.328		0.120		0.607	11	0.063	0.120			0.032	0.80
W-04		0.801	1.125			1.531		0.176		0.729	11	0.063	0.166			0.032	1.30
W-05		0.989	1.281			1.719		0.176		0.909	13	0.094	0.166			0.040	1.50
W-06		1.193	1.500			1.922		0.176		1.093	13	0.094	0.166			0.040	1.50
W-07		1.396	1.813			2.250		0.176		1.296	15	0.094	0.166			0.040	2.30
W-08		1.583	2.000			2.496		0.290		1.475	15	0.094	0.234			0.048	3.30
W-09		1.792	2.281			2.734		0.290		1.684	17	0.125	0.234			0.048	4.30
W-10		1.992	2.438			2.922		0.290		1.884	17	0.125	0.234			0.048	4.50
W-11		2.182	2.656			3.109		0.290		2.069	17	0.125	0.234			0.053	4.80
W-12		2.400	2.844			3.344		0.290		2.267	17	0.125	0.234			0.053	4.80
W-13		2.588	3.063			3.578		0.290		2.455	19	0.125	0.234			0.053	6.00
W-14		2.791	3.313			3.828		0.290		2.658	19	0.188	0.234			0.053	6.50
W-15		2.973	3.563			4.109		0.290		2.831	19	0.188	0.328			0.062	10.00
W-16		3.177	3.844			4.375		0.353		3.035	19	0.188	0.328			0.062	11.50
W-17		3.395	4.031			4.625		0.353		3.253	19	0.188	0.328			0.062	12.00
W-18		3.582	4.281			4.938		0.353		3.418	19	0.188	0.328			0.084	16.80
W-19		3.800	4.563			5.219		0.353		3.636	19	0.188	0.328			0.084	19.50
W-20		3.988	4.813			5.500		0.353		3.809	19	0.250	0.328			0.084	20.50
W-21		4.192	5.000			5.703		0.353		4.013	19	0.250	0.390			0.084	23.80
W-22	W-022	4.395	5.281	4.921		6.063	5.688	0.353	0.350	4.185	19	0.250	0.390	0.390	0.115	0.115	34.50
W-24	W-024	4.801	5.688	5.333		6.469	6.188	0.353	0.350	4.591	19	0.250	0.390	0.390	0.115	0.115	39.00
W-26	W-026	5.191	6.188	5.723		7.031	6.625	0.435	0.469	4.961	19	0.250	0.520	0.390	0.115	0.115	43.00
W-28	W-028	5.582	6.531	6.129		7.438	7.094	0.590	0.594	5.352	19	0.250	0.520	0.390	0.115	0.115	46.50
W-30	W-030	5.983	7.063	6.708		8.063	7.719	0.590	0.594	5.722	19	0.312	0.520	0.520	0.146	0.115	71.00
W-32	W-032	6.389	7.438	7.114		8.438	8.156	0.590	0.594	6.128	19	0.312	0.520	0.520	0.146	0.115	73.50
W-34	W-034	6.764	8.031	7.508		9.063	8.594	0.715	0.719	6.503	19	0.312	0.520	0.520	0.146	0.115	90.50
W-36	W-036	7.171	8.375	7.899		9.438	9.000	0.715	0.719	6.910	19	0.312	0.645	0.520	0.146	0.115	93.50
W-38	W-038	7.577	8.781	8.290		9.875	9.438	0.715	0.719	7.316	19	0.312	0.645	0.520	0.146	0.115	105.00
W-40	W-040	7.982	9.156	8.774		10.313	9.969	0.840	0.844	7.721	19	0.312	0.645	0.645	0.146	0.115	111.00
W-44	W-044	8.701	9.875	9.570		11.438	10.406	0.940	0.945	8.327	19		0.878	0.770	0.146	0.115	118.00

LOCKWASHERS



PRW-00 & PRWT-00 SERIES

LOCKWASHER DIMENSIONS

PRW for use with PRN and PRL

Precision Locknut Series.

PRWT for use with PRT Precision

Locknut Series.

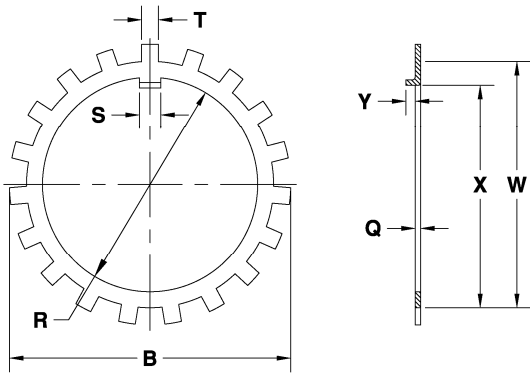

LOCKWASHER DIMENSIONS

LOCKWASHER NO.	THICKNESS		BORE		FACE DIAMETER		DIAMETER OVER TANGS NO.	TANGS WIDTH		PROJECTION		KEY BENT WIDTH		CLEARANCE		RADIUS Z	
	Q		R		W			T		Y		S		X			
	MIN.	MAX.	MIN.	MAX.	MIN.	MAX.		MIN.	MAX.	MIN.	MAX.	MIN.	MAX.	MIN.	MAX.		
PRW-00	0.034	0.042	0.406	0.421	0.625	0.640	15/16	9	0.110	0.120	0.062	0.094	0.110	0.120	0.334	0.359	1/64
PRW-01	0.034	0.042	0.484	0.499	0.719	0.734	1 7/64	9	0.110	0.120	0.062	0.094	0.110	0.120	0.412	0.437	1/64
PRW-02	0.047	0.055	0.601	0.616	0.813	0.827	1 1/4	11	0.110	0.120	0.062	0.094	0.110	0.120	0.529	0.554	1/64
PRW-03	0.047	0.055	0.679	0.694	0.938	0.953	1 13/32	11	0.110	0.120	0.062	0.094	0.110	0.120	0.607	0.632	1/64
PRW-04	0.047	0.055	0.801	0.816	1.125	1.140	2 1/16	11	0.146	0.166	0.062	0.094	0.156	0.176	0.729	0.754	1/64
PRW-05	0.050	0.058	0.989	1.009	1.281	1.296	1 51/64	13	0.146	0.166	0.093	0.125	0.156	0.176	0.909	0.939	1/64
PRW-06	0.050	0.058	1.193	1.213	1.500	1.515	2 1/16	13	0.146	0.166	0.093	0.125	0.156	0.176	1.093	1.128	1/32
PRW-065	0.050	0.058	1.333	1.353	1.813	1.827	2 21/64	15	0.146	0.166	0.093	0.125	0.156	0.176	1.221	1.256	1/32
PRW-07	0.050	0.058	1.396	1.416	1.813	1.827	2 11/32	15	0.146	0.166	0.093	0.125	0.156	0.176	1.296	1.331	1/32
PRW-08	0.059	0.067	1.583	1.603	2.000	2.030	2 37/64	15	0.204	0.234	0.093	0.125	0.250	0.290	1.475	1.510	1/32
PRW-09	0.059	0.067	1.792	1.817	2.281	2.311	2 13/16	17	0.204	0.234	0.125	0.156	0.250	0.290	1.684	1.724	1/32
PRW-10	0.059	0.067	1.992	2.017	2.438	2.468	3 1/32	17	0.204	0.234	0.125	0.156	0.250	0.290	1.884	1.924	1/32
PRW-11	0.059	0.067	2.182	2.207	2.656	2.686	3 3/16	17	0.204	0.234	0.125	0.156	0.250	0.290	2.069	2.109	1/32
PRW-12	0.070	0.078	2.400	2.425	2.844	2.874	3 7/16	17	0.204	0.234	0.125	0.156	0.250	0.290	2.267	2.307	3/64
PRW-13	0.070	0.078	2.588	2.613	3.063	3.093	3 43/64	19	0.204	0.234	0.125	0.156	0.250	0.290	2.455	2.495	3/64
PRW-14	0.070	0.078	2.791	2.816	3.313	3.343	3 29/32	19	0.204	0.234	0.187	0.250	0.250	0.290	2.658	2.698	3/64
PRW-15	0.083	0.091	2.973	3.003	3.563	3.593	4 5/32	19	0.298	0.328	0.187	0.250	0.250	0.290	2.831	2.867	3/64
PRW-16	0.083	0.091	3.177	3.207	3.844	3.874	4 1/2	19	0.298	0.328	0.187	0.250	0.313	0.353	3.035	3.080	3/64
PRW-17	0.083	0.091	3.395	3.425	4.031	4.061	4 25/32	19	0.298	0.328	0.187	0.250	0.313	0.353	3.253	3.298	3/64
PRW-18	0.111	0.119	3.582	3.612	4.281	4.326	5 5/64	19	0.298	0.328	0.187	0.250	0.313	0.353	3.418	3.463	3/64
PRW-19	0.111	0.119	3.800	3.830	4.563	4.607	5 23/64	19	0.298	0.328	0.187	0.250	0.313	0.353	3.636	3.681	3/64
PRW-20	0.111	0.119	3.988	4.018	4.813	4.858	5 5/8	19	0.298	0.328	0.250	0.313	0.313	0.353	3.809	3.859	3/64
PRW-21	0.111	0.119	4.192	4.222	5.000	5.045	5 27/32	19	0.360	0.390	0.250	0.313	0.313	0.353	4.013	4.063	3/64
PRW-22	0.125	0.135	4.395	4.425	5.281	5.326	6 9/64	19	0.360	0.390	0.250	0.313	0.313	0.353	4.185	4.235	3/64
PRW-24	0.145	0.155	4.801	4.831	5.688	5.733	6 45/64	19	0.360	0.390	0.250	0.313	0.313	0.353	4.591	4.641	3/64
PRW-26	0.145	0.155	5.191	5.226	6.188	6.233	7 5/16	19	0.480	0.520	0.250	0.313	0.375	0.435	4.961	5.016	1/16
PRW-28	0.145	0.155	5.582	5.617	6.531	6.576	7 5/8	19	0.480	0.520	0.250	0.313	0.500	0.590	5.352	5.407	1/16
PRW-30	0.180	0.195	5.983	6.018	7.063	7.123	8 9/32	19	0.480	0.520	0.312	0.375	0.500	0.590	5.722	5.777	1/16
PRW-32	0.180	0.195	6.389	6.424	7.438	7.498	8 43/64	19	0.480	0.520	0.312	0.375	0.500	0.590	6.128	6.183	1/16
PRW-34	0.180	0.195	6.764	6.799	8.031	8.091	9 19/64	19	0.480	0.520	0.312	0.375	0.625	0.715	6.503	6.558	1/16
PRW-36	0.180	0.195	7.171	7.206	8.375	8.435	9 21/32	19	0.605	0.645	0.312	0.375	0.625	0.715	6.910	6.965	1/16
PRW-38	0.180	0.195	7.577	7.612	8.781	8.841	10 3/32	19	0.605	0.645	0.312	0.375	0.625	0.715	7.316	7.371	1/16
PRW-40	0.180	0.195	7.982	8.017	9.156	9.216	10 11/16	19	0.605	0.645	0.312	0.375	0.750	0.840	7.721	7.776	1/16

LOCKWASHER DIMENSIONS

LOCKWASHER NO.	THICKNESS		BORE		FACE DIAMETER		DIAMETER OVER TANGS NO.	TANGS WIDTH		PROJECTION		KEY BENT WIDTH		CLEARANCE		RADIUS Z	
	Q		R		W			T		Y		S		X			
	MIN.	MAX.	MIN.	MAX.	MIN.	MAX.		MIN.	MAX.	MIN.	MAX.	MIN.	MAX.	MIN.	MAX.		
PRWT-00	0.034	0.042	0.406	0.421	0.531	0.551	57/64	9	0.084	0.104	0.062	0.094	0.110	0.120	0.333	0.353	1/64
PRWT-01	0.034	0.042	0.484	0.499	0.625	0.645	63/64	9	0.084	0.104	0.062	0.094	0.110	0.120	0.411	0.431	1/64
PRWT-02	0.034	0.042	0.601	0.616	0.750	0.770	1 11/64	11	0.084	0.104	0.062	0.094	0.110	0.120	0.513	0.533	1/64
PRWT-03	0.034	0.042	0.679	0.694	0.875	0.895	1 9/32	11	0.084	0.104	0.062	0.094	0.110	0.120	0.591	0.611	1/64
PRWT-04	0.034	0.042	0.801	0.816	1.000	1.020	1 7/16	11	0.146	0.166	0.062	0.094	0.156	0.176	0.724	0.744	1/64
PRWT-05	0.042	0.050	0.989	1.009	1.188	1.208	1 41/64	13	0.146	0.166	0.093	0.125	0.156	0.176	0.880	0.900	1/64
PRWT-06	0.042	0.050	1.193	1.213	1.438	1.458	1 61/64	13	0.146	0.166	0.093	0.125	0.156	0.176	1.084	1.104	1/32
PRWT-07	0.042	0.050	1.396	1.416	1.656	1.676	2 11/64	15	0.146	0.166	0.093	0.125	0.156	0.176	1.287	1.307	1/32
PRWT-08	0.054	0.064	1.583	1.603	1.844	1.864	2 21/64	15	0.204	0.234	0.093	0.125	0.280	0.300	1.474	1.494	1/32
PRWT-09	0.054	0.064	1.792	1.817	2.062	2.082	2 19/32	17	0.204	0.234	0.125	0.156	0.280	0.300	1.693	1.713	1/32
PRWT-10	0.054	0.064	1.992	2.017	2.250	2.270	2 25/32	17	0.204	0.234	0.125	0.156	0.280	0.300	1.880	1.900	1/32
PRWT-11	0.054	0.064	2.182	2.207	2.500	2.520	3 1/16	17	0.204	0.234	0.125	0.156	0.280	0.300	2.067	2.087	1/32
PRWT-12	0.054	0.064	2.400	2.425	2.688	2.708	3 9/32	17	0.204	0.234	0.125	0.156	0.280	0.300	2.255	2.275	3/64
PRWT-13	0.054	0.064	2.588	2.613	2.875	2.895	3 15/32	19	0.204	0.234	0.125	0.156	0.280	0.300	2.443	2.463	3/64
PRWT-14	0.054	0.064	2.791	2.816	3.094	3.114	3 11/16	19	0.204	0.234	0.187	0.250	0.280	0.300	2.631	2.651	3/64
PRWT-15	0.054	0.064	2.973	3.003	3.375	3.395	4 1/32	19	0.297	0.327	0.187	0.250	0.280	0.300	2.813	2.833	3/64
PRWT-16	0.054	0.064	3.177	3.207	3.594	3.614	4 1/4	19	0.297	0.327	0.187	0.250	0.340	0.360	3.017	3.037	3/64
PRWT-17	0.054	0.064	3.395	3.425	3.812	3.832	4 15/32	19	0.297	0.327	0.187	0.250	0.340	0.360	3.220	3.240	3/64
PRWT-18	0.054	0.064	3.582	3.612	4.000	4.020	4 21/32	19	0.297	0.327	0.187	0.250	0.340	0.360	3.380	3.400	3/64



LOCKWASHERS

TW-000 SERIES

LOCKWASHER DIMENSIONS

For use with tapered roller bearings

Opposite tab bend

Heavy Duty

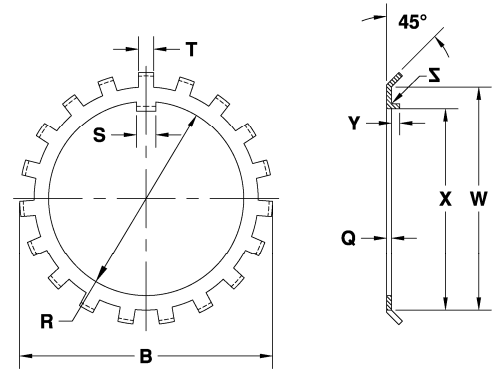

LOCKWASHER DIMENSIONS

LOCKWASHER NO.	THICKNESS		BORE		FACE DIAMETER		DIAMETER OVER TANGS		TANGS WIDTH		PROJECTION		KEY BENT WIDTH		CLEARANCE		RADIUS Z
	Q		R		W		B		T		Y		S		X		
	MIN.	MAX.	MIN.	MAX.	MIN.	MAX.	+1/16 - 0		MIN.	MAX.	MIN.	MAX.	MIN.	MAX.	MIN.	MAX.	
TW-100	0.032	0.038	0.406	0.421	0.625	0.640	57/64	9	0.110	0.120	0.062	0.094	0.110	0.120	0.334	0.359	1/64
TW-101	0.032	0.038	0.484	0.499	0.719	0.734	1 1/32	9	0.110	0.120	0.062	0.094	0.110	0.120	0.412	0.437	1/64
TW-102	0.048	0.054	0.601	0.616	0.813	0.828	1 5/32	11	0.110	0.120	0.062	0.094	0.110	0.120	0.513	0.538	1/64
TW-103	0.048	0.054	0.679	0.694	0.938	0.953	1 11/32	11	0.110	0.120	0.062	0.094	0.110	0.120	0.591	0.616	1/64
TW-104	0.048	0.054	0.801	0.816	1.125	1.140	1 9/16	11	0.146	0.166	0.062	0.094	0.156	0.176	0.713	0.738	1/64
TW-105	0.052	0.058	0.989	1.009	1.281	1.296	1 45/64	13	0.146	0.166	0.093	0.125	0.156	0.176	0.897	0.927	1/64
TW-106	0.052	0.058	1.193	1.213	1.500	1.515	1 61/64	13	0.146	0.166	0.093	0.125	0.156	0.176	1.081	1.116	1/32
TW-065	0.052	0.058	1.333	1.353	1.813	1.828	2 15/64	15	0.146	0.166	0.093	0.125	0.156	0.176	1.221	1.256	1/32
TW-107	0.052	0.058	1.396	1.416	1.813	1.828	2 1/4	15	0.146	0.166	0.093	0.125	0.156	0.176	1.284	1.319	1/32
TW-108	0.062	0.070	1.583	1.603	2.000	2.030	2 31/64	15	0.204	0.234	0.093	0.125	0.250	0.290	1.461	1.196	1/32
TW-109	0.062	0.070	1.792	1.817	2.281	2.311	2 23/32	17	0.204	0.234	0.125	0.156	0.250	0.290	1.670	1.710	1/32
TW-110	0.062	0.070	1.992	2.017	2.438	2.468	2 59/64	17	0.204	0.234	0.125	0.156	0.250	0.290	1.870	1.910	1/32
TW-111	0.062	0.070	2.182	2.207	2.656	2.686	3 3/32	17	0.204	0.234	0.125	0.156	0.250	0.290	2.060	2.100	1/32
TW-112	0.072	0.080	2.400	2.425	2.844	2.874	3 21/64	17	0.204	0.234	0.125	0.156	0.250	0.290	2.248	2.288	3/64
TW-113	0.072	0.080	2.588	2.613	3.063	3.093	3 9/16	19	0.204	0.234	0.125	0.156	0.250	0.290	2.436	2.476	3/64
TW-114	0.072	0.080	2.791	2.816	3.313	3.343	3 13/16	19	0.204	0.234	0.187	0.250	0.250	0.290	2.639	2.679	3/64
TW-115	0.085	0.095	2.973	3.003	3.563	3.593	4 3/64	19	0.298	0.328	0.187	0.250	0.250	0.290	2.808	2.853	3/64
TW-116	0.085	0.095	3.177	3.207	3.844	3.874	4 25/64	19	0.298	0.328	0.187	0.250	0.313	0.353	3.012	3.057	3/64
TW-117	0.085	0.095	3.395	3.425	4.031	4.061	4 5/8	19	0.298	0.328	0.187	0.250	0.313	0.353	3.230	3.275	3/64
TW-118	0.115	0.125	3.582	3.612	4.281	4.326	4 61/64	19	0.298	0.328	0.187	0.250	0.313	0.353	3.387	3.432	3/64
TW-119	0.115	0.125	3.800	3.830	4.563	4.608	5 15/64	19	0.298	0.328	0.187	0.250	0.313	0.353	3.605	3.650	3/64
TW-120	0.115	0.125	3.988	4.018	4.813	4.858	5 31/64	19	0.298	0.328	0.250	0.313	0.313	0.353	3.778	3.828	3/64
TW-121	0.115	0.125	4.192	4.222	5.000	5.045	5 45/64	19	0.360	0.390	0.250	0.313	0.313	0.353	3.982	4.032	3/64
TW-122	0.130	0.140	4.395	4.425	5.281	5.326	6	19	0.360	0.390	0.250	0.313	0.313	0.353	4.170	4.220	3/64
TW-124	0.155	0.165	4.801	4.831	5.688	5.733	6 17/32	19	0.360	0.390	0.250	0.313	0.313	0.353	4.551	4.601	3/64
TW-126	0.155	0.165	5.191	5.226	6.188	6.233	7 3/64	19	0.480	0.520	0.250	0.313	0.375	0.435	4.921	4.976	1/16
TW-128	0.155	0.165	5.582	5.617	6.531	6.576	7 7/16	19	0.480	0.520	0.250	0.313	0.500	0.590	5.312	5.367	1/16
TW-130	0.193	0.205	5.983	6.018	7.063	7.123	8 1/16	19	0.480	0.520	0.312	0.375	0.500	0.590	5.675	5.730	1/16
TW-132	0.193	0.205	6.389	6.424	7.438	7.498	8 29/64	19	0.480	0.520	0.312	0.375	0.500	0.590	6.081	6.136	1/16
TW-134	0.193	0.205	6.764	6.799	8.031	8.091	9 5/64	19	0.480	0.520	0.312	0.375	0.625	0.715	6.456	6.511	1/16
TW-136	0.193	0.205	7.171	7.206	8.375	8.435	9 7/16	19	0.605	0.645	0.312	0.375	0.625	0.715	6.863	6.918	1/16
TW-138	0.193	0.205	7.577	7.612	8.781	8.841	9 55/64	19	0.605	0.645	0.312	0.375	0.625	0.715	7.269	7.324	1/16
TW-140	0.193	0.205	7.982	8.017	9.156	9.216	10 13/32	19	0.605	0.645	0.312	0.375	0.750	0.840	7.674	7.729	1/16



LOCKWASHERS

WTH-00 & WIN-00 SERIES

LOCKWASHER DIMENSIONS

WTH for use with NTH Locknut Series
WIN for use with NIN Locknut Series

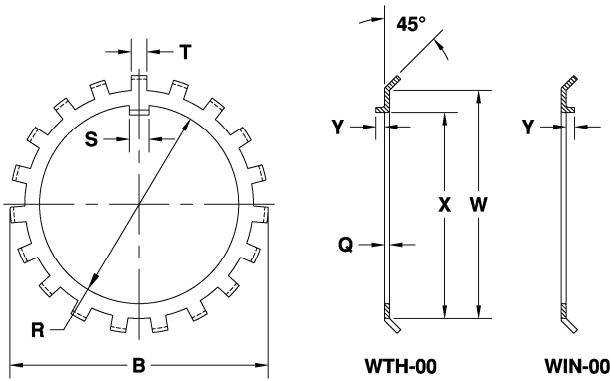

WTH-00 LOCKWASHER DIMENSIONS

LOCKWASHER NO.	THICKNESS Q		BORE R		FACE DIAMETER W		DIAMETER OVER TANGS B		TANGS NO.	TANGS WIDTH T		PROJECTION Y		KEY BENT WIDTH S		CLEARANCE X		RADIUS Z
	MIN.	MAX.	MIN.	MAX.	MIN.	MAX.	+0 - 1/16	MIN.		MAX.	MIN.	MAX.	MIN.	MAX.	MIN.	MAX.		
	WTH-00	0.036	0.044	0.406	0.421	0.531	0.551	53/64		9	0.084	0.104	0.062	0.094	0.110	0.120	0.333	
WTH-01	0.036	0.044	0.484	0.499	0.625	0.645	59/64	9	0.084	0.104	0.062	0.094	0.110	0.120	0.411	0.431	1/64	
WTH-02	0.036	0.044	0.601	0.616	0.750	0.770	1 3/32	11	0.084	0.104	0.062	0.094	0.110	0.120	0.513	0.533	1/64	
WTH-03	0.036	0.044	0.679	0.694	0.875	0.895	1 13/64	11	0.084	0.104	0.062	0.094	0.110	0.120	0.591	0.611	1/64	
WTH-04	0.036	0.044	0.801	0.816	1.000	1.020	1 3/8	11	0.146	0.166	0.062	0.094	0.156	0.176	0.724	0.744	1/64	
WTH-05	0.046	0.054	0.989	1.009	1.188	1.208	1 9/16	13	0.146	0.166	0.093	0.125	0.156	0.176	0.880	0.900	1/64	
WTH-06	0.046	0.054	1.193	1.213	1.438	1.458	1 55/64	13	0.146	0.166	0.093	0.125	0.156	0.176	1.084	1.104	1/32	
WTH-07	0.046	0.054	1.396	1.416	1.656	1.676	2 5/64	15	0.146	0.166	0.093	0.125	0.156	0.176	1.287	1.307	1/32	
WTH-08	0.058	0.068	1.583	1.603	1.844	1.864	2 1/4	15	0.204	0.234	0.093	0.125	0.280	0.300	1.474	1.494	1/32	
WTH-09	0.058	0.068	1.792	1.817	2.062	2.082	2 1/2	17	0.204	0.234	0.125	0.156	0.280	0.300	1.693	1.713	1/32	
WTH-10	0.058	0.068	1.992	2.017	2.250	2.270	2 11/16	17	0.204	0.234	0.125	0.156	0.280	0.300	1.880	1.900	1/32	
WTH-11	0.058	0.068	2.182	2.207	2.500	2.520	2 61/64	17	0.204	0.234	0.125	0.156	0.280	0.300	2.067	2.087	1/32	
WTH-12	0.058	0.068	2.400	2.425	2.688	2.708	3 3/16	17	0.204	0.234	0.125	0.156	0.280	0.300	2.255	2.275	3/64	
WTH-13	0.058	0.068	2.588	2.613	2.875	2.895	3 3/8	19	0.204	0.234	0.125	0.156	0.280	0.300	2.443	2.463	3/64	
WTH-14	0.058	0.068	2.791	2.816	3.094	3.114	3 19/32	19	0.204	0.234	0.187	0.250	0.280	0.300	2.631	2.651	3/64	
WTH-15	0.058	0.068	2.973	3.003	3.375	3.395	3 59/64	19	0.297	0.327	0.187	0.250	0.280	0.300	2.813	2.833	3/64	
WTH-16	0.058	0.068	3.177	3.207	3.594	3.614	4 9/64	19	0.297	0.327	0.187	0.250	0.340	0.360	3.017	3.037	3/64	
WTH-17	0.058	0.068	3.395	3.425	3.812	3.832	4 23/64	19	0.297	0.327	0.187	0.250	0.340	0.360	3.220	3.240	3/64	
WTH-18	0.058	0.068	3.582	3.612	4.000	4.020	4 35/64	19	0.297	0.327	0.187	0.250	0.340	0.360	3.380	3.400	3/64	

WIN-00 LOCKWASHER DIMENSIONS

LOCKWASHER NO.	THICKNESS Q		BORE R		FACE DIAMETER W		DIAMETER OVER TANGS B		TANGS NO.	TANGS WIDTH T		PROJECTION Y		KEY BENT WIDTH S		CLEARANCE X		RADIUS Z
	MIN.	MAX.	MIN.	MAX.	MIN.	MAX.	+0 - 1/16	MIN.		MAX.	MIN.	MAX.	MIN.	MAX.	MIN.	MAX.		
	WIN-01	0.046	0.054	0.797	0.828	1.188	1.203	1 9/16		9	0.178	0.198	0.125	0.156	0.168	0.188	0.687	
WIN-02	0.046	0.054	0.922	0.953	1.313	1.328	1 11/16	9	0.178	0.198	0.125	0.156	0.168	0.188	0.812	0.837	1/64	
WIN-03	0.046	0.054	1.047	1.078	1.438	1.453	1 13/16	11	0.178	0.198	0.125	0.156	0.168	0.188	0.937	0.962	1/64	
WIN-04	0.046	0.054	1.172	1.203	1.563	1.578	2	11	0.178	0.198	0.125	0.156	0.168	0.188	1.062	1.087	1/32	
WIN-05	0.046	0.054	1.297	1.328	1.688	1.703	2 1/8	11	0.178	0.198	0.125	0.156	0.168	0.188	1.187	1.212	1/32	
WIN-06	0.046	0.054	1.422	1.453	1.938	1.953	2 3/8	13	0.178	0.198	0.125	0.156	0.168	0.188	1.312	1.337	1/32	
WIN-07	0.046	0.054	1.547	1.578	1.938	1.953	2 3/8	13	0.178	0.198	0.125	0.156	0.168	0.188	1.437	1.462	1/32	
WIN-08	0.058	0.068	1.672	1.703	2.188	2.203	2 5/8	13	0.240	0.260	0.125	0.156	0.240	0.260	1.562	1.587	1/32	
WIN-09	0.058	0.068	1.797	1.828	2.313	2.328	2 3/4	15	0.240	0.260	0.125	0.156	0.240	0.260	1.687	1.712	1/32	
WIN-10	0.058	0.068	1.922	1.953	2.438	2.453	2 7/8	15	0.240	0.260	0.125	0.156	0.240	0.260	1.812	1.837	1/32	
WIN-11	0.058	0.068	2.047	2.078	2.688	2.703	3 1/8	15	0.240	0.260	0.125	0.156	0.240	0.260	1.937	1.962	1/32	
WIN-12	0.058	0.068	2.297	2.328	2.875	2.890	3 7/16	17	0.240	0.260	0.187	0.218	0.240	0.260	2.187	2.212	3/64	
WIN-13	0.058	0.068	2.547	2.578	3.125	3.140	3 11/16	17	0.240	0.260	0.187	0.218	0.240	0.260	2.437	2.462	3/64	
WIN-14	0.058	0.068	2.797	2.828	3.375	3.390	3 15/16	17	0.240	0.260	0.187	0.218	0.240	0.260	2.687	2.712	3/64	

LOCKWASHERS



MB-00 SERIES

LOCKWASHER DIMENSIONS

Metric

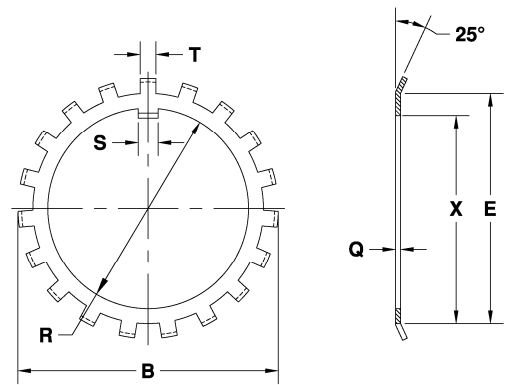

MB-00 LOCKWASHER DIMENSIONS

LOCKWASHER NO.	BORE		FACE DIAMETER		DIAMETER OVER TANGS		KEY WIDTH	INSIDE DIMENSION	MATERIAL THICKNESS	TANG WIDTH	NO. OF TANGS
	R NOM.	E MIN.	E MIN.	B MAX.	S MAX.	X NOM.	Q NOM.	T MAX.			
MB-0	0.394	0.532	0.532	0.827	0.118	0.335	0.039	0.118	9		
MB-1	0.472	0.669	0.669	0.984	0.118	0.413	0.039	0.118	11		
MB-2	0.591	0.827	0.827	1.102	0.157	0.532	0.039	0.157	11		
MB-3	0.669	0.945	0.945	1.260	0.157	0.610	0.039	0.157	11		
MB-4	0.787	1.024	1.024	1.417	0.157	0.728	0.039	0.157	11		
MB-4.4	0.866	1.102	1.102	1.496	0.157	0.807	0.039	0.157	11		
MB-5	0.984	1.260	1.260	1.654	0.197	0.906	0.049	0.197	13		
MB-5.6	1.102	1.417	1.417	1.811	0.197	1.024	0.049	0.197	13		
MB-6	1.181	1.496	1.496	1.929	0.197	1.083	0.049	0.197	13		
MB-6.4	1.260	1.575	1.575	2.047	0.197	1.161	0.049	0.197	15		
MB-7	1.378	1.732	1.732	2.244	0.236	1.280	0.049	0.197	13		
MB-8	1.575	1.968	1.968	2.241	0.236	1.476	0.049	0.236	13		
MB-9	1.772	2.205	2.205	2.717	0.236	1.673	0.049	0.236	13		
MB-10	1.968	2.402	2.402	2.913	0.236	1.870	0.049	0.236	13		
MB-11	2.165	2.638	2.638	3.189	0.315	2.067	0.059	0.276	17		
MB-12	2.362	2.874	2.874	3.386	0.315	2.264	0.059	0.276	17		
MB-13	2.559	3.110	3.110	3.622	0.315	2.461	0.059	0.276	17		
MB-14	2.756	3.346	3.346	3.858	0.315	2.618	0.059	0.315	17		
MB-15	2.953	3.543	3.543	4.094	0.315	2.815	0.059	0.315	17		
MB-16	3.150	3.740	3.740	4.409	0.394	3.012	0.071	0.315	17		
MB-17	3.346	4.016	4.016	4.685	0.394	3.209	0.071	0.315	17		
MB-18	3.543	4.252	4.252	4.961	0.394	3.406	0.071	0.394	17		
MB-19	3.740	4.449	4.449	5.236	0.394	3.602	0.071	0.394	17		
MB-20	3.937	4.724	4.724	5.591	0.472	3.799	0.071	0.394	17		
MB-21	4.134	4.961	4.961	5.709	0.472	3.957	0.071	0.472	17		
MB-22	4.331	5.236	5.236	6.063	0.472	4.154	0.071	0.472	17		
MB-23	4.528	5.394	5.394	6.260	0.472	4.350	0.079	0.472	17		
MB-24	4.724	5.433	5.433	6.457	0.551	4.528	0.079	0.472	17		
MB-25	4.921	5.827	5.827	6.693	0.551	4.724	0.079	0.472	17		
MB-26	5.118	5.866	5.866	6.890	0.551	4.921	0.079	0.472	17		
MB-27	5.315	6.299	6.299	7.283	0.551	5.118	0.079	0.551	17		
MB-28	5.512	6.299	6.299	7.559	0.630	5.315	0.079	0.551	17		
MB-29	5.709	6.732	6.732	7.953	0.630	5.512	0.079	0.551	17		
MB-30	5.906	6.732	6.732	8.071	0.630	5.709	0.079	0.551	17		
MB-31	6.102	7.165	7.165	8.346	0.630	5.807	0.098	0.630	19		
MB-32	6.299	7.165	7.165	8.543	0.709	6.063	0.098	0.630	19		
MB-33	6.496	7.598	7.598	8.740	0.709	6.201	0.098	0.630	19		
MB-34	6.693	7.598	7.598	9.134	0.709	6.457	0.098	0.630	19		
MB-36	7.087	7.992	7.992	9.528	0.787	6.850	0.098	0.709	19		
MB-38	7.480	8.425	8.425	9.921	0.787	7.244	0.098	0.709	19		
MB-40	7.874	8.898	8.898	10.315	0.787	7.638	0.098	0.709	19		
MB-44	8.661	9.843	9.843	11.496	0.945	8.368	0.118	0.787	19		
MB-48	9.449	10.630	10.630	12.283	0.945	9.173	0.118	0.787	19		
MB-52	10.236	11.811	11.811	13.465	1.102	9.961	0.118	0.945	19		
MB-56	11.024	12.598	12.598	14.252	1.102	10.748	0.118	0.945	19		



LOCKWASHERS



Lockplate

Bearing Accessories



P-000 SERIES

LOCKPLATE DIMENSIONS

For use with SNP-00 and SNP-3100 series adapters

**INCLUDES 2 CAP SCREWS
AND 1 LOCKWIRE**

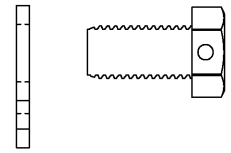
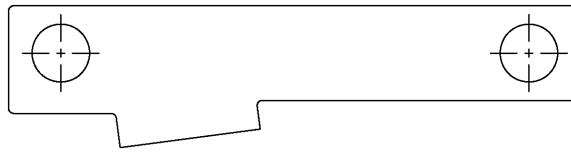

LOCKPLATE DIMENSIONS

LOCKPLATE NO.	CAPSCREW SIZE J ₂	LOCKNUT NO.
P-48	5/16 -- 18 x 5/8	N-048
P-52	5/16 -- 18 x 5/8	N-052
P-56	5/16 -- 18 x 5/8	N-056
P-60	3/8 -- 16 x 3/4	N-060
P-64	3/8 -- 16 x 3/4	N-064
P-68	3/8 -- 16 x 3/4	N-068
P-72	3/8 -- 16 x 3/4	N-072
P-76	1/2 -- 13 x 7/8	N-076
P-80	1/2 -- 13 x 7/8	N-080
P-84	1/2 -- 13 x 7/8	N-084
P-88	5/8 -- 11 x 1	N-088
P-92	5/8 -- 11 x 1	N-092
P-96	5/8 -- 11 x 1 1/4	N-096
P-500	5/8 -- 11 x 1 1/4	N-500
P-530	5/8 -- 11 x 1 1/4	N-530
P-560	5/8 -- 11 x 1 1/4	N-560
P-600	5/8 -- 11 x 1 1/4	N-600
P-630	5/8 -- 11 x 1 1/4	N-630
P-670	5/8 -- 11 x 1 1/4	N-670
P-710	5/8 -- 11 x 1 1/4	N-710
P-750	5/8 -- 11 x 1 1/4	N-750
P-800	5/8 -- 11 x 1 1/4	N-800
P-850	3/4 -- 10 x 1 1/2	N-850
P-900	3/4 -- 10 x 1 1/2	N-900
P-950	3/4 -- 10 x 1 1/2	N-950

NOTES:

MS-Series Metric Clamps are also available.

LOCKPLATES





Split Pillow Blocks

Bearing Accessories

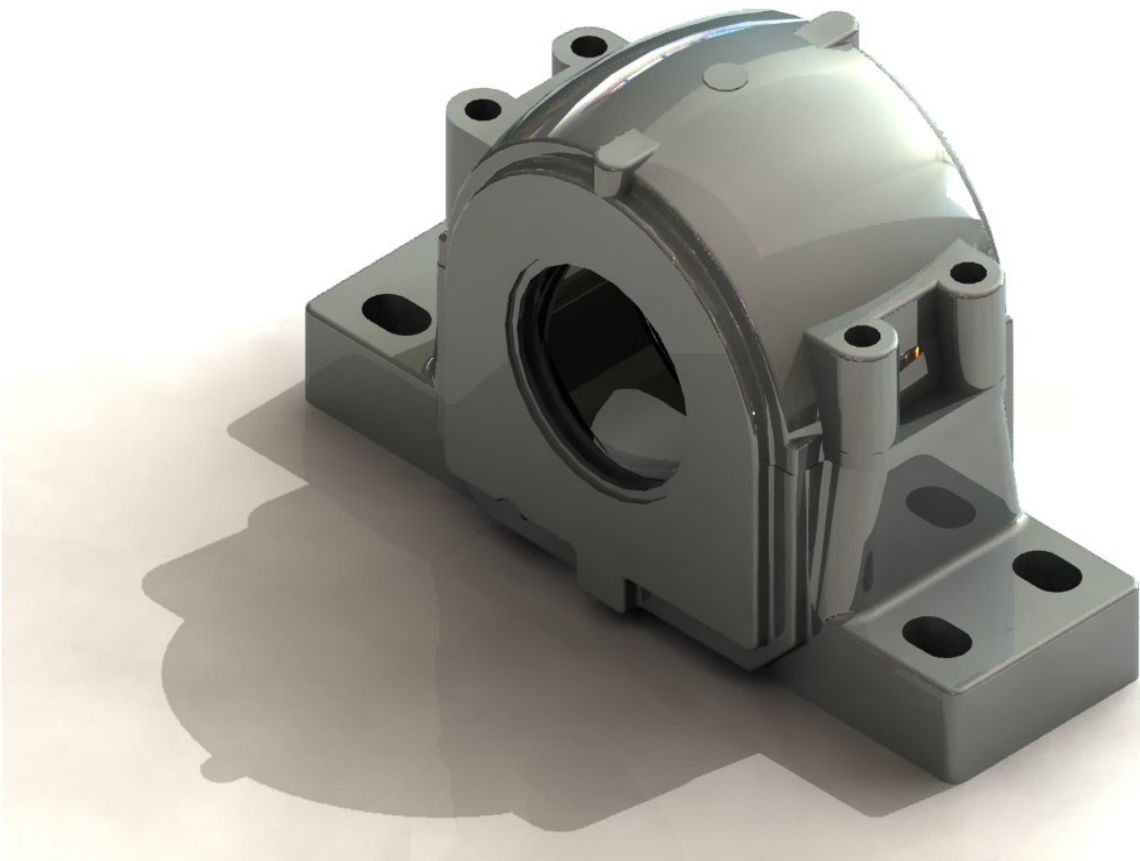

SAF 200 and 300 SERIES

CAST IRON PILLOW BLOCKS

STRAIGHT BORE MOUNTING

SAF-200 SERIES

SHAFT DIA.		PILLOW BLOCK HOUSING ONLY	STABILIZING RING 1 REQUIRED	TRIPLE SEAL		LOCKNUT NO.	LOCKWASHER NO.	COMPLETE PILLOW BLOCK NO.	APP. WT. (LB.)
S-2 IN.	S-3 IN.			S-2 SHAFT 1 REQUIRED	S-3 SHAFT 1 REQUIRED				
2 3/8	1 7/8	SAF210*	SR-10-0	LER35	LER23	N10	W10	SAF22210	12
2 9/16	2 1/16	SAF211*	SR-11-0	LER40	LER27	N11	W11	SAF22211	14
3 1/16	2 7/16	SAF213*	SR-13-0	LER55	LER37	N13	W13	SAF22213	21
3 7/16	2 13/16	SAF215*	SR-15-0	LER79	LER456	AN15	W15	SAF22215	24
3 7/16	2 13/16	FSAF215	SR-15-0	LER79	LER456	AN15	W15	SAF22215	24
3 5/8	3	SAF216*	SR-16-13	LER82	LER54	AN16	W16	SAF22216	35
3 5/8	3	FSAF216	SR-16-13	LER82	LER54	AN16	W16	SAF22216	35
3 15/16	3 3/16	SAF 217*	SR-17-14	LER89	LER63	AN17	W17	SAF22217	43
3 15/16	3 3/16	FSAF217	SR-17-14	LER89	LER63	AN17	W17	FSAF22217	43
4 1/8	3 3/8	SAF 218*	SR-18-15	LER96	LER72	AN18	W18	SAF22218	50
4 1/8	3 3/8	FSAF218	SR-18-15	LER96	LER72	AN18	W18	FSAF22218	50
4 1/2	3 13/16	SAF220*	SR-20-17	LER118	LER106	AN20	W20	SAF22220	71
4 1/2	3 13/16	FSAF220	SR-20-17	LER118	LER106	AN20	W20	FSAF22220	71
4 7/8	4 3/16	SAF222	SR-22-19	LER121	LER113	AN22	W22	SAF22222	81
5 5/16	4 9/16	SAF224	SR-24-20	LER127	LER119	AN24	W24	SAF22224	90
5 7/8	4 15/16	SAF226	SR-26-0	LER136	LER122	AN26	W26	SAF22226	127
6 1/4	5 5/16	SAF228	SR-28-0	LER144	LER127	AN28	W28	SAF22228	149
6 5/8	5 3/4	SAF230	SR-30-0	LER151	LER134	AN30	W30	SAF22230	175
7	6 1/16	SAF232	SR-32-0	LER156	LER142	AN32	W32	SAF22232	210
7 7/16	6 7/16	SAF234	SR-34-0	LER161	LER148	AN34	W34	SAF22234	280
7 13/16	6 7/8	SAF236	SR-36-30	LER165	LER154	AN36	W36	SAF22236	305
8 3/8	7 1/4	SAF238	SR-38-32	LER171	LER160	AN38	W38	SAF22238	350
8 3/4	7 5/8	SAF240	SR-40-34	LER175	LER164	AN40	W40	SAF22240	420
9 9/16	8 5/16	SAF244	SR-44-38	LER179	LER170	N44	W44	SAF22244	590

SAF-300 SERIES

3 7/16	2 13/16	SAF315	SR-18-5	LER79	LER46	AN15	W15	SAF22315	53
3 15/16	3 3/16	SAF317*	SR-20-17	LER109	LER188	AN17	W17	SAF22317	80
3 15/16	3 3/16	FSAF317	SR-20-17	LER109	LER188	AN17	W17	FSAF22317	80
4 1/8	3 3/8	SAF318	SR-21-18	LER112	LER191	AN18	W18	SAF22318	92
4 1/2	3 13/16	SAF320	SR-24-20	LER118	LER106	AN20	W20	SAF22320	109
4 7/8	4 3/16	SAF322	SR-0-22	LER121	LER113	AN22	W22	SAF22322	145
5 5/16	4 9/16	SAF324	SR-0-24	LER127	LER119	AN24	W24	SAF22324	195
5 7/8	4 15/16	SAF326	SR-0-26	LER136	LER122	AN26	W26	SAF22326	235
6 1/4	5 5/16	SAF328	SR-0-28	LER144	LER127	AN28	W28	SAF22328	300
6 5/8	5 3/4	SAF330	SR-36-30	LER151	LER134	AN30	W30	SAF22330	335
7	6 1/16	SAF332	SR-38-32	LER156	LER142	AN32	W32	SAF22332	105
7 7/16	6 7/16	SAF334	SR-40-34	LER161	LER148	AN34	W34	SAF22334	465
7 11/16	6 7/8	SAF336	SR-0-36	LER165	LER154	AN36	W36	SAF22336	525
8 3/8	7 1/4	SAF338	SR-44-38	LER171	LER160	AN38	W38	SAF22338	635
8 3/4	7 5/8	SAF340	SR-0-40	LER175	LER164	AN40	W40	SAF22340	700

NOTES:

Triple seal rings (LER series) and stabilizing ring (SR series) are included with the pillow block.

Stabilizing ring used only for "fixed" mounting, not used for "free" mounting. Available in ductile iron as well (SAFD series)

* Pillow blocks with 2-hole mounting base, all others have 4-hole mounting base.

PILLOW BLOCKS



SAF 200 and 300 SERIES

CAST IRON PILLOW BLOCKS

STRAIGHT BORE MOUNTING

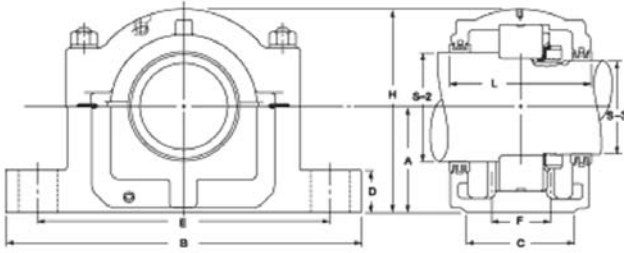

SAF-200 SERIES

PILLOW BLOCK HOUSING ONLY	A	B	C	D	E		F	H	L	BASE BOLTS REQUIRED	
					MAX.	MIN.				NO.	SIZE
SAF210	2 1/2	8 1/4	2 3/8	15/16	7	6 1/2	---	4 11/16	3 7/16	2	7/16
SAF211	2 3/4	9 5/8	2 3/4	15/16	7 7/8	7 3/8	---	5 1/32	3 3/4	2	5/8
SAF213	3	11	3 1/8	1	9 1/2	8 1/8	---	5 25/32	4 5/16	2	5/8
SAF215	3 1/4	11 1/4	3 1/8	1 1/8	9 5/8	8 5/8	---	6 3/8	4 3/4	2	5/8
FSAF215	3 1/4	11 1/4	3 1/8	1 1/8	9 5/8	8 5/8	1 7/8	6 3/8	4 3/4	4	1/2
SAF216	3 1/2	13	3 1/2	1 3/16	11	9 5/8	---	6 7/8	4 7/8	2	3/4
FSAF216	3 1/2	13	3 1/2	1 3/16	11	9 5/8	2 1/8	6 7/8	4 7/8	4	5/8
SAF217	3 3/4	13	3 1/2	1 1/4	11	9 7/8	---	7 1/4	4 7/8	2	3/4
FSAF217	3 3/4	13	3 1/2	1 1/4	11	9 7/8	2 1/8	7 1/4	4 7/8	4	5/8
SAF218	4	13 3/4	3 7/8	1 1/2	11 5/8	10 3/8	---	7 3/4	6 1/8	2	3/4
FSAF218	4	13 3/4	3 7/8	1 1/2	11 5/8	10 3/8	2 1/8	7 3/4	6 1/8	4	5/8
SAF220	4 1/2	15 1/4	4 3/8	1 3/4	13 1/8	11 5/8	---	8 11/16	5 7/8	2	7/8
FSAF220	4 1/2	15 1/4	4 3/8	1 11/16	13 1/8	11 5/8	2 3/8	8 11/16	5 7/8	4	3/4
SAF222	4 15/16	16 1/2	4 3/4	2	14 7/16	12 11/16	2 3/4	9 9/16	6 1/4	4	3/4
SAF224	5 1/4	16 1/2	4 3/4	2 1/8	14 1/2	13 1/4	2 3/4	10 1/4	7 1/4	4	3/4
SAF226	6	18 3/8	5 1/8	2 3/8	16	14 5/8	3 1/4	11 9/16	7 7/8	4	7/8
SAF228	6	20 1/8	5 7/8	2 3/8	17 1/8	16	3 3/8	11 3/4	7 5/8	4	1
SAF230	6 5/16	21 1/4	6 1/4	2 1/2	18 1/4	17	3 3/4	12 1/2	8 1/4	4	1
SAF232	6 11/16	22	6 1/4	2 5/8	19 1/4	17 3/8	3 3/4	13 5/16	8 5/8	4	1
SAF234	7 1/16	24 3/4	6 3/4	2 13/16	21 5/8	19 3/8	4 1/4	14 9/16	9 1/4	4	1
SAF236	7 1/2	26 3/4	7 1/8	3	23 5/8	20 7/8	4 5/8	15 1/2	9 11/16	4	1
SAF238	7 7/8	28	7 1/2	3 1/8	24 3/8	21 5/8	4 1/2	15 11/16	10 5/8	4	1 1/4
SAF240	8 1/4	29 1/2	8	3 3/8	25	22 1/2	5	17 3/16	10 13/16	4	1 1/4
SAF244	9 1/2	32 3/4	8 3/4	3 3/4	27 7/8	24 3/4	5 1/4	19 5/8	11 1/2	4	1 1/2

SAF-300 SERIES

SAF315	4	13 3/4	3 7/8	1 5/16	11 5/8	10 3/8	---	7 13/16	6 1/8	2	5/8
SAF317	4 1/2	15 1/4	4 3/8	1 3/4	13 1/8	11 5/8	---	8 11/16	6 5/8	2	7/8
FSAF317	4 1/2	15 1/4	4 3/8	1 3/4	13 1/8	11 5/8	2 3/8	8 11/16	6 5/8	4	3/4
SAF318	4 3/4	15 1/2	4 3/8	2	13 1/2	12	2 1/4	9 3/16	6 7/8	4	3/4
SAF320	5 1/4	16 1/2	4 3/4	2 1/8	14 1/2	13 1/4	2 3/4	10 1/4	7 1/4	4	3/4
SAF322	6	18 3/8	5 1/8	2 3/8	16	14 5/8	3 1/4	11 9/16	7 7/8	4	7/8
SAF324	6 5/16	21 1/4	6 1/4	2 1/2	18 1/4	17	3 3/4	12 1/2	8 1/4	4	1
SAF326	6 11/16	22	6 1/4	2 5/8	19 1/4	17 3/8	3 3/4	13 5/16	8 5/8	4	1
SAF328	7 1/16	24 3/4	6 3/4	2 1/4	21 5/8	19 3/8	4 1/4	14 9/16	9 1/4	4	1
SAF330	7 1/2	26 3/4	7 1/8	3	23 5/8	20 7/8	4 5/8	15 1/2	9 11/16	4	1
SAF332	7 7/8	28	7 1/2	3 1/8	24 3/8	21 5/8	4 1/2	15 11/16	10 5/8	4	1 1/4
SAF334	8 1/4	29 1/2	8	3 3/8	25	22 1/2	5	17 3/16	10 13/16	4	1 1/4
SAF336	8 7/8	31 1/4	8 1/4	3 1/2	26 5/8	24	5 1/4	18 1/2	11 1/4	4	1 1/4
SAF338	9 1/2	32 3/4	8 3/4	3 3/4	28 1/8	24 3/4	5 1/4	19 5/8	11 1/2	4	1 1/2
SAF340	9 7/8	34 1/4	9	4 3/32	29 1/2	26 1/4	5 1/2	20 3/16	12 1/4	4	1 1/2



PILLOW BLOCKS

SAF 500 and 600 SERIES

CAST IRON PILLOW BLOCKS

TAPERED BORE/ADAPTER MOUNTING

SAF-500 SERIES

SHAFT DIA. S-1 IN.	PILLOW BLOCK HOUSING ONLY	STABILIZING	TRIPLE SEAL	COMPLETE	ADAPTER NO.	APP. WT. (LB.)
		RING 1 REQUIRED	2 REQUIRED	PILLOW BLOCK NO.		
1 11/16	SAF510**	SR-10-8	LER20	SAF22510	SNW-10	12
1 15/16	SAF511**	SR-11-0	LER24	SAF22511	SNW-11	14
2 3/16	SAF513**	SR-13-0	LER29	SAF22513	SNW-13	21
2 7/16	SAF515*	SR-15-0	LER37	SAF22515	SNW-15	24
2 7/16	FSAF515	SR-15-0	LER37	FSAF22515	SNW-15	32
2 11/16	SAF516*	SR-16-13	LER44	SAF22516	SNW-16	37
2 11/16	FSAF516	SR-16-13	LER44	FSAF22516	SNW-16	37
2 15/16	SAF517*	SR-17-14	LER53	SAF22517	SNW-17	40
2 15/16	FSAF517	SR-17-14	LER53	FSAF22517	SNW-17	40
3 3/16	SAF518*	SR-18-15	LER69	SAF22518	SNW-18	49
3 3/16	FSAF518	SR-18-15	LER69	FSAF22518	SNW-18	49
3 7/16	SAF520*	SR-20-17	LER102	SAF22520	SNW-20	65
3 7/16	FSAF520	SR-20-17	LER102	FSAF22520	SNW-20	65
3 15/16	SAF522	SR-22-19	LER109	SAF22522	SNW-22	81
4 3/16	SAF524	SR-24-20	LER113	SAF22524	SNW-24	94
4 7/16	SAF526	SR-26-0	LER117	SAF22526	SNW-26	137
4 15/16	SAF528	SR-28-0	LER122	SAF22528	SNW-28	159
5 3/16	SAF530	SR-30-0	LER125	SAF22530	SNW-30	189
5 7/16	SAF532	SR-32-0	LER130	SAF22532	SNW-32	225
5 15/16	SAF534	SR-34-0	LER140	SAF22534	SNW-34	300
6 7/16	SAF536	SR-36-30	LER148	SAF22536	SNW-36	330
6 15/16	SAF538	SR-38-32	LER155	SAF22538	SNW-38	375
7 3/16	SAF540	SR-40-34	LER159	SAF22540	SNW-40	445
7 15/16	SAF544	SR-44-38	LER167	SAF22544	SNW-44	615

SAF-600 SERIES

2 7/16	SAF615	SR-18-15	LER37	SAF22615	SNW-115	55
2 15/16	SAF617*	SR-20-17	LER184	SAF22617	SNW-117	81
2 15/16	FSAF617	SR-20-17	LER184	FSAF22617	SNW-117	81
3 3/16	SAF618	SR-21-18	LER188	SAF22618	SNW-118	90
3 7/16	SAF620	SR-24-20	LER102	SAF22620	SNW-120	113
3 15/16	SAF622	SR-0-22	LER109	SAF22622	SNW-122	151
4 3/16	SAF624	SR-0-24	LER113	SAF22624	SNW-124	201
4 7/16	SAF626	SR-0-26	LER117	SAF22626	SNW-126	245
4 15/16	SAF628	SR-0-28	LER122	SAF22628	SNW-128	310
5 3/16	SAF630	SR-36-30	LER125	SAF22630	SNW-130	350
5 7/16	SAF632	SR-38-32	LER130	SAF22632	SNW-132	420
5 15/16	SAF634	SR-40-34	LER140	SAF22634	SNW-134	485
6 7/16	SAF636	SR-0-36	LER148	SAF22636	SNW-136	545
6 15/16	SAF638	SR-44-38	LER155	SAF22638	SNW-138	665
7 3/16	SAF640	SR-0-40	LER159	SAF22640	SNW-140	725

NOTES:

Triple seal rings (LER series) and stabilizing ring (SR series) are included with the pillow block.

Stabilizing ring used only for "fixed" mounting, not used for "free" mounting.

Available in ductile iron as well (SAFD series)

* Pillow blocks with 2-hole mounting base, all others have 4-hole mounting base.

** 2-Bolt cap and 2-bolt base.

PILLOW BLOCKS



SAF 500 and 600 SERIES

CAST IRON PILLOW BLOCKS TAPERED BORE/ADAPTER MOUNTING

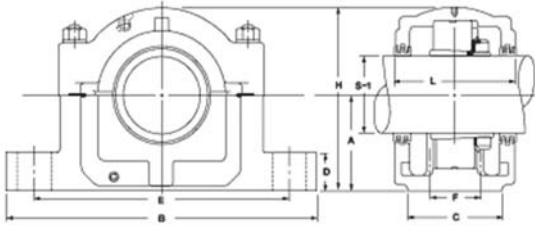

SAF-500 SERIES

PILLOW BLOCK HOUSING ONLY	A	B	C	D	E		F	H	L	BASE BOLTS REQUIRED	
					MAX.	MIN.				NO.	SIZE
SAF510**	2 1/2	8 1/4	2 3/8	15/16	7	6 1/2	--	4 11/16	3 7/16	2	7/16
SAF511**	2 3/4	9 5/8	2 3/4	15/16	7 7/8	7 3/8	--	5 1/32	3 3/4	2	5/8
SAF513**	3	11	3 1/8	1	9 1/2	8 1/8	--	5 25/32	4 5/16	2	5/8
SAF515*	3 1/4	11 1/4	3 1/8	1 1/8	9 5/8	8 5/8	--	6 3/8	4 3/4	2	5/8
FSAF515	3 1/4	11 1/4	3 1/8	1 1/8	9 5/8	8 5/8	1 7/8	6 3/8	4 3/4	4	1/2
SAF516*	3 1/2	13	3 1/2	1 3/16	11	9 5/8	--	6 7/8	4 7/8	2	3/4
FSAF516	3 1/2	13	3 1/2	1 3/16	11	9 5/8	2 1/8	6 7/8	4 7/8	4	5/8
SAF517*	3 3/4	13	3 1/2	1 1/4	11	9 7/8	--	7 1/4	4 7/8	2	3/4
FSAF517	3 3/4	13	3 1/2	1 1/4	11	9 7/8	2 1/8	7 1/4	4 7/8	4	5/8
SAF518*	4	13 3/4	3 7/8	1 1/2	11 5/8	10 3/8	--	7 3/4	6 1/8	2	3/4
FSAF518	4	13 3/4	3 7/8	1 1/2	11 5/8	10 3/8	2 1/8	7 3/4	6 1/8	4	5/8
SAF520*	4 1/2	15 1/4	4 3/8	1 3/4	13 1/8	11 5/8	--	8 11/16	5 7/8	2	7/8
FSAF520	4 1/2	15 1/4	4 3/8	1 11/16	13 1/8	11 5/8	2 3/8	8 11/16	5 7/8	4	3/4
SAF522	4 15/16	16 1/2	4 3/4	2	14 7/16	12 11/16	2 3/4	9 9/16	6 1/4	4	3/4
SAF524	5 1/4	16 1/2	4 3/4	2 1/8	14 1/2	13 1/4	2 3/4	10 1/4	7 1/4	4	3/4
SAF526	6	18 3/8	5 1/8	2 3/8	16	14 5/8	3 1/4	11 9/16	7 7/8	4	7/8
SAF528	6	20 1/8	5 7/8	2 3/8	17 1/8	16	3 3/8	11 3/4	7 5/8	4	1
SAF530	6 5/16	21 1/4	6 1/4	2 1/2	18 1/4	17	3 3/4	12 1/2	8 1/4	4	1
SAF532	6 11/16	22	6 1/4	2 5/8	19 1/4	17 3/8	3 3/4	13 5/16	8 5/8	4	1
SAF534	7 1/16	24 3/4	6 3/4	2 13/16	21 5/8	19 3/8	4 1/4	14 9/16	9 1/4	4	1
SAF536	7 1/2	26 3/4	7 1/8	3	23 5/8	20 7/8	4 5/8	15 1/2	9 11/16	4	1
SAF538	7 7/8	28	7 1/2	3 1/8	24 3/8	21 5/8	4 1/2	15 11/16	10 5/8	4	1 1/4
SAF540	8 1/4	29 1/2	8	3 3/8	25	22 1/2	5	17 3/16	10 5/8	4	1 1/4
SAF544	9 1/2	32 3/4	8 3/4	3 3/4	27 7/8	24 3/4	5 1/4	19 5/8	11 1/2	4	1 1/2

SAF-600 SERIES

SAF615	4	13 3/4	3 7/8	1 5/16	11 5/8	10 3/8	--	7 13/16	6 1/8	2	5/8
SAF617*	4 1/2	15 1/4	4 3/8	1 3/4	13 1/8	11 5/8	--	8 11/16	6 5/8	2	7/8
FSAF617	4 1/2	15 1/4	4 3/8	1 3/4	13 1/8	11 5/8	2 3/8	8 11/16	6 5/8	4	3/4
SAF618	4 3/4	15 1/2	4 3/8	2	13 1/2	12	2 1/4	9 3/16	6 7/8	4	3/4
SAF620	5 1/4	16 1/2	4 3/4	2 1/8	14 1/2	13 1/4	2 3/4	10 1/4	7 1/4	4	3/4
SAF622	6	18 3/8	5 1/8	2 3/8	16	14 5/8	3 1/4	11 9/16	7 7/8	4	7/8
SAF624	6 5/16	21 1/4	6 1/4	2 1/2	18 1/4	17	3 3/4	12 1/2	8 1/4	4	1
SAF626	6 11/16	22	6 1/4	2 5/8	19 1/4	17 3/8	3 3/4	13 5/16	8 5/8	4	1
SAF628	7 1/16	24 3/4	6 3/4	2 3/4	21 5/8	19 3/8	4 1/4	14 9/16	9 1/4	4	1
SAF630	7 1/2	26 3/4	7 1/8	3	23 5/8	20 7/8	4 5/8	15 1/2	9 11/16	4	1
SAF632	7 7/8	28	7 1/2	3 1/8	24 3/8	21 5/8	4 1/2	15 11/16	10 5/8	4	1 1/4
SAF634	8 1/4	29 1/2	8	3 3/8	25	22 1/2	5	17 3/16	10 13/16	4	1 1/4
SAF636	8 7/8	31 1/4	8 1/4	3 1/2	26 5/8	24	5 1/4	18 1/2	11 1/4	4	1 1/4
SAF638	9 1/2	32 3/4	8 3/4	3 3/4	27 7/8	24 1/4	5 1/4	19 5/8	11 1/2	4	1 1/2
SAF640	9 7/8	34 1/4	9	4 3/32	29 1/2	26 1/4	5 1/2	20 3/16	12 1/4	4	1 1/2



PILLOW BLOCKS

SAF 230 SERIES

CAST IRON PILLOW BLOCKS

TAPERED BORE/ADAPTER MOUNTING

Large Bore

SAF-230 SERIES

SHAFT DIA. S-1 IN.	PILLOW BLOCK HOUSING ONLY	SHAFT DIA.	STABILIZING RING 1 REQUIRED	TRIPLE SEAL 2 REQUIRED	COMPLETE PILLOW BLOCK NO.	ADAPTER NO.	APP. WT. (LB.)
4 3/16	SAF024		SR-20-17	LER113	SAF23024	SNW-3024	60
4 7/16	SAF026		SR-22-19	LER117	SAF23026	SNW-3026	76
4 15/16	SAF028		SR-0-20	LER122	SAF23028	SNW-3028	90
5 7/16	SAF032		SR-0-22	LER130	SAF23032	SNW-3032	132
6 15/16	SAF038		SR-32-0	LER155	SAF23038	SNW-3038	220
7 3/16	SAF040		SR-34-0	LER159	SAF23040	SNW-3040	295
7 15/16	SAF044		SR-38-32	LER167	SAF23044	SNW-3044	370
8 7/16	SAF048	8 7/16	A8897	LER526	SAF23048	SNP-3048	430
8 1/2	SAF048	8 1/2	A8897	LER527	SAF23048	SNP-3048	428
8 15/16	SAF048	8 15/16	A8897	LER529	SAF23048	SNP-3048	422
9	SAF048	9	A8897	LER530	SAF23048	SNP-3048	420
9 7/16	SAF052	9 7/16	A8898	LER178-1	SAF23052	SNP-3052	587
9 1/2	SAF052	9 1/2	A8898	LER178	SAF23052	SNP-3052	585
9 15/16	SAF056	9 15/16	A8819	ER751	SAF23056	SNP-3056	640
10	SAF056	10	A8819	ER705	SAF23056	SNP-3056	635
10 7/16	SAF056	10 7/16	A8819	ER745	SAF23056	SNP-3056	625
10 1/2	SAF056	10 1/2	A8819	ER710	SAF23056	SNP-3056	620

NOTES:

Triple seal rings (LER series) and stabilizing ring (SR series) are included with the pillow block.

Stabilizing ring used only for "fixed" mounting, not used for "free" mounting.

* Pillow blocks with 2-hole mounting base, all others have 4-hole mounting base.

PILLOW BLOCKS



SAF 230 SERIES

CAST IRON PILLOW BLOCKS
TAPERED BORE/ADAPTER MOUNTING

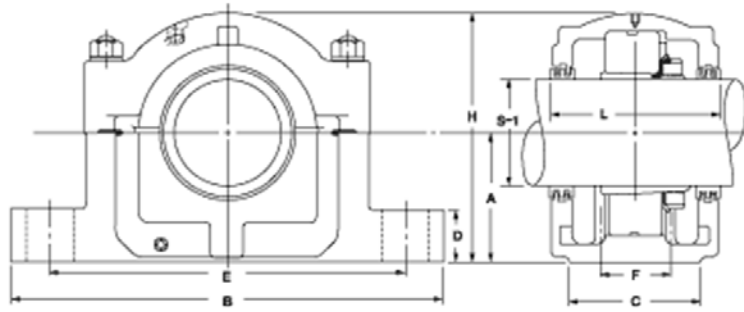

SAF-230 SERIES

PILLOW BLOCK HOUSING ONLY	SHAFT DIA.	A	B	C	D	E		F	H	L	BASE BOLTS REQUIRED	
						MAX.	MIN.				NO.	SIZE
SAF024		4 1/2	15 1/4	4 3/8	1 3/4	13 1/8	11 5/8	2 3/8	8 11/16	5 7/8	4	3/4
SAF026		4 15/16	16 1/2	4 3/4	2	14 7/16	12 5/8	2 3/4	9 9/16	6 1/4	4	3/4
SAF028		5 1/4	16 1/2	4 3/4	2 1/8	14 1/2	13 1/4	2 3/4	10 1/4	7 1/4	4	3/4
SAF032		6	18 3/8	5 1/8	2 3/8	16	14 5/8	3 1/4	11 9/16	7 7/8	4	7/8
SAF038		6 11/16	22	6 1/4	2 5/8	19 1/4	17 3/8	3 3/4	13 5/16	8 5/8	4	1
SAF040		7 1/16	24 3/4	6 3/4	2 13/16	21 5/8	19 3/8	4 1/2	14 9/16	9 1/4	4	1
SAF044		7 7/8	28	7 1/2	3 1/8	24 3/8	21 5/8	4 1/2	15 11/16	10 5/8	4	
SAF048	8 7/16	8 1/4	29 1/2	8	3 3/8	25	22 1/2	5	17 3/16	10 13/16	4	1 1/4
SAF048	8 1/2	8 1/4	29 1/2	8	3 3/8	25	22 1/2	5	17 3/16	10 13/16	4	1 1/4
SAF048	8 15/16	8 1/4	29 1/2	8	3 3/8	25	22 1/2	5	17 3/16	10 13/16	4	1 1/4
SAF048	9	8 1/4	29 1/2	8	3 3/8	25	22 1/2	5	17 3/16	10 13/16	4	1 1/4
SAF052	9 7/16	9 1/2	32 3/4	8 3/4	3 3/4	27 7/8	24 3/4	5 1/4	19 5/8	11 1/2	4	1 1/2
SAF052	9 1/2	9 1/2	32 3/4	8 3/4	3 3/4	27 7/8	24 3/4	5 1/4	19 5/8	11 1/2	4	1 1/2
SAF056	9 15/16	9 7/8	34 1/4	9	4 3/32	29 1/2	26 1/4	5 1/2	20 3/16	12 1/4	4	1 1/2
SAF056	10	9 7/8	34 1/4	9	4 3/32	29 1/2	26 1/4	5 1/2	20 3/16	12 1/4	4	1 1/2
SAF056	10 7/16	9 7/8	34 1/4	9	4 3/32	29 1/2	26 1/4	5 1/2	20 3/16	12 1/4	4	1 1/2
SAF056	10 1/2	9 7/8	34 1/4	9	4 3/32	29 1/2	26 1/4	5 1/2	20 3/16	12 1/4	4	1 1/2



PILLOW BLOCKS

SAFS 200 AND 500 SERIES

CAST STEEL PILLOW BLOCKS

STRAIGHT BORE MOUNTING and
TAPERED BORE/ADAPTER MOUNTING

SAFS-200 SERIES STRAIGHT BORE MOUNTING

SHAFT DIA.		PILLOW BLOCK HOUSING ONLY	STABILIZING RING 1 REQUIRED	TRIPLE SEAL		LOCKNUT NO.	LOCKWASHER NO.	COMPLETE PILLOW BLOCK NO.	APP. WT. (LB.)
S-2 IN.	S-3 IN.			S-2 SHAFT 1 REQUIRED	S-3 SHAFT 1 REQUIRED				
3 15/16	3 3/16	SAFS217*	SR-17-14	LER89	LER63	AN17	W17	SAFS22217	43
3 15/16	3 3/16	FSAFS217	SR-17-14	LER89	LER63	AN17	W17	FSAFS22217	43
4 1/8	3 3/8	SAFS218*	SR-18-15	LER96	LER72	AN18	W18	SAFS22218	50
4 1/8	3 3/8	FSAFS218	SR-18-15	LER96	LER72	AN18	W18	FSAFS22218	50
4 1/2	3 13/16	SAFS220*	SR-20-17	LER118	LER106	AN20	W20	SAFS22220	71
4 1/2	3 13/16	FSAFS220	SR-20-17	LER118	LER106	AN20	W20	FSAFS22220	71
4 7/8	4 3/16	SAFS222	SR-22-19	LER121	LER113	AN22	W22	SAFS22222	81
5 5/16	4 9/16	SAFS224	SR-24-20	LER127	LER119	AN24	W24	SAFS22224	90
5 7/8	4 15/16	SAFS226	SR-26-0	LER136	LER122	AN26	W26	SAFS22226	127
6 1/4	5 5/16	SAFS228	SR-28-0	LER144	LER127	AN28	W28	SAFS22228	149
6 5/8	5 3/4	SAFS230	SR-30-0	LER151	LER134	AN30	W30	SAFS22230	175
7	6 1/16	SAFS232	SR-32-0	LER156	LER142	AN32	W32	SAFS22232	210
7 7/16	6 7/16	SAFS234	SR-34-0	LER161	LER148	AN34	W34	SAFS22234	280
7 13/16	6 7/8	SAFS236	SR-36-30	LER165	LER154	AN36	W36	SAFS22236	305
8 3/8	7 1/4	SAFS238	SR-38-32	LER171	LER160	AN38	W38	SAFS22238	350
8 3/4	7 5/8	SAFS240	SR-40-34	LER175	LER164	AN40	W40	SAFS22240	420
9 9/16	8 5/16	SAFS244	SR-44-38	LER179	LER170	N44	W44	SAFS22244	590

SAFS-500 ADAPTER MOUNTING

S-1 IN.			2 REQUIRED	ADAPTER NO.		
2 7/16	SAFS515*	SR-15-0	LER37	SNW-15	SAFS22515	30
2 7/16	FSAFS515	SR-15-0	LER37	SNW-15	FSAFS22515	30
2 11/16	SAFS516*	SR-16-13	LER44	SNW-16	SAFS22516	37
2 11/16	FSAFS516	SR-16-13	LER44	SNW-16	FSAFS22516	37
2 15/16	SAFS517*	SR-17-14	LER53	SNW-17	SAFS22517	40
2 15/16	FSAFS517	SR-17-14	LER53	SNW-17	FSAFS22517	40
3 3/16	SAFS518*	SR-18-15	LER69	SNW-18	SAFS22518	49
3 3/16	FSAFS518	SR-18-15	LER69	SNW-18	FSAFS22518	49
3 7/16	SAFS520*	SR-20-17	LER102	SNW-20	SAFS22520	65
3 7/16	FSAFS520	SR-20-17	LER102	SNW-20	FSAFS22520	65
3 15/16	SAFS522	SR-22-19	LER109	SNW-22	SAFS22522	81
4 3/16	SAFS524	SR-24-20	LER113	SNW-24	SAFS22524	94
4 7/16	SAFS526	SR-26-0	LER117	SNW-26	SAFS22526	137
4 15/16	SAFS528	SR-28-0	LER122	SNW-28	SAFS22528	159
5 3/16	SAFS530	SR-30-0	LER125	SNW-30	SAFS22530	189
5 7/16	SAFS532	SR-32-0	LER130	SNW-32	SAFS22532	225
5 15/16	SAFS534	SR-34-0	LER140	SNW-34	SAFS22534	300
6 7/16	SAFS536	SR-36-30	LER148	SNW-36	SAFS22536	330
6 15/16	SAFS538	SR-38-32	LER155	SNW-38	SAFS22538	375
7 3/16	SAFS540	SR-40-34	LER159	SNW-40	SAFS22540	445
7 15/16	SAFS544	SR-44-34	LER167	SNW-44	SAFS22544	615

NOTES:

Triple seal rings (LER series) and stabilizing ring (SR series) are included with the pillow block.

Stabilizing ring used only for "fixed" mounting, not used for "free" mounting.

* Pillow blocks with 2-hole mounting base, all others have 4-hole mounting base.

PILLOW BLOCKS



SAFS 200 AND 500 SERIES

CAST STEEL PILLOW BLOCKS

STRAIGHT BORE MOUNTING and
TAPERED BORE/ADAPTER MOUNTING

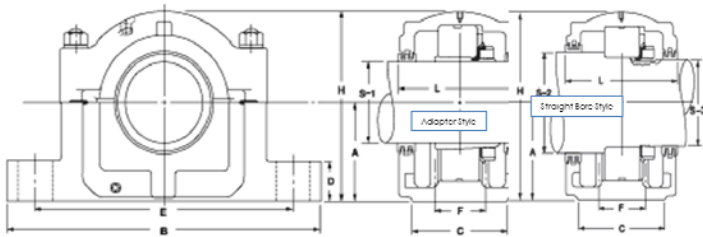

SAFS-200 SERIES STRAIGHT BORE MOUNTING

PILLOW BLOCK HOUSING ONLY	A	B	C	D	E		F	H	L	BASE BOLTS REQUIRED	
					MAX.	MIN.				NO.	SIZE
SAFS217*	3 3/4	13	3 1/2	1 3/16	11	9 7/8	---	7 3/8	4 15/16	2	3/4
FSAFS217	3 3/4	13	3 1/2	1 3/16	11	9 7/8	2 1/8	7 3/8	4 15/16	4	5/8
SAFS218*	4	13 3/4	3 7/8	1 5/16	11 5/8	10 3/8	---	7 3/4	5 5/8	2	3/4
FSAFS218	4	13 3/4	3 7/8	1 5/16	11 5/8	10 3/8	2 1/8	7 3/4	5 5/8	4	5/8
SAFS220*	4 1/2	15 1/4	4 3/8	1 3/4	13 1/8	11 5/8	---	8 11/16	5 7/8	2	7/8
FSAFS220	4 1/2	15 1/4	4 3/8	1 3/4	13 1/8	11 5/8	2 3/8	8 11/16	5 7/8	4	3/4
SAFS222	4 15/16	16 1/2	4 3/4	1 29/32	14 1/2	12 5/8	2 3/4	9 5/8	6 1/4	4	3/4
SAFS224	5 1/4	16 1/2	4 3/4	2 1/8	14 1/2	13 1/4	2 3/4	10 1/4	7 1/8	4	3/4
SAFS226	6	18 3/8	5 1/8	2 9/32	16	14 5/8	3 1/4	11 1/2	7 3/4	4	7/8
SAFS228	6	20 1/8	5 7/8	2 13/32	17 1/8	16	3 3/8	11 3/4	7 3/8	4	1
SAFS230	6 5/16	21 1/4	6 1/4	2 13/32	18 1/4	17	3 3/4	12 1/2	8 1/8	4	1
SAFS232	6 11/16	22	6 1/4	2 5/8	19 1/4	17 3/8	3 3/4	13 5/16	8 1/2	4	1
SAFS234	7 1/16	24 3/4	6 3/4	2 3/4	21 5/8	19 3/8	4 1/4	14 3/16	9 3/8	4	1
SAFS236	7 1/2	26 3/4	7 1/8	3	23 5/8	20 7/8	4 5/8	14 7/8	10	4	1
SAFS238	7 7/8	28	7 1/2	3 1/8	24 3/8	21 5/8	4 1/2	15 11/16	10 1/2	4	1 1/4
SAFS240	8 1/4	29 1/2	8	3 3/8	25	22 1/2	5	17 3/16	11	4	1 1/4
SAFS244	9 1/2	32 3/4	8 3/4	3 3/4	27 7/8	24 3/4	5 1/4	19 5/8	11 5/8	4	1 1/2

SAFS-500 ADAPTER MOUNTING

SAFS515*	3 1/8	11 1/4	3 1/8	1 1/8	9 5/8	8 5/8	---	6 3/8	4 11/16	2	5/8
FSAFS515	3 1/8	11 1/4	3 1/8	1 1/8	9 5/8	8 5/8	1 7/8	6 3/8	4 11/16	4	1/2
SAFS516*	3 1/2	13	3 1/2	1 1/4	11	9 5/8	---	6 7/8	4 53/64	2	3/4
FSAFS516	3 1/2	13	3 1/2	1 1/4	11	9 5/8	2 1/8	6 7/8	4 53/64	4	5/8
SAFS517*	3 7/8	13	3 1/2	1 3/16	11	9 7/8	---	7 3/8	4 13/16	2	3/4
FSAFS517	3 7/8	13	3 1/2	1 3/16	11	9 7/8	2 1/8	7 3/8	4 13/16	4	5/8
SAFS518*	4	13 3/4	3 7/8	1 5/16	11 5/8	10 3/8	---	7 3/4	5 5/8	2	7/8
FSAFS518	4	13 3/4	3 7/8	1 5/16	11 5/8	10 3/8	2 1/8	7 3/4	5 5/8	4	3/4
SAFS520*	4 1/2	15 1/4	4 3/8	1 3/4	13 1/8	11 5/8	---	8 11/16	5 7/8	2	3/4
FSAFS520	4 1/2	15 1/4	4 3/8	1 3/4	13 1/8	11 5/8	2 3/8	8 11/16	5 7/8	4	3/4
SAFS522	4 15/16	16 1/2	4 3/4	1 29/32	14 1/2	12 5/8	2 3/4	9 5/8	6 1/4	4	7/8
SAFS524	5 1/4	16 1/2	4 3/4	2 1/8	14 1/2	13 1/4	2 3/4	10 1/4	7 1/8	4	1
SAFS526	6	18 3/8	5 1/8	2 9/32	16	14 5/8	3 1/4	11 1/2	7 1/2	4	1
SAFS528	6	20 1/8	5 7/8	2 13/32	17 1/8	16	3 3/8	11 3/4	7 3/8	4	1
SAFS530	6 5/16	21 1/4	6 1/4	2 13/32	18 1/4	17	3 3/4	12 1/2	8 1/8	4	1
SAFS532	6 11/16	22	6 1/4	2 5/8	19 1/4	17 3/8	3 3/4	13 5/16	8 1/2	4	1
SAFS534	7 1/16	24 3/4	6 3/4	2 3/4	21 5/8	19 3/8	4 1/4	14 3/16	9 3/8	4	1
SAFS536	7 1/2	26 3/4	7 1/8	3	23 5/8	20 7/8	4 5/8	14 7/8	10	4	1
SAFS538	7 1/8	28	7 1/2	3 1/8	24 3/8	21 5/8	4 1/2	15 11/16	10 1/2	4	1 1/4
SAFS540	8 1/4	29 1/2	8	3 3/8	25	22 1/2	5	16 1/2	11	4	1 1/4
SAFS544	9 1/2	32 3/4	8 3/4	3 3/4	27 7/8	24 3/4	5 1/4	18 5/8	11 5/8	4	1 1/2



PILLOW BLOCKS



Military Standards

Bearing Accessories



MS-1722 SERIES

LOCKNUT DIMENSIONS

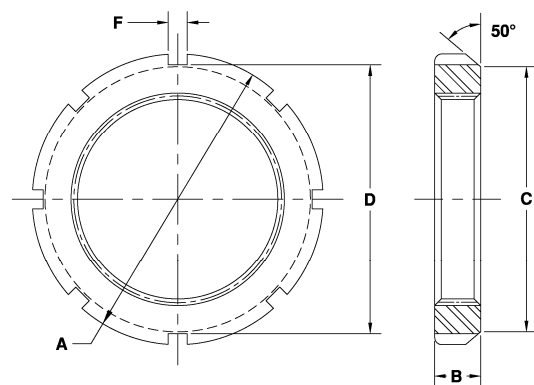

MILITARY STANDARD LOCKNUT DIMENSIONS

LOCKNUT NO.	THREADS		OUTSIDE DIA. A		NUT WIDTH B		FACE DIA. C		SLOT DEPTH D		SLOT WIDTH F		APP. WT. (LB.)
	MAJOR DIA.	NO. PER INCH	MIN.	MAX.	MIN.	MAX.	MIN.	MAX.	MIN.	MAX.	MIN.	MAX.	
MS172236	0.391	32	0.704	0.724	0.173	0.193	0.511	0.531	0.584	0.604	0.115	0.135	0.010
MS172237	0.469	32	0.797	0.817	0.173	0.193	0.605	0.625	0.678	0.698	0.115	0.135	0.014
MS172238	0.586	32	0.923	0.943	0.209	0.229	0.730	0.750	0.802	0.822	0.115	0.135	0.021
MS172239	0.664	32	1.407	1.067	0.209	0.229	0.855	0.875	0.928	0.948	0.115	0.135	0.028
MS172259	0.781	32	1.173	1.193	0.240	0.260	0.980	1.000	1.052	1.072	0.178	0.198	0.036
MS172241	0.969	32	1.360	1.380	0.240	0.260	1.168	1.188	1.240	1.260	0.178	0.198	0.045
MS172242	1.173	18	1.673	1.693	0.271	0.291	1.418	1.438	1.490	1.510	0.178	0.198	0.055
MS172243	1.376	18	1.891	1.911	0.271	0.291	1.636	1.656	1.709	1.729	0.178	0.198	0.067
MS172244	1.563	18	2.079	2.099	0.271	0.291	1.824	1.844	1.896	1.916	0.240	0.260	0.074
MS172245	1.767	18	2.297	2.317	0.302	0.322	2.042	2.062	2.115	2.135	0.240	0.260	0.134
MS172246	1.967	18	2.485	2.505	0.302	0.322	2.230	2.250	2.302	2.322	0.240	0.260	0.144
MS172247	2.157	18	2.735	2.755	0.302	0.322	2.480	2.500	2.552	2.572	0.240	0.260	0.180
MS172248	2.360	18	2.923	2.943	0.334	0.354	2.668	2.688	2.740	2.760	0.240	0.260	0.211
MS172249	2.548	18	3.110	3.130	0.334	0.354	2.855	2.875	2.928	2.948	0.240	0.260	0.224
MS172250	2.751	18	3.329	3.349	0.334	0.354	3.074	3.094	3.146	3.166	0.240	0.260	0.232
MS172251	2.933	12	3.673	3.693	0.365	0.385	3.355	3.375	3.428	3.448	0.365	0.385	0.371
MS172252	3.137	12	3.891	3.911	0.365	0.385	3.574	3.594	3.646	3.666	0.365	0.385	0.405
MS172253	3.340	12	4.110	4.130	0.365	0.385	3.792	3.812	3.865	3.885	0.365	0.385	0.440
MS172254	3.527	12	4.297	4.317	0.365	0.385	3.980	4.000	4.052	4.072	0.365	0.385	0.464
MS172255	3.730	12	4.516	4.536	0.396	0.416	4.199	4.219	4.271	4.291	0.365	0.385	0.546
MS172256	3.918	12	4.704	4.724	0.396	0.416	4.386	4.406	4.459	4.479	0.365	0.385	0.572
MS172257	4.122	12	4.891	4.911	0.396	0.416	4.574	4.594	4.646	4.666	0.490	0.510	0.577
MS172258	4.325	12	5.110	5.130	0.396	0.416	4.792	4.812	4.865	4.885	0.490	0.510	0.620

MS-1722 SERIES LOCKNUTS



MS-1722 SERIES

LOCKWASHER DIMENSIONS

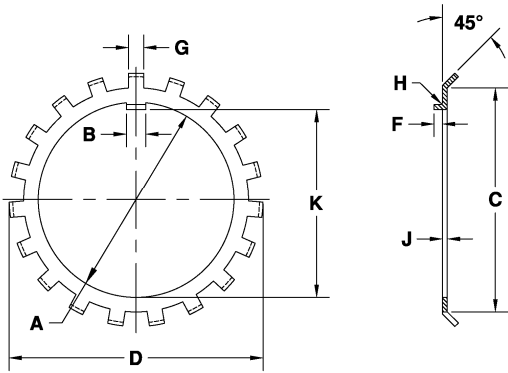

MILITARY STANDARD LOCKWASHER DIMENSIONS

LOCKWASHER NO.	BORE		KEY WIDTH		FACE DIA.	DIA. OVER TANGS		KEY PROJECTION		TANG WIDTH		RADIUS		THICKNESS		INSIDE DIMENSION	NO. OF TANGS	APP. WT. (LB.)
	A		B		C	D	F		G		H	J		K	L			
	MIN.	MAX.	MIN.	MAX.	+0.020/-0.000	+0.000/-0.030	MIN.	MAX.	MIN.	MAX.		MIN.	MAX.	+0.020/-0.000				
MS172201	0.406	0.421	0.110	0.120	0.531	0.828	0.062	0.094	0.084	0.104	0.016	0.036	0.044	0.333	9	0.003		
MS172202	0.484	0.499	0.110	0.120	0.625	0.922	0.062	0.094	0.084	0.104	0.016	0.036	0.044	0.411	9	0.004		
MS172203	0.601	0.616	0.110	0.120	0.750	1.094	0.062	0.094	0.084	0.104	0.016	0.036	0.044	0.513	11	0.005		
MS172204	0.679	0.694	0.110	0.120	0.875	1.203	0.062	0.094	0.084	0.104	0.016	0.036	0.044	0.591	11	0.006		
MS172205	0.801	0.816	0.156	0.176	0.969	1.344	0.062	0.094	0.146	0.166	0.016	0.036	0.044	0.724	11	0.008		
MS172206	0.989	1.009	0.156	0.176	1.188	1.562	0.094	0.125	0.146	0.166	0.016	0.046	0.054	0.880	13	0.013		
MS172207	1.193	1.213	0.156	0.176	1.438	1.859	0.094	0.125	0.146	0.166	0.031	0.046	0.054	1.084	13	0.016		
MS172208	1.396	1.416	0.156	0.176	1.656	2.078	0.094	0.125	0.146	0.166	0.031	0.046	0.054	1.287	15	0.019		
MS172209	1.583	1.603	0.280	0.300	1.844	2.250	0.094	0.125	0.204	0.234	0.031	0.058	0.068	1.474	15	0.030		
MS172210	1.792	1.817	0.280	0.300	2.062	2.500	0.125	0.156	0.204	0.234	0.031	0.058	0.068	1.693	17	0.037		
MS172211	1.992	2.017	0.280	0.300	2.250	2.688	0.125	0.156	0.204	0.234	0.031	0.058	0.068	1.880	17	0.037		
MS172212	2.182	2.207	0.280	0.300	2.500	2.953	0.125	0.156	0.204	0.234	0.031	0.058	0.068	2.067	17	0.042		
MS172213	2.400	2.425	0.280	0.300	2.688	3.188	0.125	0.156	0.204	0.234	0.047	0.058	0.068	2.255	17	0.044		
MS172214	2.588	2.613	0.280	0.300	2.875	3.375	0.125	0.156	0.204	0.234	0.047	0.058	0.068	2.443	19	0.048		
MS172215	2.791	2.816	0.280	0.300	3.094	3.594	0.188	0.250	0.204	0.234	0.047	0.058	0.068	2.631	19	0.052		
MS172216	2.973	3.003	0.280	0.300	3.375	3.922	0.188	0.250	0.297	0.327	0.047	0.058	0.068	2.813	19	0.077		
MS172217	3.177	3.207	0.340	0.360	3.594	4.141	0.188	0.250	0.297	0.327	0.047	0.058	0.068	3.017	19	0.081		
MS172218	3.395	3.425	0.340	0.360	3.812	4.359	0.188	0.250	0.297	0.327	0.047	0.058	0.068	3.220	19	0.084		
MS172219	3.582	3.612	0.340	0.360	4.000	4.547	0.188	0.250	0.297	0.327	0.047	0.058	0.068	3.380	19	0.086		
MS172220	3.800	3.830	0.340	0.360	4.219	4.812	0.188	0.250	0.297	0.327	0.047	0.058	0.068	3.579	19	0.092		
MS172221	3.988	4.018	0.340	0.360	4.406	5.000	0.250	0.312	0.297	0.327	0.047	0.058	0.068	3.786	19	0.094		
MS172222	4.192	4.222	0.340	0.360	4.594	5.188	0.250	0.312	0.360	0.390	0.047	0.058	0.068	4.071	19	0.104		
MS172223	4.395	4.425	0.340	0.360	4.812	5.406	0.250	0.312	0.360	0.390	0.047	0.058	0.068	4.193	19	0.108		
MS172224	0.801	0.816	0.156	0.176	1.000	1.375	0.062	0.094	0.146	0.166	0.016	0.036	0.044	0.724	11	0.009		



MS-1722 LOCKWASHERS

MS-19067 SERIES

LOCKNUT DIMENSIONS

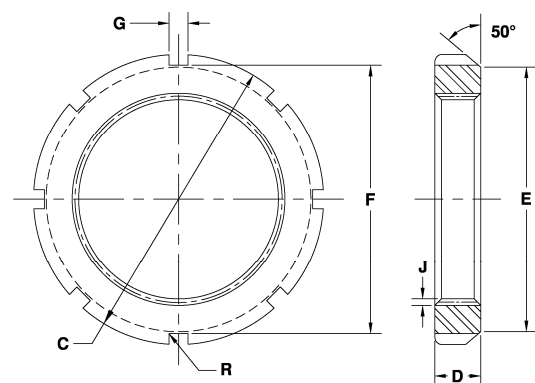

MILITARY STANDARD LOCKNUT DIMENSIONS

LOCKNUT NO.	NUT WIDTH D	OUTSIDE DIA. C	FACE DIA. E	INSIDE CHAMFER J	SLOT DIA. F	SLOT WIDTH G	SLOT RAD. R	NO. PER INCH	THREAD DATA				
									MINOR DIA.		PITCH DIA.		MAJOR DIA.
									MIN.	MAX.	MIN.	MAX.	MIN.
MS 19067-A00	0.188	0.719	0.531	0.031	0.594	0.125	0.010	32	0.357	0.361	0.371	0.373	0.391
MS 19067-A01	0.188	0.812	0.625	0.031	0.688	0.125	0.010	32	0.435	0.439	0.449	0.451	0.469
MS 19067-A02	0.219	0.938	0.750	0.031	0.812	0.125	0.010	32	0.552	0.556	0.566	0.569	0.586
MS 19067-A03	0.219	1.062	0.875	0.031	0.938	0.125	0.010	32	0.630	0.634	0.644	0.647	0.664
MS 19067-A04	0.250	1.156	0.969	0.031	1.031	0.188	0.015	32	0.747	0.751	0.761	0.764	0.781
MS 19067-A05	0.250	1.375	1.188	0.031	1.250	0.188	0.015	32	0.935	0.939	0.949	0.952	0.969
MS 19067-A06	0.281	1.688	1.438	0.047	1.500	0.188	0.015	18	1.113	1.119	1.137	1.141	1.173
MS 19067-A07	0.281	1.906	1.656	0.047	1.719	0.188	0.015	18	1.316	1.322	1.340	1.344	1.376
MS 19067-A08	0.281	2.094	1.844	0.047	1.906	0.250	0.020	18	1.503	1.509	1.527	1.531	1.563
MS 19067-A09	0.312	2.312	2.062	0.047	2.125	0.250	0.020	18	1.707	1.713	1.731	1.735	1.767
MS 19067-A10	0.312	2.500	2.250	0.047	2.312	0.250	0.020	18	1.907	1.913	1.931	1.935	1.967
MS 19067-A11	0.312	2.750	2.500	0.047	2.562	0.250	0.020	18	2.097	2.103	2.121	2.126	2.157
MS 19067-A12	0.344	2.938	2.688	0.047	2.750	0.250	0.020	18	2.300	2.306	2.324	2.329	2.360
MS 19067-A13	0.344	3.125	2.875	0.047	2.937	0.250	0.020	18	2.488	2.494	2.512	2.517	2.548
MS 19067-A14	0.344	3.344	3.094	0.047	3.156	0.250	0.020	18	2.691	2.697	2.715	2.720	2.751
MS 19067-A15	0.375	3.688	3.375	0.078	3.438	0.375	0.025	12	2.843	2.852	2.879	2.884	2.933
MS 19067-A16	0.375	3.906	3.594	0.078	3.656	0.375	0.025	12	3.047	3.056	3.083	3.089	3.137
MS 19067-A17	0.375	4.125	3.812	0.078	3.875	0.375	0.025	12	3.250	3.259	3.286	3.293	3.340
MS 19067-A18	0.375	4.312	4.000	0.078	4.062	0.375	0.025	12	3.437	3.446	3.473	3.480	3.527
MS 19067-A19	0.406	4.531	4.219	0.078	4.281	0.375	0.025	12	3.640	3.649	3.676	3.683	3.730
MS 19067-A20	0.406	4.719	4.406	0.078	4.469	0.375	0.025	12	3.828	3.837	3.864	3.871	3.918
MS 19067-A21	0.406	4.906	4.594	0.078	4.656	0.500	0.030	12	4.032	4.041	4.068	4.076	4.122
MS 19067-A22	0.406	5.125	4.812	0.078	4.875	0.500	0.030	12	4.235	4.244	4.271	4.279	4.325

MS-19067 SERIES LOCKNUTS



MS-19069 SERIES

LOCKWASHER DIMENSIONS

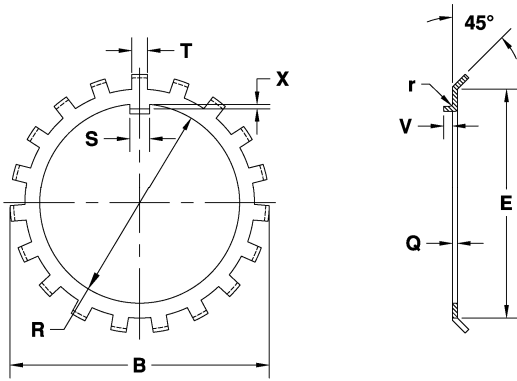

MILITARY STANDARD LOCKWASHER DIMENSIONS

LOCKWASHER NO.	THICKNESS		BORE		FACE DIA.	DIA. OVER TANGS	KEY WIDTH		KEY DEPTH		KEY PROJECTION		NO. OF TANGS	TANG WIDTH		
	Q		R		E	B	S		X		V			T		
	NOM.	TOL. +/-	MAX.	MIN.	+0.020/-0.000	+0.000/-0.030	MAX.	MIN.	MAX.	MIN.	NOM.	TOL. +/-		MAX.	MIN.	
MS 19069-A00	0.042	0.004	0.421	0.406	0.531	0.828	0.120	0.110	0.030	0.020	0.062	0.031	0.016	9	0.104	0.084
MS 19069-A01	0.042	0.004	0.499	0.484	0.625	0.922	0.120	0.110	0.030	0.020	0.062	0.031	0.016	9	0.104	0.084
MS 19069-A02	0.042	0.004	0.616	0.601	0.750	1.094	0.120	0.110	0.030	0.020	0.062	0.031	0.016	11	0.104	0.084
MS 19069-A03	0.042	0.004	0.694	0.679	0.875	1.203	0.120	0.110	0.030	0.020	0.062	0.031	0.016	11	0.104	0.084
MS 19069-A04	0.042	0.004	0.816	0.801	0.969	1.344	0.176	0.156	0.030	0.020	0.062	0.031	0.016	11	0.166	0.146
MS 19069-A23	0.042	0.004	0.816	0.801	1.000	1.375	0.120	0.110	0.030	0.020	0.062	0.031	0.016	11	0.166	0.146
MS 19069-A05	0.050	0.004	1.009	0.989	1.188	1.562	0.176	0.156	0.030	0.020	0.094	0.031	0.016	13	0.166	0.146
MS 19069-A06	0.050	0.004	1.213	1.193	1.438	1.859	0.176	0.156	0.050	0.035	0.094	0.031	0.031	13	0.166	0.146
MS 19069-A07	0.050	0.004	1.416	1.396	1.656	2.078	0.176	0.156	0.050	0.035	0.094	0.031	0.031	15	0.166	0.146
MS 19069-A08	0.058	0.005	1.603	1.583	1.844	2.250	0.300	0.280	0.050	0.035	0.094	0.031	0.031	15	0.234	0.204
MS 19069-A09	0.058	0.005	1.817	1.792	2.062	2.500	0.300	0.280	0.050	0.035	0.125	0.031	0.031	17	0.234	0.204
MS 19069-A10	0.058	0.005	2.017	1.992	2.250	2.688	0.300	0.280	0.050	0.035	0.125	0.031	0.031	17	0.234	0.204
MS 19069-A11	0.063	0.005	2.207	2.182	2.500	2.953	0.300	0.280	0.050	0.035	0.125	0.031	0.031	17	0.234	0.204
MS 19069-A12	0.063	0.005	2.425	2.400	2.688	3.188	0.300	0.280	0.070	0.055	0.125	0.031	0.047	17	0.234	0.204
MS 19069-A13	0.063	0.005	2.613	2.588	2.875	3.375	0.300	0.280	0.070	0.055	0.125	0.031	0.047	19	0.234	0.204
MS 19069-A14	0.063	0.005	2.816	2.791	3.094	3.594	0.300	0.280	0.070	0.055	0.188	0.062	0.047	19	0.234	0.204
MS 19069-A15	0.063	0.005	3.003	2.973	3.375	3.922	0.300	0.280	0.070	0.055	0.188	0.062	0.047	19	0.327	0.297
MS 19069-A16	0.063	0.005	3.207	3.177	3.594	4.141	0.360	0.340	0.070	0.055	0.188	0.062	0.047	19	0.327	0.297
MS 19069-A17	0.063	0.005	3.425	3.395	3.812	4.359	0.360	0.340	0.070	0.055	0.188	0.062	0.047	19	0.327	0.297
MS 19069-A18	0.063	0.005	3.612	3.582	4.000	4.547	0.360	0.340	0.070	0.055	0.188	0.062	0.047	19	0.327	0.297
MS 19069-A19	0.063	0.005	3.830	3.800	4.219	4.812	0.360	0.340	0.070	0.055	0.188	0.062	0.047	19	0.327	0.297
MS 19069-A20	0.063	0.005	4.018	3.988	4.405	5.000	0.360	0.340	0.085	0.065	0.250	0.062	0.047	19	0.327	0.297
MS 19069-A21	0.063	0.005	4.222	4.192	4.594	5.185	0.360	0.340	0.085	0.065	0.250	0.062	0.047	19	0.390	0.360
MS 19069-A22	0.063	0.005	4.425	4.395	4.812	5.406	0.360	0.340	0.085	0.065	0.250	0.062	0.047	19	0.390	0.360



MS-19069 LOCKWASHERS

MS-19068 SERIES

LOCKNUT DIMENSIONS

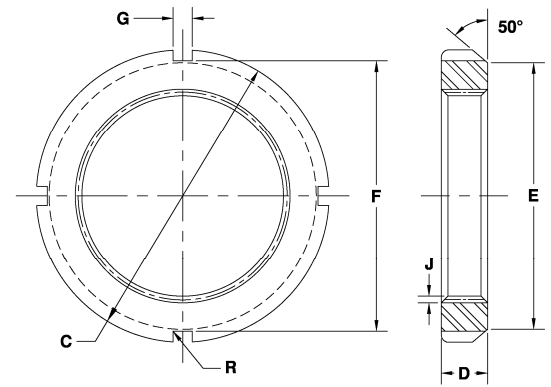

MILITARY STANDARD LOCKNUT DIMENSIONS

LOCKNUT NO.	THICKNESS		OUTSIDE DIA.		FACE DIA.		INSIDE CHAMFER		SLOT DIA.		SLOT WIDTH		SLOT RADIUS		THREAD DATA			APP. WT. (LB./C)
	D		C +.005/- .015	E		J	F +.010/- .020	G		R	NO. PER INCH	MINOR DIA.		PITCH DIA.		MAJOR DIA.		
	MIN.	MAX.		MIN.	MAX.			MIN.	MAX.			MIN.	MAX.	MIN.	MAX.			
MS19068-00	0.209	0.229	0.750	0.605	0.625	0.031	0.625	0.120	0.130	0.010	32	0.357	0.361	0.371	0.373	0.391	2.0	
MS19068-01	0.303	0.323	0.875	0.699	0.719	0.031	0.750	0.120	0.130	0.010	32	0.435	0.439	0.449	0.451	0.469	3.3	
MS19068-02	0.303	0.323	1.000	0.793	0.813	0.031	0.812	0.120	0.130	0.010	32	0.552	0.556	0.566	0.569	0.586	3.5	
MS19068-03	0.334	0.354	1.125	0.918	0.938	0.031	0.937	0.120	0.130	0.010	32	0.630	0.634	0.644	0.647	0.664	5.3	
MS19068-04	0.365	0.385	1.375	1.105	1.125	0.031	1.187	0.178	0.198	0.015	32	0.747	0.751	0.761	0.764	0.781	9.0	
MS19068-05	0.396	0.416	1.562	1.261	1.281	0.031	1.375	0.178	0.198	0.015	32	0.935	0.939	0.949	0.952	0.969	11.5	
MS19068-06	0.396	0.416	1.750	1.480	1.500	0.047	1.562	0.178	0.198	0.015	18	1.113	1.119	1.137	1.141	1.173	13.0	
MS19068-065	0.428	0.448	2.062	1.793	1.813	0.047	1.875	0.178	0.198	0.015	18	1.252	1.258	1.276	1.280	1.313	21.0	
MS19068-07	0.428	0.448	2.062	1.793	1.813	0.047	1.875	0.178	0.198	0.015	18	1.316	1.322	1.340	1.344	1.376	22.5	
MS19068-08	0.428	0.448	2.250	1.980	2.000	0.047	2.062	0.240	0.260	0.020	18	1.503	1.509	1.527	1.531	1.563	29.0	
MS19068-09	0.428	0.448	2.531	2.261	2.281	0.047	2.343	0.240	0.260	0.020	18	1.707	1.713	1.731	1.735	1.767	34.0	
MS19068-10	0.490	0.510	2.687	2.418	2.438	0.047	2.500	0.240	0.260	0.020	18	1.907	1.913	1.931	1.935	1.967	42.0	
MS19068-11	0.490	0.510	2.968	2.636	2.656	0.047	2.718	0.240	0.260	0.020	18	2.097	2.103	2.121	2.126	2.157	47.0	
MS19068-12	0.521	0.541	3.156	2.824	2.844	0.047	2.906	0.240	0.260	0.020	18	2.300	2.306	2.324	2.329	2.360	55.0	
MS19068-13	0.553	0.573	3.375	3.043	3.063	0.047	3.125	0.240	0.260	0.020	18	2.488	2.494	2.512	2.517	2.548	63.8	
MS19068-14	0.553	0.573	3.625	3.283	3.313	0.047	3.375	0.240	0.260	0.020	18	2.691	2.697	2.715	2.720	2.751	78.8	
MS19068-15	0.584	0.604	3.875	3.533	3.563	0.078	3.625	0.360	0.385	0.025	12	2.843	2.852	2.879	2.884	2.933	92.5	
MS19068-16	0.584	0.604	4.156	3.814	3.844	0.078	3.906	0.360	0.385	0.025	12	3.047	3.056	3.083	3.089	3.137	104.0	
MS19068-17	0.615	0.635	4.406	4.001	4.031	0.078	4.093	0.360	0.385	0.025	12	3.250	3.259	3.286	3.292	3.340	130.0	
MS19068-18	0.678	0.698	4.656	4.251	4.281	0.078	4.343	0.360	0.385	0.025	12	3.437	3.446	3.473	3.480	3.527	153.8	
MS19068-19	0.709	0.729	4.937	4.533	4.563	0.078	4.625	0.360	0.385	0.025	12	3.640	3.649	3.676	3.683	3.730	178.8	
MS19068-20	0.735	0.760	5.187	4.783	4.813	0.078	4.875	0.360	0.385	0.025	12	3.828	3.837	3.864	3.871	3.918	193.8	
MS19068-21	0.735	0.760	5.437	4.970	5.000	0.078	5.062	0.485	0.510	0.030	12	4.032	4.041	4.068	4.076	4.122	223.0	
MS19068-22	0.766	0.791	5.718	5.251	5.281	0.078	5.343	0.485	0.510	0.030	12	4.235	4.244	4.271	4.279	4.325	255.0	
MS19068-24	0.798	0.823	6.125	5.658	5.688	0.078	5.750	0.485	0.510	0.030	12	4.626	4.635	4.662	4.670	4.716	317.0	
MS19068-26	0.860	0.885	6.750	6.158	6.188	0.078	6.250	0.610	0.635	0.030	12	5.016	5.025	5.052	5.060	5.106	355.0	
MS19068-28	0.923	0.948	7.093	6.501	6.531	0.078	6.593	0.610	0.635	0.030	12	5.407	5.416	5.443	5.451	5.497	475.0	
MS19068-30	0.954	0.979	7.687	7.033	7.063	0.078	7.125	0.610	0.635	0.030	12	5.798	5.807	5.834	5.842	5.888	525.0	
MS19068-32	1.016	1.041	8.062	7.398	7.438	0.094	7.500	0.610	0.635	0.030	8	6.149	6.162	6.203	6.212	6.284	662.5	
MS19068-34	1.048	1.073	8.656	7.991	8.031	0.094	8.093	0.610	0.635	0.030	8	6.524	6.537	6.578	6.587	6.659	665.0	
MS19068-36	1.079	1.104	9.062	8.335	8.375	0.094	8.437	0.735	0.760	0.030	8	6.931	6.944	6.985	6.994	7.066	775.0	
MS19068-38	1.110	1.135	9.468	8.741	8.781	0.094	8.843	0.735	0.760	0.030	8	7.337	7.350	7.391	7.400	7.472	850.0	
MS19068-40	1.173	1.198	9.843	9.116	9.156	0.094	9.218	0.735	0.760	0.030	8	7.712	7.725	7.766	7.777	7.847	1,050.0	

MS-19068 SERIES LOCKNUTS



MS-19070 SERIES

LOCKWASHER DIMENSIONS

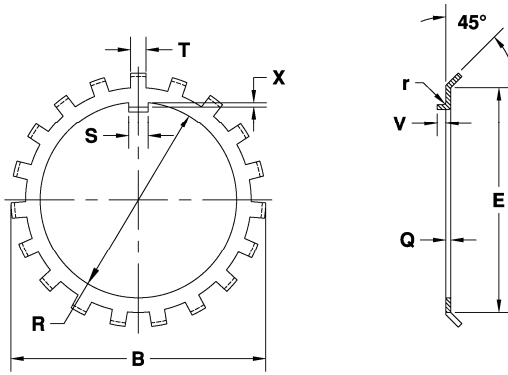

MILITARY STANDARD LOCKWASHER DIMENSIONS

LOCKWASHER NO.	THICKNESS		BORE		FACE DIA.		DIA. OVER TANGS		KEY WIDTH		KEY DEPTH		KEY PROJECTION		SLOT RADIUS	NO. OF TANGS	TANG WIDTH	
	Q		R		E		B		S		X		V		r		T	
	NOM.	TOL +/-	MAX.	MIN.	MIN.	TOL +	MAX.	MAX.	MIN.	MAX.	MIN.	MIN.	TOL+	MIN.	TOL+		NOM.	TOL +/-
MS19070-00	0.042	0.004	0.421	0.406	0.625	0.015	0.875	0.120	0.110	0.030	0.020	0.062	0.031	0.016	9	0.115	0.005	
MS19070-01	0.042	0.004	0.499	0.484	0.719	0.015	1.016	0.120	0.110	0.030	0.020	0.062	0.031	0.016	9	0.115	0.005	
MS19070-02	0.042	0.004	0.616	0.601	0.812	0.015	1.156	0.120	0.110	0.030	0.020	0.062	0.031	0.016	11	0.115	0.005	
MS19070-03	0.042	0.004	0.694	0.679	0.938	0.015	1.328	0.120	0.110	0.030	0.020	0.062	0.031	0.016	11	0.115	0.005	
MS19070-04	0.042	0.004	0.816	0.801	1.125	0.015	1.531	0.176	0.156	0.030	0.020	0.062	0.031	0.016	11	0.156	0.010	
MS19070-05	0.050	0.004	1.009	0.989	1.281	0.015	1.719	0.176	0.156	0.030	0.020	0.094	0.031	0.016	13	0.156	0.010	
MS19070-06	0.050	0.004	1.213	1.193	1.500	0.015	1.922	0.176	0.156	0.050	0.035	0.094	0.031	0.031	13	0.156	0.010	
MS19070-065	0.050	0.004	1.353	1.333	1.812	0.015	2.250	0.176	0.156	0.050	0.035	0.094	0.031	0.031	15	0.156	0.010	
MS19070-07	0.050	0.004	1.416	1.396	1.812	0.015	2.250	0.176	0.156	0.050	0.035	0.094	0.031	0.031	15	0.156	0.010	
MS19070-08	0.058	0.005	1.603	1.583	2.000	0.030	2.469	0.290	0.250	0.050	0.035	0.094	0.031	0.031	15	0.219	0.015	
MS19070-09	0.058	0.005	1.817	1.792	2.281	0.030	2.734	0.290	0.250	0.050	0.035	0.125	0.031	0.031	17	0.219	0.015	
MS19070-10	0.058	0.005	2.017	1.992	2.438	0.030	2.922	0.290	0.250	0.050	0.035	0.125	0.031	0.031	17	0.219	0.015	
MS19070-11	0.063	0.005	2.207	2.182	2.656	0.030	3.109	0.290	0.250	0.050	0.035	0.125	0.031	0.031	17	0.219	0.015	
MS19070-12	0.063	0.005	2.425	2.400	2.844	0.030	3.344	0.290	0.250	0.070	0.055	0.125	0.031	0.047	17	0.219	0.015	
MS19070-13	0.063	0.005	2.613	2.588	3.062	0.030	3.578	0.290	0.250	0.070	0.055	0.125	0.031	0.047	19	0.219	0.015	
MS19070-14	0.063	0.005	2.816	2.791	3.312	0.030	3.828	0.290	0.250	0.070	0.055	0.188	0.062	0.047	19	0.219	0.015	
MS19070-15	0.072	0.005	3.003	2.973	3.562	0.030	4.109	0.290	0.250	0.070	0.055	0.188	0.062	0.047	19	0.313	0.015	
MS19070-16	0.072	0.005	3.207	3.177	3.844	0.030	4.375	0.353	0.313	0.070	0.055	0.188	0.062	0.047	19	0.313	0.015	
MS19070-17	0.072	0.005	3.425	3.395	4.031	0.030	4.625	0.353	0.313	0.070	0.055	0.188	0.062	0.047	19	0.313	0.015	
MS19070-18	0.094	0.006	3.612	3.582	4.281	0.045	4.938	0.353	0.313	0.070	0.055	0.188	0.062	0.047	19	0.313	0.015	
MS19070-19	0.094	0.006	3.830	3.800	4.562	0.045	5.219	0.353	0.313	0.070	0.055	0.188	0.062	0.047	19	0.313	0.015	
MS19070-20	0.094	0.006	4.018	3.988	4.812	0.045	5.500	0.353	0.313	0.085	0.065	0.250	0.062	0.047	19	0.313	0.015	
MS19070-21	0.094	0.006	4.222	4.192	5.000	0.045	5.703	0.353	0.313	0.085	0.065	0.250	0.062	0.047	19	0.375	0.015	
MS19070-22	0.125	0.007	4.425	4.395	5.281	0.045	6.062	0.353	0.313	0.085	0.065	0.250	0.062	0.047	19	0.375	0.015	
MS19070-24	0.125	0.007	4.831	4.801	5.688	0.045	6.469	0.353	0.313	0.085	0.065	0.250	0.062	0.047	19	0.375	0.015	
MS19070-26	0.125	0.007	5.226	5.191	6.188	0.045	7.031	0.435	0.375	0.105	0.085	0.250	0.062	0.062	19	0.500	0.020	
MS19070-28	0.125	0.007	5.617	5.582	6.531	0.045	7.438	0.590	0.500	0.105	0.085	0.250	0.062	0.062	19	0.500	0.020	
MS19070-30	0.156	0.008	6.018	5.983	7.062	0.060	8.062	0.590	0.500	0.105	0.085	0.312	0.062	0.062	19	0.500	0.020	
MS19070-32	0.156	0.008	6.424	6.389	7.438	0.060	8.438	0.590	0.500	0.105	0.085	0.312	0.062	0.062	19	0.500	0.020	
MS19070-34	0.156	0.008	6.799	6.764	8.031	0.060	9.062	0.715	0.625	0.105	0.085	0.312	0.062	0.062	19	0.500	0.020	
MS19070-36	0.156	0.008	7.206	7.171	8.375	0.060	9.438	0.715	0.625	0.105	0.085	0.312	0.062	0.062	19	0.625	0.020	
MS19070-38	0.156	0.008	7.612	7.577	8.781	0.060	9.875	0.715	0.625	0.105	0.085	0.312	0.062	0.062	19	0.625	0.020	
MS19070-40	0.156	0.008	8.017	7.982	9.156	0.060	10.312	0.840	0.750	0.105	0.085	0.312	0.062	0.062	19	0.625	0.020	



MS-19070 LOCKWASHERS



Spanner Wrenches

Bearing Accessories



SPANNER WRENCHES

ADJUSTABLE SPANNER WRENCHES

For standard locknut series



ADJUSTABLE SPANNER WRENCH SIZES

WRENCH NUMBER	FITS LOCKNUT SIZE	FOR DIAMETER	WRENCH OAL
ASW00-06	N00-N06	0.750-2.000	6.375
ASW04-11	N04-N11	1.250-3.000	8.125
ASW08-18	N08-AN18	2.000-4.750	11.375
ASW18-24	AN18-AN24	4.500-6.250	12.125
ASW26-34	AN26-AN34	6.125-8.750	13.750

FIXED SPANNER WRENCHES

For standard locknut series

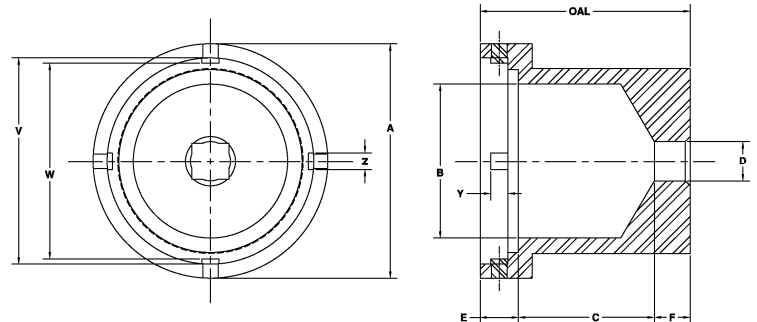

SPANNER WRENCH DIMENSIONS

PART NO.	OUTSIDE	SHAFT	SHAFT EXT.	DRIVE SQ.	RECESS	DRIVE	OAL	ID	DRIVER	DRIVER	DRIVER
	DIA. NOM.	EXT.	LENGTH		DEPTH				SPAN	HEIGHT	WIDTH
	A +/- .015	B MIN.	C MIN.	D +.005/+ .020	E MIN.	F	+/- 0.03	V	W +.010/- .000	Y +.015/- .005	Z
SW-00	1 1/4	3/8	2 1/16	3/8	3/16	3/8	2 3/4	.760-.790	0.670	1/8	.107-.117
SW-01	1 3/8	7/16	2 1/8	3/8	1/4	3/8	2 7/8	.885-.915	0.795	3/16	.107-.117
SW-02	1 1/2	9/16	2 1/8	3/8	1/4	3/8	2 7/8	1.010-1.040	0.860	3/16	.107-.117
SW-03	1 5/8	5/8	2 1/8	3/8	5/16	3/8	3	1.135-1.165	0.983	5/32	.107-.117
SW-04	1 7/8	3/4	2 1/16	3/8	5/16	3/8	3	1.385-1.415	1.252	1/4	.165-.175
SW-05	2 1/16	15/16	2 1/16	3/8	3/8	3/8	3	1.572-1.602	1.440	1/4	.165-.175
SW-06	2 3/8	13/16	2 1/4	1/2	3/8	1/2	3 1/4	1.760-1.790	1.627	1/4	.165-.175
SW-07	2 11/16	13/8	2 1/4	1/2	13/32	1/2	3 1/4	2.072-2.102	1.940	1/4	.165-.175
SW-08	2 7/8	19/16	2 1/4	1/2	13/32	1/2	3 1/4	2.260-2.290	2.137	1/4	.227-.237
SW-09	3 3/16	13/4	2 1/4	1/2	13/32	1/2	3 1/4	2.541-2.571	2.419	1/4	.227-.237
SW-10	3 3/8	115/16	2 5/8	1/2	15/32	1/2	3 3/4	2.698-2.728	2.575	3/8	.227-.237
SW-11	3 5/8	21/8	2 5/8	1/2	15/32	1/2	3 3/4	2.979-3.009	2.794	3/8	.227-.237
SW-12	3 13/16	25/16	2 5/8	1/2	1/2	1/2	3 3/4	3.166-3.196	2.981	3/8	.227-.237
SW-13	4	21/2	2 5/8	1/2	1/2	1/2	3 3/4	3.385-3.415	3.200	3/8	.227-.237
SW-14	4 1/4	23/4	2 5/8	1/2	1/2	1/2	3 3/4	3.635-3.665	3.450	3/8	.227-.237
SW-15	4 1/2	27/8	2 3/4	3/4	9/16	3/4	4 1/4	3.885-3.915	3.640	7/16	.347-.357

Metric Spanner Wrenches are also available (SWM and ASWM).

SPANNER WRENCHES





Rethreading Dies
Clamp Nuts and
X-Washers and Pins
Bearing Accessories



DRT SERIES

RETHREADING DIE DIMENSIONS

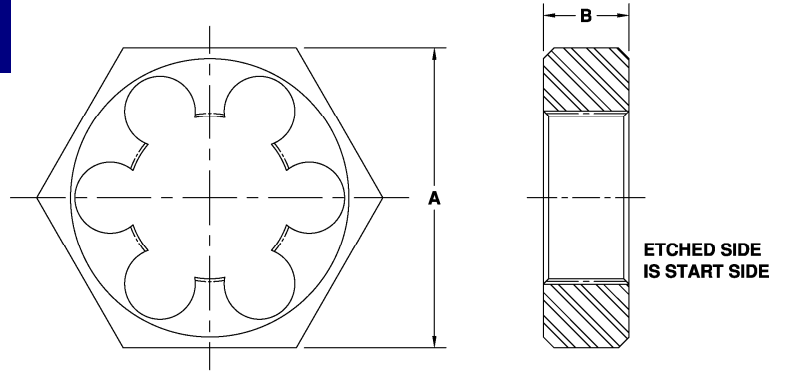

RETHREADING DIE DIMENSIONS

PART NO.	THREAD SIZE	SHAFT THREADS							
		A		MAJOR DIA.		PITCH DIA.		MINOR DIA.	
		+0/-0.10	B +0/-0.015	MAX.	MIN.	MAX.	MIN.	MAX.	
DRT00	.391-32	0.088	0.438	0.391	0.3870	0.3910	0.3870	0.3527	
DRT01	.469-32	1.063	0.500	0.469	0.4650	0.4487	0.4461	0.4307	
DRT02	.586-32	1.250	0.625	0.586	0.5820	0.5657	0.5627	0.5477	
DRT03	.664-32	1.438	0.625	0.664	0.6600	0.6437	0.6407	0.6257	
DRT04	.781-32	1.625	0.875	0.781	0.7770	0.7607	0.7573	0.7427	
DRT05	.969-32	1.625	0.875	0.969	0.9650	0.9487	0.9453	0.9307	
DRT06	1.173-18	1.813	1.000	1.173	1.1680	1.1369	1.1329	1.1048	
DRT065	1.313-18	2.375	1.000	1.313	1.3050	1.2764	1.2724	1.2443	
DRT07	1.376-18	2.375	1.000	1.376	1.3710	1.3399	1.3359	1.3078	
DRT08	1.563-18	3.125	1.000	1.563	1.5580	1.5269	1.5224	1.4948	
DRT09	1.767-18	3.125	1.000	1.767	1.7620	1.7309	1.7264	1.6988	
DRT10	1.967-18	3.500	1.000	1.967	1.9620	1.9309	1.9264	1.8988	
DRT11	2.157-18	3.500	1.000	2.157	2.1520	2.1209	2.1158	2.0888	
DRT12	2.360-18	4.500	1.000	2.360	2.3550	2.3239	2.3188	2.2918	
DRT13	2.548-18	4.500	1.000	2.548	2.5430	2.5119	2.5008	2.4798	
DRT14	2.751-18	4.500	1.000	2.751	2.7460	2.7149	2.7098	2.6828	
DRT15	2.933-12	5.000	1.000	2.933	2.9270	2.8789	2.8735	2.8308	
DRT16	3.137-12	5.000	1.000	3.137	3.1310	3.0829	3.0770	3.0348	
DRT17	3.340-12	5.000	1.000	3.340	3.3360	3.2859	3.2800	3.2378	
DRT18	3.527-12	6.000	1.000	3.527	3.5210	3.4729	3.4655	3.4248	
DRT19	3.730-12	6.000	1.000	3.730	3.7240	3.6759	3.6685	3.6278	
DRT20	3.918-12	6.000	1.000	3.918	3.9120	3.8639	3.8565	3.8158	
DRT22	4.325-12	8.000	1.000	4.325	4.3190	4.2709	4.2626	4.2228	
DRT24	4.716-12	8.000	1.000	4.716	4.7050	4.6619	4.6536	4.6138	
DRT26	5.106-12	8.000	1.000	5.106	5.0950	5.0520	5.0440	5.0038	
DRT28	5.497-12	8.000	1.000	5.497	5.4860	5.4429	5.4346	5.3948	
DRT30	5.888-12	8.000	1.000	5.888	5.8770	5.8339	5.8256	5.7858	

Metric Rethreading Dies are also available (DRTM).

DRT SERIES RETHREADING DIES



NC SERIES

CLAMP NUT DIMENSIONS

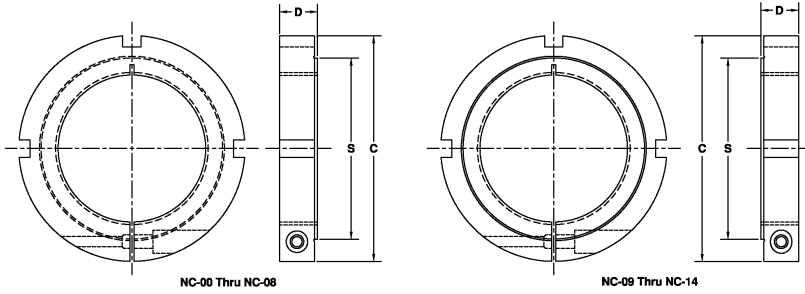

CLAMP NUT DIMENSIONS

CLAMP NUT NO.	SIZE	NO. PER INCH	THREADS MINOR DIA.		PITCH DIA.		OUTSIDE DIA. C	NUT WIDTH D	FACE DIA. S	CLAMP SCREW SIZE
			MIN.	MAX.	MIN.	MAX.				
NC-00	0.391	32	0.3572	0.3606	0.3707	0.3733	1.000	0.375	0.625	M3
NC-01	0.469	32	0.4352	0.4386	0.4487	0.4513	1.125	0.375	0.719	M3
NC-02	0.586	32	0.5522	0.5556	0.5657	0.5687	1.375	0.375	0.813	M4
NC-03	0.664	32	0.6302	0.6336	0.6437	0.6467	1.562	0.438	0.938	M5
NC-04	0.781	32	0.7472	0.7506	0.7607	0.7641	1.750	0.438	1.125	M5
NC-05	0.969	32	0.9352	0.9386	0.9487	0.9521	2.000	0.438	1.281	M5
NC-06	1.173	18	1.1129	1.1189	1.1369	1.1409	2.125	0.500	1.500	M5
NC-07	1.376	18	1.3159	1.3219	1.3399	1.3439	2.375	0.500	1.813	M5
NC-08	1.563	18	1.5029	1.5089	1.5263	1.5308	2.562	0.500	2.000	M5
NC-09	1.767	18	1.7069	1.7129	1.7309	1.7354	2.688	0.510	2.280	M6
NC-10	1.967	18	1.9069	1.9129	1.9309	1.9354	3.000	0.510	2.430	M6
NC-11	2.157	18	2.0969	2.1029	2.1209	2.1260	3.375	0.635	2.650	M8
NC-12	2.360	18	2.2999	2.3059	2.3239	2.3290	3.625	0.635	2.840	M8
NC-13	2.548	18	2.4879	2.4939	2.5119	2.5170	3.875	0.635	3.060	M8
NC-14	2.751	18	2.6909	2.6969	2.7149	2.7200	4.125	0.635	3.310	M8

Metric Clamp Nuts are also available.



NC SERIES CLAMP NUTS

X WASHERS

X-WASHERS and PINS DIMENSIONS

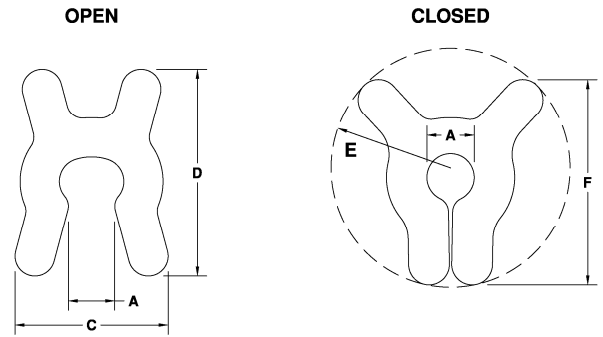

X WASHER DIMENSIONS

X WASHER NO.	ID		THICKNESS				
	A	B	C	D	E	F	
9000 5-4	0.086	0.025	0.320	0.406	0.210	0.406	
9000 6	0.098	0.055	0.364	0.490	0.297	0.475	
9000 8	0.130	0.055	0.430	0.575	0.359	0.556	
9000 10	0.164	0.065	0.523	0.687	0.422	0.665	
9000 12	0.190	0.065	0.593	0.745	0.437	0.730	
9000 14	0.222	0.075	0.622	0.776	0.469	0.775	
9000 16	0.256	0.075	0.698	0.905	0.500	0.890	
9000 18	0.285	0.075	0.822	0.986	0.563	0.984	
9000 20	0.317	0.089	0.872	1.100	0.609	1.078	
9000 22	0.347	0.089	0.948	1.190	0.688	1.188	
9000 24	0.381	0.089	1.060	1.297	0.797	1.281	

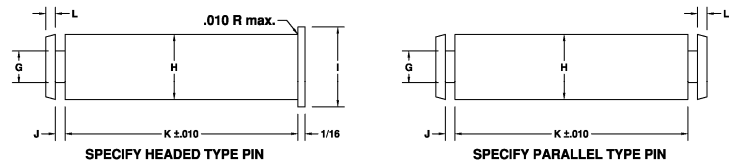

PIN DIMENSIONS

SIZE	+0.000/-0.005		+0.000/-0.004		+0.005/-0.000	
	G	H	I	J	L	
H-5	0.086	0.156	0.250	0.031	0.062	
H-6	0.093	0.187	0.312	0.062	0.062	
H-7	0.093	0.218	0.343	0.062	0.062	
H-8	0.125	0.250	0.375	0.062	0.062	
H-9	0.125	0.281	0.406	0.062	0.062	
H-10	0.156	0.312	0.437	0.075	0.062	
H-11	0.156	0.343	0.468	0.075	0.062	
H-12	0.187	0.375	0.500	0.075	0.062	
H-13	0.187	0.406	0.531	0.075	0.062	
H-14	0.218	0.437	0.562	0.083	0.062	
H-15	0.218	0.468	0.593	0.083	0.062	
H-16	0.250	0.500	0.625	0.083	0.062	
H-17	0.250	0.531	0.656	0.083	0.062	
H-18	0.279	0.562	0.687	0.083	0.093	
H-19	0.279	0.593	0.718	0.083	0.093	
H-20	0.311	0.625	0.750	0.097	0.093	
H-21	0.311	0.656	0.781	0.097	0.093	
H-22	0.341	0.687	0.812	0.097	0.093	
H-23	0.341	0.718	0.843	0.097	0.093	
H-24	0.375	0.750	0.875	0.097	0.093	
H-25	0.375	0.781	0.906	0.097	0.093	

NOTES:

X-WASHERS

Commercial tolerances

All X-Washers are zinc plated or plated to your specifications

PINS

When ordering, specify pin part number and effective length "K".

Pins plated to your specifications.

Special pin designs quoted at your request.

X-WASHERS



XTM WASHER RETAINER



STANDARD's X-WASHER provides manufacturing industries with a *simple, efficient, economical* fastener/retainer assembly. The X-WASHER functions as both a fastener and a washer; by virtue of its positive clinching operation, the X-WASHER is a versatile and strong fastener—in many cases providing sufficient axial strength to replace a *nut and washer*. The shear-resistant X-WASHER is stamped from cold rolled steel* (Spec. SAE 1010 or equiv.) and then cadmium or zinc plated.* STANDARD X-WASHERS hold production costs to a minimum by eliminating the two- and three-item

assembly required by traditional fasteners. Easily applied and quickly clamped to a positive 360° closure, the X-WASHER saves hours of assembly time; simple "one-two" installation, combined with STANDARD's positive clinching action eliminate costly production failures. The X-WASHER is applied to the grooved pin by hand and quickly clamped with pliers or automatic equipment. Removal lugs facilitate any necessary service or repairs. "Easy on...Strong positive closure...Easy off." X-WASHER sizes are readily available for pin diameters from 5/64 to 25/32 inch.

*SPECIAL MATERIAL OR PLATING QUOTED ON REQUEST



X-WASHERS



Contract Machining

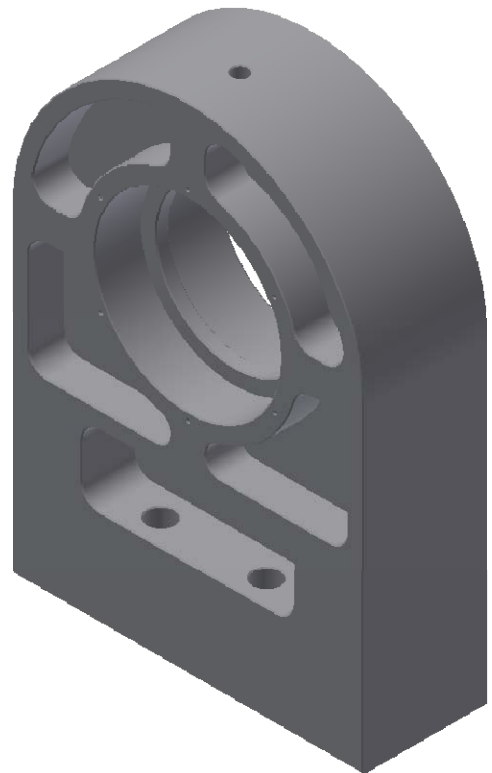

Contract Machining



Highest Quality Machined Products

Through our Quality, Engineering, and Manufacturing systems, we at Standard Locknut can produce products to your specific requirements and deliver on time.

Our core competency in CNC machining and secondary operations such as broaching, milling, drilling and tapping provide you with the highest quality part you expect through a team of highly skilled and dedicated associates.

Capabilities

- More than 80 CNC work centers for machining of forgings, castings, tubing, or bar stock
- CNC Machining (Milling, Drilling, and Threading) of parts in a 50" L x 26" W x 25" H envelope
- Turning of parts up to 52" in diameter
- Production capability for low or high production volumes
- Expedited deliveries available

Contact our Sales Department at sales@stdlocknut.com for a quote.

Or Call Customer Service at 800-783-6887

CONTRACT MACHINING

