



Catalog



Single-Phase Gearmotors DRK71 – DRK90, ET56, ER63



Table of contents

1	Introduction.....	6
1.1	The SEW-EURODRIVE group of companies	6
1.2	Products and systems from SEW-EURODRIVE.....	7
1.3	Documentation.....	10
1.4	Product names and trademarks.....	11
1.5	Copyright notice	11
2	Product description.....	12
2.1	Product features.....	12
2.2	Corrosion and surface protection.....	16
2.3	Extended storage.....	18
2.4	Condition monitoring: Oil aging sensor	20
2.5	Oil expansion tank	20
3	Overview of types and type designations	21
3.1	Variants and gear unit options	21
3.2	Designs and options of the DRK.. motor series	24
3.3	Designs and options of the ET56 and ER63 motors.....	26
3.4	Example type designation of a DRK.. gearmotor.....	27
3.5	DRK.. gearmotor nameplate	27
3.6	Gearmotor types	28
4	Project planning for drives	39
4.1	Additional publications	39
4.2	Drive and gear unit selection data	39
4.3	Project planning procedure for DR.. gearmotors	40
4.4	Project planning information – R, F, K, S, W gear units.....	41
4.5	Service factor	43
4.6	Overhung and axial loads	46
4.7	Project planning for RM gear units.....	50
5	Gear unit mounting positions and order information	53
5.1	General mounting position information – R, F, K, S, W gear units	53
5.2	Order information	54
5.3	Key to the mounting position sheets.....	59
5.4	Mounting position sheets	63
5.5	Mounting positions of AC motors	96
6	Design and operating notes	97
6.1	Lubricants	97
6.2	Gear unit venting.....	105
6.3	Reduced backlash gear unit design /R	106
6.4	Installation/removal of gear units with hollow shaft and key	107
6.5	Gear units with hollow shaft.....	112
6.6	TorqLOC® mounting system for gear units with hollow shaft	113
6.7	Shouldered hollow shaft option with shrink disk	115
6.8	Adapters for mounting IEC motors.....	122
6.9	Adapters for mounting NEMA motors	125

6.10	Gear unit mounting	127
6.11	Torque arms.....	128
6.12	Flange contours of RF.. and R..F gear units.....	130
6.13	Flange contours of FF., KF., SF.. and WF.. gear units	131
6.14	Flange contours of FAF., KAF., SAF.. and WAF.. gear units.....	133
6.15	Covers.....	135
6.16	Condition monitoring: Oil aging sensor	139
7	Important information on selection tables and dimension drawings.....	142
7.1	Possible geometrical combinations.....	142
7.2	Selection tables for gearmotors	143
7.3	Dimension sheet information	144
7.4	Gearmotor dimensions.....	147
8	Helical gearmotors	148
8.1	R..DRK.. designs	148
8.2	Possible geometrical combinations of R..DRK..	150
8.3	Selection tables R..DRK.. in kW	162
8.4	Dimension sheets R..DRK.. in mm	178
9	Parallel-shaft helical gearmotors	213
9.1	F..DRK.. designs.....	213
9.2	Possible geometrical combinations of F..DRK.....	215
9.3	Selection tables F..DRK.. in kW.....	223
9.4	Dimension sheets F..DRK.. in mm.....	230
10	Helical-bevel gearmotors	277
10.1	K..DRK.. designs.....	277
10.2	Possible geometrical combinations of K..DRK.....	280
10.3	Selection tables K..DRK.. in kW.....	289
10.4	Dimension sheets K..DRK.. in mm.....	298
11	Helical-worm gearmotors	360
11.1	S..DRK.. designs.....	360
11.2	Possible geometrical combinations of S..DRK.....	362
11.3	Selection tables S..DRK.. in kW.....	368
11.4	Dimension sheets S..DRK.. in mm.....	375
11.5	Technical data S. SF. SA. SAF 37.....	404
11.6	Technical data S. SF. SA. SAF 47.....	408
11.7	Technical data S. SF. SA. SAF 57.....	412
11.8	Technical data S. SF. SA. SAF 67.....	416
11.9	Technical data S. SF. SA. SAF 77.....	420
11.10	Technical data S. SF. SA. SAF 87.....	424
12	SPIROPLAN® gearmotors	428
12.1	W..DRK.. designs.....	428
12.2	Possible geometrical combinations of W..DRK.....	430
12.3	Selection tables W..DRK.. in kW.....	433
12.4	Dimension sheets W..DRK.. in mm.....	438

13	Technical data of the motors	458
13.1	Key to the data of energy-efficient motors	458
13.2	ET56 motor/brakemotor, 110 V, 60 Hz, 4-pole, S1	459
13.3	ET56 motor/brakemotor, 220 V, 60 Hz, 4-pole, S1	459
13.4	ET56 motor/brakemotor, 230 V, 50 Hz, 4-pole, S1	459
13.5	ET56 motor/brakemotor, 230 V, 60 Hz, 4-pole, S1	459
13.6	ER63 motors/brakemotors, 220 V, 50 Hz, 4-pole, S1	460
13.7	ER63 motors/brakemotors, 220 V, 60 Hz, 4-pole, S1	460
13.8	ER63 motors/brakemotors, 230 V, 50 Hz, 4-pole, S1	460
13.9	ER63 motors/brakemotors, 230 V, 60 Hz, 4-pole, S1	460
13.10	DRK.. motors/brakemotors, 220 V, 50 Hz, 4-pole, S1	461
13.11	DRK.. motors/brakemotors, 220 V, 60 Hz, 4-pole, S1	462
13.12	DRK.. motors/brakemotors, 230 V, 50 Hz, 4-pole, S1	463
13.13	DRK.. motors/brakemotors, 230 V, 60 Hz, 4-pole, S1	464
14	Address directory SEW-EURODRIVE	465
	Index	485
15	Order and inquiry form	489

1 Introduction

1.1 The SEW-EURODRIVE group of companies

1.1.1 Global presence

Driving the world – with innovative drive solutions for all industries and for every application. Products and systems from SEW-EURODRIVE are used all over the world. Be it in the automotive, building materials, food and beverage or metal-processing industry: The decision to use drive technology "made by SEW-EURODRIVE" stands for reliability for both functionality and investment.

We are represented in the most important branches of industry all over the world: with 14 manufacturing plants and 79 Drive Technology Centers worldwide as well as our customer support, which we consider an integrative service that continues our commitment to outstanding quality.

1.1.2 Always the right drive

The SEW-EURODRIVE modular concept offers millions of combinations. This wide selection enables you to choose the correct drive for all applications, each based on the required speed and torque range, available space, and ambient conditions. Gear units and gearmotors offering a unique and finely tuned performance range and the best economic prerequisites to meet your drive requirements.

The modular DR.. motor series includes the energy-efficient motor types IE1 to IE4 and was designed and constructed with all worldwide requirements for energy efficiency classes in mind. The DR.. motor easily meets the requirements for approval and certification in all relevant countries. The energy-efficient drives achieve the highest efficiency in combination with SEW-EURODRIVE gear units.

The gearmotors are electronically enhanced by MOVITRAC® frequency inverters, MOVIDRIVE® drive inverters, and MOVIAxis® multi-axis servo inverters – a combination that blends perfectly with the existing SEW-EURODRIVE program. As is the case with the mechanical systems, all development, production, and assembly is carried out entirely by SEW-EURODRIVE. In combination with our drive electronics, these drives provide the utmost in flexibility.

Products of the servo drive system, such as low backlash servo gear units, compact servomotors, or MOVIAxis® multi-axis servo inverters ensure precision and dynamics. From single-axis or multi-axis applications to synchronized process sequences, servo drive systems from SEW-EURODRIVE enable flexible and customized implementation of your applications.

For economical, decentralized installations, SEW-EURODRIVE offers components from its decentralized drive system, such as MOVIMOT®, the gearmotor with integrated frequency inverter, or MOVI-SWITCH®, the gearmotor with integrated switching and protection function. SEW-EURODRIVE has developed hybrid cables to provide cost-effective functional solutions, irrespective of the system philosophy or scope. The latest developments from SEW-EURODRIVE: DRC.. electronic motor, MOVIGEAR® mechatronic drive system, MOVIFIT® decentralized drive controller, MOVIPRO® decentralized drive, positioning, and application controller, as well as MOVITRANS® system components for contactless energy transfer.

Power, quality, and robustness combined in a single standard product: with SEW-EURODRIVE, powerful movements are delivered by industrial gear units with high torques. The modular concept once again ensures optimum adaptation of industrial gear units to meet a wide range of different applications.

1.1.3 Your ideal partner

Its global presence, extensive product range and broad spectrum of services make SEW-EURODRIVE the ideal partner for the machinery and plant construction industry when it comes to providing drive systems for demanding drive tasks in all industries and applications.

1.2 Products and systems from SEW-EURODRIVE

The products and systems by SEW-EURODRIVE are divided into the following product groups:

- Industrial gear units
- Gearmotors and frequency inverters
- Servo drive systems
- Decentralized drive systems
- MAXOLUTION®

Products and systems used in applications of several groups are listed in a separate group entitled "products and systems covering several product groups". The following tables indicate the products and systems included in the respective product group:

Industrial gear units
<ul style="list-style-type: none"> • X, MC, ML series helical and bevel-helical gear units • P002 – 102 series planetary gear units • XP130 – 250 series planetary gear units • P.X.. series planetary bevel-helical gear units • Application solutions with connections <ul style="list-style-type: none"> – Girth gears – Swing base – Gearmotor – Motor – Coupling – Brake – Lubrication system <p>For conveyor drives, bucket conveyors, agitators, cooling towers, crane systems, and much more</p>

Gearmotors and frequency inverters		
Gear units / gearmotors	Motors	Frequency inverters
<ul style="list-style-type: none"> • Helical gear units / helical gearmotors • Parallel-shaft helical gear units / parallel-shaft helical gearmotors • Helical-bevel gear units / gearmotors • Helical-worm gear units / helical-worm gearmotors • SPIROPLAN® right-angle gearmotors • EMS drives • Geared torque motors • Pole-changing gearmotors • Variable-speed gear units / variable-speed gearmotors • Aseptic gearmotors • Explosion-proof gear units / gearmotors • Explosion-proof variable-speed gear units / variable-speed gearmotors 	<ul style="list-style-type: none"> • Asynchronous AC motors / AC brakemotors • Pole-changing AC motors / AC brakemotors • Energy-efficient motors • Explosion-proof AC motors / AC brakemotors • Torque motors • Single-phase motors / single-phase brakemotors • Asynchronous linear motors 	<ul style="list-style-type: none"> • MOVITRAC® frequency inverters • MOVI4R-U® frequency inverters • MOVIDRIVE® drive inverters • Control, technology and communication options for inverters
Servo drive systems		
Servo gear units / gearmotors	Servomotors	Servo drive inverters / servo inverters
<ul style="list-style-type: none"> • Low backlash planetary servo gear units / planetary gearmotors • Low backlash helical-bevel servo gear units / helical-bevel gear units • R, F, K, S, W gear units / gearmotors • Explosion-proof servo gear units / servo gearmotors 	<ul style="list-style-type: none"> • Asynchronous servomotors / servo brakemotors • Synchronous servomotors / servo brakemotors • Explosion-proof servomotors / servo brakemotors • Synchronous linear motors 	<ul style="list-style-type: none"> • MOVIDRIVE® servo drive inverters • MOVIAXIS® multi-axis servo inverter • Control, technology and communication options for servo drive inverters and servo inverters

Decentralized drive systems		
Decentralized drives	Communication and installation	Contactless energy transfer
<ul style="list-style-type: none"> • DRC.. electronic motors / MOVIGEAR® mechatronic drive systems <ul style="list-style-type: none"> – DBC – Direct Binary Communication – DAC – Direct AS-Interface Communication – DSC – Direct SBus Communication – SNI – Single Line Network Installation • MOVIMOT® gearmotors with integrated frequency inverter • MOVIMOT® motors / brakemotors with integrated frequency inverter • MOVI-SWITCH® gearmotors with integrated switching and protection functions • MOVI-SWITCH® motors / brakemotors with integrated switching and protection function • Explosion-proof MOVIMOT® and MOVI-SWITCH® gearmotors 	<ul style="list-style-type: none"> • Fieldbus interfaces • Field distributors for decentralized installation • MOVIFIT® product range <ul style="list-style-type: none"> – MOVIFIT® FDC for controlling MOVIGEAR® and DRC.. drive units – MOVIFIT® MC for controlling MOVIMOT® drives – MOVIFIT® SC with integrated electronic motor switch – MOVIFIT® FC with integrated frequency inverter • MOVIPRO® product range <ul style="list-style-type: none"> – MOVIPRO® SDC decentralized drive and positioning control 	<ul style="list-style-type: none"> • MOVITRANS® system <ul style="list-style-type: none"> – Stationary components for energy supply – Mobile components for energy consumption – Line cables and installation material

MAXOLUTION®

- MAXOLUTION® packages for predefined application solutions
- MAXOLUTION® systems for customer-specific system solutions and plants

Products and systems covering several product groups

- Operator panels
- MOVI-PLC® drive-based control system
- Components of the type "functional safety"
- Diagnostic units

In addition to its products and systems, SEW-EURODRIVE offers a comprehensive range of services. These include:

- Technical consulting
- User software
- Seminars and training
- Extensive technical documentation
- Worldwide customer service

Visit our website at

→ www.sew-eurodrive.com

The website provides comprehensive information and services.

1.3 Documentation

1.3.1 Contents of this publication

This "Single-Phase Gearmotors" catalog provides a detailed description of the following product groups from SEW-EURODRIVE:

- DRK.., ET56.. and ER63.. helical gearmotors
- DRK.., ET56.. and ER63.. parallel-shaft helical gearmotors
- DRK.., ET56.. and ER63.. helical-bevel gearmotors
- DRK.., ET56.. and ER63.. helical-worm gearmotors
- DRK.., ET56.. and ER63.. SPIROPLAN® gearmotors

1.3.2 Additional documentation

In addition to this "Single-Phase Gearmotors" catalog, you can order or download other documents from the SEW-EURODRIVE homepage. The complete range of technical documentation is available in various languages for download from the web at www.sew-eurodrive.com.

Catalogs

- Gear units
- Servo gear units
- AC motors
- DRS.. gearmotors (IE1)
- DRE.. gearmotors (IE2)
- DRN.. Gearmotors (IE3)
- Synchronous servomotors
- Synchronous servo gearmotors
- Asynchronous servo gearmotors
- DRC.. gearmotors
- Variable-speed gearmotors
- Pole-changing gearmotors
- Geared torque motors
- Explosion-proof drives
- Explosion-proof AC motors

Drive Engineering – Practical Implementation

You find detailed information on the entire topic of electrical drive engineering in the publications of the "Drive Engineering - Practical Implementation" series:

- Project planning for drives

- EMC in Drive Engineering – Basic Theoretical Principles and EMC-Compliant Installation in Practice
- Efficient Plant Automation with Mechatronic Drive Solutions
- SEW Encoder Systems
- Servo Technology
- Explosion-Proof Drives to EU Directive 94/9/EC

1.4 Product names and trademarks

All product names included in this documentation are trademarks or registered trademarks of the respective titleholders.

1.5 Copyright notice

© 2015 SEW-EURODRIVE. All rights reserved.

Unauthorized reproduction, modification, distribution or any other use of the whole or any part of this documentation is strictly prohibited.

2 Product description

2.1 Product features

2.1.1 DRK.. single-phase motor

The single-phase motors from the modular motor system of the DR.. series are designed for operation in 1-phase supply systems. They can be operated in supply systems of 220 V or 230 V at 50 Hz or 60 Hz. The required rotating field is created with the neutral conductor as 2nd phase and the installed capacitor as 3rd phase.

Apart from the DRK71.. – DRK90.. motors, SEW-EURODRIVE offers the ET56 and ER63 single-phase motors for the low power range.

ET56 and DRK.. motors are supplied with running capacitor for Europe and Brazil with IEC and ABNT design specification. For the DRK.. motor, the capacitor is installed and wired in the terminal box.

2.1.2 Operating temperatures

Gear units and gearmotors from SEW-EURODRIVE can be operated in a wide ambient temperature range.

Gear unit

The following standard temperature ranges are permitted for filling the gear units according to the lubricant table:

Gear unit	Filled with	Permitted standard temperature range
K..19, K..29, K..39, K..49	CLP(PG) VG460	-20 °C to +60 °C
K..37, K..47, K..57 – K..187 RX.57 – RX.107 R.07 – R.167 F..27 – F..157	CLP(CC) VG220	-15 °C to +40 °C
S..37 – S..97	CLP(CC) VG680	0 °C to +40 °C
W..10 – W..30 W..37, W..47	CLP(SEW-PG) VG460	-20 °C to +40 °C

The rated data of the gear units and gearmotors specified in the catalog refer to an ambient temperature of +25 °C.

Gear units from SEW-EURODRIVE can be operated outside the standard temperature range if project planning is adapted to ambient temperatures from as low as up to -40 °C in the intensive cooling range until up to +60 °C. Project planning must take special operating conditions into account and adapt the drive to the ambient conditions by selecting suitable lubricants and seals.

This kind of project planning is generally recommended for increased ambient temperatures as of size 97 and for helical-worm gear units with small gear ratios. SEW-EURODRIVE will gladly carry out this project planning for you.

Motors

The single-phase motors are designed for use in a temperature range between -20 °C and +40 °C.

2.1.3 Installation altitude

Due to the low air density at high installation altitudes, heat dissipation on the surface of motors and gear units decreases. The rated data listed in the catalog applies to an installation altitude of maximum 1000 m above sea level. Installation altitudes > 1000 m asl must be taken into account for project planning of gear units and gearmotors.

2.1.4 Power and torque

The power and torque ratings refer to mounting position M1 and similar mounting positions in which the input stage is not completely submerged in oil. In addition, the gearmotors are assumed to be standard versions with standard lubrication and under normal ambient conditions.

2.1.5 Speeds

The quoted output speeds of the gearmotors are recommended values. You can calculate the rated output speed based on the rated motor speed and the gear unit reduction ratio. Please note that the actual output speed depends on the motor load and the supply system conditions.

2.1.6 Noise

The noise levels of all SEW-EURODRIVE gear units, motors and gearmotors are well within the maximum permitted noise levels set forth in the VDI guideline 2159 for gear units and IEC/EN 60034 for motors.

2.1.7 Painting

The gear units, motors and gearmotors from SEW-EURODRIVE are painted as follows:

Gear unit	Painting according to standard 1843
R, F, K, S, W gear units	blue/gray RAL 7031

Exception: SPIROPLAN® W..10ET56 gearmotors have an aluminum housing and are supplied unpainted as standard.

Special paints are available on request.

2.1.8 Heat dissipation and accessibility

Make sure to maintain adequate distance from heat-sensitive components when installing gearmotors/geared brakemotors to the driven machine. The space is required for heat dissipation via air circulation and for maintenance work on the brake.

2.1.9 Weights

Please note that all weight specifications in the catalogs apply to gear units and gearmotors without lubricant. The weights vary according to gear unit design and gear unit size. The lubricant fill depends on the mounting position selected, which means that in this case no universally applicable information can be given. Guide values for lubricant fill quantities based on the mounting position are provided in the chapter "Lubricant fill quantities" (→ 100). The exact weight is given in the order confirmation.

2.1.10 RM gear units, RM gearmotors

RM gear units and RM gearmotors are a special type of helical gear units with an extended output bearing hub. They were designed especially for agitating applications and allow for high overhung and axial loads and bending moments. The other data are the same as for standard helical gear units and standard helical gearmotors. You can find special project planning notes for RM gear units in the chapter "Project planning for RM gear units" (→ 50).

2.1.11 SPIROPLAN® gearmotors

SPIROPLAN® gearmotors are robust, single- and two-stage right-angle gearmotors with SPIROPLAN® gearing. They have three main differences from the helical-worm gear units: the material combination of the steel-on-steel gearing, the special tooth meshing relations and the aluminum housing. As a result, SPIROPLAN® right-angle gearmotors are wear-free and lightweight.

The particularly short design and the aluminum housing make for very compact and lightweight drive solutions.

The wear-free gearing and the life-long lubrication facilitate long periods of maintenance-free operation. The identical hole spacing and axle height of the foot and face allows for a number of mounting options.

Two different flange diameters are available. On request, SPIROPLAN® gearmotors can be equipped with a torque arm.

2.1.12 Brakemotors

On request, motors and gearmotors can be supplied with an integrated mechanical brake. The SEW-EURODRIVE brake is an electromagnetic disk brake with a DC coil that releases electrically and brakes using spring force. Due to its operating principle, the brake is applied if the power fails. It meets the basic safety requirements. The brake can also be released mechanically if equipped with manual brake release. For this purpose, the brake comes with either a hand lever with automatic reset or an adjustable setscrew. The brake is controlled with a brake control that is either installed in the motor wiring space or the control cabinet.

A characteristic feature of the brakes is their very short design. The brake bearing endshield is a part of both the motor and the brake. The integrated construction of the SEW-EURODRIVE brakemotor permits particularly compact and robust solutions.

2.1.13 International markets

USA and Canada



On request, SEW-EURODRIVE supplies UL registered motors or CSA certified motors with connection conditions according to CSA and NEMA standard.

Eurasian Economic Union / Customs Union between Russia, Belarus, and Kazakhstan.



Motors marketed in Russia, Belarus or Kazakhstan after March 15th, 2015 must bear the EAC mark (Eurasian Conformity), similar to the European CE mark.

Similar to the CE mark, manufacturers and suppliers use the EAC mark to confirm that a product has undergone a conformity process and meets the specified technical requirements. Conformity is issued by an authorized certifying body. The requirements for the conformity evaluation procedure are set forth in the technical regulations of the Customs Union (TR CU). These regulations refer to standards that must be applied for a manufacturer to meet the requirements. SEW-EURODRIVE motors meet the requirements of the technical regulations of the customs union for low-voltage systems. Contact your sales representative to assist you in such cases.

2.1.14 Components on the input side

The following components on the input side are available for the gear units from SEW-EURODRIVE:

- **Input shaft assembly with input shaft end**, optionally with
 - Centering shoulder
 - Backstop
 - Motor platform
- **Adapter**
 - For mounting IEC or NEMA motors with the option of a backstop
 - For mounting servomotors with a square flange
 - With torque limiting safety couplings and speed or slip monitor
 - With hydraulic start-up coupling, also available with disk brake or backstop

2.2 Corrosion and surface protection

2.2.1 General information

For motor and gear unit operation in aggressive environments, SEW-EURODRIVE optionally offers the following preventive measure:

- KS corrosion protection for motors
- Surface protection OS for motors and gear units

For motors, optimum protection is offered by a combination of KS corrosion protection and OS surface protection.

Optional preventive measures are also available for the output shafts.

2.2.2 KS corrosion protection



KS corrosion protection for motors comprises the following measures:

- All retaining screws that are loosened during operation are made of stainless steel.
- The nameplates are made of stainless steel.
- Various motor parts are coated with a finishing varnish.
- The flange contact surfaces and shaft ends are treated with a temporary rust preventive.
- For brakemotors, additional measures are performed.

A sticker labeled "KORROSIONSSCHUTZ" (corrosion protection) on the fan guard indicates that special treatment has been applied.

2.2.3 OS surface protection

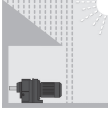
In addition to the standard surface protection, gearmotors with single-phase motor are also available with surface protection OS1 to OS2. The special measure "Z" is also available in addition. Special measure "Z" means that large contour recesses are filled with rubber before painting.

Surface protection ^{1) 2)}	Ambient conditions	Sample applications
Standard 	Suitable for machines and systems within buildings and interior rooms with neutral atmospheres. Similar to corrosivity category ³⁾ : • C1 (negligible)	<ul style="list-style-type: none"> • Machines and systems in the automobile industry • Transport systems in logistics • Conveyor belts at airports
OS1 	Suited for environments prone to condensation and atmospheres with low humidity or contamination, such as applications outdoors under roof or with protection device. According to corrosivity category ³⁾ : • C2 (low)	<ul style="list-style-type: none"> • Systems in saw mills • Hall gates • Agitators and mixers
OS2 	Suitable for environments with high humidity or mean atmospheric contamination, such as applications outdoors subject to direct weathering. According to corrosivity category ³⁾ : • C3 (moderate)	<ul style="list-style-type: none"> • Applications in amusement parks • Funiculars and chair-lifts • Applications in gravel plants • Systems in nuclear power plants

1) Motors/brakemotors in degree of protection IP56 or IP66 are only available with OS2 surface protection.
2) Gearmotors with OS2 surface protection are only offered in combination with KS corrosion protection.
3) According to DIN EN ISO 12944-2, classification of ambient conditions

2.2.4 Special protection measures

Gearmotor output shafts can be treated with special optional protective measures for operation subject to severe environmental pollution or in particularly demanding applications.

Measure	Protection principle	Suitable for:
FKM oil seal	High quality material	Drives subject to chemical contamination
Coating on output shaft end	Surface coating of the contact surface of the oil seal	Severe environmental impact and in conjunction with FKM oil seal
Stainless steel output shaft	Surface protection due to high-quality material	Particularly demanding applications in terms of surface protection

2.2.5 NOCO® fluid

As standard, SEW-EURODRIVE supplies NOCO® fluid corrosion protection and lubricant with every hollow shaft gear unit. Use NOCO® fluid when installing hollow shaft gear units. Using this fluid helps prevent contact corrosion and makes it easier to disassemble the drive at a later time. NOCO® fluid is also suitable for protecting machined metal surfaces that do not have corrosion protection, such as parts of shaft ends or flanges. You can also order NOCO® fluid in larger quantities from SEW-EURODRIVE.

Batch size	Packaging type	Part number
5.5 g	Sachet	09107819
100 g	Tube	03253147
1 kg	Tub	09107827

NOCO® fluid is a food grade substance according to NSF-H1. The food-grade NOCO® fluid has a corresponding NSF-H1 label on the packaging.

2.3 Extended storage

2.3.1 Realization

You can also order gear units designed for "extended storage". SEW-EURODRIVE recommends the extended storage type for storage periods longer than 9 months.

The lubricant of gear units for extended storage is mixed with a VCI anti-corrosion agent (volatile corrosion inhibitors). Please note that this VCI anti-corrosion agent is only effective in a temperature range of -25 °C to +50 °C. The flange contact surfaces and shaft ends are also treated with an anti-corrosion agent. If not specified otherwise in your order, the gear unit with "extended storage" option will be supplied with OS1 surface protection. You can order OS2 instead of OS1 if required.

INFORMATION



The gear units must remain tightly sealed until taken into operation to prevent the VCI anti-corrosion agent from evaporating.

The gear units come with the oil fill according to the specified mounting position (M1 – M6). Always check the oil level before you take the gear unit into operation.

2.3.2 Storage conditions

Observe the storage conditions specified in the following table for extended storage:

Climate zone	Packaging ¹⁾	Storage ²⁾	Storage duration
Temperate (Europe, USA, Canada, China and Russia, excluding tropical zones)	<ul style="list-style-type: none"> Packed in containers With desiccant and moisture indicator sealed in the plastic wrap 	<ul style="list-style-type: none"> Roofed Protected against rain and snow Shock-free 	Up to 3 years with regular checks of the packaging and moisture indicator (rel. humidity < 50%)
	Open	<ul style="list-style-type: none"> Under roof and enclosed at constant temperature and atmospheric humidity (5 °C < ϑ < 50 °C, < 50% relative humidity) No sudden temperature variations Controlled ventilation with filter (free from dust and dirt) No aggressive vapors No shocks 	2 years or more with regular inspections <ul style="list-style-type: none"> Check for cleanness and mechanical damage during the inspection Check corrosion protection
Tropical (Asia, Africa, Central and South America, Australia, New Zealand excluding temperate zones)	<ul style="list-style-type: none"> Packed in containers With desiccant and moisture indicator sealed in the plastic wrap Protected against insect damage and mildew by chemical treatment 	<ul style="list-style-type: none"> Roofed Protected against rain and snow Shock-free 	Up to 3 years with regular checks of the packaging and moisture indicator (rel. humidity < 50%)
	Open	<ul style="list-style-type: none"> Under roof and enclosed at constant temperature and atmospheric humidity (5 °C < ϑ < 50 °C, < 50% relative humidity) No sudden temperature variations Controlled ventilation with filter (free from dust and dirt) No aggressive vapors No shocks Protected against insect damage 	2 years or more with regular inspections <ul style="list-style-type: none"> Check for cleanness and mechanical damage during the inspection Check corrosion protection

1) The packaging must be carried out by an experienced company using the packaging materials that have been explicitly specified for the particular application.

2) SEW-EURODRIVE recommends to store the gear units according to the mounting position.

2.4 Condition monitoring: Oil aging sensor

2.4.1 DUO10A diagnostic unit

The diagnostic unit consists of a temperature sensor and the actual evaluation unit. The service life curves of the oil grades common in SEW-EURODRIVE gear units are stored in the evaluation unit. SEW-EURODRIVE can customize any oil grade in the diagnostic unit. Standard parameterization is performed directly on the evaluation unit. During operation, the evaluation unit uses the oil temperature to continuously calculate the remaining service life in days until the next oil change. The remaining service life is displayed directly on the evaluation unit. When the service life is expired, a binary signal can be sent to a higher-level system and evaluated or visualized in the system.

Using the DUO10A diagnostic unit, the system operator no longer has to replace the oil within predefined intervals, but can adapt the replacement interval individually to the actual load. The benefits are reduced maintenance and service costs, and increased system availability.

2.5 Oil expansion tank

The oil expansion tank allows the lubricant or air space of the gear unit to expand. This means no lubricant can escape the breather valve at high operating temperatures.

SEW-EURODRIVE recommends to use oil expansion tanks for gear units and gearmotors in M4 mounting position and for input speeds $> 2000 \text{ min}^{-1}$.

The following figure shows the oil expansion tank of a gearmotor.

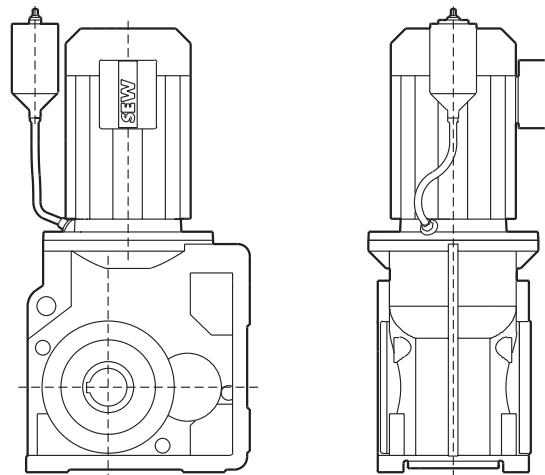

4979181323

The oil expansion tank is delivered as assembly kit for mounting onto the gearmotor. In case of limited space or of gear units without motor, the oil expansion tank can also be mounted to nearby machine parts.

For further information, contact your SEW-EURODRIVE sales representative.

3 Overview of types and type designations

3.1 Variants and gear unit options

Below an overview of type designations for R, F, K, S, and W gear units and their options.

3.1.1 Helical gear units

Designation	Description
RX..	Single-stage foot-mounted design
RXF..	Single-stage B5 flange-mounted design
R..	Foot-mounted design
R..F	Foot-mounted and B5 flange-mounted design
RF..	B5 flange-mounted design
RZ..	B14 flange-mounted design
RM..	B5 flange-mounted design with extended bearing hub

3.1.2 Parallel-shaft helical gear units

Designation	Description
F..	Foot-mounted design
FA..B	Foot-mounted design and hollow shaft
FH..B	Foot-mounted design and hollow shaft with shrink disk
FV..B	Foot-mounted design and splined hollow shaft to DIN 5480
FF..	B5 flange-mounted design
FAF..	B5 flange-mounted design and hollow shaft
FHF..	B5 flange-mounted design and hollow shaft with shrink disk
FVF..	B5 flange-mounted design and hollow shaft with splined hollow shaft to DIN 5480
FA..	Hollow shaft
FH..	Hollow shaft with shrink disk
FT..	Hollow shaft with TorqLOC® hollow shaft mounting system
FV..	Splined hollow shaft to DIN 5480
FZ..	B14 flange-mounted design
FAZ..	B14 flange-mounted design and hollow shaft
FHZ..	B14 flange-mounted design and hollow shaft with shrink disk
FVZ..	B14 flange-mounted design and hollow shaft with splined hollow shaft to DIN 5480

3.1.3 Helical-bevel gear units

Designation	
K..	Foot-mounted design
KA..B	Foot-mounted design and hollow shaft
KAF..B	B5 flange-mounted design, hollow shaft and foot-mounted design
KF..B	Foot-mounted design, B5 flange-mounted design
KH..B	Foot-mounted design and hollow shaft with shrink disk
KHF..B	B5 flange-mounted design and hollow shaft with shrink disk and foot-mounted design
KV..B	Foot-mounted design and hollow shaft with splined hollow shaft to DIN 5480
KF..	B5 flange-mounted design
KAF..	B5 flange-mounted design and hollow shaft
KHF..	B5 flange-mounted design and hollow shaft with shrink disk
KVF..	B5 flange-mounted design and hollow shaft with splined hollow shaft to DIN 5480
KA..	Hollow shaft
KH..	Hollow shaft with shrink disk
KT..	Hollow shaft with TorqLOC® hollow shaft mounting system
KV..	Splined hollow shaft according DIN 5480
KZ..	B14 flange-mounted design
KAZ..	B14 flange-mounted design and hollow shaft
KHZ..	B14 flange-mounted design and hollow shaft with shrink disk
KVZ..	B14 flange-mounted design and hollow shaft with splined hollow shaft to DIN 5480

3.1.4 Helical-worm gear units

Designation	Description
S..	Foot-mounted design
SF..	B5 flange-mounted design
SAF..	B5 flange-mounted design and hollow shaft
SHF..	B5 flange-mounted design and hollow shaft with shrink disk
SA..	Hollow shaft
SH..	Hollow shaft with shrink disk
ST..	Hollow shaft with TorqLOC® hollow shaft mounting system
SAZ..	B14 flange-mounted design and hollow shaft
SHZ..	B14 flange-mounted design and hollow shaft with shrink disk

3.1.5 SPIROPLAN® gear units

Designation	Description
W..	Foot-mounted design
WF..	B5 flange-mounted design
WAF..	B5 flange-mounted design and hollow shaft
WA..	Hollow shaft
WA..B	Foot-mounted design and hollow shaft
WH..B	Foot-mounted design and hollow shaft with shrink disk
WHF..	B5 flange-mounted design and hollow shaft with shrink disk
WH..	Hollow shaft with shrink disk
WT..	Hollow shaft with TorqLOC® hollow shaft mounting system

3.1.6 Options

R, F and K gear units:

Designation	Description
/R	Reduced backlash

K, S and W gear units:

Designation	Description
/T	With torque arm

F gear units:

Designation	Description
/G	With rubber buffer

3.1.7 Condition monitoring

Designation	Description
/DUO	Diagnostic Unit Oil = Oil aging sensor

3 Overview of types and type designations

Designs and options of the DRK.. motor series

3.2 Designs and options of the DRK.. motor series

The following sections show the options and type designations of single-phase motors.

3.2.1 Designation of the motors

Design	Description
DRK..	Single-phase motors with running capacitor
71 – 90	Sizes: 71 / 80 / 90
S, M, L	Lengths: S = short / M = medium / L = long
4	Number of poles

3.2.2 Output variants

Designation	Option
/FI	IEC foot-mounted motor
/FF	IEC flange-mounted motor with bore
/FT	IEC flange-mounted motor with threads
/FE	IEC flange-mounted motor with bore and IEC feet
/FY	IEC flange-mounted motor with threads and IEC feet
/FL	General flange-mounted motor (other than IEC)
/FK	General flange-mounted motor (deviating from IEC) with feet
/FG	SEW-EURODRIVE integral motor as stand-alone motor
/FM	SEW-EURODRIVE integral motor with IEC feet
/FC	C-face flange-mounted motor, dimensions in inch

3.2.3 Mechanical attachments

Designation	Option
BE..	Spring-loaded brake with specification of size
HR	Manual brake release of the brake, automatic re-engaging function
HF	Manual brake release, lockable

Designation	Option
/RS	Backstop

20272545/EN – 11/2015

3.2.4 Temperature sensor / temperature detection

Designation	Option
/TF	Temperature sensor (PTC thermistor or PTC resistor)
/TH	Thermostat (bimetallic switch)

3.2.5 Encoders

Option	Description
/EI7C	Built-in speed sensor with HTL interface
/EI76 /EI72 /EI71	Built-in speed sensor with HTL interface and 6/2/1 period(s)

3.2.6 Ventilation

Designation	Option
/V	Forced cooling fan
/Z	Additional inertia (flywheel fan)
/AL	Metal fan
/C	Canopy for the fan guard
/LN	Low-noise fan guard (for DR.71 – 132)

3.2.7 Condition monitoring

Designation	Option
/DUB1	Diagnostic unit brake 1 = Brake monitoring function monitoring
/DUB2	Diagnostic unit brake 2 = Brake monitoring wear monitoring
/DUB3	Diagnostic unit brake 3 = Brake monitoring function and wear monitoring

3 Overview of types and type designations

Designs and options of the ET56 and ER63 motors

3.3 Designs and options of the ET56 and ER63 motors

The following sections show the options of the ET56 and ER63 single-phase motors.

3.3.1 Designation and options of the ET56 motors

Design	Description
ET..	Single-phase motors with running capacitor
56	Size
L	Frame length: L = Long
4	Number of poles
Brake	Description
BMG02	Spring-loaded brake BMG of size 02

3.3.2 Designation and options of the ER63 motors

Design	Description
ER..	Single-phase motors with running capacitor
63	Size
L	Lengths: S = short / M = medium / L = long
4	Number of poles
Brake	Description
BR03	Spring-loaded brake BR of size 03

20272545/EN – 11/2015

3.4 Example type designation of a DRK.. gearmotor

The type designation of the gearmotor starts from the component on the output end. For example, a DRK.. gearmotor with temperature sensor in the motor winding has the following type designation:

Example: K77DRK90L4/TF		
Gear unit type	K	Gear unit
Gear unit size	77	
Motor series	DRK	Motor
Motor size	90	
Length	L	
Number of poles	4	
Motor option temperature sensor	/TF	Option

Example: DRK.. gearmotor

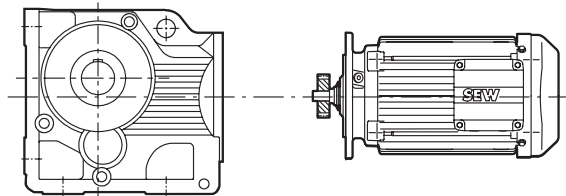

K77

DRK90L4/TF

12586003595

3.5 DRK.. gearmotor nameplate

The following figure shows an example of the nameplate of a DRK.. gearmotor.

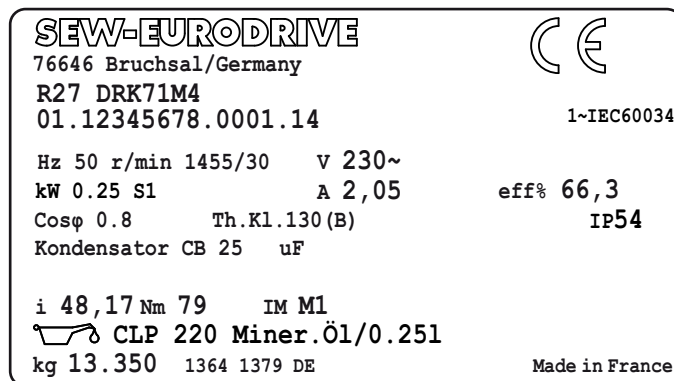

12611779083

3 Overview of types and type designations

Gearmotor types

3.6 Gearmotor types

INFORMATION



The variants described in this chapter refer to DR.. gearmotors from SEW-EURODRIVE. They also apply to gear units without motors.

3.6.1 Helical gearmotors

The following designs of helical gearmotors are available:

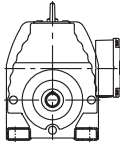
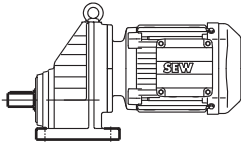

RX..DR..

Single-stage, helical gearmotor in foot-mounted design

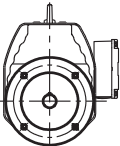
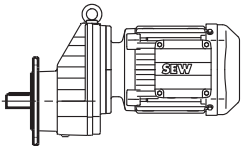

RXF..DR..

Single-stage helical gearmotor in B5 flange-mounted design

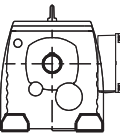
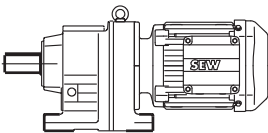

R..DR..

Helical gearmotor in foot-mounted design

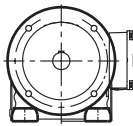
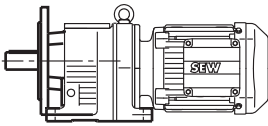

R..F DR..

Helical gearmotor in foot-mounted and B5 flange-mounted design

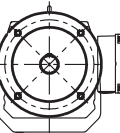
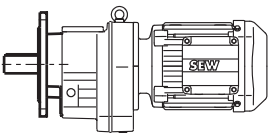

RF..DR..

Helical gearmotor in B5 flange-mounted design

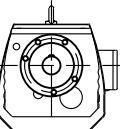
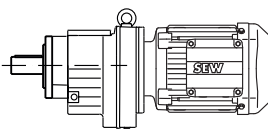

RZ..DR..

Helical gearmotor in B14 flange-mounted design

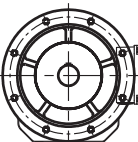
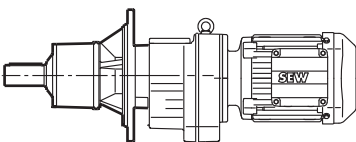

RM..DR..

Helical gearmotor in B5 flange-mounted design with extended bearing hub

3.6.2 Parallel-shaft helical gearmotors

The following types of parallel-shaft helical gearmotors are available:

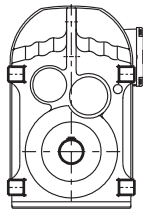
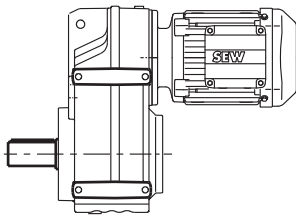

F..DR..

Parallel-shaft helical gearmotor in foot-mounted design

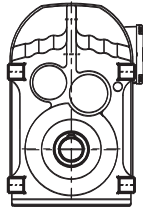
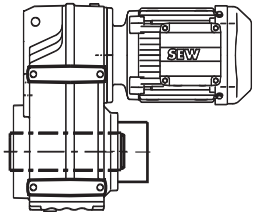

FA..B DR..

Parallel-shaft helical gearmotor in foot-mounted design with hollow shaft

FV..B DR..

Parallel-shaft helical gearmotor in foot-mounted design with splined hollow shaft to DIN 5480

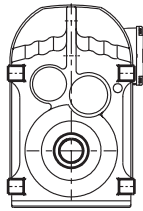
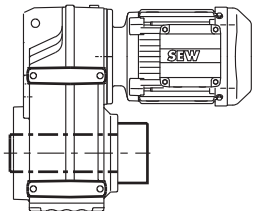

FH..B DR..

Parallel-shaft helical gearmotor in foot-mounted design with hollow shaft and shrink disk

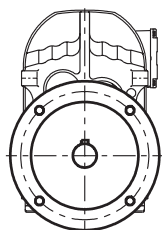
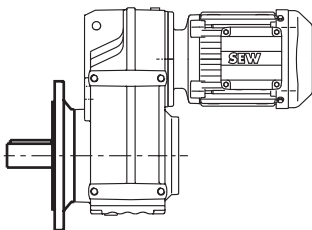

FF..DR..

Parallel-shaft helical gearmotor in B5 flange-mounted design

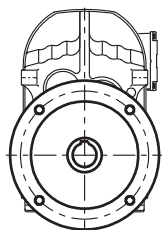
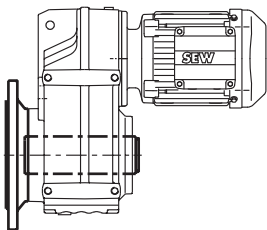

FAF..DR..

Parallel-shaft helical gearmotor in B5 flange-mounted design with hollow shaft

FVF..DR..

Parallel-shaft helical gearmotor in B5 flange-mounted design with splined hollow shaft to DIN 5480

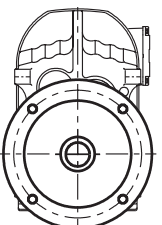
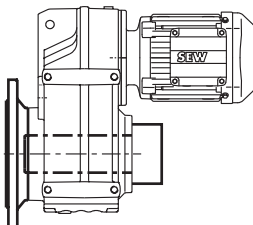

FHF..DR..

Parallel-shaft helical gearmotor in B5 flange-mounted design with hollow shaft and shrink disk

20272545/EN – 11/2015

3 Overview of types and type designations

Gearmotor types

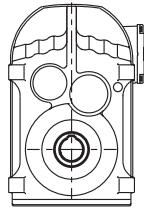
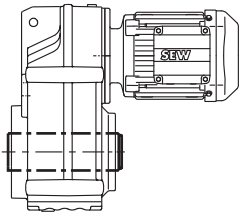

FA..DR..

Parallel-shaft helical gearmotor with hollow shaft

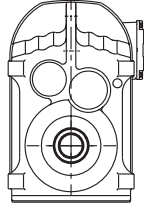
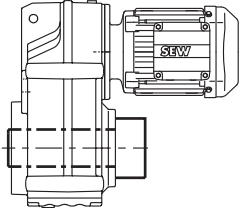

FV..DR..

Parallel-shaft helical gearmotor with splined hollow shaft to DIN 5480

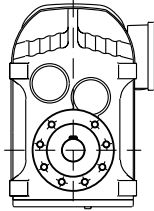
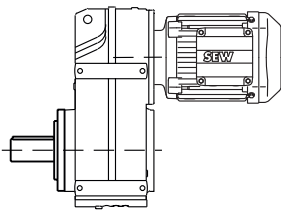

FH..DR..

Parallel-shaft helical gearmotor with hollow shaft and shrink disk

FT..DR..

Parallel-shaft helical gearmotor with hollow shaft and TorqLOC® hollow shaft mounting system

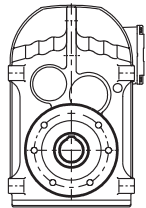
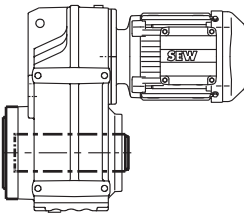

FZ..DR..

Parallel-shaft helical gearmotor in B14 flange-mounted design

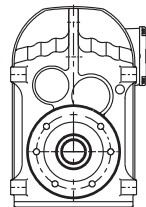
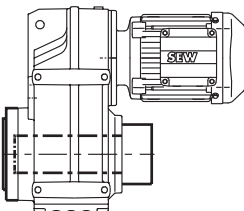

FAZ..DR..

Parallel-shaft helical gearmotor in B14 flange-mounted design with hollow shaft

FVZ..DR..

Parallel-shaft helical gearmotor in B14 flange-mounted design with splined hollow shaft to DIN 5480



FHZ..DR..

Parallel-shaft helical gearmotor in B14 flange-mounted design with hollow shaft and shrink disk

3.6.3 Helical-bevel gearmotors, gear unit sizes K..19 and K..29

The following designs of helical-bevel gearmotors with gear units of size K..19 and K..29 are available:

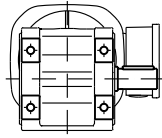
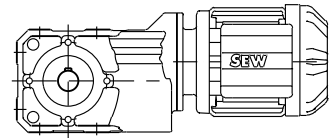

K19 DR., K29 DR..

Helical-bevel gearmotor in foot-mounted design

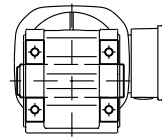
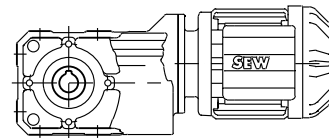

KA19B DR., KA29B DR..

Helical-bevel gearmotor in foot-mounted design with hollow shaft in foot-mounted design

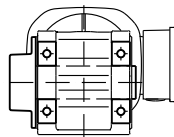
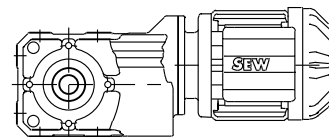

KH19B DR., KH29B DR..

Helical-bevel gearmotor in foot-mounted design with hollow shaft and shrink disk

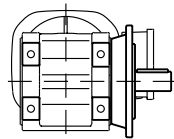
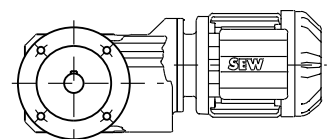

KF19B DR., KF29B DR..

Helical-bevel gearmotor in B5 flange-mounted design in foot-mounted design

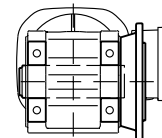
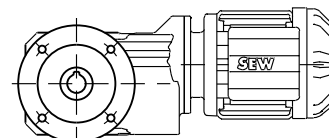

KAF19B DR., KAF29B DR..

Helical-bevel gearmotor in B5 flange-mounted design with hollow shaft in foot-mounted design

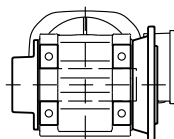
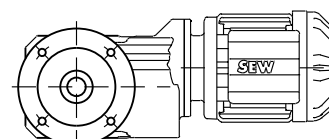

KHF19B DR., KHF29B DR..

Helical-bevel gearmotor with B5 flange-mounted design with hollow shaft and shrink disk in foot-mounted design

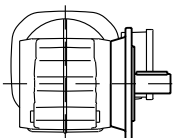
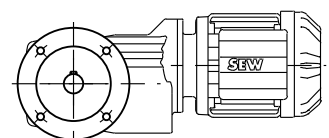

KF19 DR., KF29 DR..

Helical-bevel gearmotor in B5 flange-mounted design

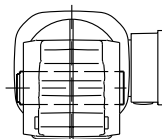
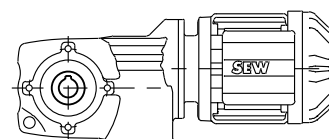

KA19 DR., KA29 DR..

Helical-bevel gearmotor with hollow shaft

20272545/EN – 11/2015

3 Overview of types and type designations

Gearmotor types

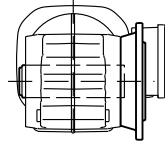
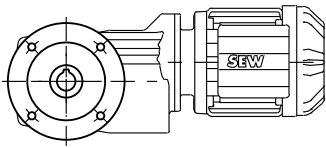

KAF19 DR.., KAF29 DR..

Helical-bevel gearmotor in B5 flange-mounted design with hollow shaft

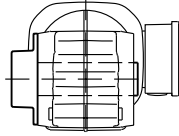
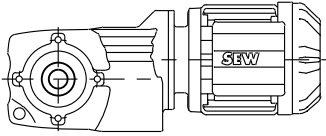

KH19 DR.., KH29 DR..

Helical-bevel gearmotor with hollow shaft and shrink disk

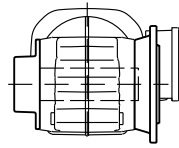
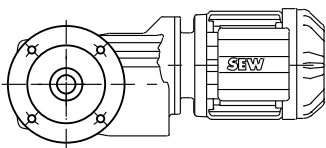

KHF19 DR.., KHF29 DR..

Helical-bevel gearmotor in B5 flange-mounted design with hollow shaft and shrink disk

3.6.4 Helical-bevel gearmotors, gear unit sizes K..39 and K..49

The following types of helical-bevel gearmotors with gear units of size K..39 and K..49 are available:

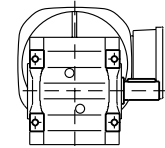
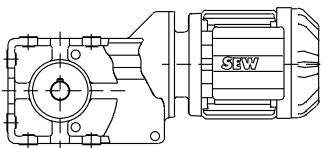

K39 DR.., K49 DR..

Helical-bevel gearmotor in foot-mounted design

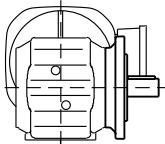
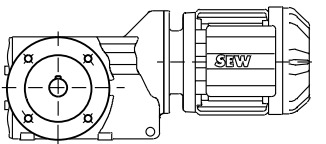

KF39 DR.., KF49 DR..

Helical-bevel gearmotor in B5 flange-mounted design

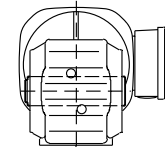
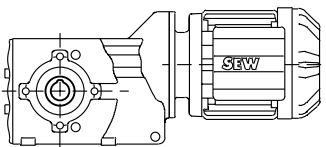

KA39 DR.., KA49 DR..

Helical-bevel gearmotor with hollow shaft

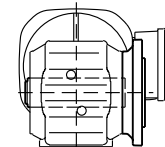
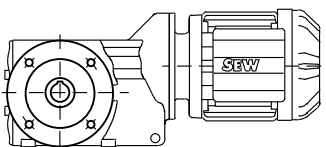

KAF39 DR.., KAF49 DR..

Helical-bevel gearmotor in B5 flange-mounted design with hollow shaft

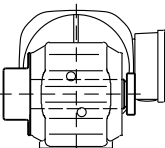
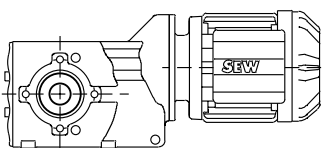

KT39 DR.., KT49 DR..

Helical-bevel gearmotor with hollow shaft and TorqLOC[®] hollow shaft mounting system

3.6.5 Helical-bevel gearmotors, gear unit sizes K..7

The following types of helical-bevel gearmotors with gear units of size K..7 are available:

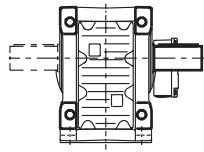
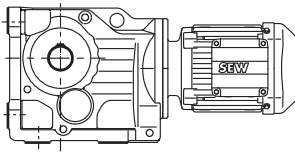

K..7 DR..

Helical-bevel gearmotor in foot-mounted design

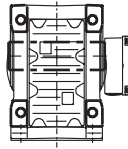
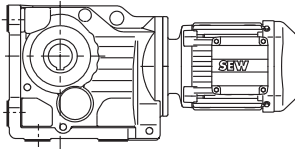

KA..7B DR..

Helical-bevel gearmotor in foot-mounted design with hollow shaft

KV..7B DR..

Helical-bevel gearmotor in foot-mounted design with splined hollow shaft to DIN 5480

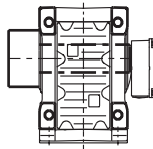
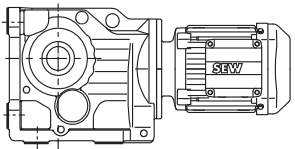

KH..7B DR..

Helical-bevel gearmotor in foot-mounted design with hollow shaft and shrink disk

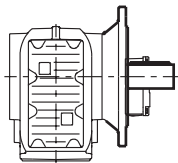
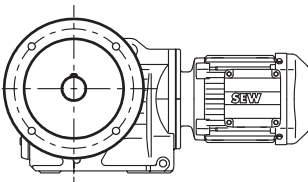

KF..7 DR..

Helical-bevel gearmotor in B5 flange-mounted design

KAF..7 DR..

Helical-bevel gearmotor in B5 flange-mounted design with hollow shaft

KVF..7 DR..

Helical-bevel gearmotor in B5 flange-mounted design with splined hollow shaft to DIN 5480

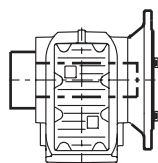
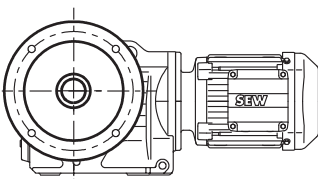
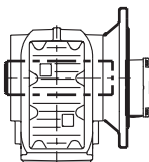
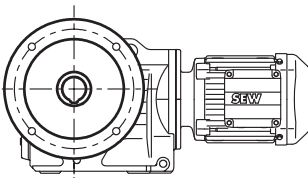

KHF..7 DR..

Helical-bevel gearmotor in B5 flange-mounted design with hollow shaft and shrink disk

KA..7 DR..

Helical-bevel gearmotor with hollow shaft

KV..7 DR..

Helical-bevel gearmotor with splined hollow shaft to DIN 5480

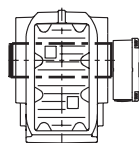
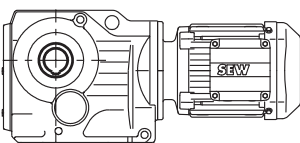

3 Overview of types and type designations

Gearmotor types

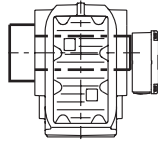
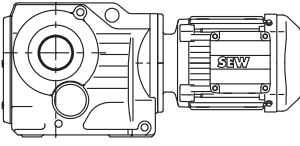

KH..7 DR..

Helical-bevel gearmotor with hollow shaft and shrink disk

KT..7 DR..

Helical-bevel gearmotor with hollow shaft and TorqLOC[®] hollow shaft mounting system

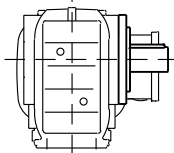
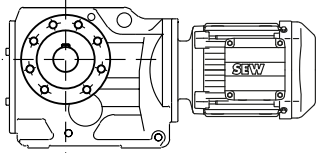

KZ..7 DR..

Helical-bevel gearmotor in B14 flange-mounted design

KAZ..7 DR..

Helical-bevel gearmotor in B14 flange-mounted design with hollow shaft

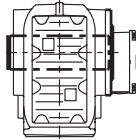
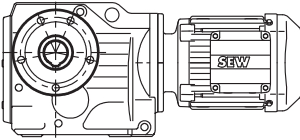

KVZ..7 DR..

Helical-bevel gearmotor in B14 flange-mounted design with splined hollow shaft to DIN 5480

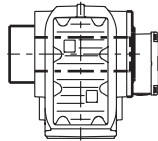
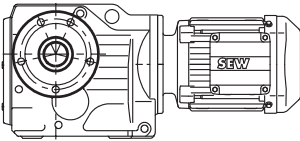

KHZ..7 DR..

Helical-bevel gearmotor in B14 flange-mounted design with hollow shaft and shrink disk

3.6.6 Helical-worm gearmotors

The following types of helical-worm gearmotors can be supplied:

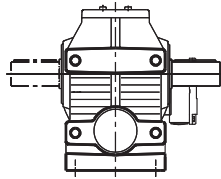
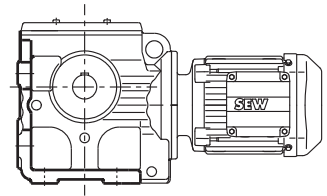

S..DR..

Helical-worm gearmotor in foot-mounted design

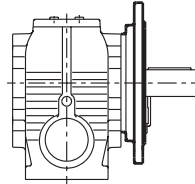
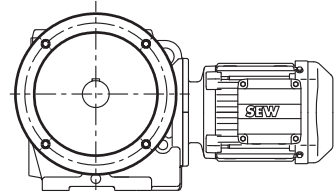

SF..DR..

Helical-worm gearmotor in B5 flange-mounted design

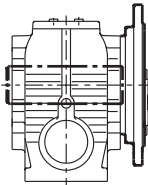
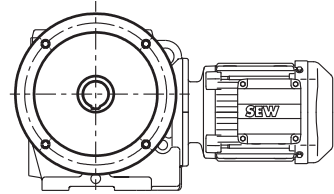

SAF..DR..

Helical-worm gearmotor in B5 flange-mounted design with hollow shaft

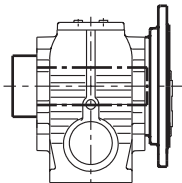
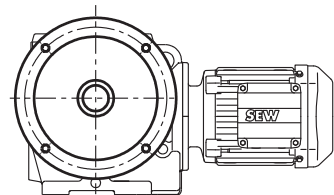

SHF..DR..

Helical-worm gearmotor in B5 flange-mounted design with hollow shaft and shrink disk

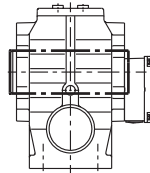
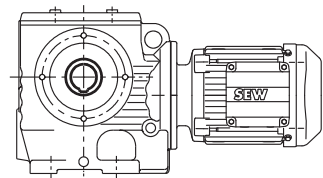

SA..DR..

Helical-worm gearmotor with hollow shaft

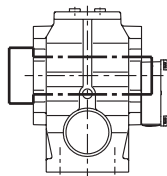
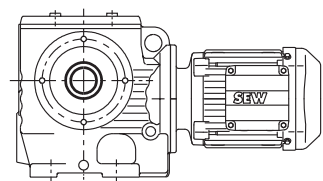

SH..DR..

Helical-worm gearmotor with hollow shaft and shrink disk

ST..DR..

Helical-worm gearmotor with hollow shaft and TorqLOC® hollow shaft mounting system

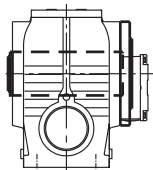
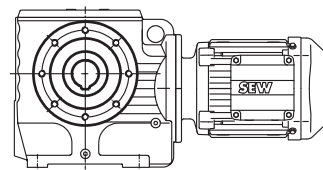

SAZ..DR..

B14 flange-mounted helical-worm gearmotor with hollow shaft

20272545/EN – 11/2015

3 Overview of types and type designations

Gearmotor types

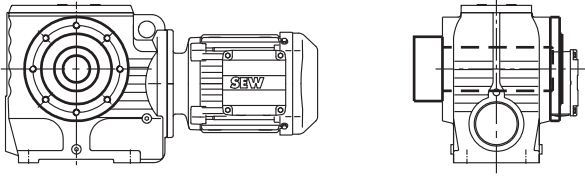

SHZ..DR..

Helical-worm gearmotor in B14 flange-mounted h design with hollow shaft and shrink disk

3.6.7 SPIROPLAN® gearmotors, gear unit sizes W..10, W..20, W..30

The following designs of SPIROPLAN® gearmotors with gear units in sizes W..10, W..20, and W..30 are available:

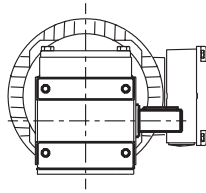
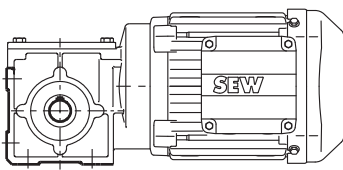

W10 DR.., W20 DR.., W30 DR..,

SPIROPLAN® gearmotor in foot-mounted design

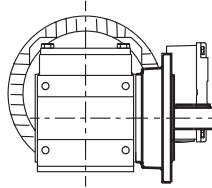
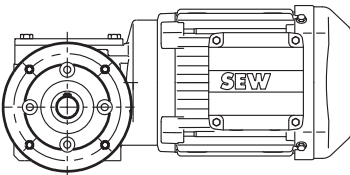

WF10 DR.., WF20 DR.., WF30 DR..

SPIROPLAN® gearmotor in B5 flange-mounted design

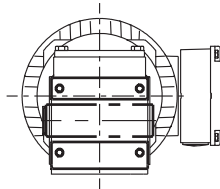
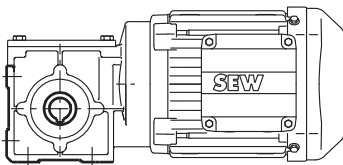

WA10 DR.., WA20 DR.., WA30 DR..

SPIROPLAN® gearmotor with hollow shaft

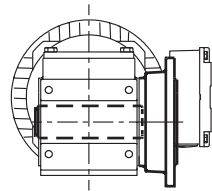
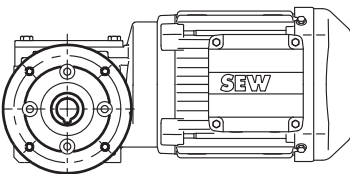

WAF10 DR.., WAF20 DR.., WAF30 DR..

SPIROPLAN® gearmotor in B5 flange-mounted design with hollow shaft

3.6.8 SPIROPLAN® gearmotors, gear unit sizes W..37 and W..47

The following designs of SPIROPLAN® gearmotors with gear units in sizes W..37 and W..47 are available:

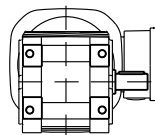
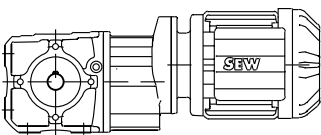

W37 DR.., W47 DR..

SPIROPLAN® gearmotor in foot-mounted design

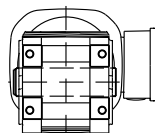
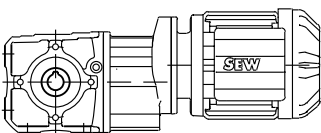

WA37B DR.., WA47B DR..

SPIROPLAN® gearmotor in foot-mounted design with hollow shaft

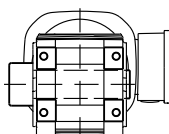
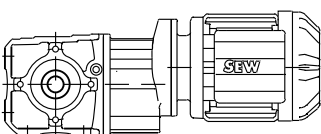

WH37B DR.., WH47B DR..

SPIROPLAN® gearmotor in foot-mounted design with hollow shaft and shrink disk

20272545/EN – 11/2015

3 Overview of types and type designations

Gearmotor types

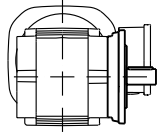
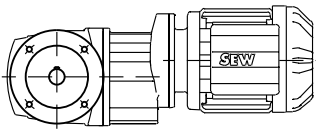

WF37 DR..., WF47 DR..

SPIROPLAN® gearmotor in B5 flange-mounted design

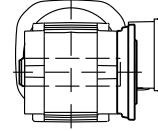
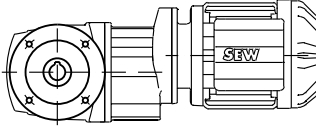

WAF37 DR..., WAF47 DR..

SPIROPLAN® gearmotor in B5 flange-mounted design with hollow shaft

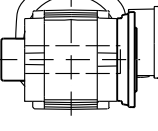
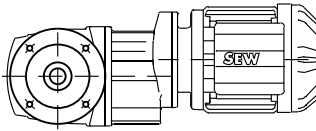

WHF37 DR..., WHF47 DR..

SPIROPLAN® gearmotor in B5 flange-mounted design with hollow shaft and shrink disk

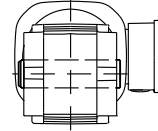
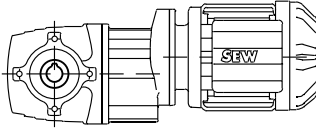

WA37 DR..., WA47 DR..

SPIROPLAN® gearmotor with hollow shaft

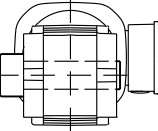
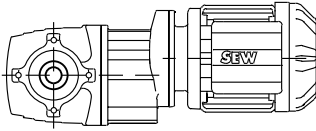

WH37 DR..., WH47 DR..

SPIROPLAN® gearmotor with hollow shaft and shrink disk

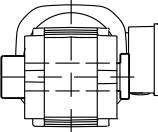
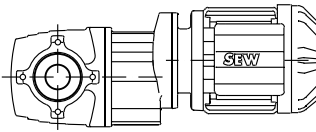

WT37 DR..., WT47 DR..

SPIROPLAN® gearmotor with hollow shaft and TorqLOC® hollow shaft mounting system

4 Project planning for drives

4.1 Additional publications

For more details on the subject of project planning for drives, visit the SEW-EURODRIVE website where you can order or download the following publications of the "Drive Engineering – Practical Implementation" series:

- Project Planning for Drives
- EMC in Drive Engineering – Basic Theoretical Principles and EMC-Compliant Installation in Practice
- Efficient Plant Automation with Mechatronic Drive Solutions
- SEW encoder systems
- Servo Technology
- Drive Engineering - Practical Implementation: Explosion-Proof Drives to EU Directive 94/9/EC

4.2 Drive and gear unit selection data

Certain data of the application have to be provided precisely define the components for your drive.

Designation	Meaning	Unit
n_{amin}	Minimum output speed	1/min
n_{amax}	Maximum output speed	1/min
P_a at n_{amin}	Output power at minimum output speed	kW
P_a at n_{amax}	Output power at maximum output speed	kW
M_a at n_{amin}	Output torque at minimum output speed	Nm
M_a at n_{amax}	Output torque at maximum output speed	Nm
F_A	Axial load (tension and compression) on the output shaft	N
J_{load}	Mass moment of inertia to be driven	10^{-4} kgm ²
R, F, K, S, W M1 - M6	Mounting position and required gear unit type; See chapter "Gear unit mounting positions" (→ 53) and "Project planning notes R, F, K, S, W gear units" (→ 41)	-
IP..	Required degree of protection	-
$\vartheta_{ambient}$	Ambient temperature	°C
H	Installation altitude	m above sea level
S.., ..% cdf	Duty type and cyclic duration factor cdf – the exact load cycle can be entered instead	-
Z	Starting frequency; alternatively, exact load cycle can be specified	1/h
f_{line}	Line frequency	Hz
V_{Mot} V_{brake}	Operating voltage of motor and brake	V
M_B	Required braking torque	Nm

Determining the motor data

To select the proper drive, you first need the data (mass, speed, setting range, etc.) of the machine to be driven.

These data help determine the required power, torque and speed. Refer to the "Drive Engineering – Practical Implementation, Project Planning" publication or the SEW Workbench project planning software for assistance.

Selecting the correct drive

The appropriate drive can be determined with the calculated power and speed and with other mechanical requirements taken into account.

4.3 Project planning procedure for DR.. gearmotors

4.3.1 Drive selection – non-controlled operation

The following flow diagram illustrates the project planning procedure for a non-controlled drive. The drive consists of a gearmotor operated on the grid.

Necessary information regarding the machine to be driven

- Technical data and ambient conditions
- Stopping accuracy
- Output speed
- Starting acceleration and deceleration
- Cyclic duration factor and starting frequency



Calculation of the relevant application data

- Static and dynamic power
- Speeds
- Torques, power ratings
- Travel diagram, if required
- Determine the necessary service factor f_B



Motor selection

- Torque/power/speed (number of poles)
- Acceleration torque/starting torque
- Switching frequency
- Determine energy efficiency class IE
- Mechanical brake (braking work, braking torque, brake service life)
- Motor equipment (brake, plug connector, thermal motor protection, etc.)



Gear unit selection

- Definition of gear unit type, gear unit size, gear unit ratio, and gear unit design
- Check the positioning accuracy
- Check the service factor f_B



Make sure that all requirements have been met.

4.4 Project planning information – R, F, K, S, W gear units

4.4.1 Efficiency of gear units

General information

The efficiency of gear units is mainly determined by the gearing and bearing friction. Keep in mind that the starting efficiency of a gear unit is always less than its efficiency at operating speed. This applies in particular to helical-worm and SPIROPLAN® right-angle gear units.

R, F, K gear units

Depending on the number of gear stages, the gearing efficiency of helical, parallel-shaft and helical-bevel gear units is up to 96% (3-stage), 97% (2-stage) and 98% (1-stage).

S and W gear units

The gearing in helical-worm and SPIROPLAN® gear units produces a high proportion of sliding friction. This is the reason why these gear units have higher gearing losses and lower efficiency than R, F or K gear units.

Other factors influencing the efficiency:

- Gear ratio of the helical-worm or SPIROPLAN® stage
- Input speed
- Gear unit temperature

Helical-worm gear units from SEW-EURODRIVE are helical gear/worm combinations that have a significantly higher efficiency than plain worm gear units, see chapter "Technical data S. SF. SA. SAF 37" (→ 404) and following.

The efficiency may reach $\eta < 0.5$ if the helical-worm gear stage has a very high gear ratio.

Self-locking

Retrodriving torque in helical-worm or SPIROPLAN® gear units produces an efficiency of $\eta' = 2 - 1/\eta$, which is significantly less favorable than the forward efficiency η . The helical-worm or SPIROPLAN® gear unit is self-locking if the forward efficiency is ≤ 0.5 . Some SPIROPLAN® gear units are also dynamically self-locking. Contact SEW-EURODRIVE if you want to make technical use of the braking effect of self-locking characteristics.

INFORMATION



Note that the self-locking effect of helical-worm and SPIROPLAN® gear units is not permitted as the sole safety function for hoists.

Run-in phase

The tooth flanks of new helical-worm and SPIROPLAN® gear units are not yet completely smooth. That fact makes for a greater friction angle and less efficiency than during later operation. This effect intensifies with increasing gear ratio.

During the run-in phase, the nominal efficiency of the gear unit is reduced by the relevant value from the following tables.

	Worm	
	i range	η reduction
1-start	approx. 50 – 280	approx. 12%
2-start	approx. 20 – 75	approx. 6%
3-start	approx. 20 – 90	approx. 3%
5-start	approx. 6 – 25	approx. 3%
6 start	approx. 7 – 25	approx. 2 %

SPIROPLAN® W10 to W30		SPIROPLAN® W37 and W47	
i range	η reduction	i range	η reduction
approx. 35 – 75	approx. 15%	-	-
approx. 20 – 35	approx. 10%	-	-
approx. 10 – 20	approx. 8%	approx. 30 – 70	approx. 8%
approx. 8	approx. 5%	approx. 10 – 30	approx. 5%
approx. 6	approx. 3%	approx. 3 – 10	approx. 3%

The run-in phase usually lasts 48 hours. The following conditions must be met for helical-worm and SPIROPLAN® gear units to achieve their nominal efficiency ratings:

- The gear unit has been completely run-in.
- The gear unit has reached nominal operating temperature.
- The recommended lubricant has been filled.
- The gear unit is operating in the nominal load range.

Churning losses

In certain gear unit mounting positions, see chapter "Gear unit mounting positions" (→ 53), the first gearing stage is completely immersed in the lubricant. When the circumferential velocity of the input gear stage is high, considerable churning losses occur in larger gear units that must be taken into account. Contact SEW-EURODRIVE in such a case.

To reduce churning losses to a minimum, use gear units in M1 mounting position.

4.5 Service factor

4.5.1 Determining the service factor

The effect of the driven machine on the gear unit is taken into account to a sufficient level of accuracy using the service factor f_B . The service factor is determined according to the daily operating time and the starting frequency Z . Three load classifications are taken into account depending on the mass acceleration factor. You can read the service factor applicable to your application from the following diagram. The determined service factor must be smaller than or equal to the service factor according to the selection tables (see chapter Structure of the selection tables).

Conditions for the service factor

$$M_a \times f_B \leq M_{amax}$$

M_a Output torque in Nm

f_B SEW service factor

M_{amax} Maximum output torque in Nm

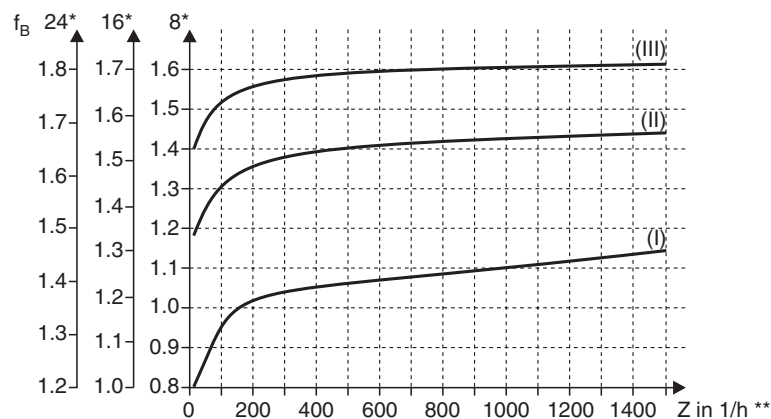

* Service factor in relation to the daily operating time in hours/day

** Starting frequency Z : The cycles include all starting and braking procedures as well as changeovers from low to high speed and vice versa.

I, II, III Load classification

Load classification

Three load classifications are distinguished:

- (I) Uniform, permitted mass acceleration factor ≤ 0.2
- (II) Non-uniform, permitted mass acceleration factor ≤ 3
- (III) Non-uniform, permitted mass acceleration factor ≤ 10

Mass acceleration factor

The mass acceleration factor is calculated as follows:

$$\text{Mass acceleration factor} = \frac{\text{All external mass moments of inertia}}{\text{Mass moment of inertia at motor end}}$$

"All external mass moments of inertia" are the mass moments of inertia of the driven machine and the gear unit, scaled down to the motor speed. The calculation for scaling down to motor speed is performed using the following formula:

Scaling down the mass moment of inertia on the motor shaft

$$J_X = J \times \left(\frac{n}{n_M} \right)^2$$

- J_X Reduced mass moment of inertia on the motor shaft
- J Mass moment of inertia with reference to the output speed of the gear unit
- n Output speed of the gear unit
- n_M Motor speed

"Mass moment of inertia at the motor end" is the mass moment of inertia of the motor and, if installed, the brake and the flywheel fan (Z fan).

Service factors $f_B > 1.8$ may occur with large mass acceleration factors (> 10), high levels of backlash in the transmission elements or large overhung loads. Contact SEW-EURODRIVE in such a case.

4.5.2 Service factor SEW f_B

The method for determining the maximum permitted continuous torque M_{amax} and using this value to derive the service factor $f_B = M_{amax}/M_a$ is not defined in a standard and varies greatly from manufacturer to manufacturer. Even at a SEW service factor $f_B = 1$, the gear units afford an extremely high level of safety and reliability in the fatigue strength range (exception: wearing of the worm gear in helical-worm gear units). The service factor may differ from specifications of other gear unit manufacturers. If in doubt, contact SEW-EURODRIVE.

Example

Mass acceleration factor 2.5 (load classification II), operating time 14 hours/day (read off at 16 h/d) and 300 cycles/hour produce a service factor $f_B = 1.5$, as shown in the figure on the previous page. According to the selection tables, the selected gearmotor must have an SEW- f_B value of 1.5 or greater.

4.5.3 Helical-worm gear unit

In the case of helical-worm gear units, two further service factors have to be taken into account in addition to the service factor f_B shown in the above diagram. They are:

- f_{B1} = Service factor from ambient temperature
- f_{B2} = Service factor from cyclic duration factor

The additional service factors f_{B1} and f_{B2} can be determined by referring to the diagram below. For f_{B1} , the load classification is taken into account in the same way as for f_B . The following diagram shows the additional service factors f_{B1} and f_{B2} :

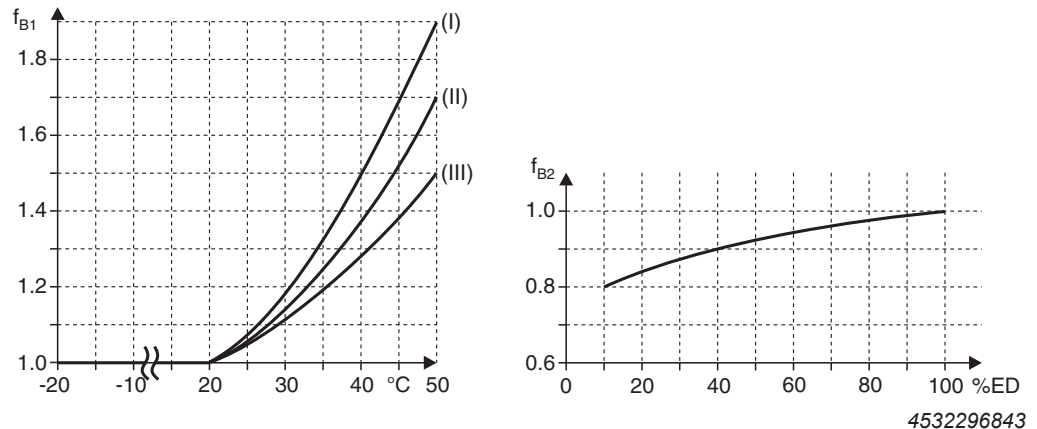

Cyclic duration factor

$$CDF = \frac{\text{Time under load in min / h}}{60} \times 100$$

CDF Cyclic duration factor in %

Contact SEW-EURODRIVE in the case of temperatures below -20°C (→ diagram f_{B1}).

The total service factor for helical-worm gear units is calculated as follows:

Total service factor $f_{Btot} = f_B \times f_{B1} \times f_{B2}$

f_{Btot} Total service factor

f_B SEW service factor

f_{B1} Service factor from ambient temperature

f_{B2} Service factor from cyclic duration factor

Example

The gearmotor with the service factor $f_B = 1.51$ in the previous example is to be a helical-worm gearmotor.

Ambient temperature $\vartheta = 40^\circ\text{C} \rightarrow f_{B1} = 1.38$ (read off at load classification II)

Time under load = 40 min/h \rightarrow CDF = 66.67% $\rightarrow f_{B2} = 0.95$

The total service factor is $f_{Btot} = 1.51 \times 1.38 \times 0.95 = 1.98$

According to the selection tables, the selected helical-worm gearmotor must have an SEW f_B service factor of 1.98 or greater.

4.6 Overhung and axial loads

4.6.1 Determining the overhung load

When determining the resulting overhung load, the type of transmission element mounted on the shaft end must be considered. The following transmission element factors f_z have to be considered for various transmission elements.

Transmission element	Transmission element factor f_z	Comments
Gears	1.15	< 17 teeth
Sprockets	1.40	< 13 teeth
Sprockets	1.25	< 20 teeth
Narrow V-belt pulleys	1.75	Influence of the pre-tensioning force
Flat belt pulleys	2.50	Influence of the pre-tensioning force
Toothed belt pulleys	1.50	Influence of the pre-tensioning force
Gear rack pinion, pre-tensioned	2.00	Influence of the pre-tensioning force

The overhung force load exerted on the motor or gear unit shaft is then calculated as follows:

$$F_R = \frac{M_d \times 2000}{d_0} \times f_z$$

F_R Overhung load in N

M_d Torque in Nm

d_0 Mean diameter of the installed transmission element in mm

f_z Transmission element factor

4.6.2 Permitted overhung load

The basis for determining the permitted overhung loads is the rolling bearing calculation of the rated bearing service life L_{10h} (according to ISO 281).

For special operating conditions, the permitted overhung loads can be determined on the basis of the modified service life L_{na} on request.

The permitted overhung loads F_{Ra} for the output shafts of foot-mounted gear units with a solid shaft are listed in the selection tables for gearmotors. For other designs, please contact SEW-EURODRIVE.

INFORMATION



The values refer to force applied to the center of the shaft end (in right-angle gear units as viewed onto the A-side output). The values for the force application angle α and direction of rotation are based on the most unfavorable conditions.

- Only 50% of the F_{Ra} value specified in the selection tables is permitted in mounting position M1 with wall attachment on the front face for K and S gear units.
- Helical-bevel gearmotors K167 and K187 in mounting positions M1 to M4: A maximum of 50% of the overhung load F_{Ra} specified in the selection tables is permitted in the case of gear unit mounting other than as shown in the mounting position sheets.
- In case of helical-bevel gear units K167 and K187 in mounting position M5 and M6 only the mounting surface at the defined output end without restriction of F_{Ra} is possible. For other mounting designs, please contact SEW-EURODRIVE.
- Helical gearmotors in foot-mounted and flange-mounted design (R..F): A maximum of 50% of the overhung load F_{Ra} specified in the selection tables is permitted in the case of torque transmission via the flange mounting.

4.6.3 Higher permitted overhung loads

Exactly considering the force application angle α and the direction of rotation makes it possible to achieve a higher overhung load than listed in the selection tables.

Furthermore, higher output shaft loads are permitted if heavy duty bearings are installed, especially with R, F and K gear units.

Contact SEW-EURODRIVE in such cases.

4.6.4 Definition of the force application

Force application is defined according to the following figure:

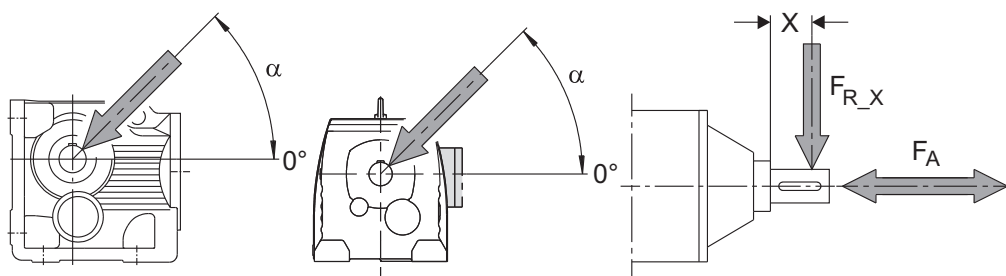

9007203549116427

F_{R_X} Permitted overhung load at point x in N

F_A Permitted axial load in N

α Force application angle

4.6.5 Permitted axial forces

If there is no overhung load, then an axial load F_A (tension or compression) amounting to 50 % of the overhung load given in the selection tables is permitted. This condition applies to the following gearmotors:

- Helical gearmotors except for R..137... to R..167...

4 Project planning for drives

Overhung and axial loads

- Parallel shaft and helical-bevel gearmotors with solid shaft except for F97...
- Helical-worm gearmotors with solid shaft

INFORMATION



Contact SEW-EURODRIVE for all other types of gear units and in the event of significantly greater axial forces or combinations of overhung load and axial force.

4.6.6 On the output side: Overhung load conversion for off-center force application

The permitted overhung loads must be calculated according the selection tables using the following formula in the event that force is not applied at the center of the shaft end. The smaller of the two values F_{R_XL} (according to bearing service life) and F_{R_RW} (according to shaft strength) is the permitted value for the overhung load at point X. Note that the calculations apply to M_{a_max} .

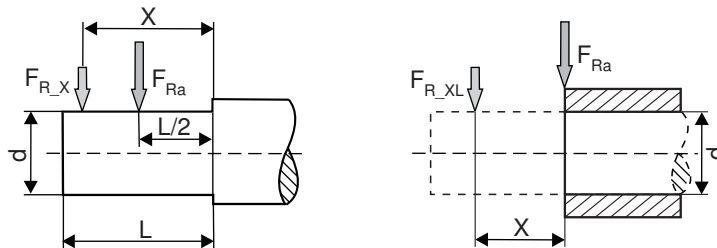

Overhung load F_{R_x} for off-center force application

41100683

F_{R_XL} based on bearing service life

$$F_{R_XL} = F_{Ra} \times \frac{a}{b + X}$$

F_{R_XW} based on shaft strength

$$F_{R_XW} = \frac{c}{f + X}$$

- F_{Ra} Permitted overhung load ($X = L/2$) based on M_{a_max} in N for foot-mounted gear units according to selection tables
- X Distance from the shaft shoulder to the force application point in mm
- a, b, f Gear unit constants for overhung load conversion in mm
- c Gear unit constant for overhung load conversion in Nmm

Gear unit constants for overhung load conversion

Gear unit type	a mm	b mm	c Nmm	f mm	d mm	l mm
RX57	43.5	23.5	1.51×10^5	34.2	20	40
RX67	52.5	27.5	2.42×10^5	39.7	25	50
RX77	60.5	30.5	1.95×10^5	0	30	60
RX87	73.5	33.5	7.69×10^5	48.9	40	80
RX97	86.5	36.5	1.43×10^6	53.9	50	100
RX107	102.5	42.5	2.47×10^6	62.3	60	120
R07	72.0	52.0	4.67×10^4	11	20	40
R17	88.5	68.5	6.527×10^4	17	20	40
R27	106.5	81.5	1.56×10^5	11.8	25	50
R37	118	93	1.24×10^5	0	25	50
R47	137	107	2.44×10^5	15	30	60
R57	147.5	112.5	3.77×10^5	18	35	70
R67	168.5	133.5	2.65×10^5	0	35	70
R77	173.7	133.7	3.97×10^5	0	40	80
R87	216.7	166.7	8.47×10^5	0	50	100
R97	255.5	195.5	1.06×10^6	0	60	120
R107	285.5	215.5	2.06×10^6	0	70	140
R137	343.5	258.5	4.58×10^6	0	90	170
R147	402	297	8.65×10^6	33	110	210
R167	450	345	1.26×10^7	0	120	210
F27	109.5	84.5	1.13×10^5	0	25	50
F37	123.5	98.5	1.07×10^5	0	25	50
F47	153.5	123.5	1.40×10^5	0	30	60
F57	170.7	135.7	2.70×10^5	0	35	70
F67	181.3	141.3	4.12×10^5	0	40	80
F77	215.8	165.8	7.87×10^5	0	50	100
F87	263	203	1.06×10^6	0	60	120
F97	350	280	2.09×10^6	0	70	140
F107	373.5	288.5	4.23×10^6	0	90	170
F127	442.5	337.5	9.45×10^6	0	110	210
F157	512	407	1.05×10^7	0	120	210
K19	103.7	83.7	8.66×10^4	0	20	40
K29	124.5	99.5	1.26×10^5	0	25	50
K37	123.5	98.5	1.30×10^5	0	25	50
K39	155.5	125.5	2.25×10^5	0	30	60
K47	153.5	123.5	1.40×10^5	0	30	60
K49	183.5	148.5	2.63×10^5	0	35	70
K57	169.7	134.7	2.70×10^5	0	35	70
K67	181.3	141.3	4.12×10^5	0	40	80
K77	215.8	165.8	7.69×10^5	0	50	100
K87	252	192	1.64×10^6	0	60	120
K97	319	249	2.80×10^6	0	70	140
K107	373.5	288.5	5.53×10^6	0	90	170
K127	443.5	338.5	8.31×10^6	0	110	210
K157	509	404	1.18×10^7	0	120	210
K167	621.5	496.5	1.88×10^7	0	160	250
K187	720.5	560.5	3.04×10^7	0	190	320
S37	118.5	98.5	6.0×10^4	0	20	40
S47	130	105	1.33×10^5	0	25	50
S57	150	120	2.14×10^5	0	30	60
S67	184	149	3.04×10^5	0	35	70
S77	224	179	5.26×10^5	0	45	90
S87	281.5	221.5	1.68×10^6	0	60	120
S97	326.3	256.3	2.54×10^6	0	70	140
W10	84.8	64.8	3.6×10^4	0	16	40
W20	98.5	78.5	4.4×10^4	0	20	40
W30	109.5	89.5	6.0×10^4	0	20	40
W37	121.1	101.1	6.95×10^4	0	20	40
W47	145.5	115.5	4.26×10^5	35.6	30	60

Values for types not listed are available on request.

4 Project planning for drives

Project planning for RM gear units

4.7 Project planning for RM gear units

4.7.1 Project planning procedure

You must take account of the higher overhung and axial loads when planning projects with RM helical gearmotors with an extended bearing hub. Observe the following project planning procedure:

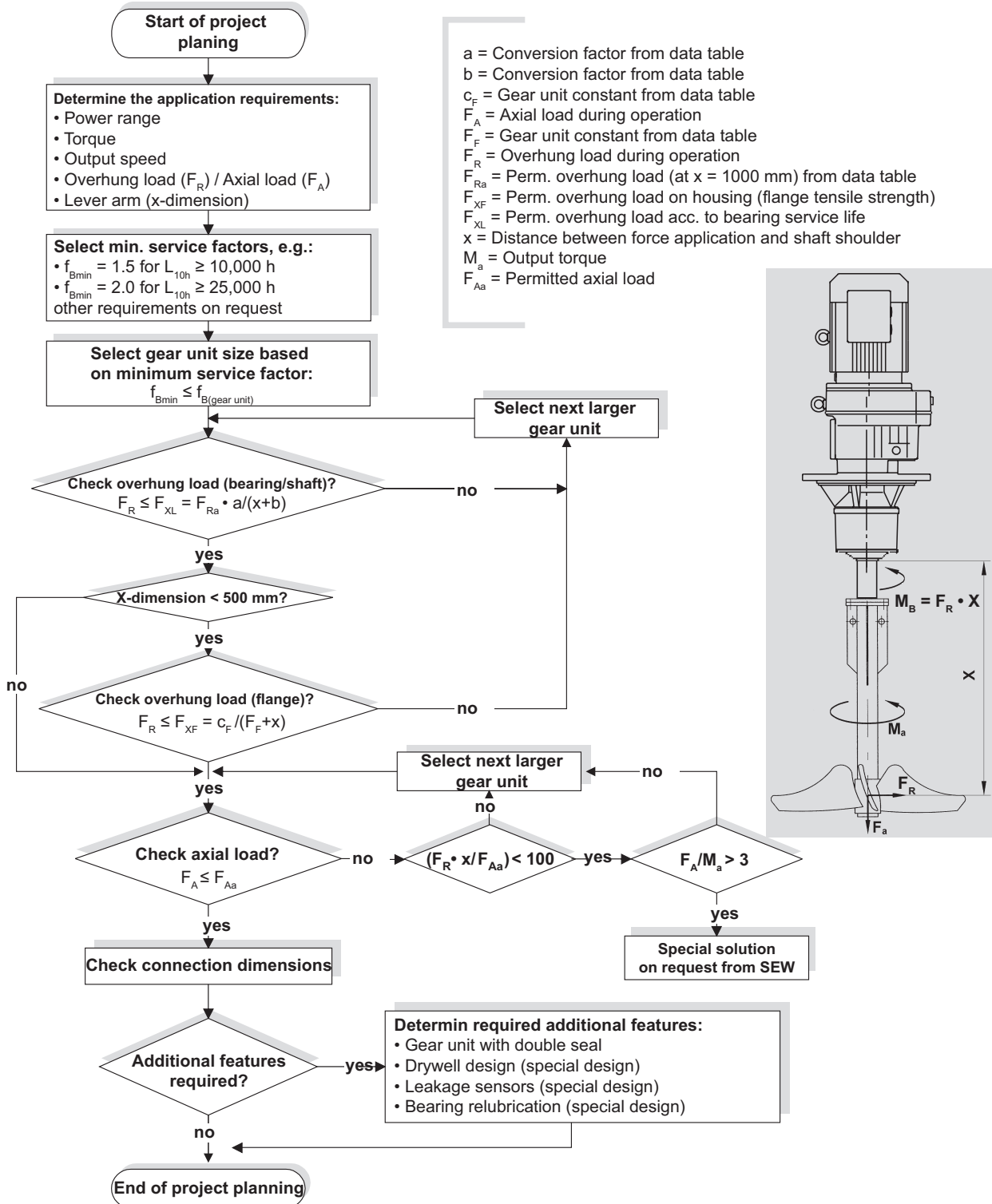

18014407208033419

20272545/EN – 11/2015

4.7.2 Permitted overhung loads and axial forces

The following table shows the permitted overhung loads F_{Ra} and axial loads F_{Aa} for various service factors f_B and nominal bearing service life L_{10h} .

$f_{Bmin} = 1.5$; $L_{10h} = 10\ 000\ h$

		n_a in 1/min							
		< 16	16-25	26-40	41-60	61-100	101-160	161-250	251-400
RM57	F_{Ra} in N	400	400	400	400	400	405	410	415
	F_{Aa} in N	18800	15000	11500	9700	7100	5650	4450	3800
RM67	F_{Ra} in N	575	575	575	580	575	585	590	600
	F_{Aa} in N	19000	18900	15300	11900	9210	7470	5870	5050
RM77	F_{Ra} in N	1200	1200	1200	1200	1200	1210	1210	1220
	F_{Aa} in N	22000	22000	19400	15100	11400	9220	7200	6710
RM87	F_{Ra} in N	1970	1970	1970	1970	1980	1990	2000	2010
	F_{Aa} in N	30000	30000	23600	18000	14300	11000	8940	8030
RM97	F_{Ra} in N	2980	2980	2980	2990	3010	3050	3060	3080
	F_{Aa} in N	40000	36100	27300	20300	15900	12600	9640	7810
RM107	F_{Ra} in N	4230	4230	4230	4230	4230	4230	3580	3830
	F_{Aa} in N	48000	41000	30300	23000	18000	13100	9550	9030
RM137	F_{Ra} in N	8710	8710	8710	8710	7220	5060	3980	6750
	F_{Aa} in N	70000	70000	70000	57600	46900	44000	35600	32400
RM147	F_{Ra} in N	11100	11100	11100	11100	11100	10600	8640	10800
	F_{Aa} in N	70000	70000	69700	58400	45600	38000	32800	30800
RM167	F_{Ra} in N	14600	14600	14600	14600	14600	14700	–	–
	F_{Aa} in N	70000	70000	70000	60300	45300	36900	–	–

$f_{Bmin} = 2.0$; $L_{10h} = 25\ 000\ h$

		n_a in 1/min							
		< 16	16-25	26-40	41-60	61-100	101-160	161-250	251-400
RM57	F_{Ra} in N	410	410	410	410	410	415	415	420
	F_{Aa} in N	12100	9600	7350	6050	4300	3350	2600	2200
RM67	F_{Ra} in N	590	590	590	595	590	595	600	605
	F_{Aa} in N	15800	12000	9580	7330	5580	4460	3460	2930
RM77	F_{Ra} in N	1210	1210	1210	1210	1210	1220	1220	1220
	F_{Aa} in N	20000	15400	11900	9070	6670	5280	4010	3700
RM87	F_{Ra} in N	2000	2000	2000	2000	2000	1720	1690	1710
	F_{Aa} in N	24600	19200	14300	10600	8190	6100	5490	4860
RM97	F_{Ra} in N	3040	3040	3040	3050	3070	3080	2540	2430
	F_{Aa} in N	28400	22000	16200	11600	8850	6840	5830	4760
RM107	F_{Ra} in N	4330	4330	4330	4330	4330	3350	2810	2990
	F_{Aa} in N	32300	24800	17800	13000	9780	8170	5950	5620
RM137	F_{Ra} in N	8850	8850	8850	8830	5660	4020	3200	5240
	F_{Aa} in N	70000	59900	48000	37900	33800	31700	25600	23300
RM147	F_{Ra} in N	11400	11400	11400	11400	11400	8320	6850	8440
	F_{Aa} in N	70000	60600	45900	39900	33500	27900	24100	22600
RM167	F_{Ra} in N	15100	15100	15100	15100	15100	13100	–	–
	F_{Aa} in N	70000	63500	51600	37800	26800	23600	–	–

4.7.3 Conversion factors and gear unit constants

The following conversion factors and gear unit constants apply to calculating the permitted overhung load F_{xL} at point $x \neq 1000$ mm for RM gearmotors:

Gear unit type	a	b	$c_F (f_B = 1.5)$	$c_F (f_B = 2.0)$	F_F
RM57	1047	47	1220600	1260400	277
RM67	1047	47	2047600	2100000	297.5
RM77	1050	50	2512800	2574700	340.5
RM87	1056.5	56.5	4917800	5029000	414
RM97	1061	61	10911600	11124100	481
RM107	1069	69	15367000	15652000	554.5
RM137	1088	88	25291700	25993600	650
RM147	1091	91	30038700	31173900	756
RM167	1089.5	89.5	42096100	43654300	869

4.7.4 Additional weight of RM gear units

Type	Additional weight compared to RF with reference to the smallest RF flange Δm in kg
RM57	12.0
RM67	15.8
RM77	25.0
RM87	29.7
RM97	51.3
RM107	88.0
RM137	111.1
RM147	167.4
RM167	195.4

5 Gear unit mounting positions and order information

5.1 General mounting position information – R, F, K, S, W gear units

The following illustration shows the SEW-EURODRIVE mounting positions M1 – M6 of the gear units:

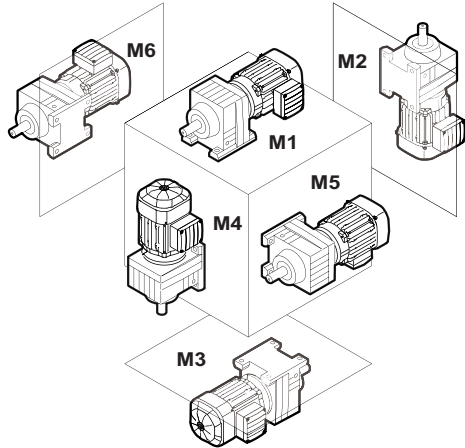

R..

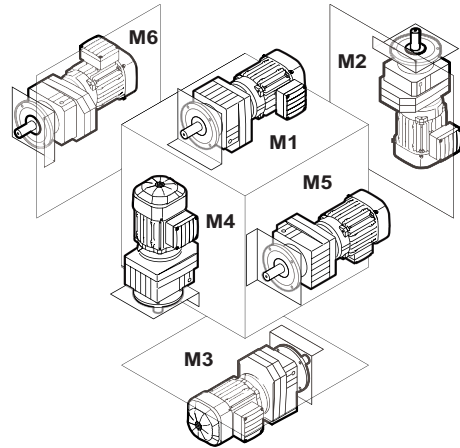

F..

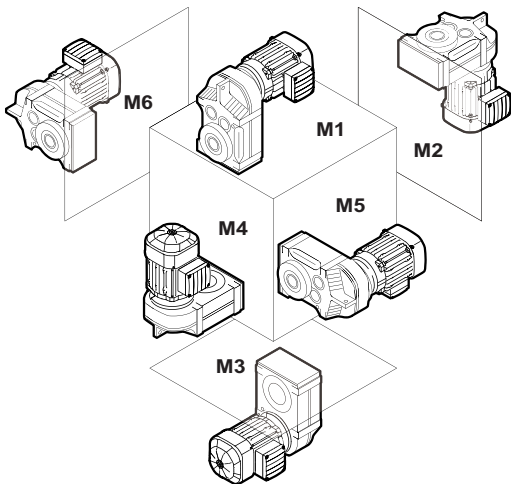

**K..
S..
W..**

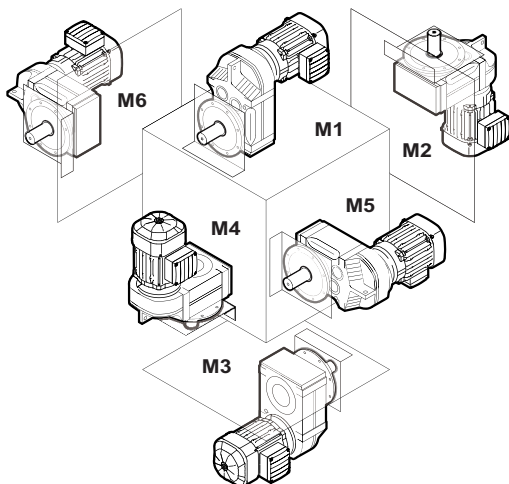

15649312267

5.2 Order information

INFORMATION



The following order information is required for R, F, K, S, and W gear units or gearmotors in addition to the mounting position to exactly determine the drive design.

This information is also required for gearmotors that do not depend on a particular mounting position.

5.2.1 Order information for all gear units and gearmotors

Observe the following notes for all gear units and gearmotors from SEW-EURODRIVE.

Output direction of rotation with backstop

The purpose of a backstop is to prevent unwanted directions of rotation. During operation, the backstop permits rotation only in the specified direction. If the drive has an RS backstop, you have to indicate the direction of rotation of the output for the drive.

The direction of rotation is specified as viewed onto the output shaft (LSS):

- CW rotation
- CCW rotation

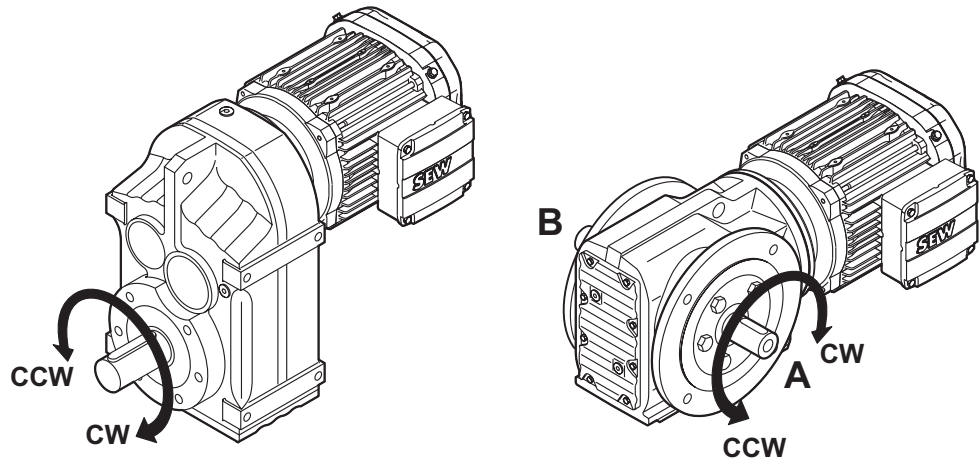

4579708555

In right-angle gear units, you also have to indicate whether the direction of rotation is given looking onto the A or B-side.

The permitted direction of rotation is indicated by a direction arrow on the housing:



15985405835

A replacement label is enclosed for the customer.

Position of the output shaft and the output flange

In right-angle gear units, you also have to indicate the position of the output shaft and the output flange:

- A or B or AB

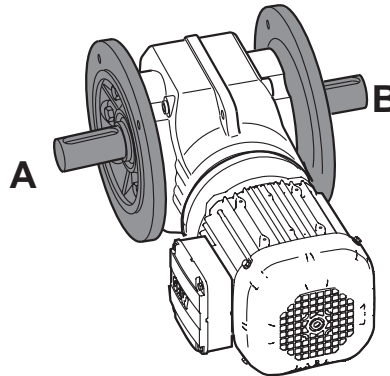

4579723275

Position of the output end in right-angle gear units

In shaft mounted right-angle gear units with a shrink disk, you also have to indicate whether the A or B-side is the output end. In the figure below, the A-side is the output end. The shrink disk is located opposite the output end.

In shaft mounted right-angle gear units, the designation "output end" is equivalent to the designation "shaft position" used for right-angle gear units with solid shaft.

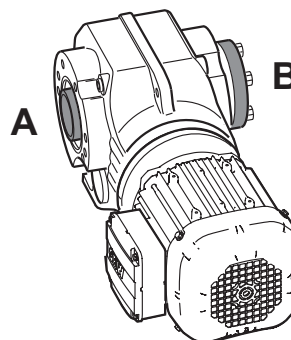

4579730955

INFORMATION



For the permitted mounting surfaces (= hatched area), refer to the mounting position sheets (see chapter "Mounting position sheets" (→ 63)).

5 Gear unit mounting positions and order information

Order information

5.2.2 Position of motor terminal box and cable entry

The standard EN 60034 specifies the following designations for motor terminal box positions:

- As viewed onto the output shaft = A-side.
- Designation as R (right), B (bottom), L (left) and T (top).

This new designation applies to motors without a gear unit in mounting position B3 (= M1).

Deviating from this standard, in case of gearmotors the position of the motor terminal box is specified with 0°, 90°, 180° or 270° as viewed onto the fan guard = B-side.

The following figure shows both designations. Where the mounting position of the motor changes, R, B, L and T are rotated accordingly.

The cable entry position is specified with x, 1, 2, 3.

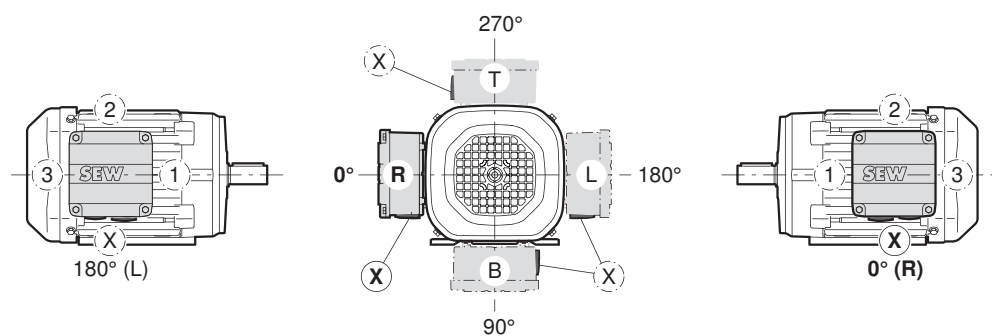

3975310859

INFORMATION



Unless indicated otherwise in your order, you will receive the terminal box type 270° with "x" cable entry.

5.2.3 Sample orders

Type (examples)	Mounting position	Shaft position	Flange position	Terminal box position	Cable entry position	Output direction of rotation
K47DRK71M4/RS	M2	A	-	0°	"X"	Clockwise
SF77DRS90L4	M6	AB	AB	90°	"3"	-
KA97DRE132M4	M4	B	-	270°	"2"	-
KH107DRN160M4	M1	A	-	180°	"3"	-
KAF67AM90	M3	A	B	-	-	-
K47DRE90MJ4	M2	A	-	0°	"X"	Clockwise

5.2.4 Position motor terminal box and foot for gearmotors with motor option /FM

With gearmotors, the motor is designed as flange-mounted motor for mounting to gear units. It is also possible to provide the motor with feet that can be used for customer components. The load values of the feet are available from SEW-EURODRIVE on request. The position of the foot must be specified in the order.

The following figure shows the possible positions of the terminal box and the feet for gearmotors with motor option /FM.

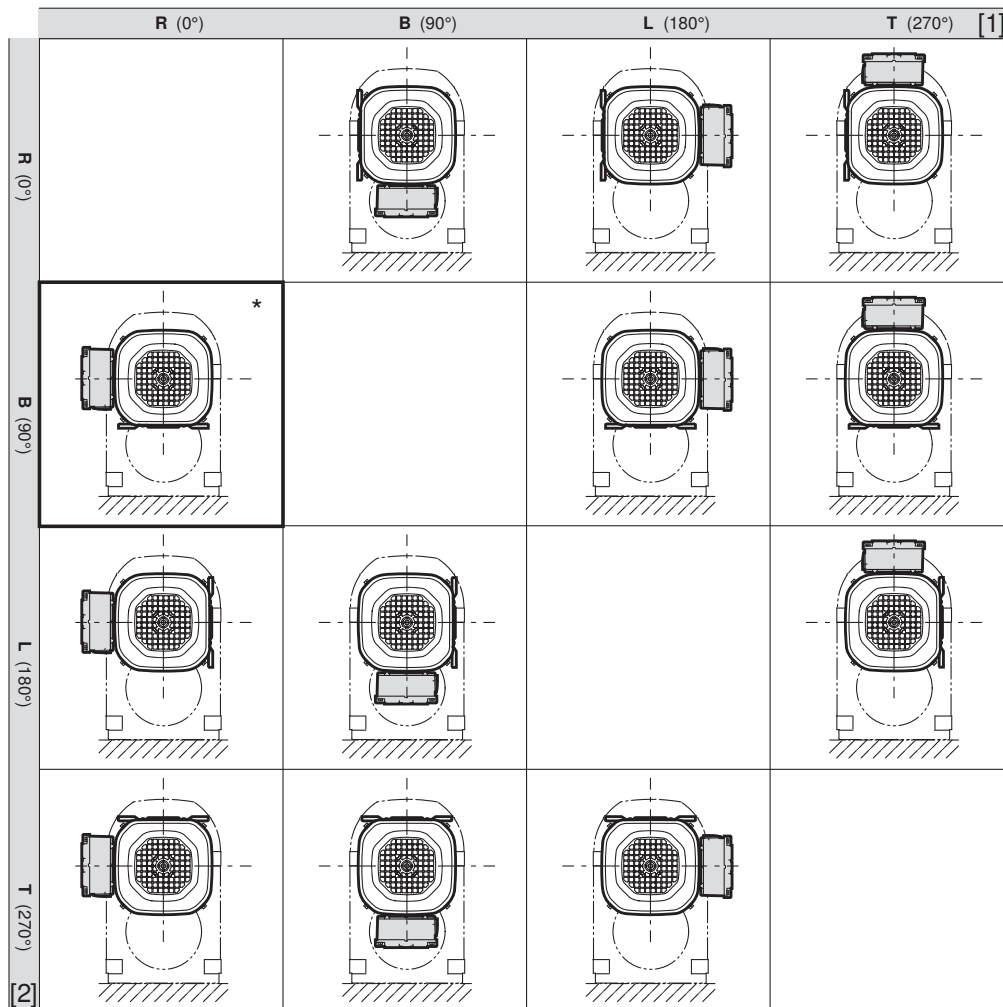

13588943243

[1] Terminal box positions

[2] Foot positions

- *) If not specified otherwise in the order, the gearmotor is delivered with foot position B (90°) and terminal box position R (0°).

INFORMATION



The foot on the motor is not suited to attach a complete gearmotor.

Example: Gearmotor with motor option /FM:

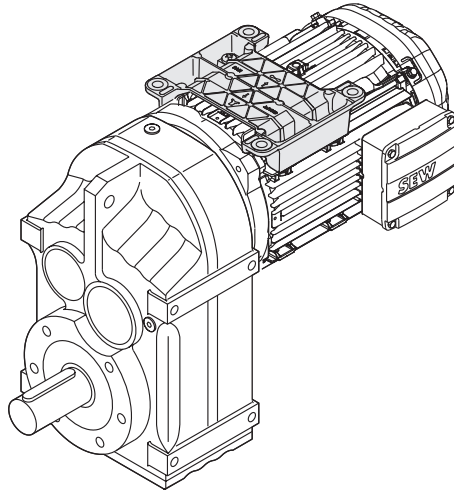

13678896779

Order information on mounting position of the complete drive, foot positions, terminal box and cable entry:

Mounting position complete drive:	M1
Terminal box position:	R (0°)
Cable entry:	X
Foot position:	T (270°)

5.2.5 Change of mounting position

Make sure to read the following information when you operate the gearmotor in a mounting position other than the one indicated in the order:

- Adjust the lubricant fill quantity to the changed mounting position.
- Adjust the position of the breather valve.
- When changing the mounting position to M4: Contact SEW-EURODRIVE. Depending on the drives operating mode, an oil expansion tank might be necessary (see chapter "Oil expansion tank" (→ 20)).
- For helical-bevel gearmotors: Contact SEW-EURODRIVE if you want to change to mounting position M5 or M6, independent of the initial mounting position.
- For helical-worm gearmotors: Contact the SEW-EURODRIVE when changing to mounting position M2 or M3.

5.3 Key to the mounting position sheets

INFORMATION



The positions of the breather valve, oil level plug, and oil drain plug specified in the mounting position sheets are binding and comply with the assembly specifications.

5



INFORMATION



SPIROPLAN® gearmotors are not dependent on the mounting position, except for W..37 and W..47 in mounting position M4. However, mounting positions M1 to M6 are also shown for SPIROPLAN® gearmotors to assist you in working with this documentation.

5.3.1 Symbols used

The following table shows the symbols used in the mounting position sheets and what they mean:

Icon	Meaning
	Breather valve
	Oil level plug ¹⁾
	Oil drain plug

1) Does not apply to the 1st gear unit (large gear unit) of compound gear units.

5.3.2 Churning losses

* (→  X)

Some gearmotors are marked with a * in the mounting position sheets (see chapter "Mounting position sheets" (→  63)). Churning losses may occur at gearmotors in those mounting positions. Contact SEW-EURODRIVE in case of the following combinations:

Mounting position	Gear unit type	Gear unit size	Input speed [min ⁻¹]
M2, M4	R	97 – 107	> 2500
		> 107	>1500
M2, M3, M4, M5, M6	F	97 – 107	> 2500
		> 107	>1500
	K	77 – 107	> 2500
		> 107	>1500
	S	77 – 97	> 2500

5.3.3 Displayed shaft

Observe the following information regarding the display of shafts on the mounting position sheets:

INFORMATION

For gear units with solid shaft: The displayed shaft is always on the A-side.

For shaft mounted gear units: The shaft with dashed lines represents the customer shaft. The output end (= shaft position) is always shown on the A-side end.

5.3.4 Position of breather valve/oil drain plug in motor flange

As shown in the mounting position sheets in chapter "Mounting position sheets" (→ 63), the position of the breather valve and oil drain plug depend on the gearmotor mounting position.

The following table shows the position of the breather valve and the oil drain plug depending on the mounting position:

Mounting position	Breather valve position	Oil drain plug position
M1, M3, M5, M6	In the gear unit housing	In the gear unit housing
M4	In the motor flange	In the gear unit housing
M2	In the gear unit housing	In the motor flange

If the breather valve (M4 mounting position) or the oil drain plug (M2 mounting position) is positioned in the motor flange, the position depends on the terminal box position.

INFORMATION



The positions of the breather valve/oil drain plug in the mounting position sheets in chapter "Mounting position sheets" (→ 63) and the following chapters always refers to the standard terminal box position 0°. Note that the position of the breather valve / oil drain plug is changed depending on the possible terminal box positions (90°, 180°, 270°).

The following illustration shows the exact position of the breather valve/oil drain plug in the motor flange.

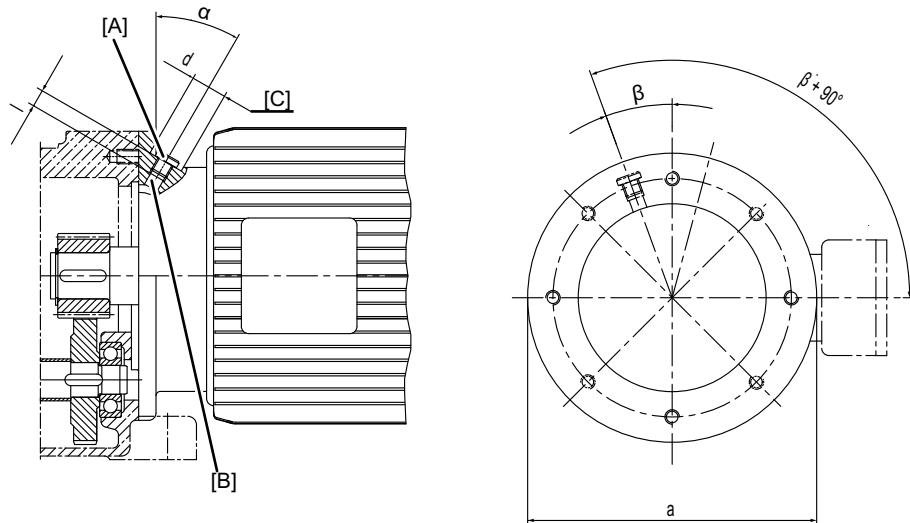

13066345867

- | | |
|--|---|
| <p>[A] Position of breather valve / oil drain plug</p> <p>[B] Continuous core drilling</p> <p>[C] Counterbored bore</p> <p>[α] Drill angle</p> | <p>[d] Diameter of the countersinking</p> <p>[l] Thread length</p> <p>[a] Flange diameter</p> <p>[β] Position angle</p> |
|--|---|

5 Gear unit mounting positions and order information

Key to the mounting position sheets

Dimension table

The following table contains the dimensions regarding the position of the breather valve and the oil drain plug depending on the motor size.

DR.. motor type	a in mm	α in °	β in °	Thread designation	$\varnothing d$ in mm	l in mm
ER63	120	30	45	M10x1	15	10
	160		22.5			
	200			M12x1.5	18	12
DR..71	120	0	45	M10x1	15	10
	160	30	22.5			
	200			M12x1.5	18	12
	250					
	300	90		M22x1.5	28	14
DR..80	120	30		22.5	M10x1	15
	160					
	200		M12x1.5		18	12
	250					
	300	90	M22x1.5		28	14
DR..90	120	30	22.5	M10x1	15	10
	160					11
	200			M12x1.5	18	14
	250					12
	300			M22x1.5	28	12

20272545/EN – 11/2015

5.4 Mounting position sheets

5.4.1 Mounting positions of helical gearmotors

RX57-RX107

04 043 03 00

5

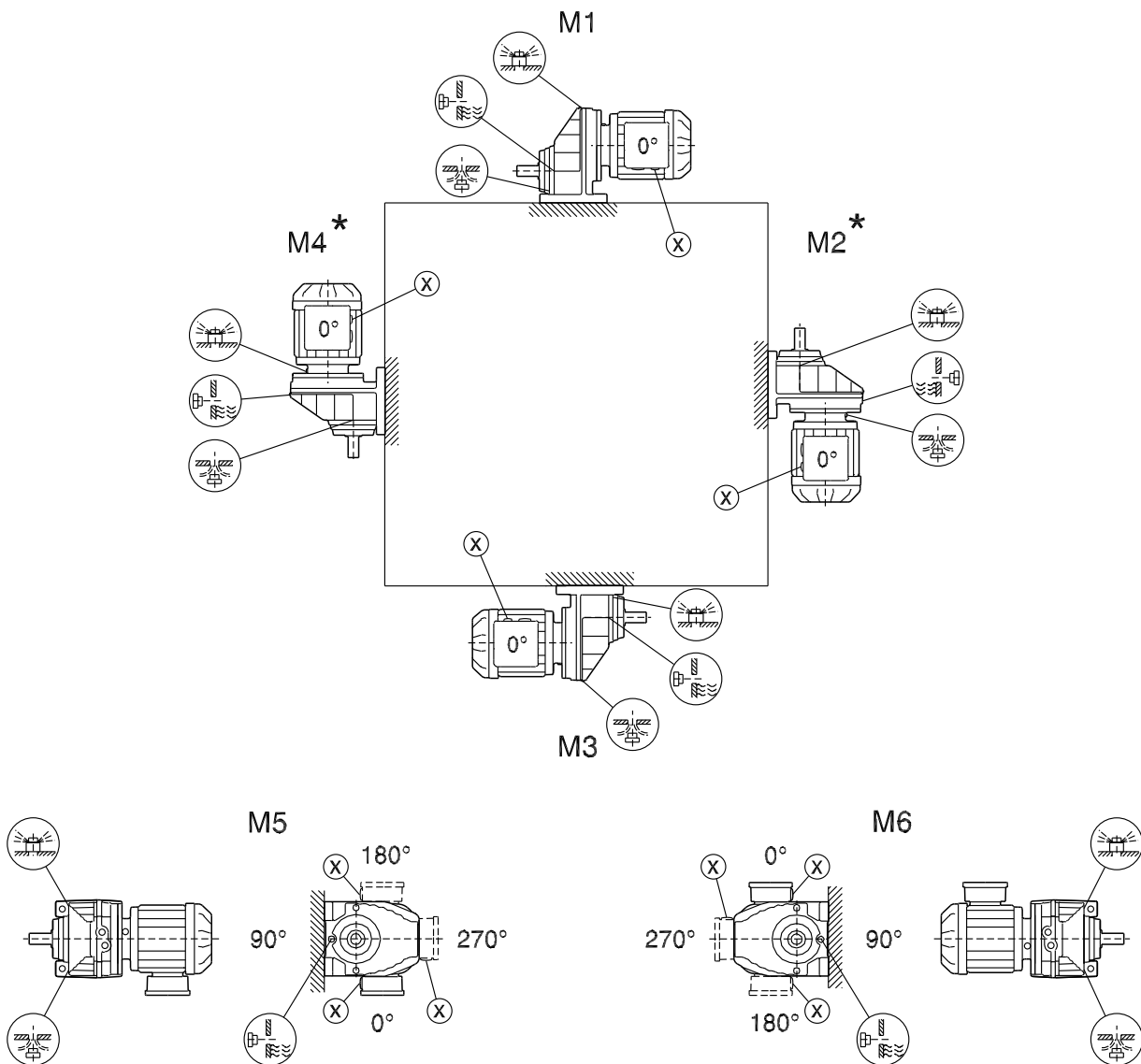
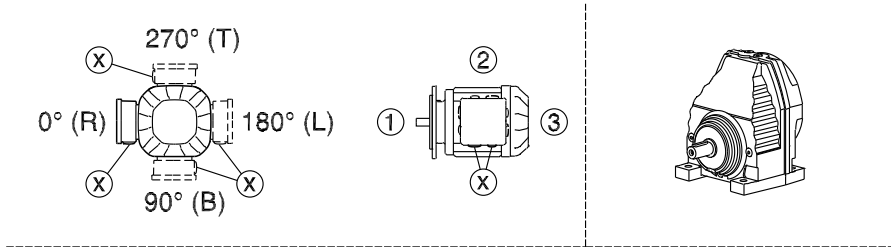

* (→ 60)

20272545/EN – 11/2015

5 Gear unit mounting positions and order information

Mounting position sheets

RXF57-RXF107

04 044 03 00

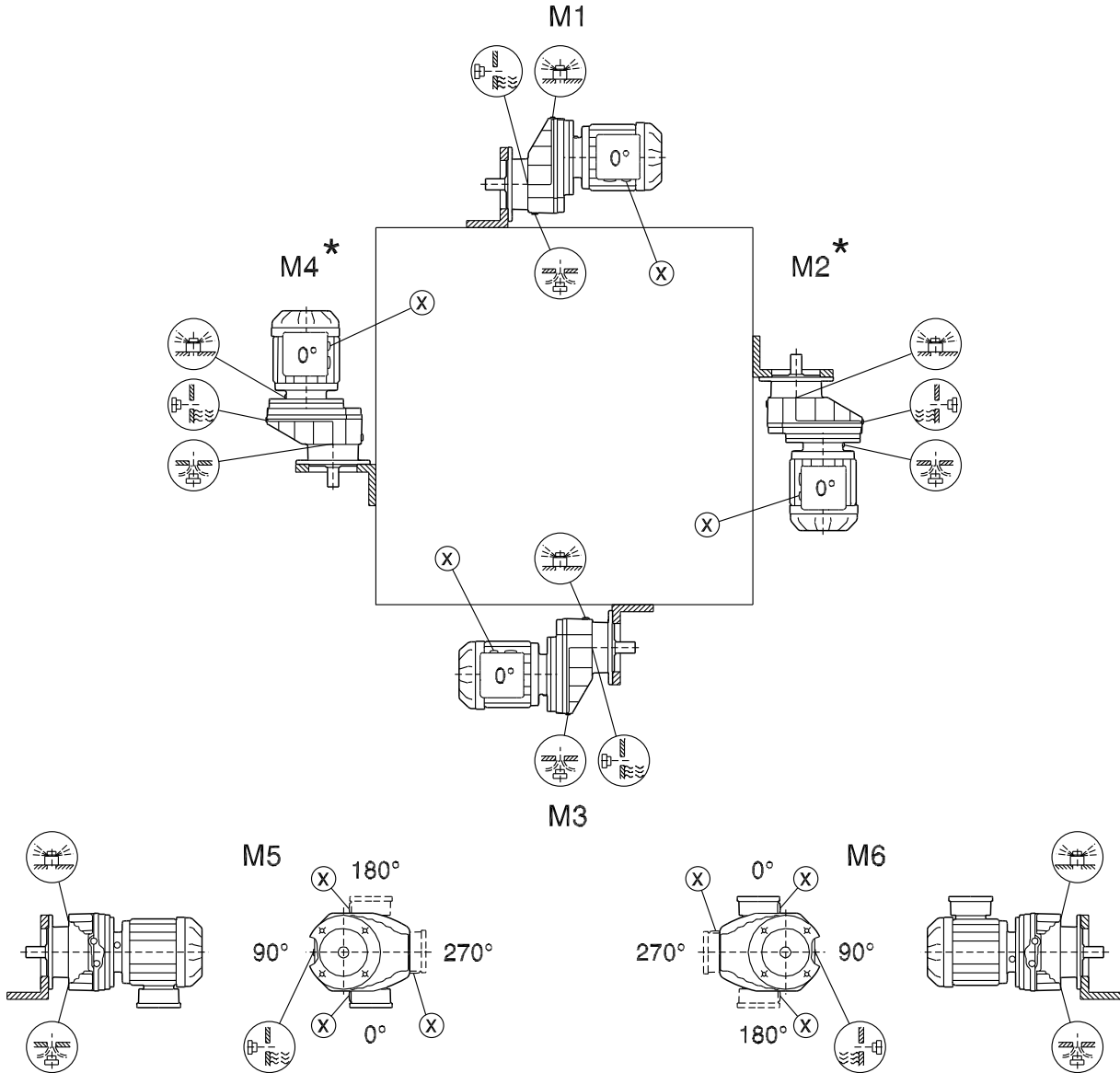
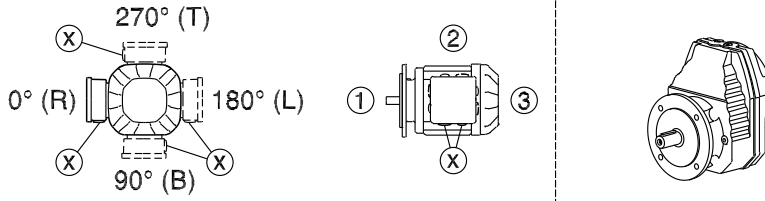

* (→ 60)

20272545/EN – 11/2015

R07-R167

04 040 04 00

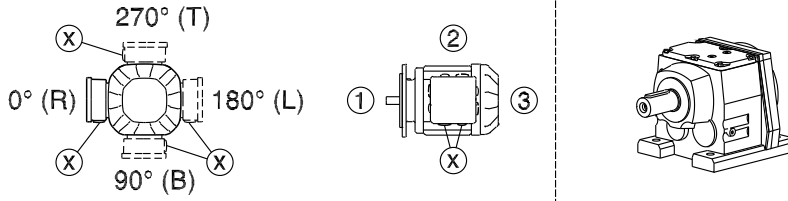

5

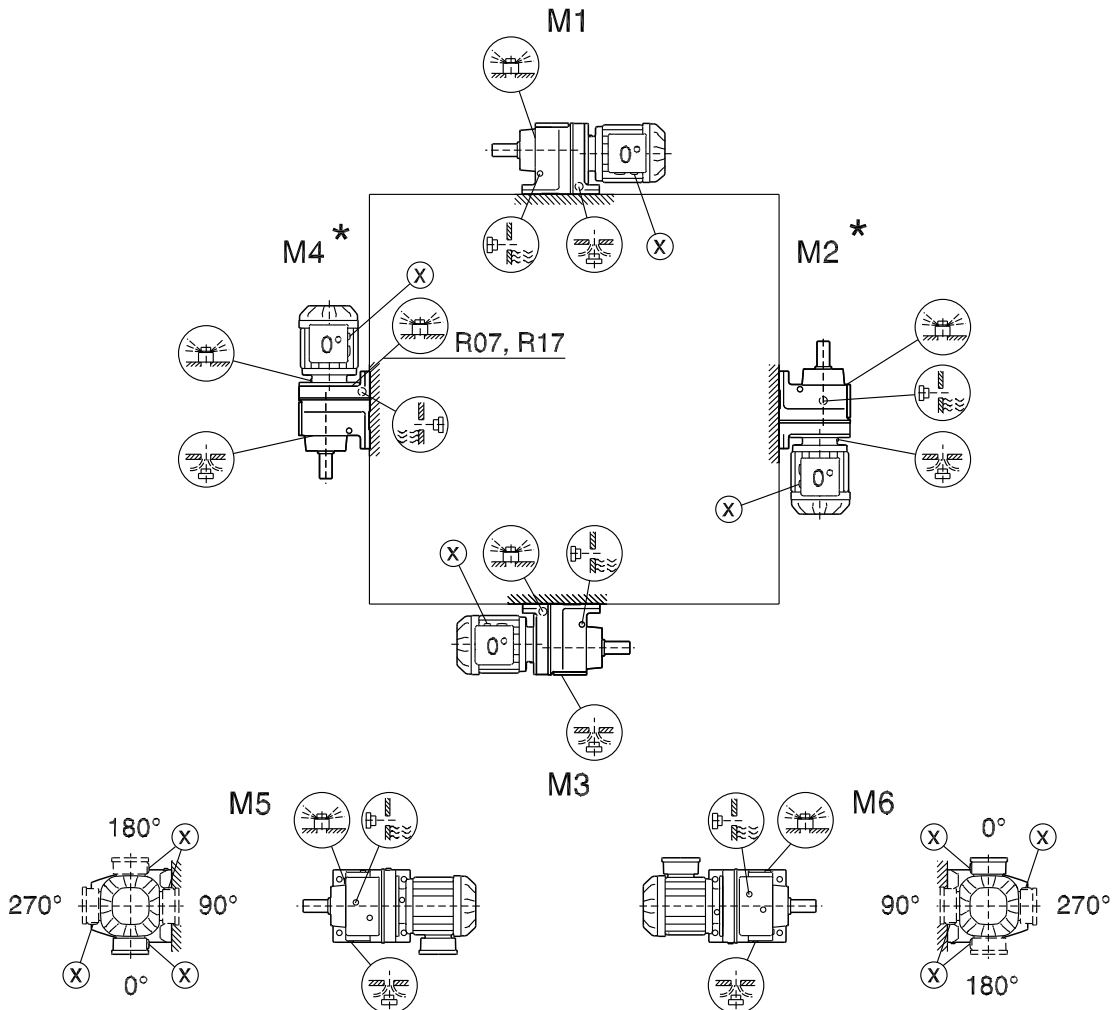

R07		M1, M2, M3, M5, M6
R17, R27		M1, M3, M5, M6
R07, R17, R27		
R47, R57		M5

* (→ 60)

Also refer to the information in chapter "Overhung and axial loads" (→ 46).

5 Gear unit mounting positions and order information

Mounting position sheets

RF07-RF167, RZ07-RZ87

04 041 04 00

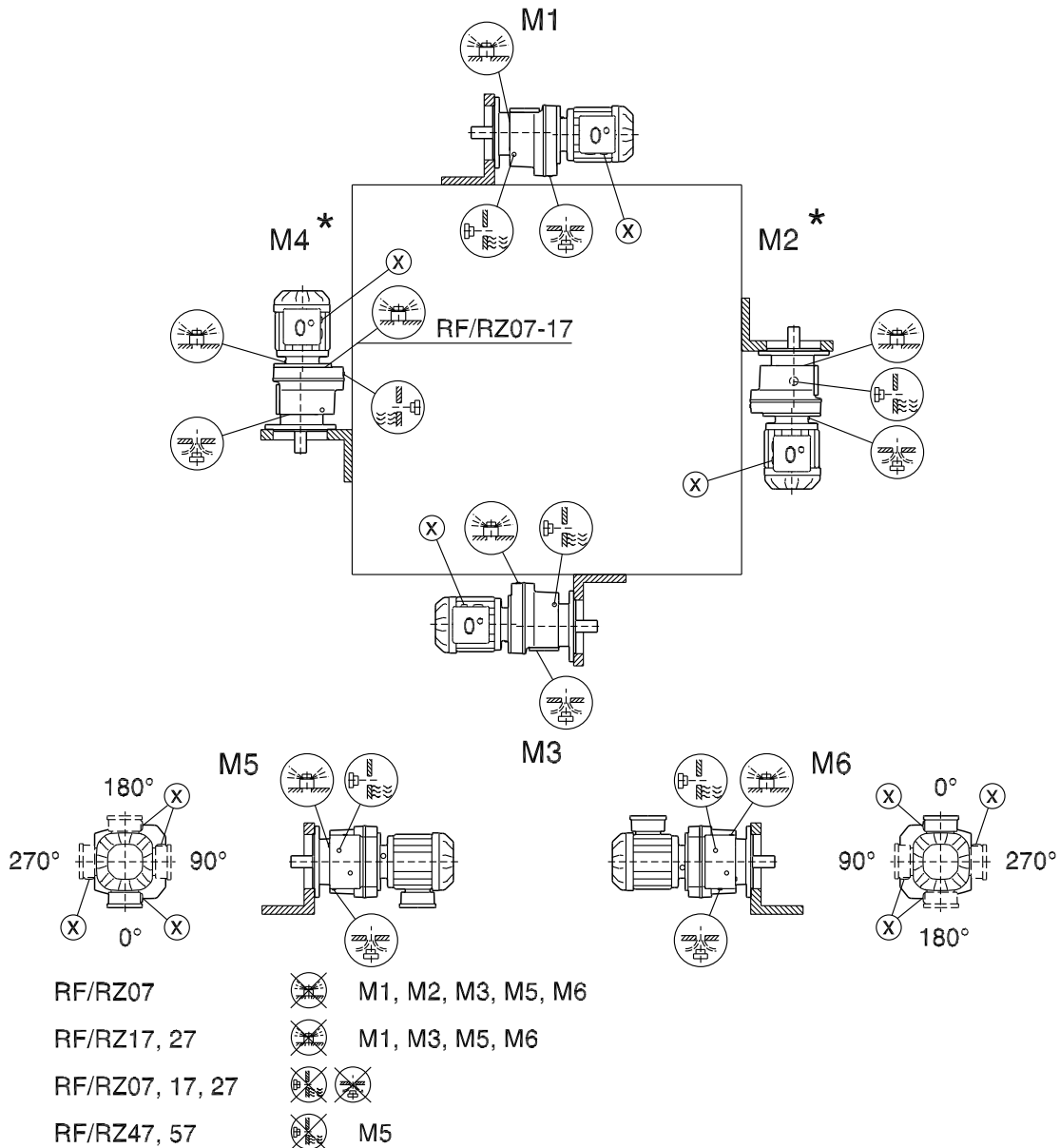
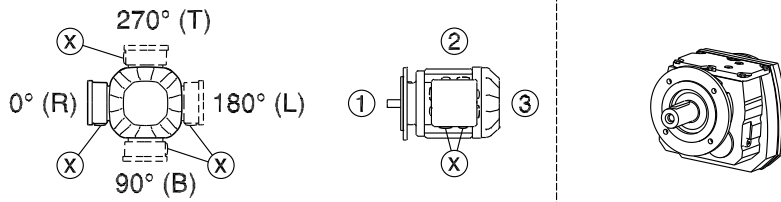

* (→ 60)

2022545/EN – 11/2015

R07F-R87F

04 042 04 00

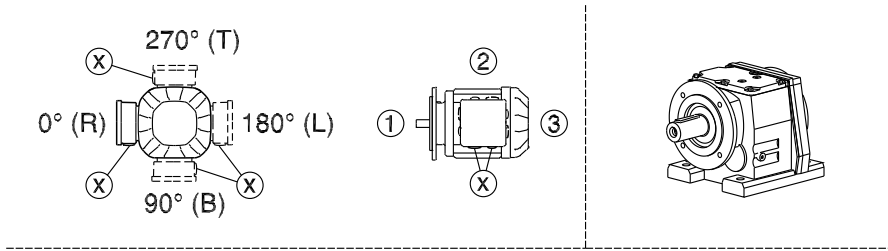

5

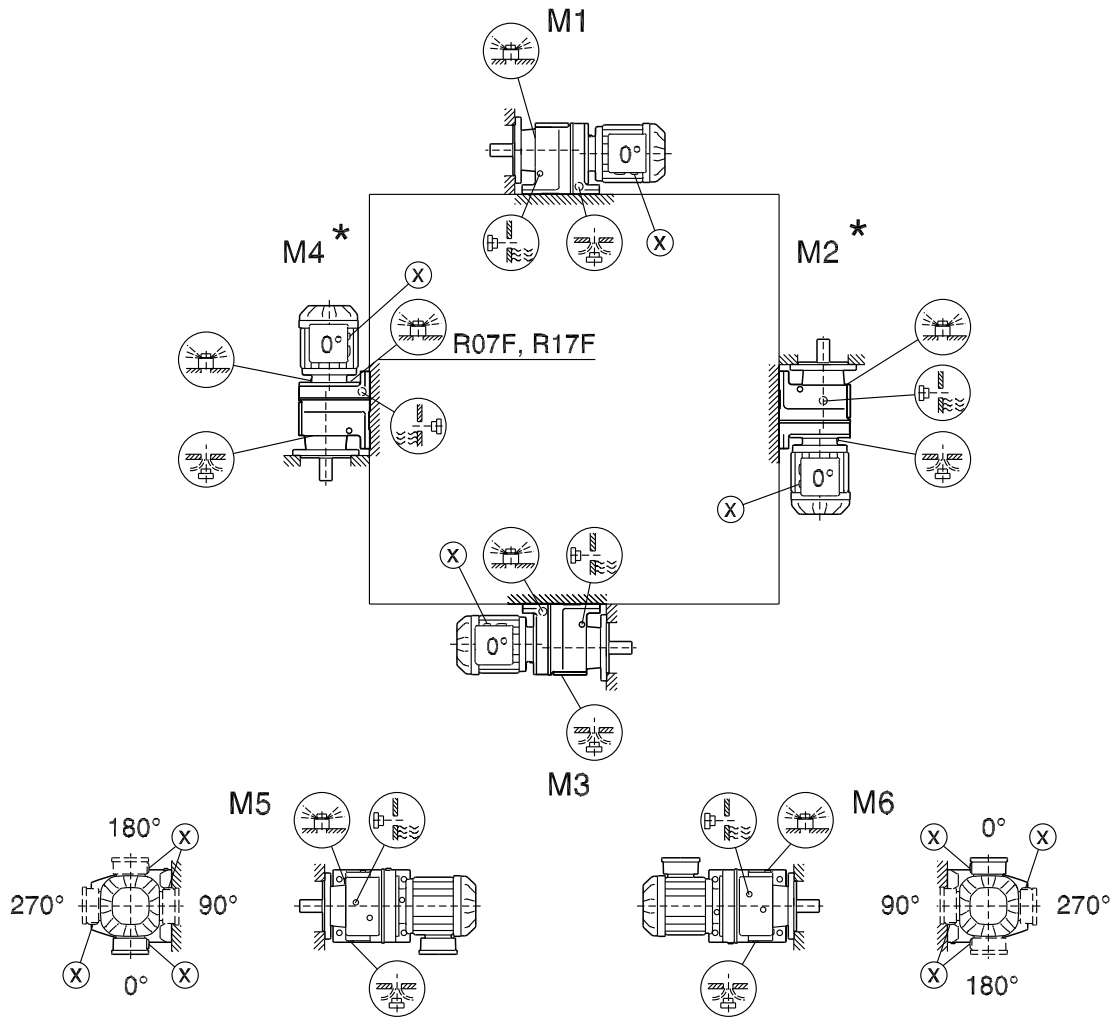

- | | |
|------------------|------------------------|
| R07F | M1, M2, M3, M5, M6 |
| R17F, R27F | M1, M3, M5, M6 |
| R07F, R17F, R27F | M1, M2, M3, M4, M5, M6 |
| R47F, R57F | M5 |

* (→ 60)

Also refer to the information in chapter "Overhung and axial loads" (→ 46).

20272545/EN – 11/2015

5 Gear unit mounting positions and order information

Mounting position sheets

5.4.2 Mounting positions of parallel-shaft helical gearmotors

F/FA..B/FH27B-157B, FV27B-107B

42 042 04 00

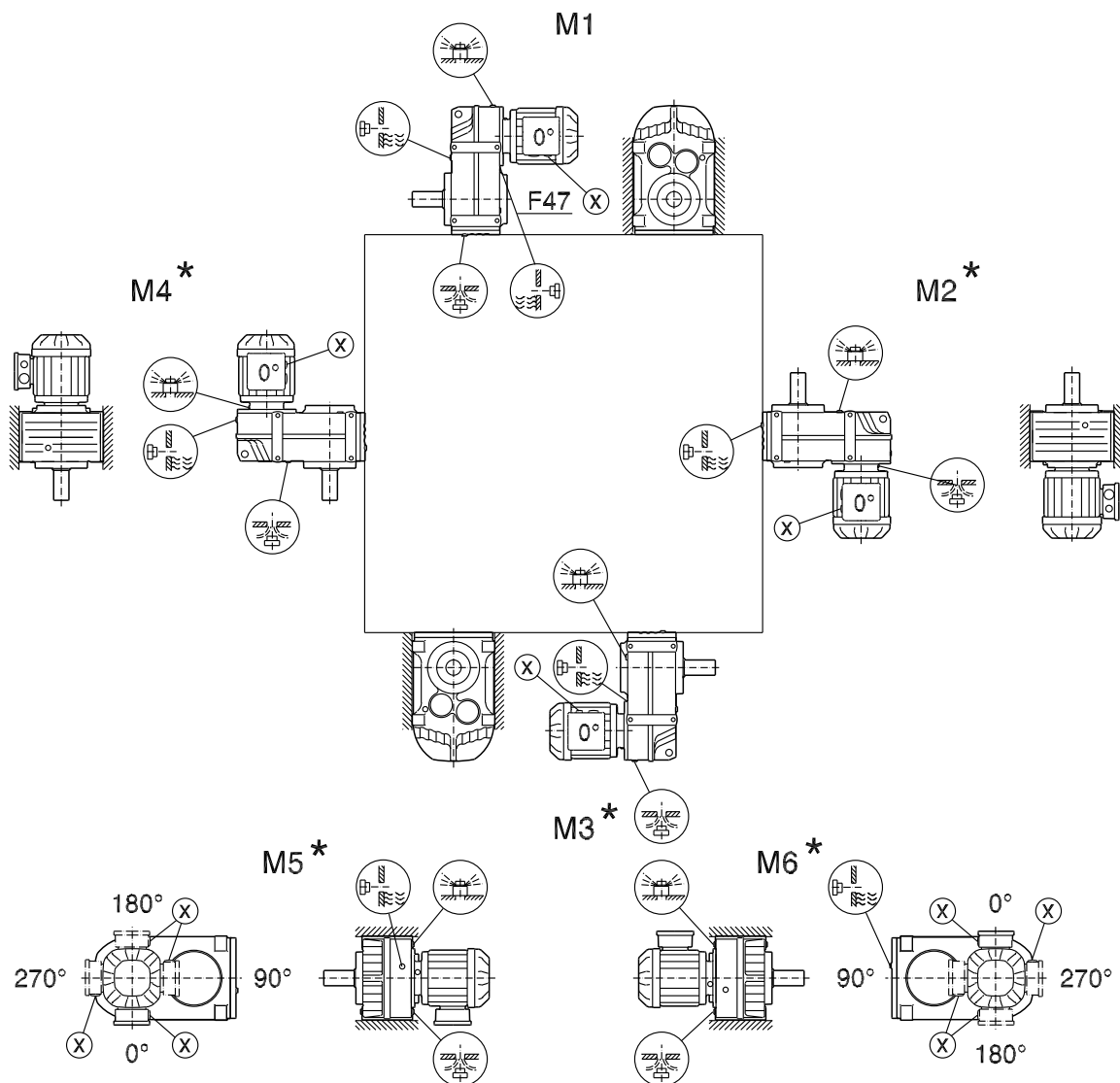
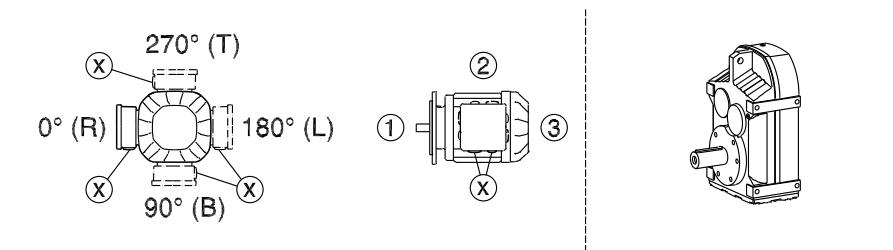

- F..27 M1, M3, M5, M6
- F..27 M1 - M6
- F..27 M1, M3, M5, M6

* (→ 60)

2022545/EN – 11/2015

FF/FAF/FHF/FZ/FAZ/FHZ27-157, FVF/FVZ27-107

42 043 04 00

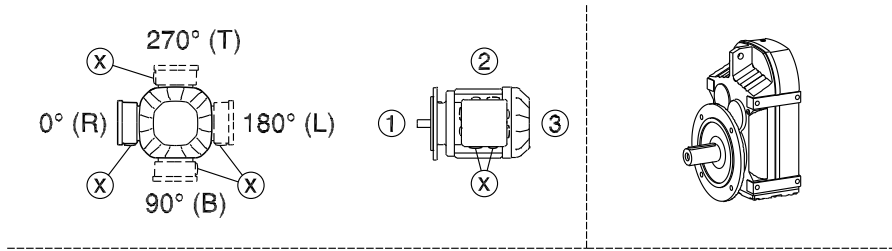

5

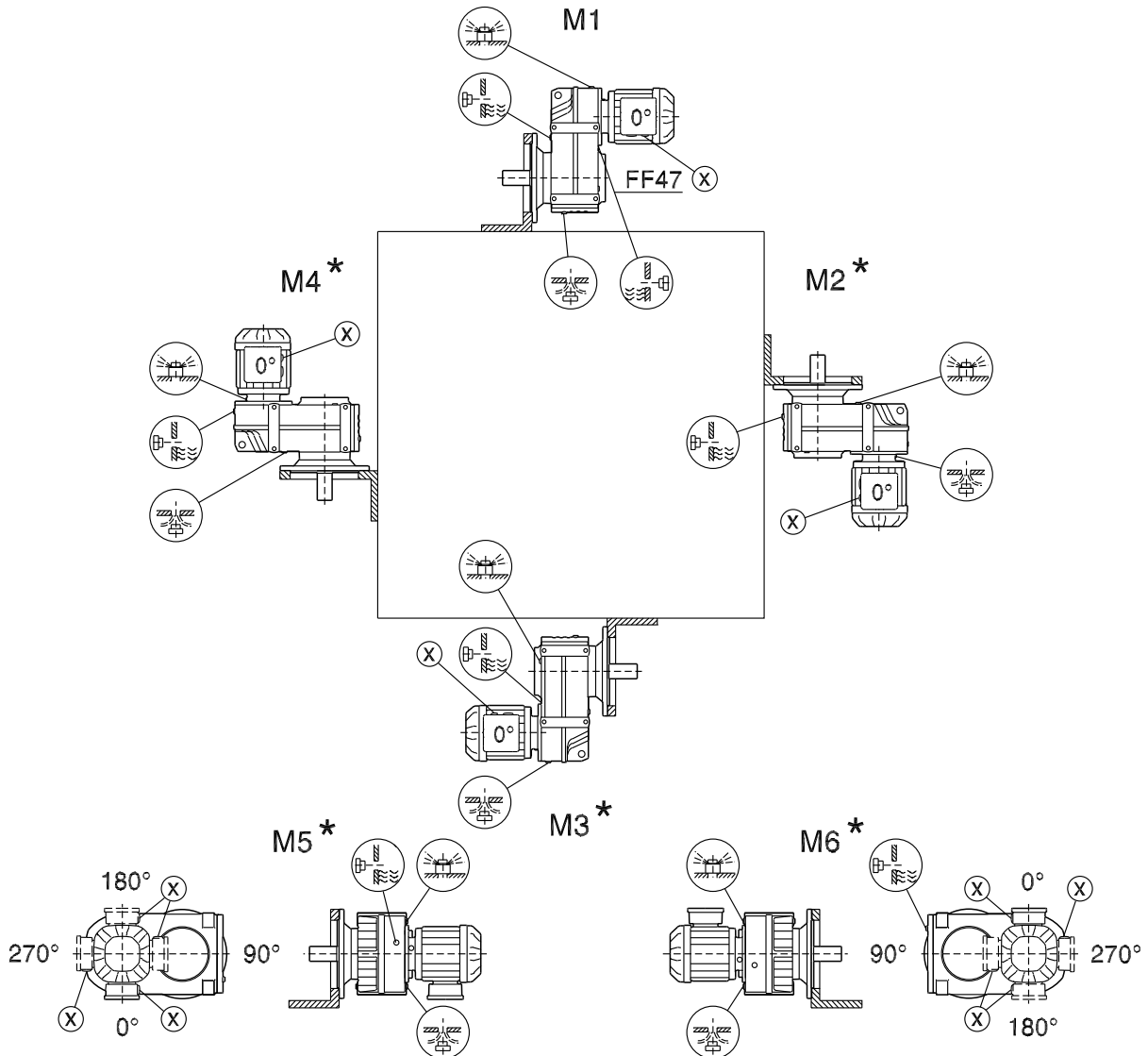

- F..27 M1, M3, M5, M6
- F..27 M1 - M6
- F..27 M1, M3, M5, M6

* (→ 60)

20272545/EN – 11/2015

5 Gear unit mounting positions and order information

Mounting position sheets

FA/FH27-157, FV27-107, FT37-97

42 044 04 00

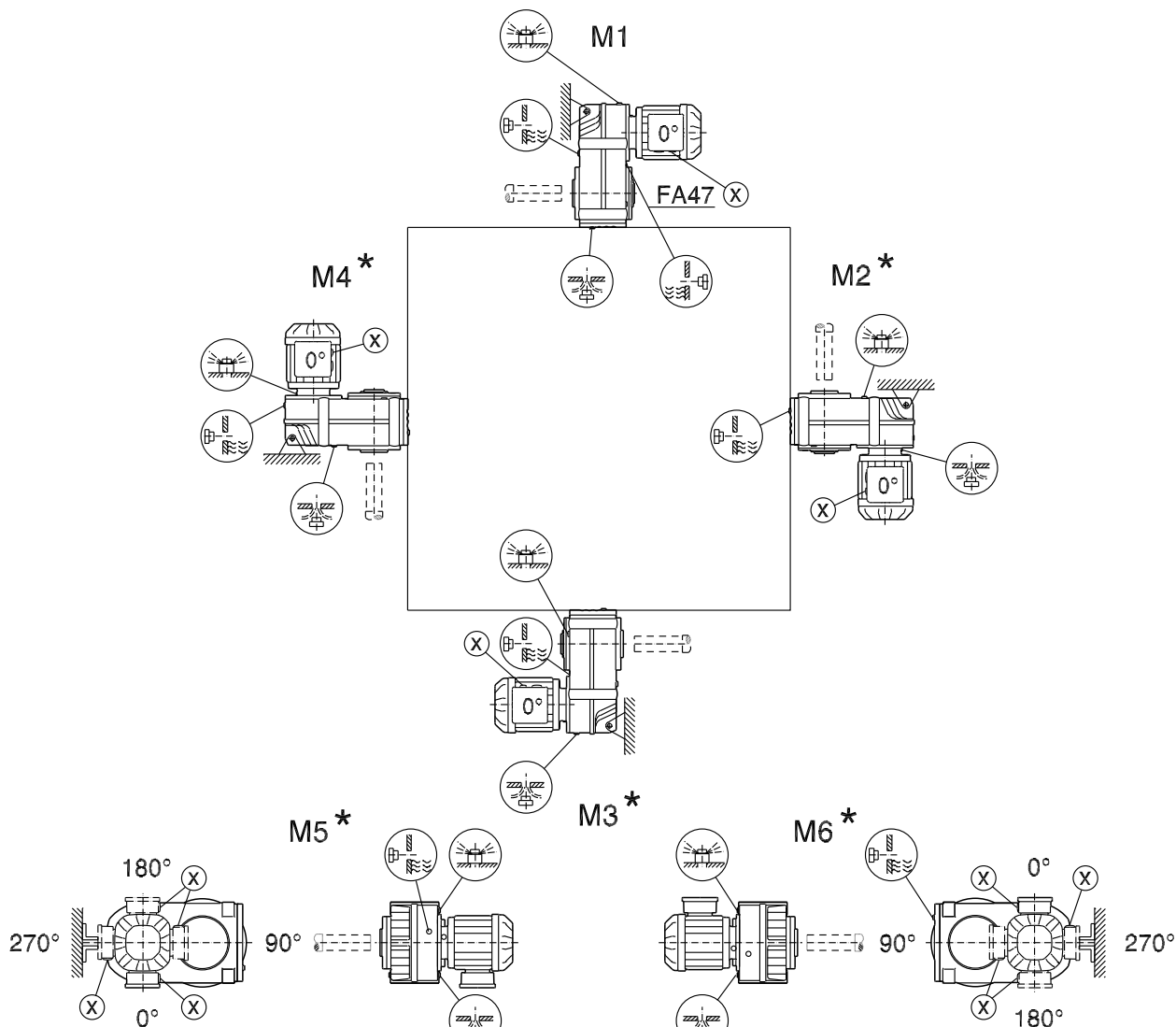
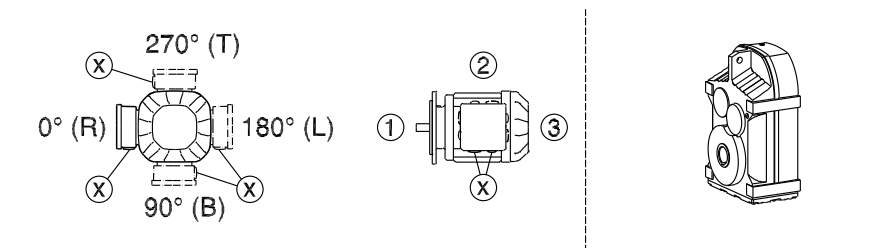

- F..27 M1, M3, M5, M6
- F..27 M1 - M6
- F..27 M1, M3, M5, M6

* (→ 60)

20272545/EN - 11/2015

5.4.3 Mounting positions of helical-bevel gearmotors

K/KA..B/KH19B-29B

33 023 00 15

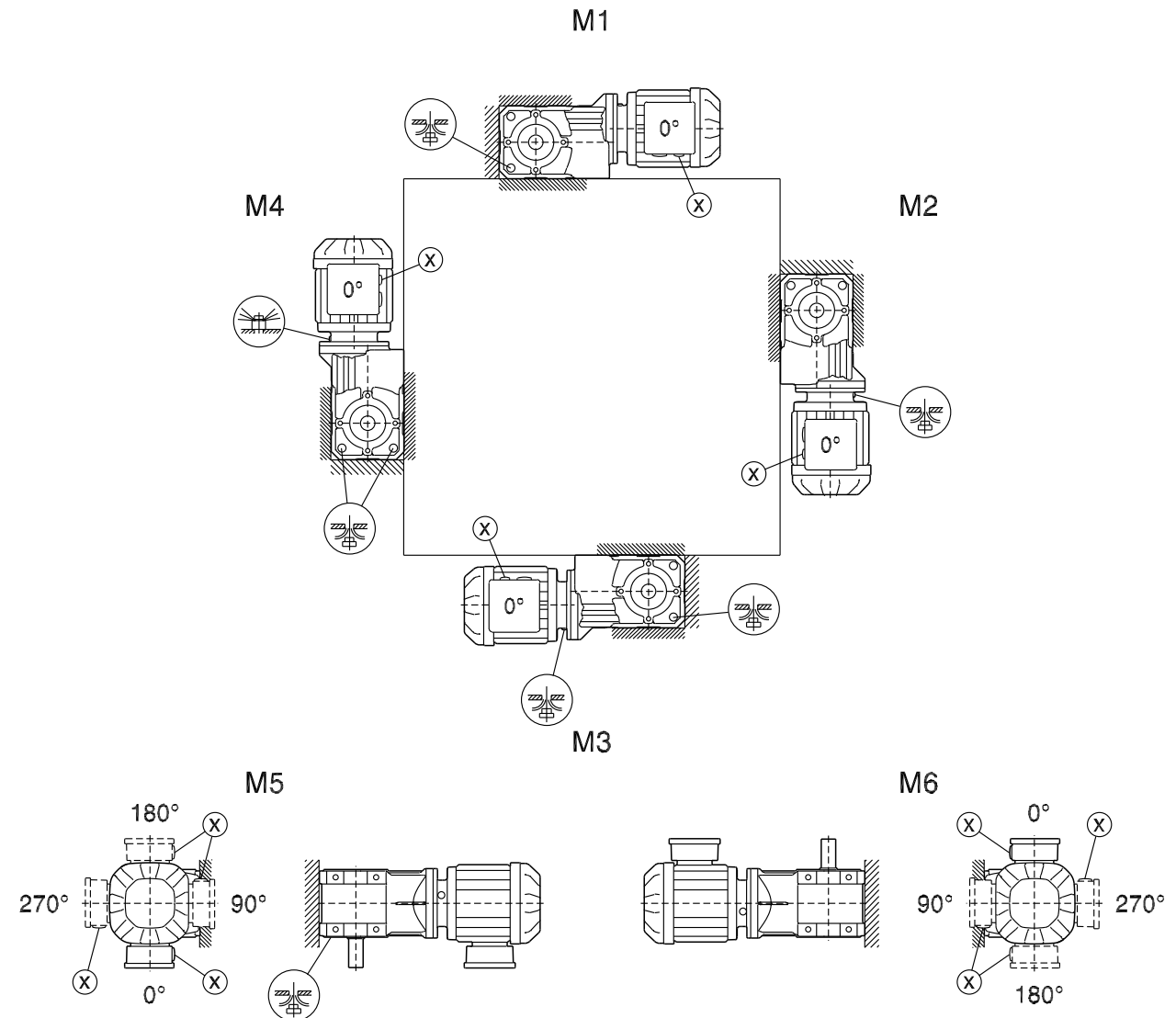
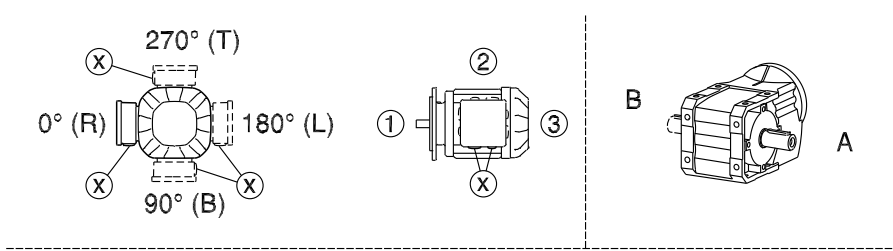

Also refer to the information in chapter "Overhung and axial loads" (→ 46).

20272545/EN – 11/2015

5 Gear unit mounting positions and order information

Mounting position sheets

KF..B/KAF..B/KHF19B-29B

33 024 00 15

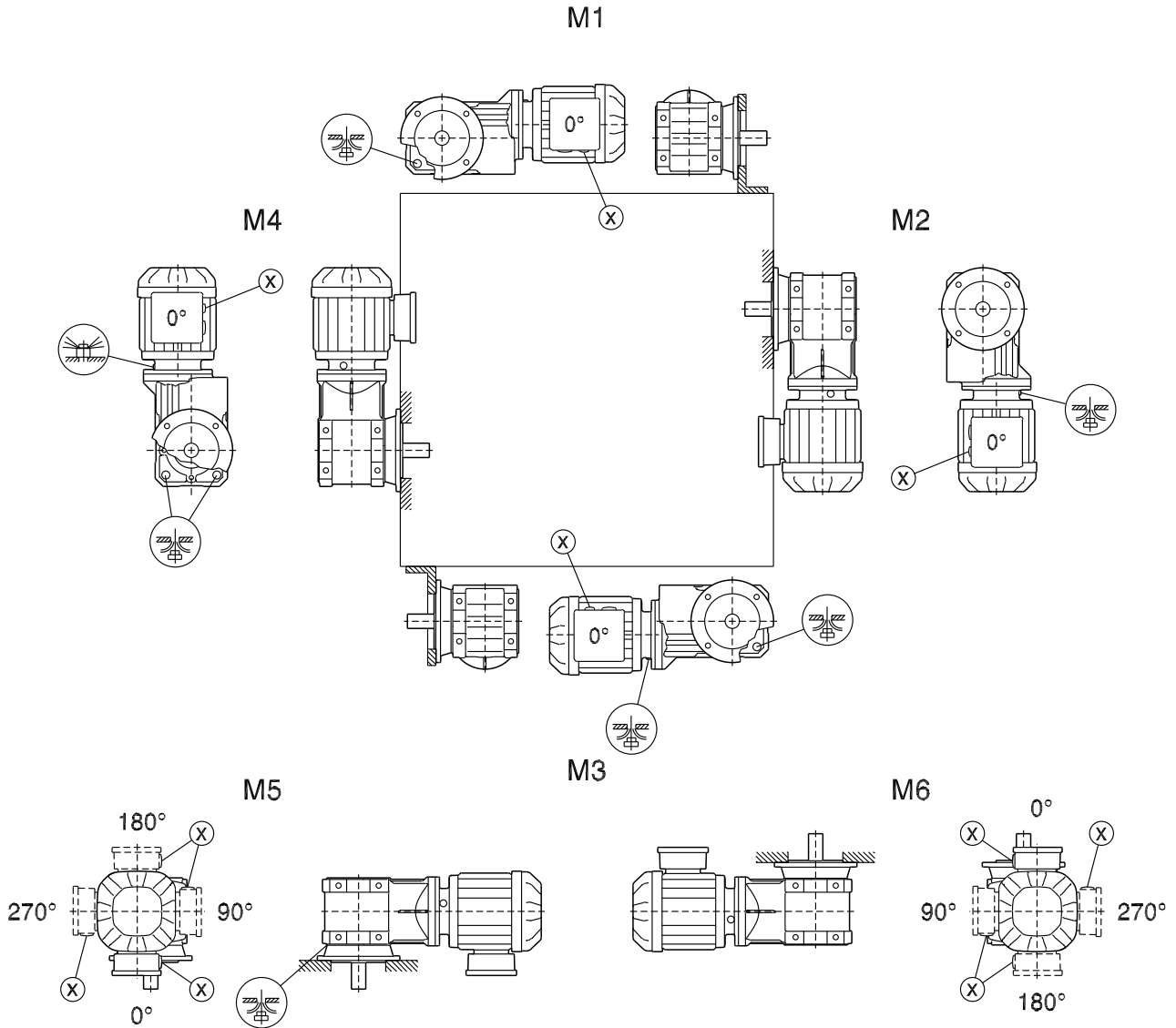
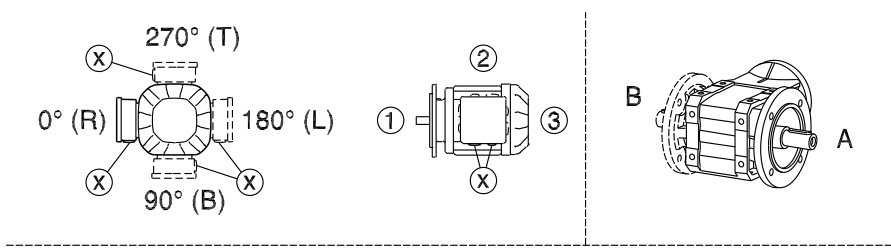

Also refer to the information in chapter "Overhung and axial loads" (→ 46).

20272545/EN – 11/2015

KA..B/KH19B-29B

33 025 00 15

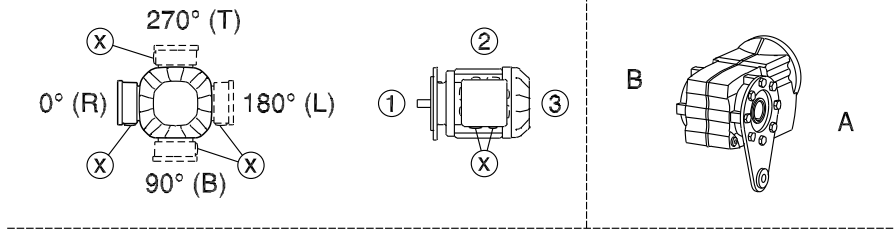

5

M1

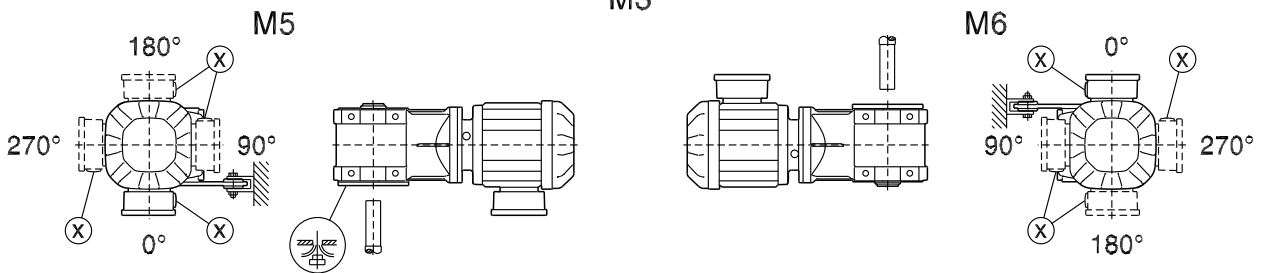
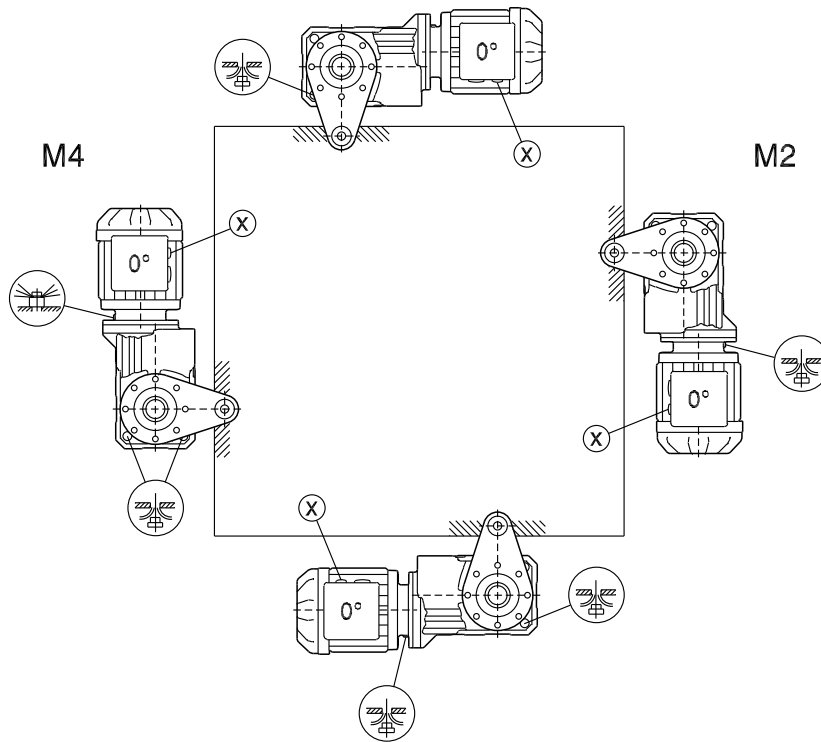

Also refer to the information in chapter "Overhung and axial loads" (→ 46).

20272545/EN – 11/2015

5 Gear unit mounting positions and order information

Mounting position sheets

KF/KAF/KHF19-29

33 026 00 15

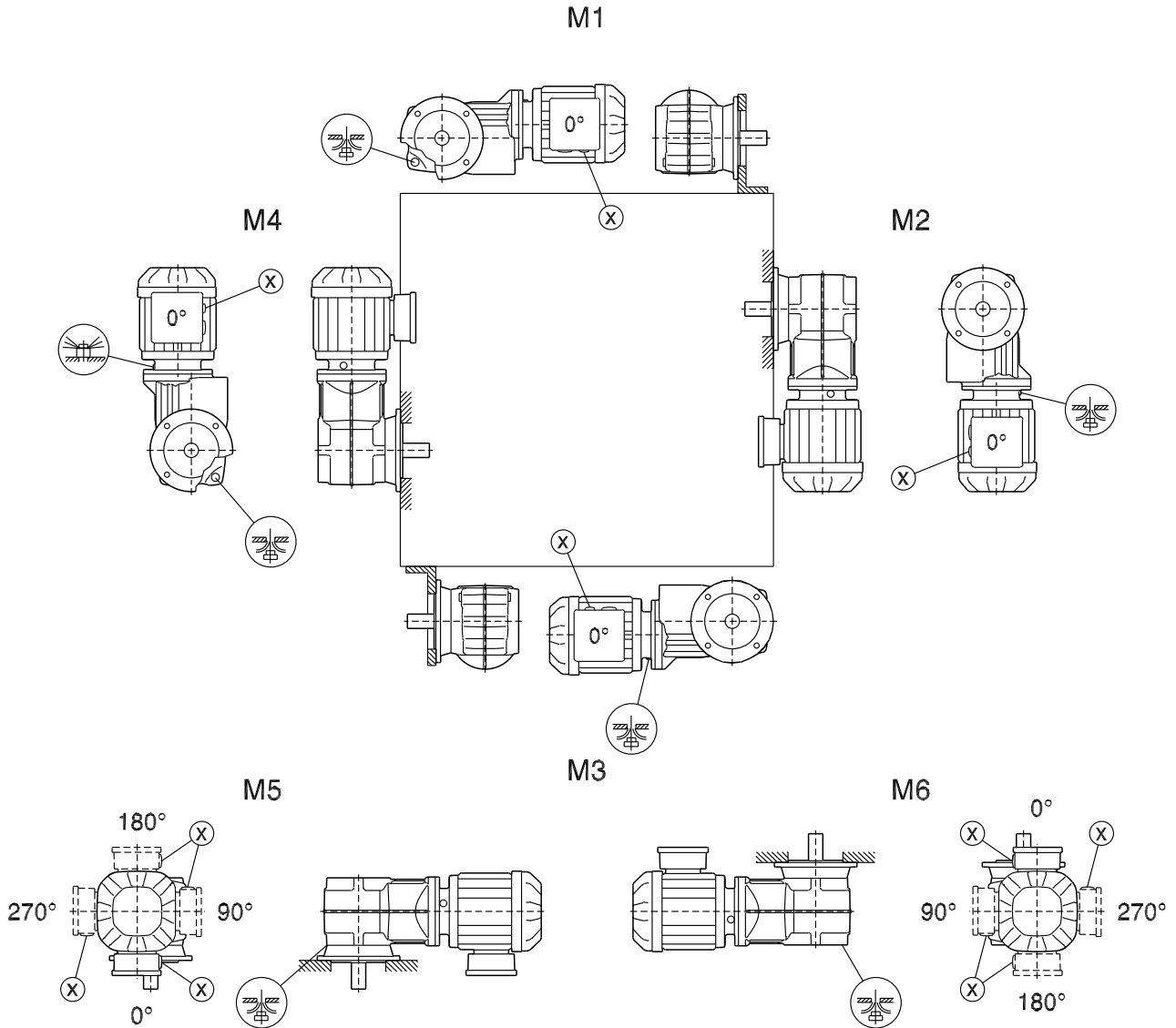
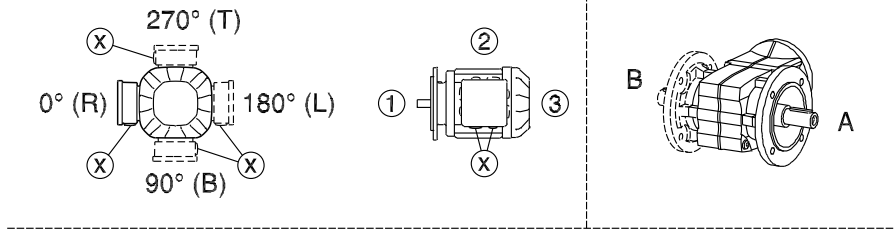

Also refer to the information in chapter "Overhung and axial loads" (→ 46).

20272545/EN – 11/2015

KA/KH19-29

33 027 00 15

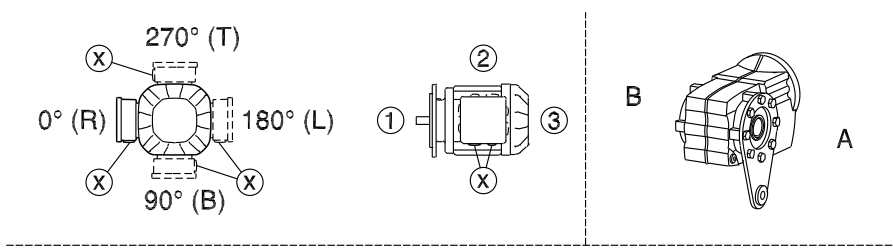

5

M1

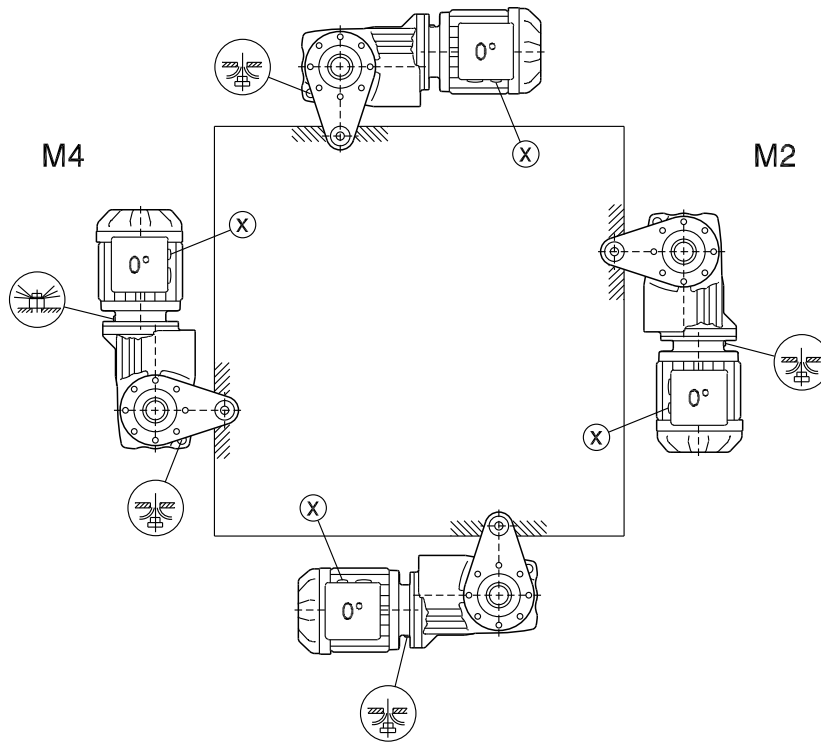

M5

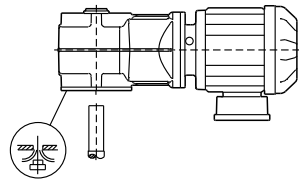
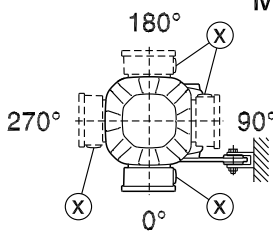

M3

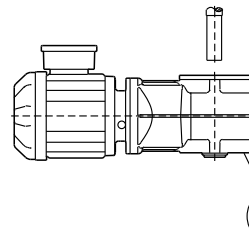

M6

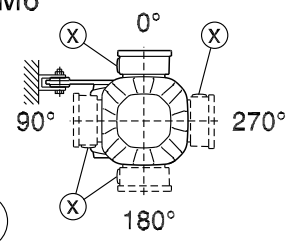

20272545/EN – 11/2015

5 Gear unit mounting positions and order information

Mounting position sheets

K39-49

33 092 01 14

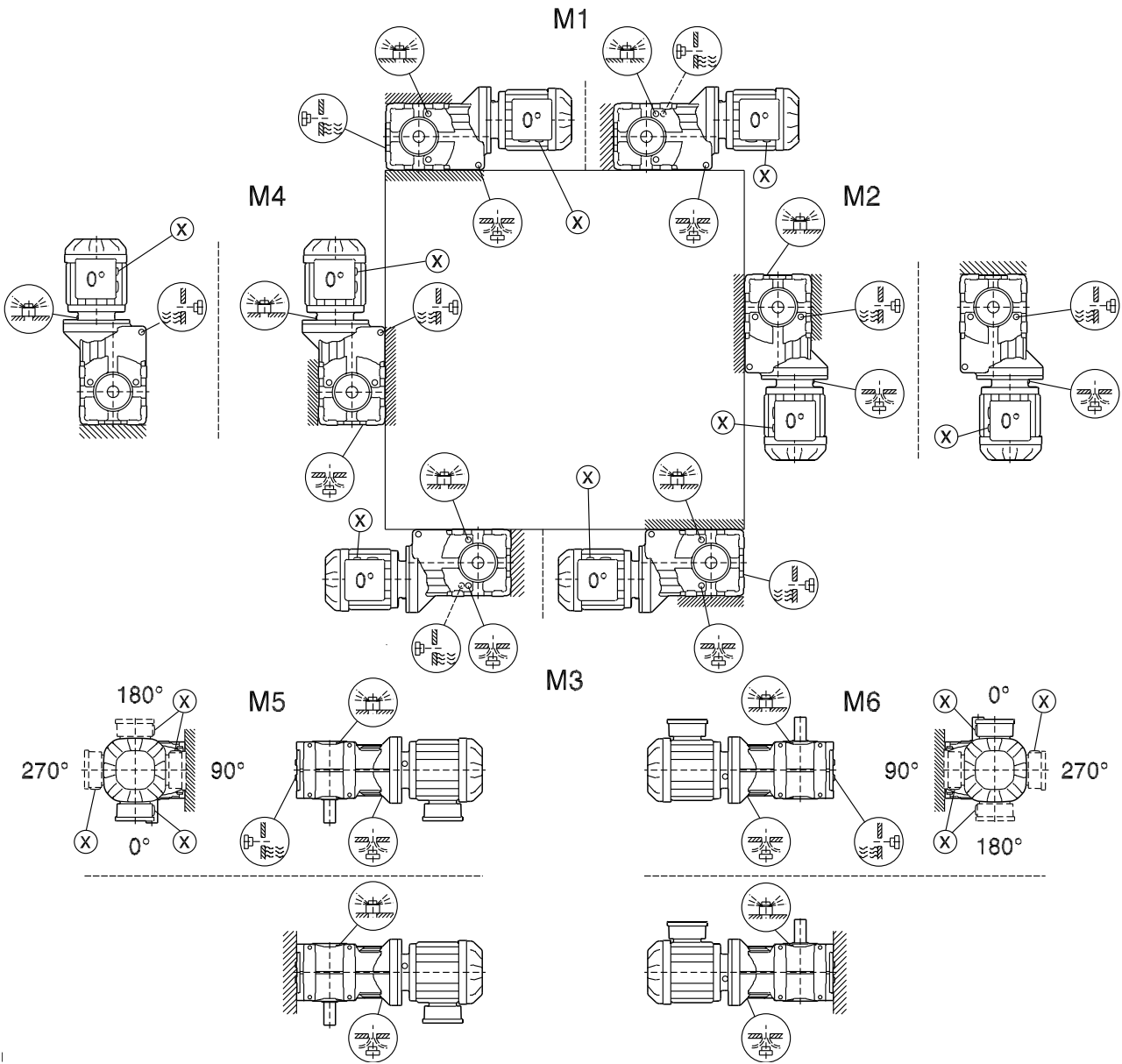
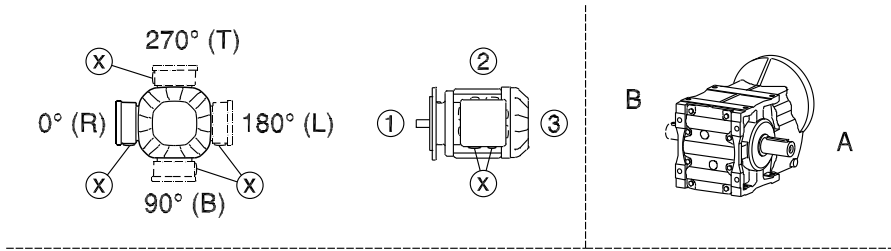

KF/KAF39-49

33 093 00 14

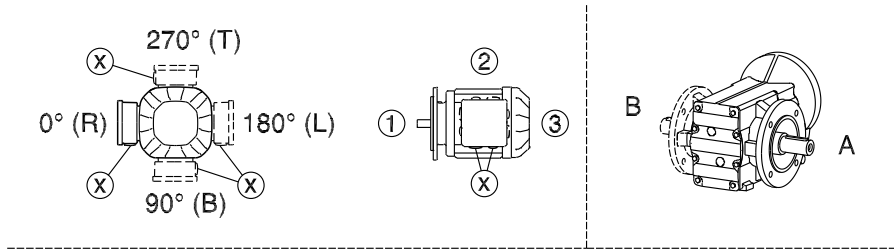

5

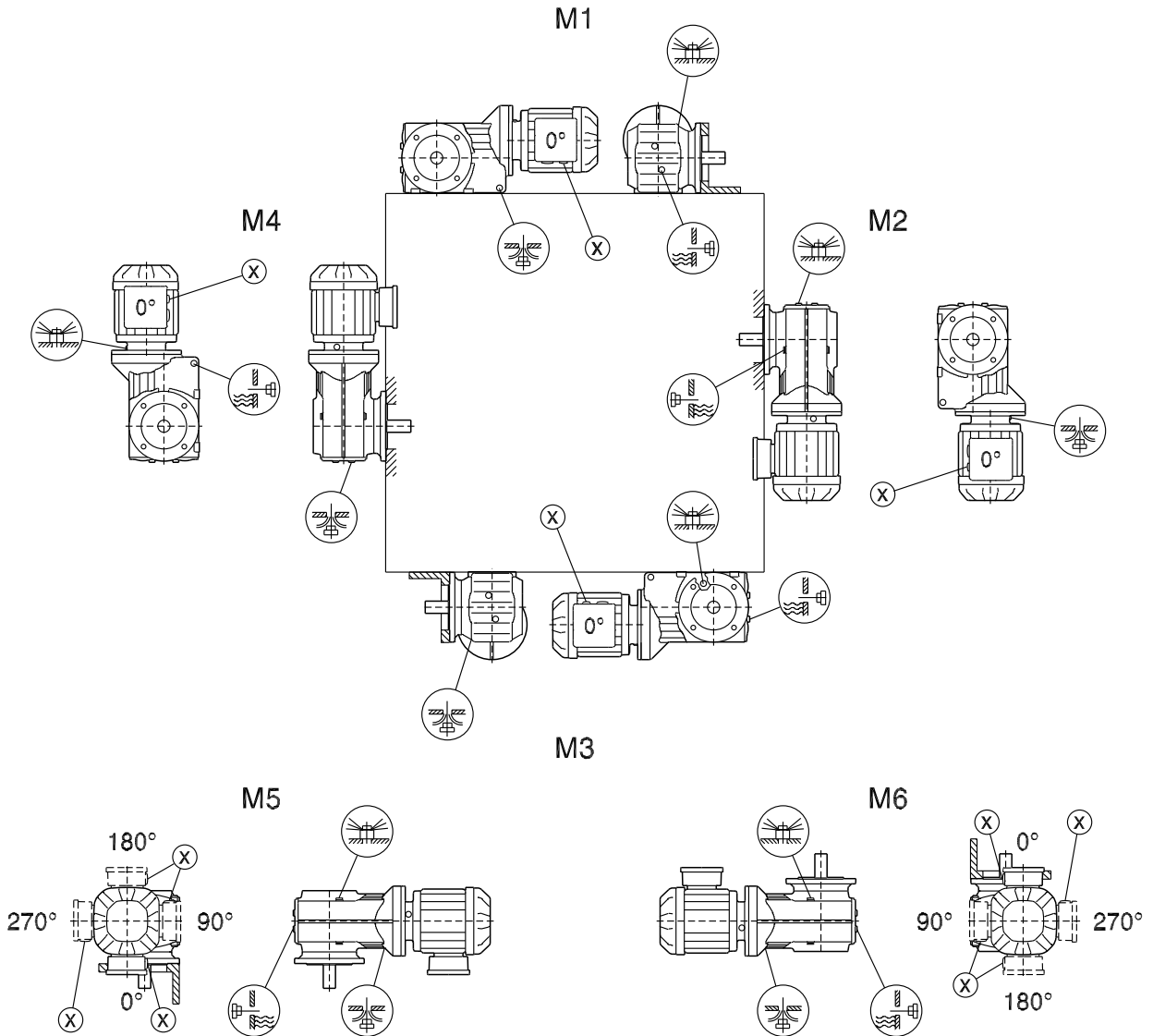

20272545/EN – 11/2015

5 Gear unit mounting positions and order information

Mounting position sheets

KA/KT39-49

33 094 00 14

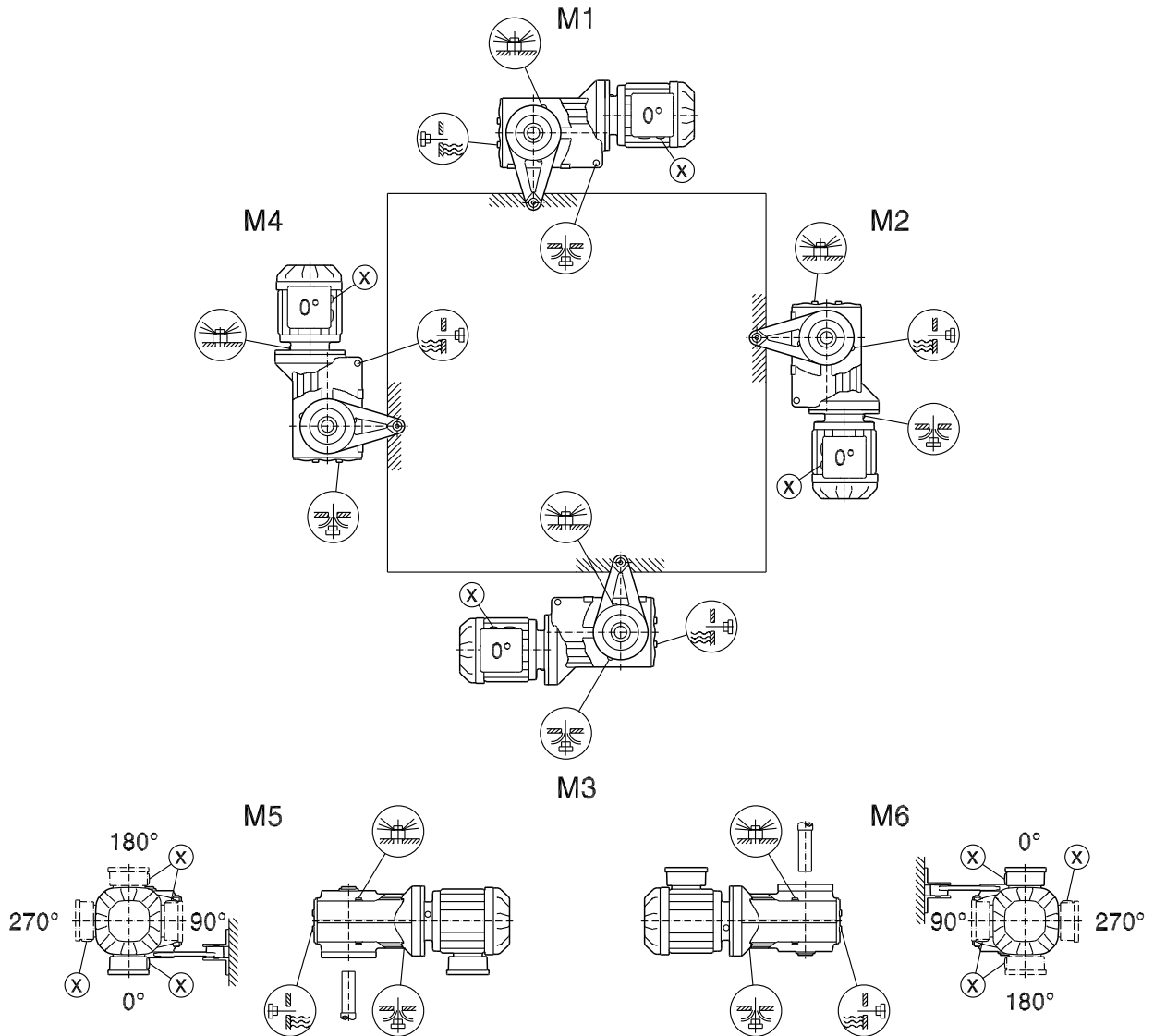
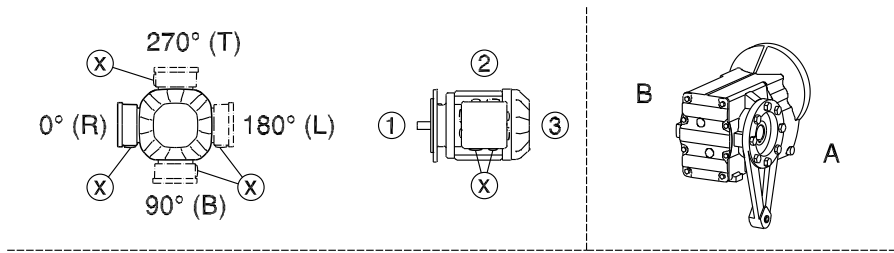

20272545/EN - 11/2015

K/KA..B/KH47B-157B, KV47B-107B

34 025 05 00

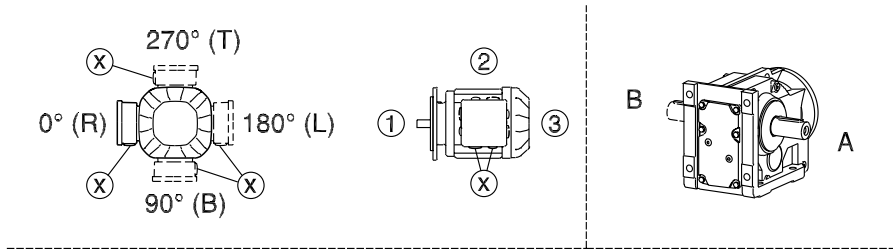

5

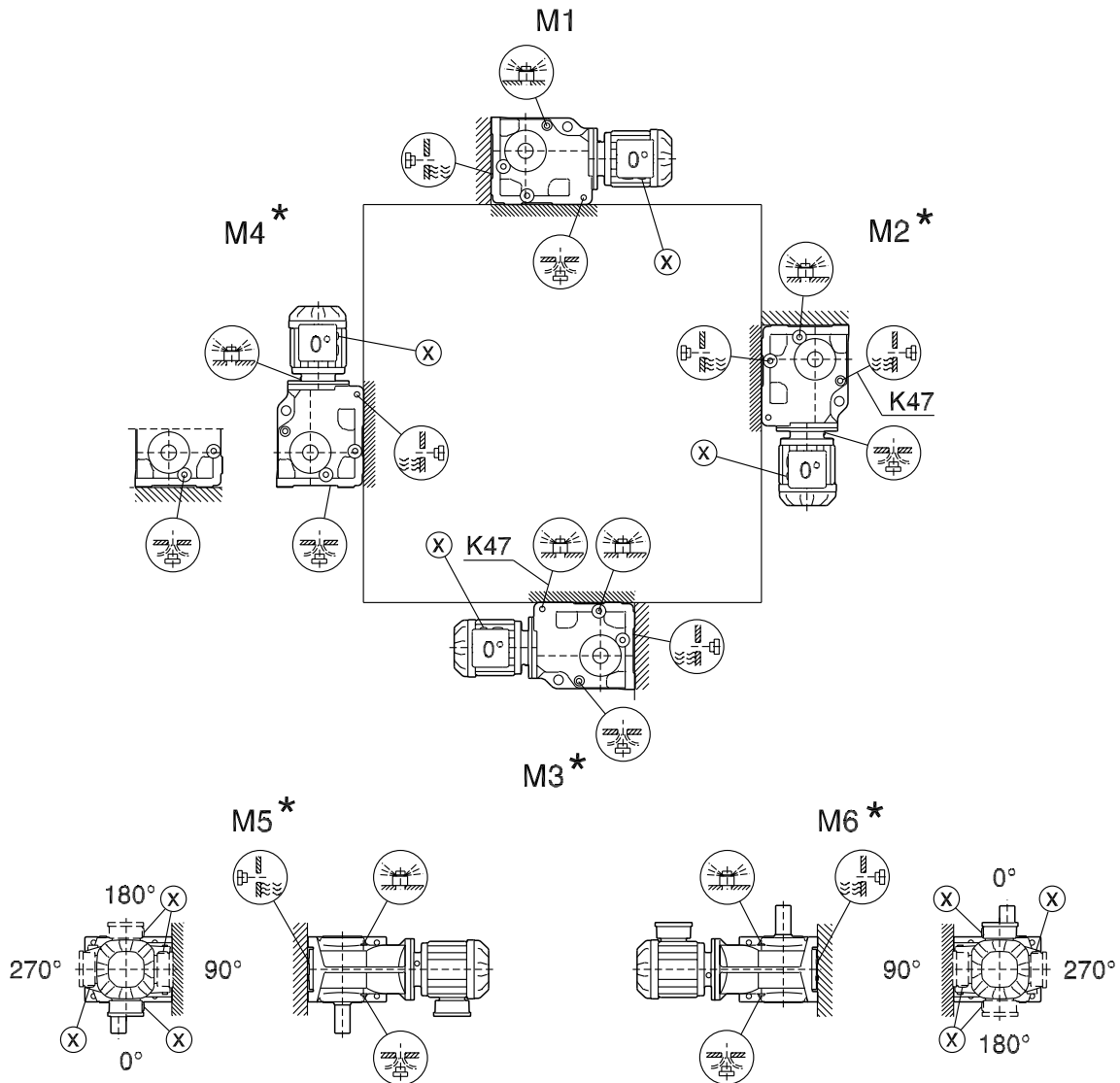

* (→ 60)

Also refer to the information in chapter "Overhung and axial loads" (→ 46).

20272545/EN – 11/2015

5 Gear unit mounting positions and order information

Mounting position sheets

K167-187, KH167B-187B

34 026 05 00

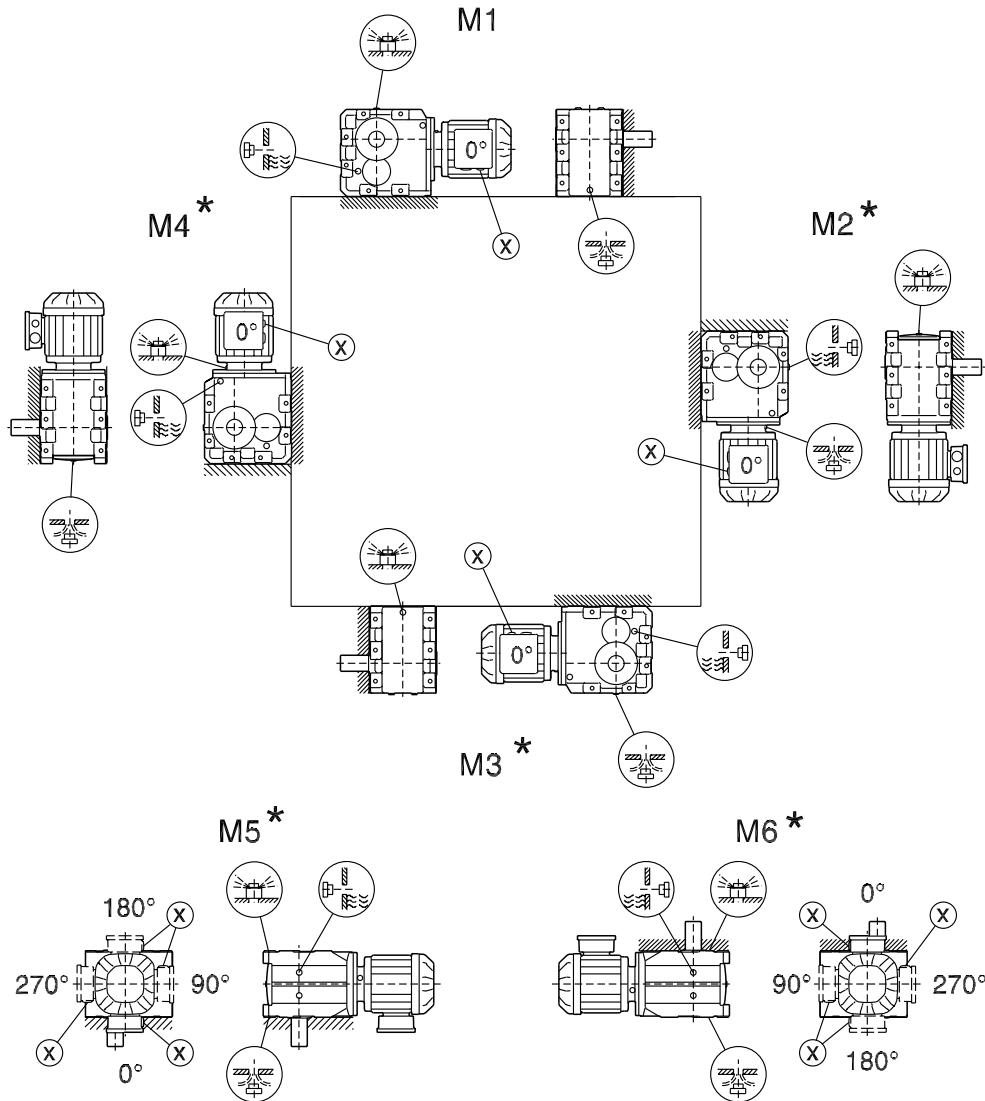
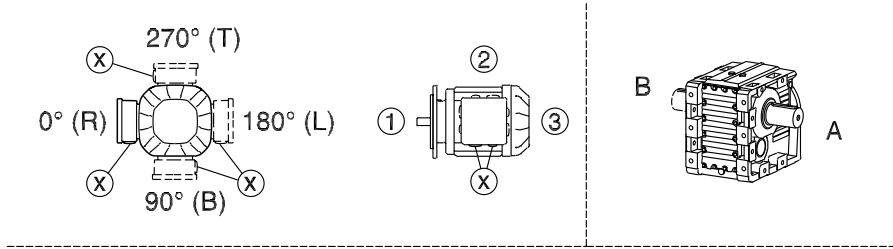

* (→ 60)

Also refer to the information in chapter "Overhung and axial loads" (→ 46).

KF/KAF/KHF/KZ/KAZ/KHZ37-157, KVF/KVZ37-107

34 027 04 00

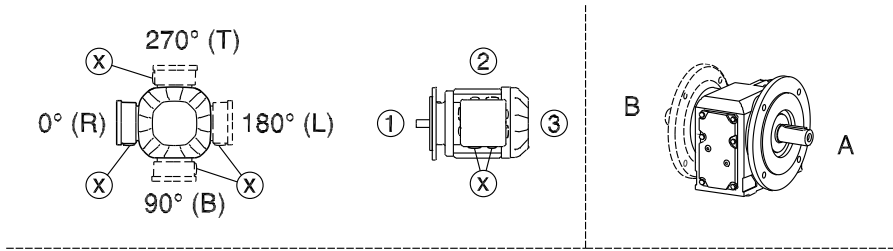

5

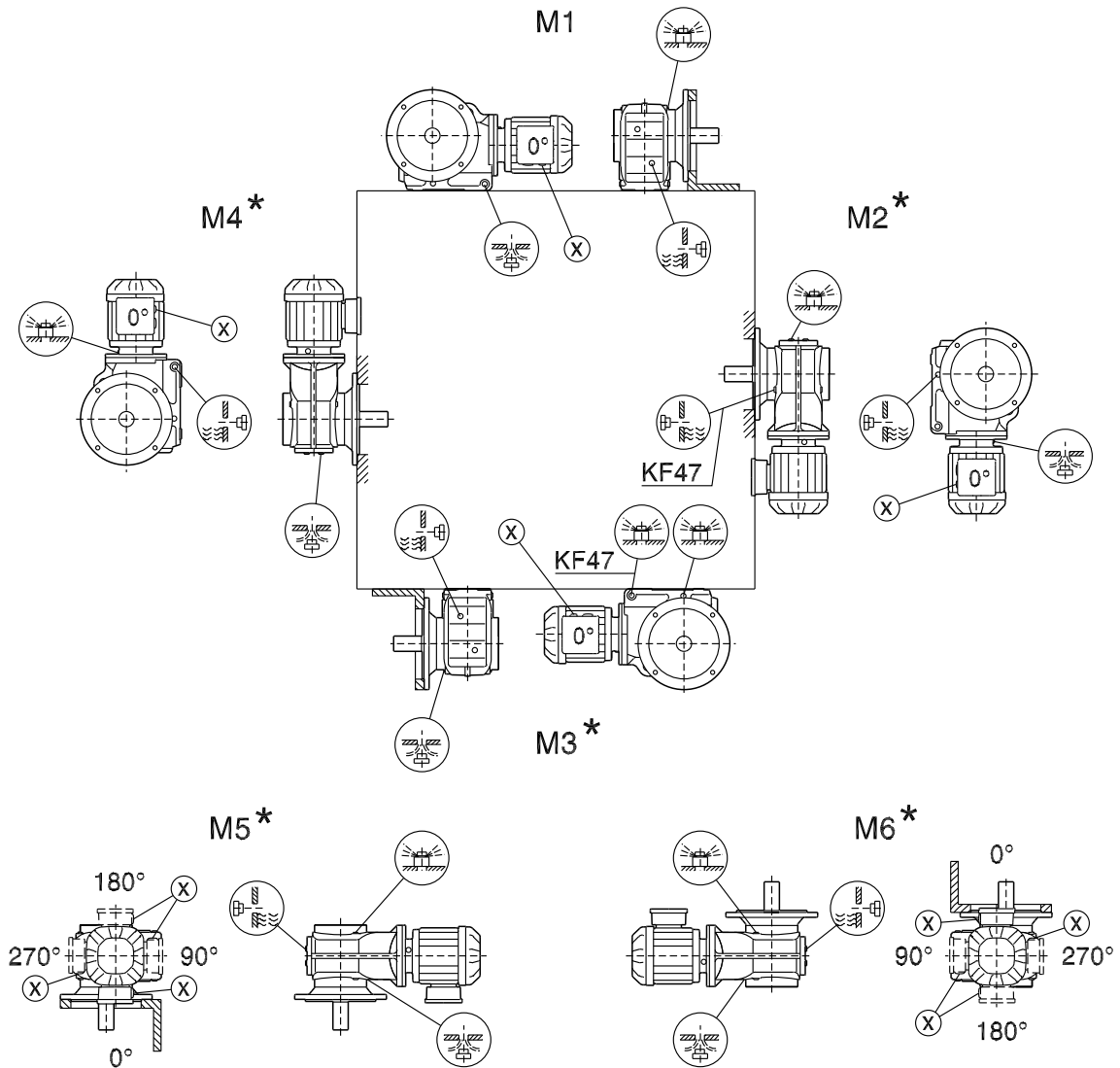

* (→ 60)

20272545/EN – 11/2015

5 Gear unit mounting positions and order information

Mounting position sheets

KA/KH37-157, KV37-107, KT37-97

39 025 05 00

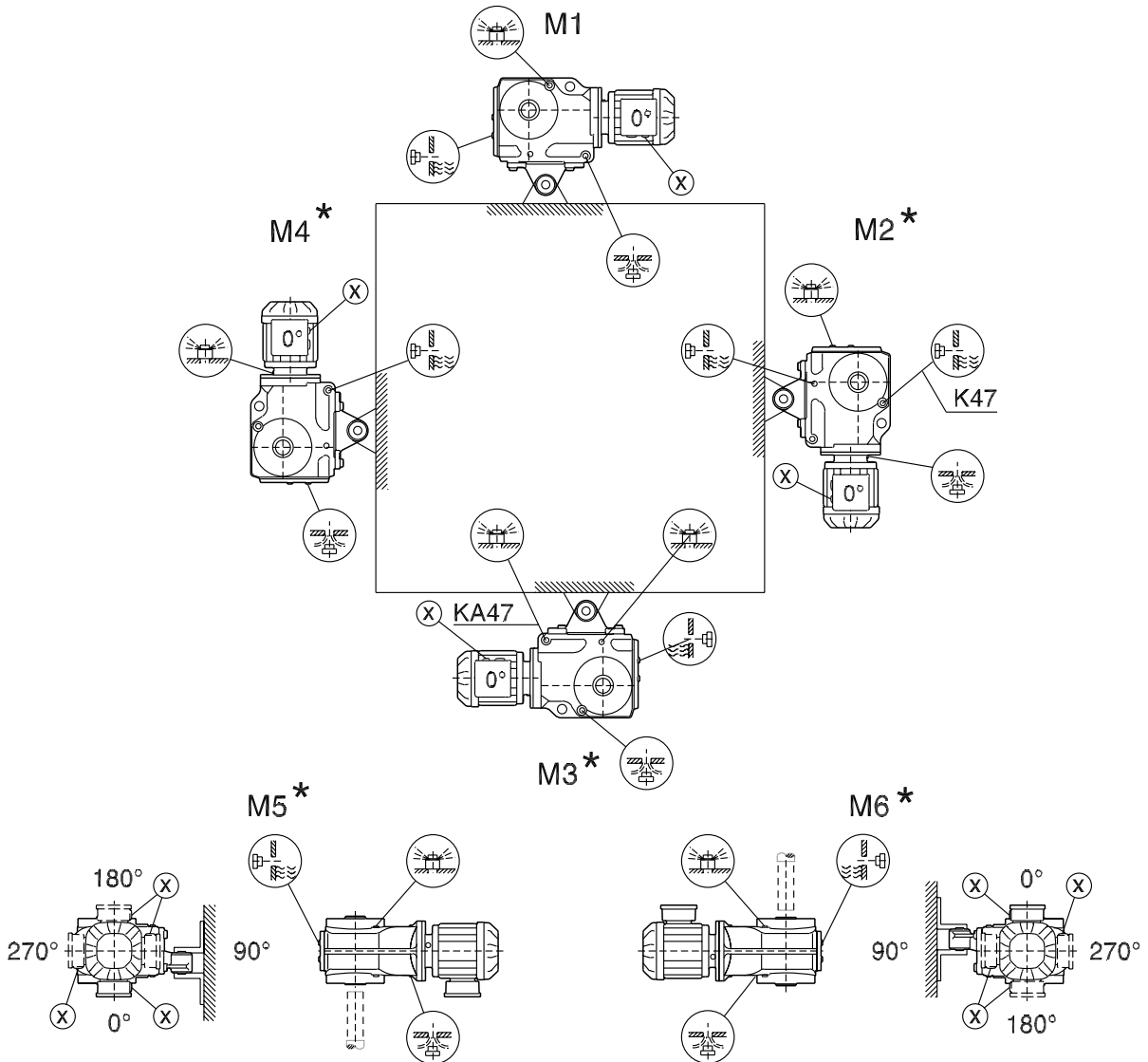
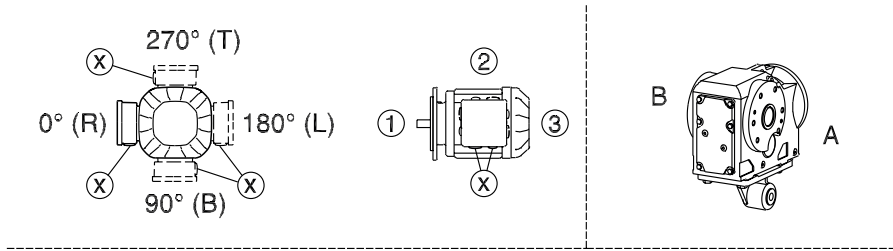

* (→ 60)

2022545/EN – 11/2015

KH167-187

39 026 05 00

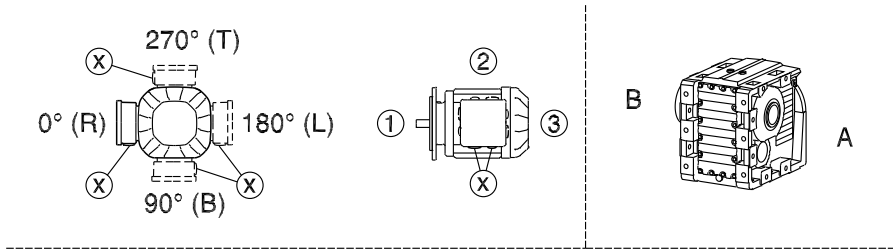

5

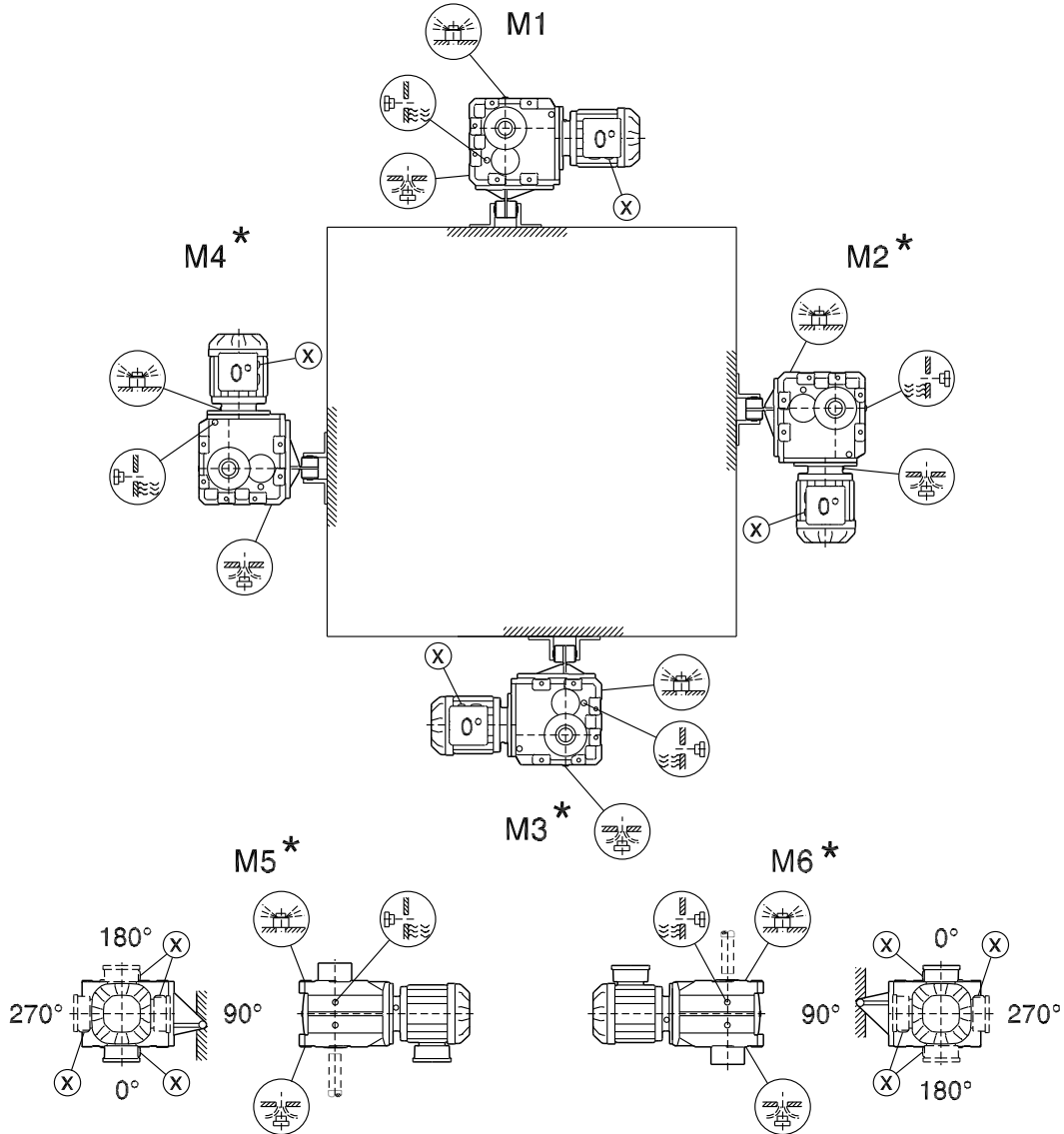

* (→ 60)

20272545/EN – 11/2015

5 Gear unit mounting positions and order information

Mounting position sheets

5.4.4 Mounting positions of helical-worm gearmotors

S37

05 025 04 00

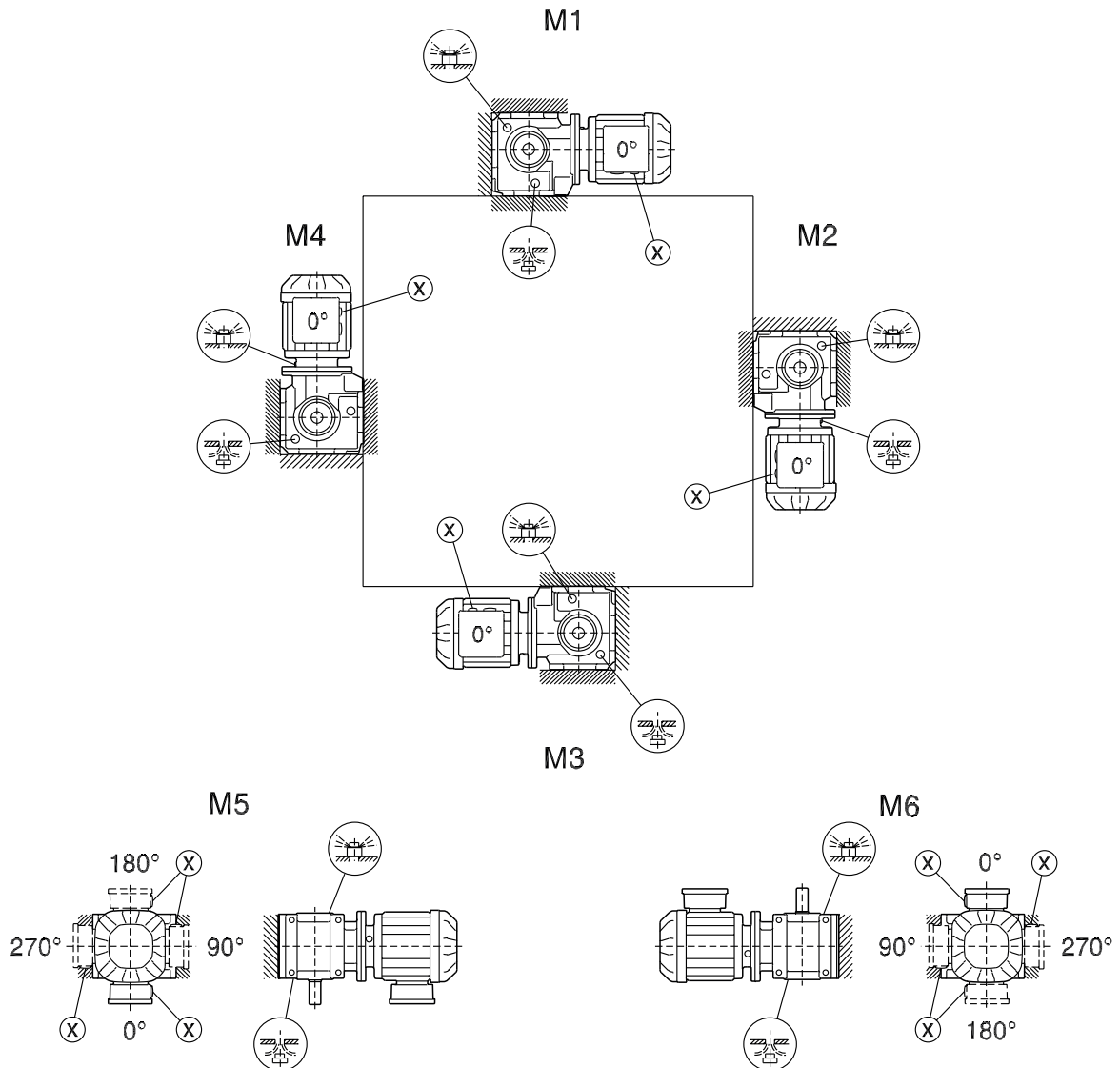
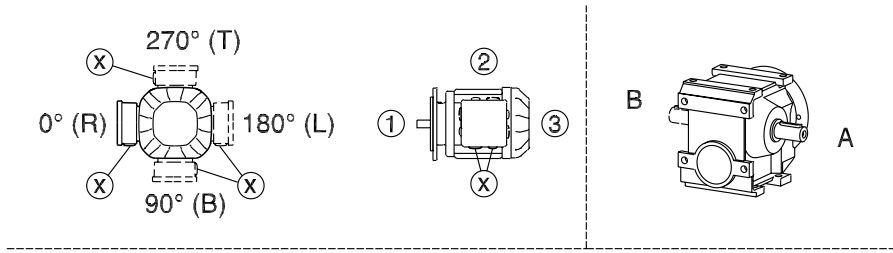

Also refer to the information in chapter "Overhung and axial loads" (→ 46).

20272545/EN – 11/2015

S47-S97

05 026 04 00

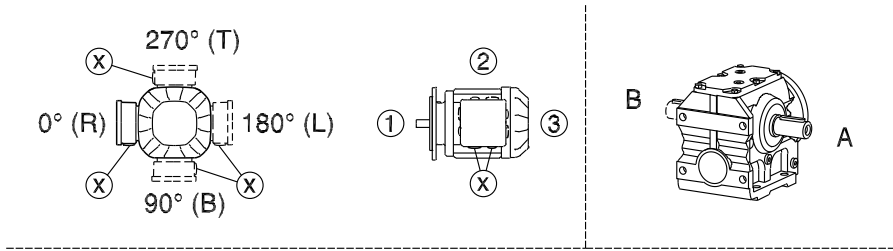

5

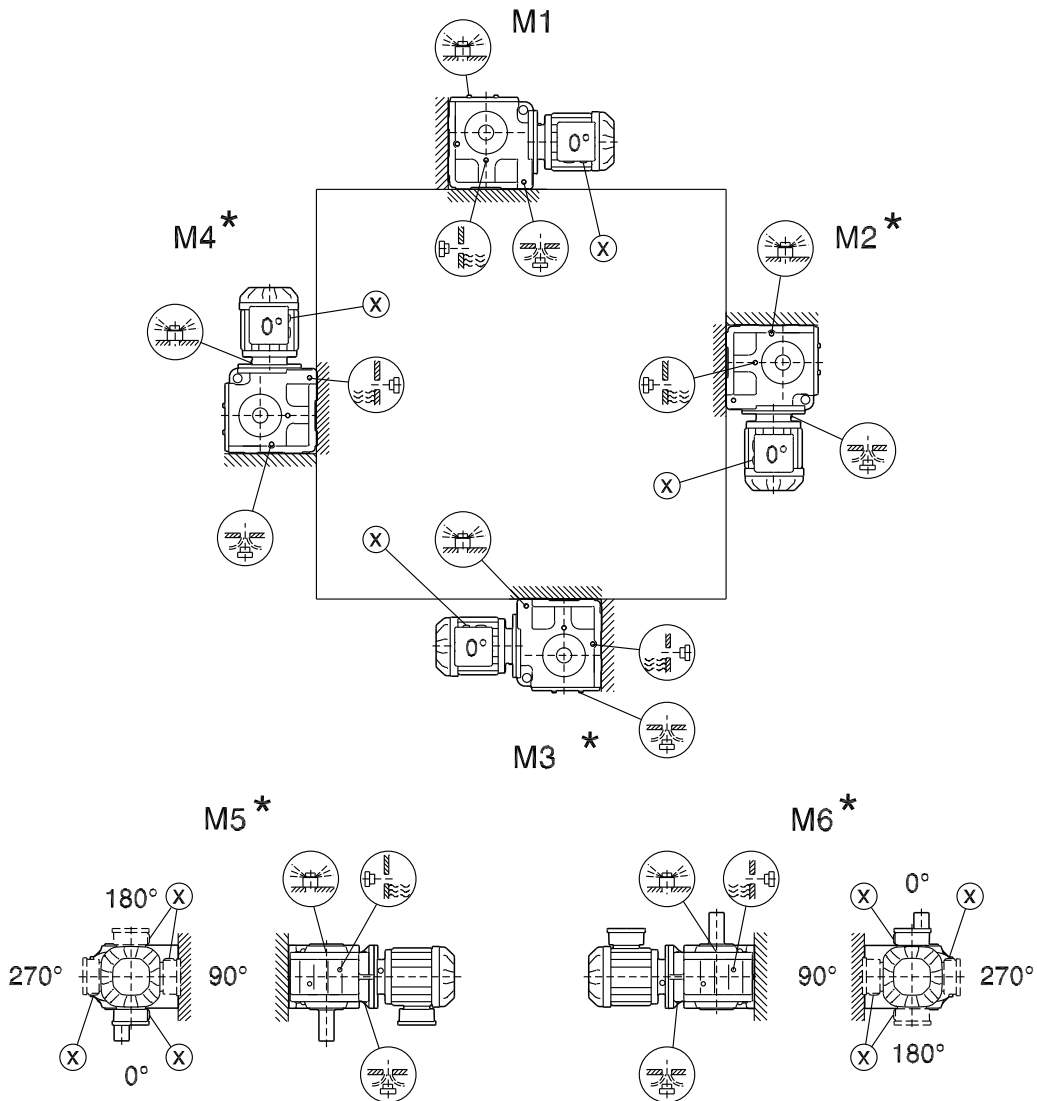

* (→ 60)

Also refer to the information in chapter "Overhung and axial loads" (→ 46).

20272545/EN – 11/2015

5 Gear unit mounting positions and order information

Mounting position sheets

SF/SAF/SHF37

05 027 04 00

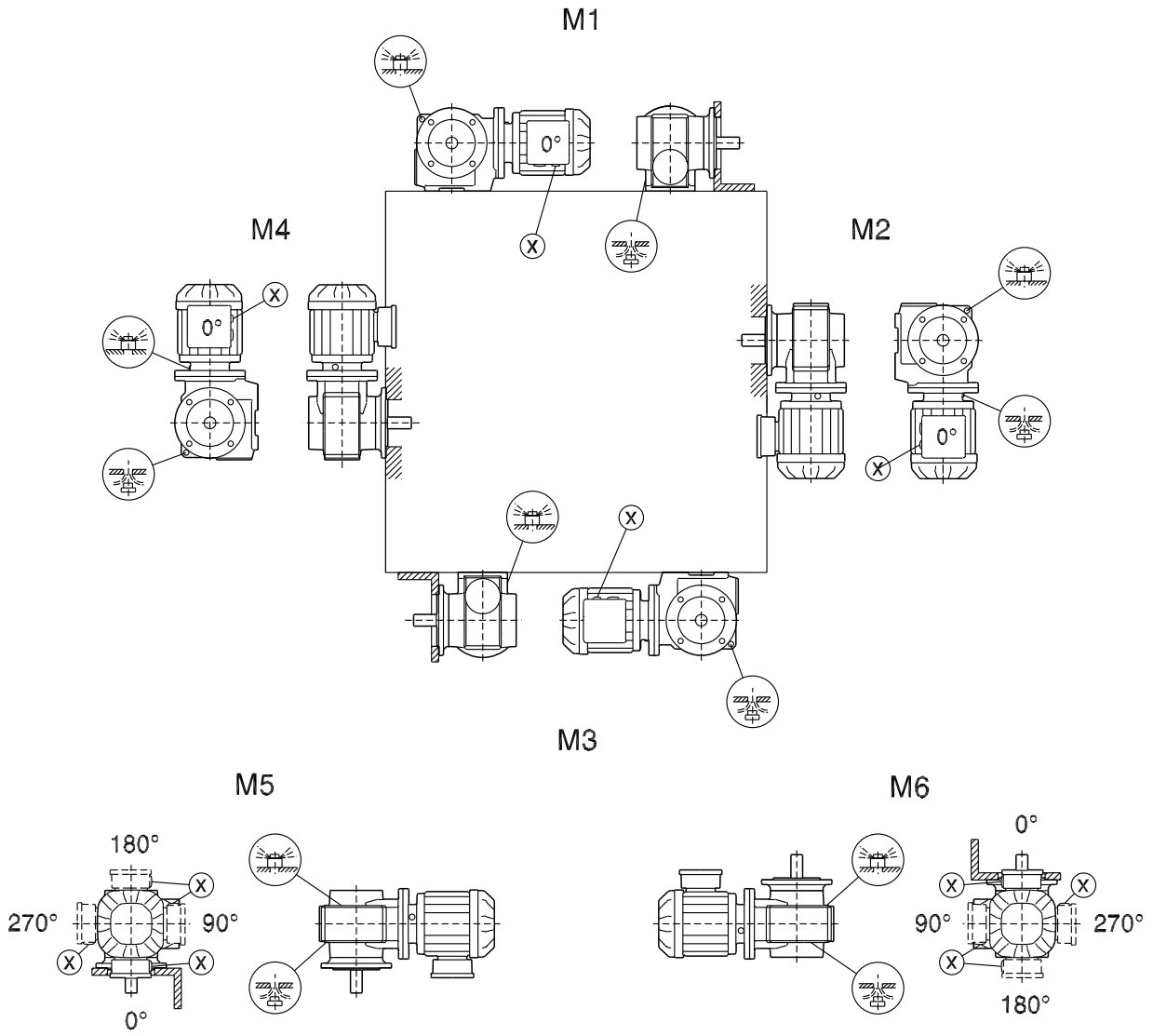
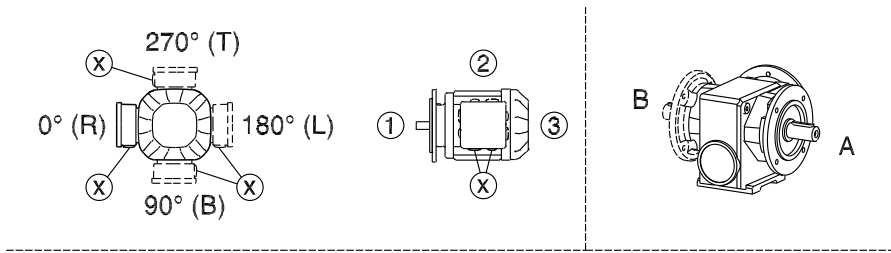

20272545/EN – 11/2015

SF/SAF/SHF/SAZ/SHZ47-97

05 028 04 00

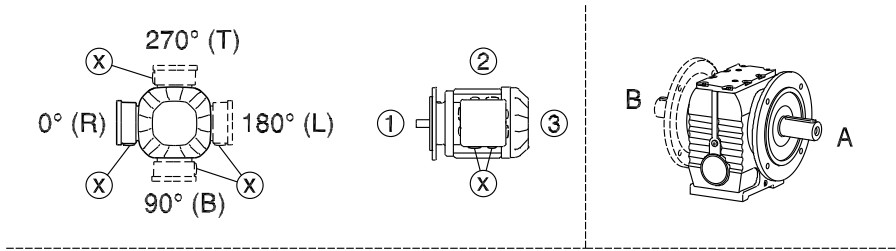

5

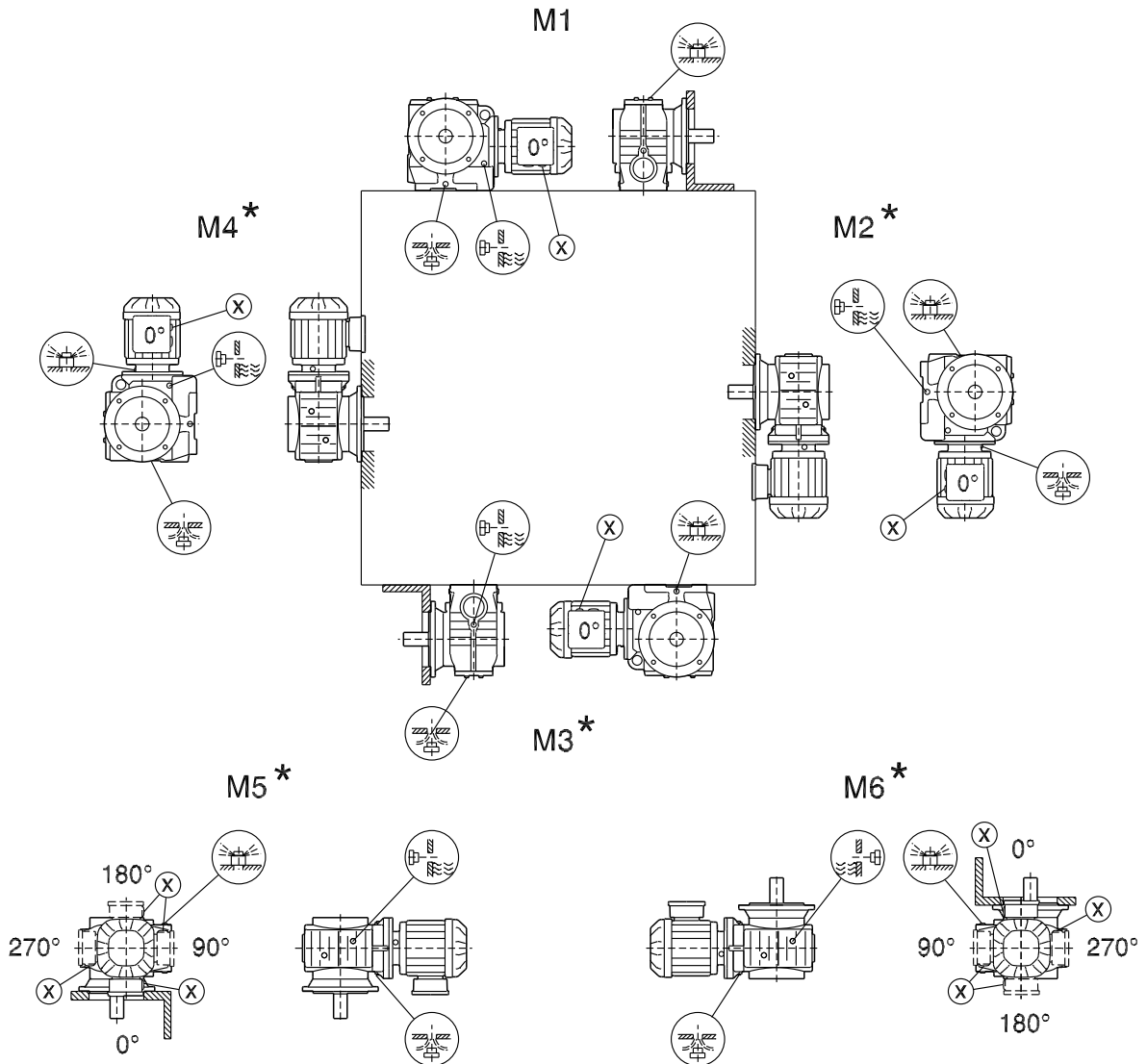

* (→ 60)

20272545/EN – 11/2015

5 Gear unit mounting positions and order information

Mounting position sheets

SA/SH/ST37

28 020 05 00

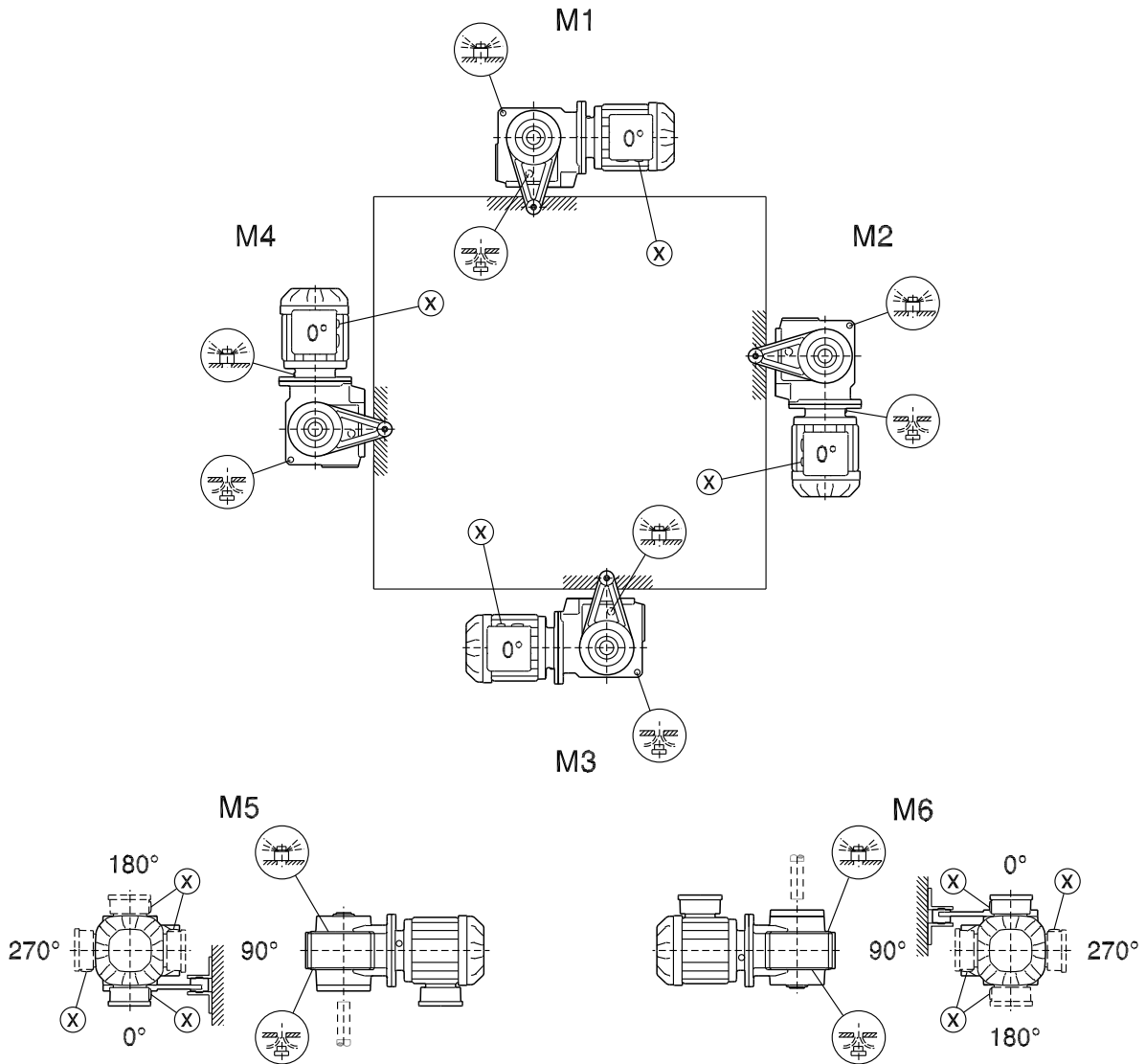
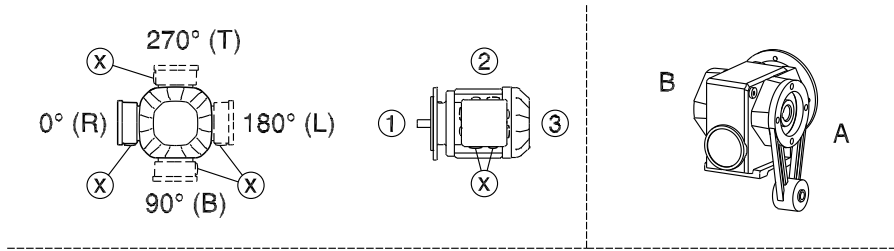

20272545/EN – 11/2015

SA/SH/ST47-97

28 021 04 00

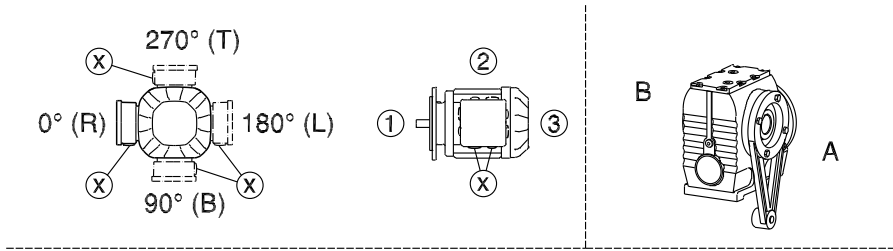

5

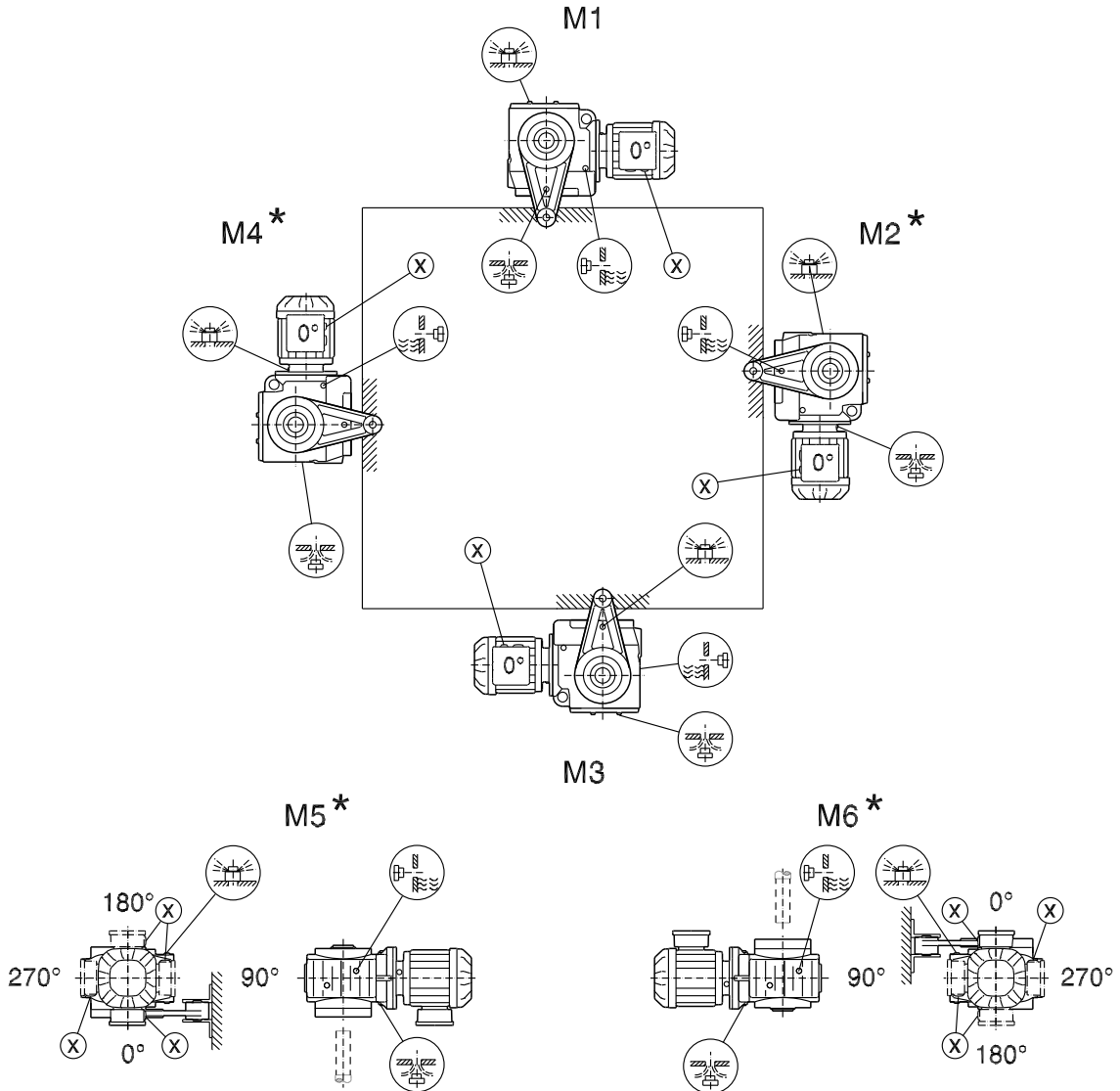

* (→ 60)

20272545/EN – 11/2015

5 Gear unit mounting positions and order information

Mounting position sheets

5.4.5 Mounting positions of SPIROPLAN® gearmotors

W10-30

20 001 02 02

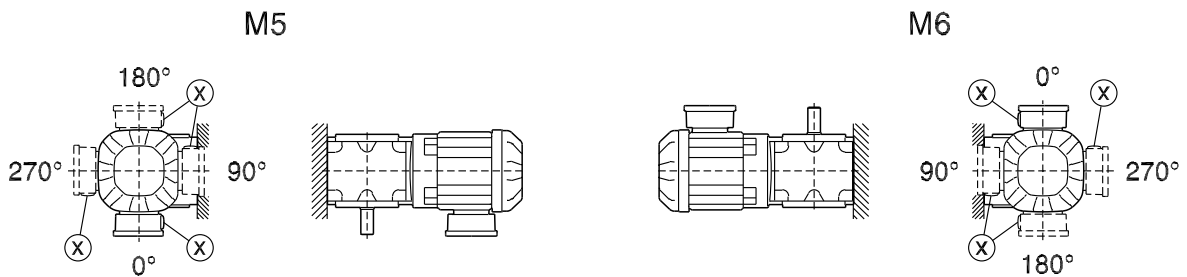
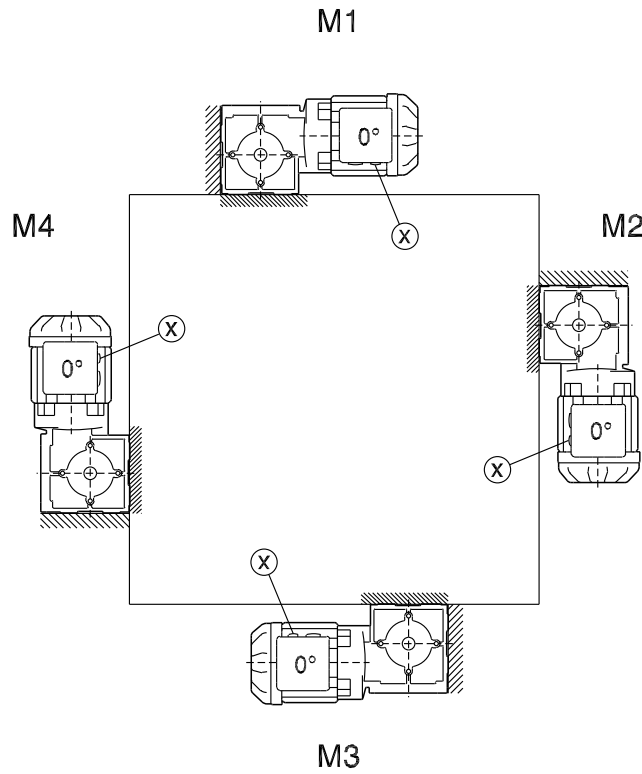
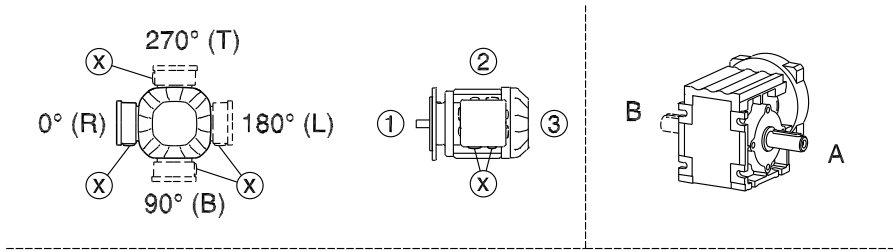

20272545/EN – 11/2015

WF10-30

20 002 02 02

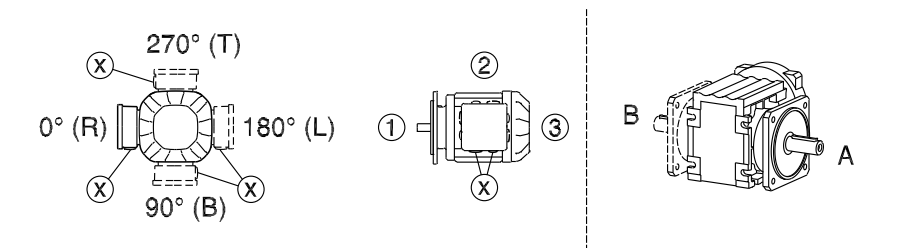

5

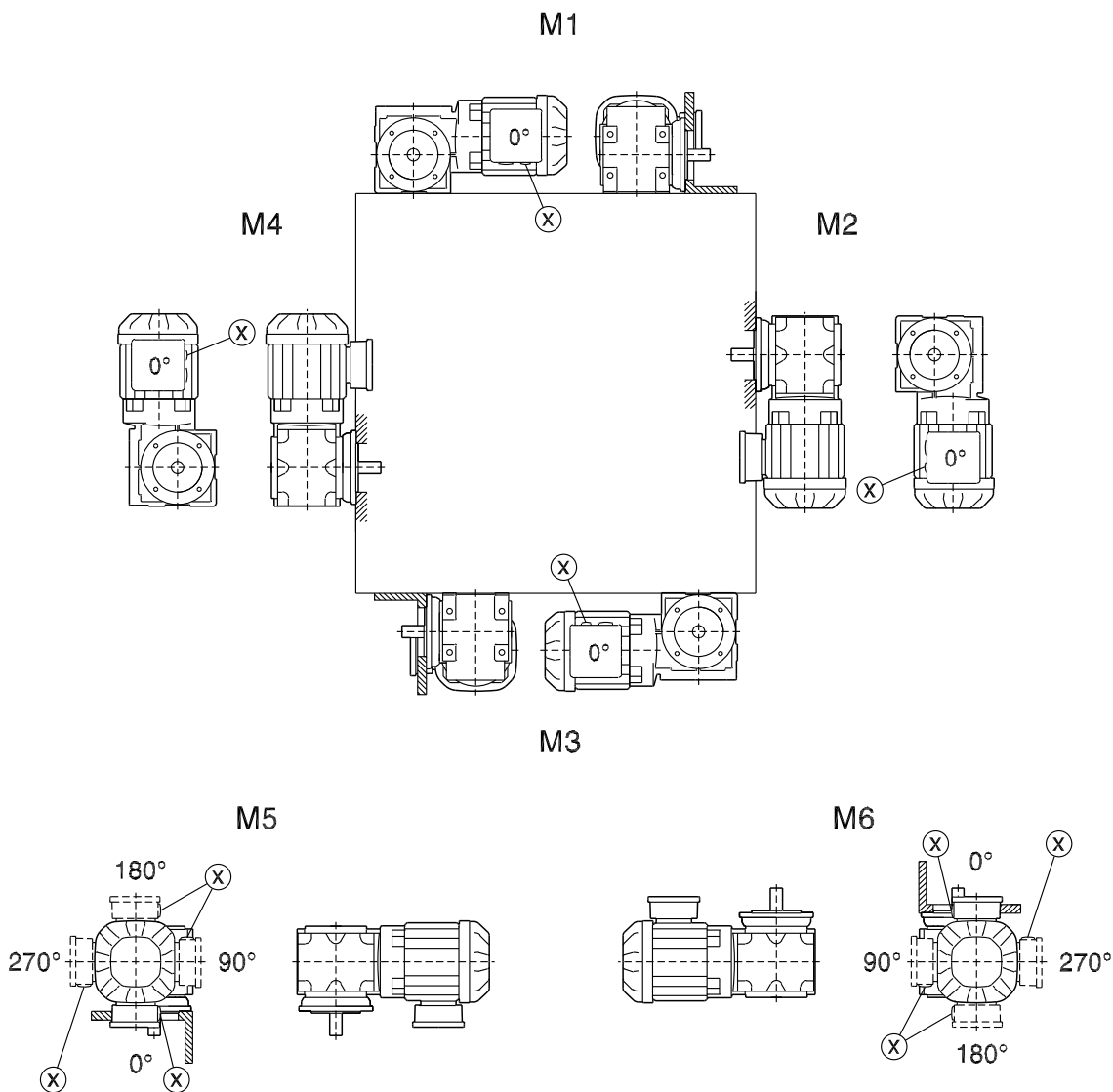

20272545/EN – 11/2015

5 Gear unit mounting positions and order information

Mounting position sheets

WA10-30

20 003 03 02

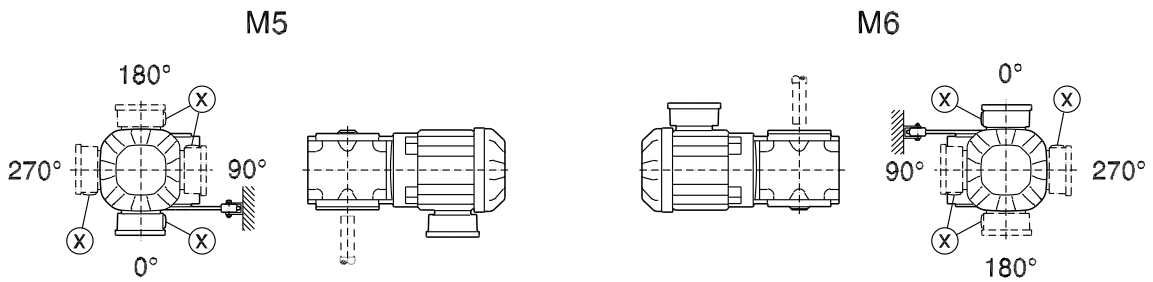
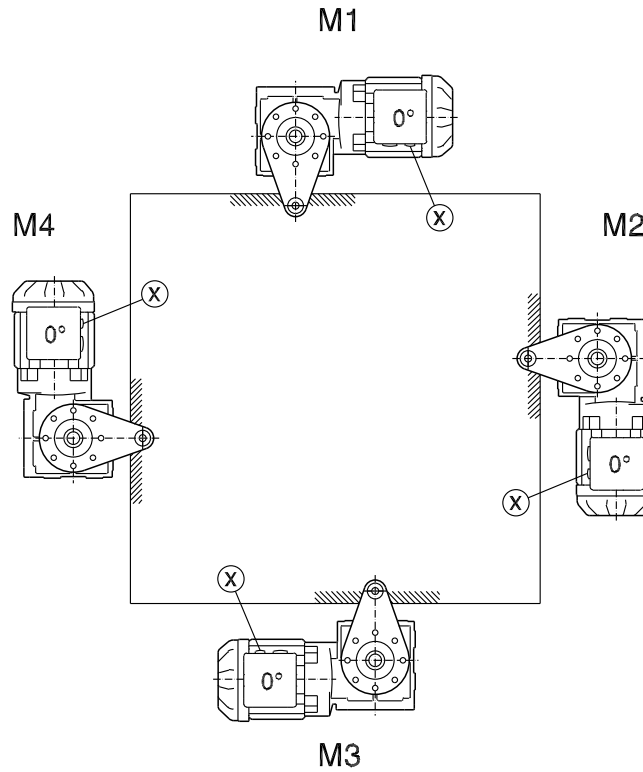
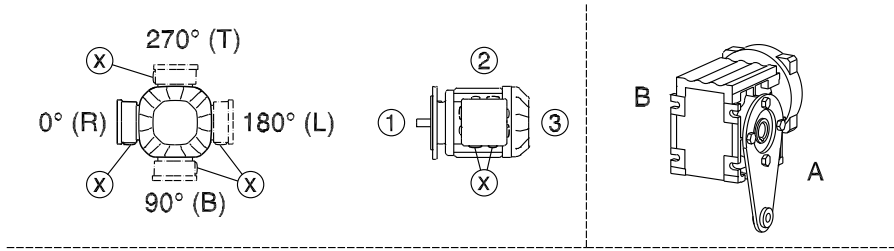

20272545/EN – 11/2015

W/WA..B/WH37B-47B

20 012 02 07

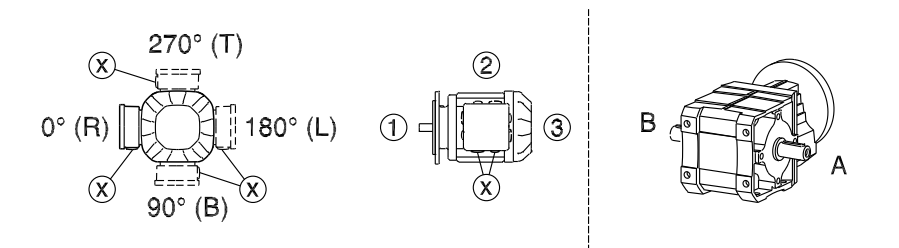

5

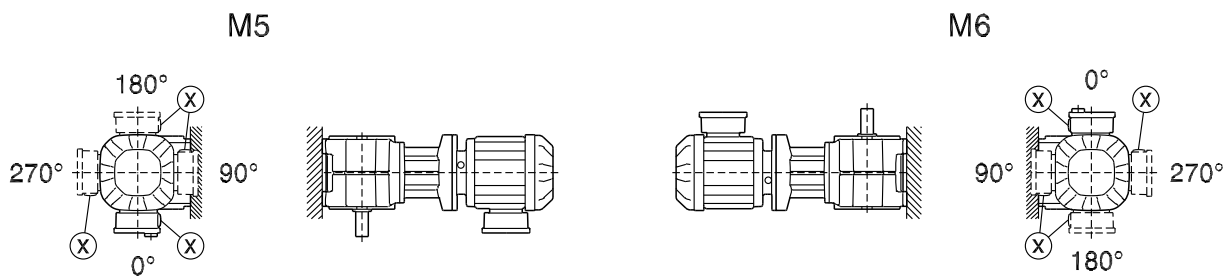
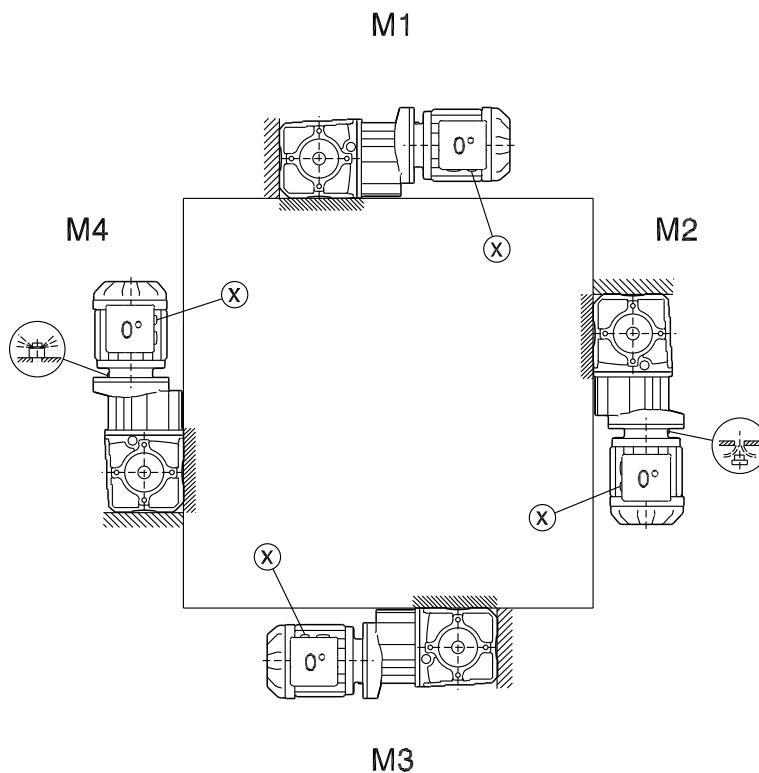

20272545/EN – 11/2015

5 Gear unit mounting positions and order information

Mounting position sheets

WF/WAF/WHF37-47

20 013 02 07

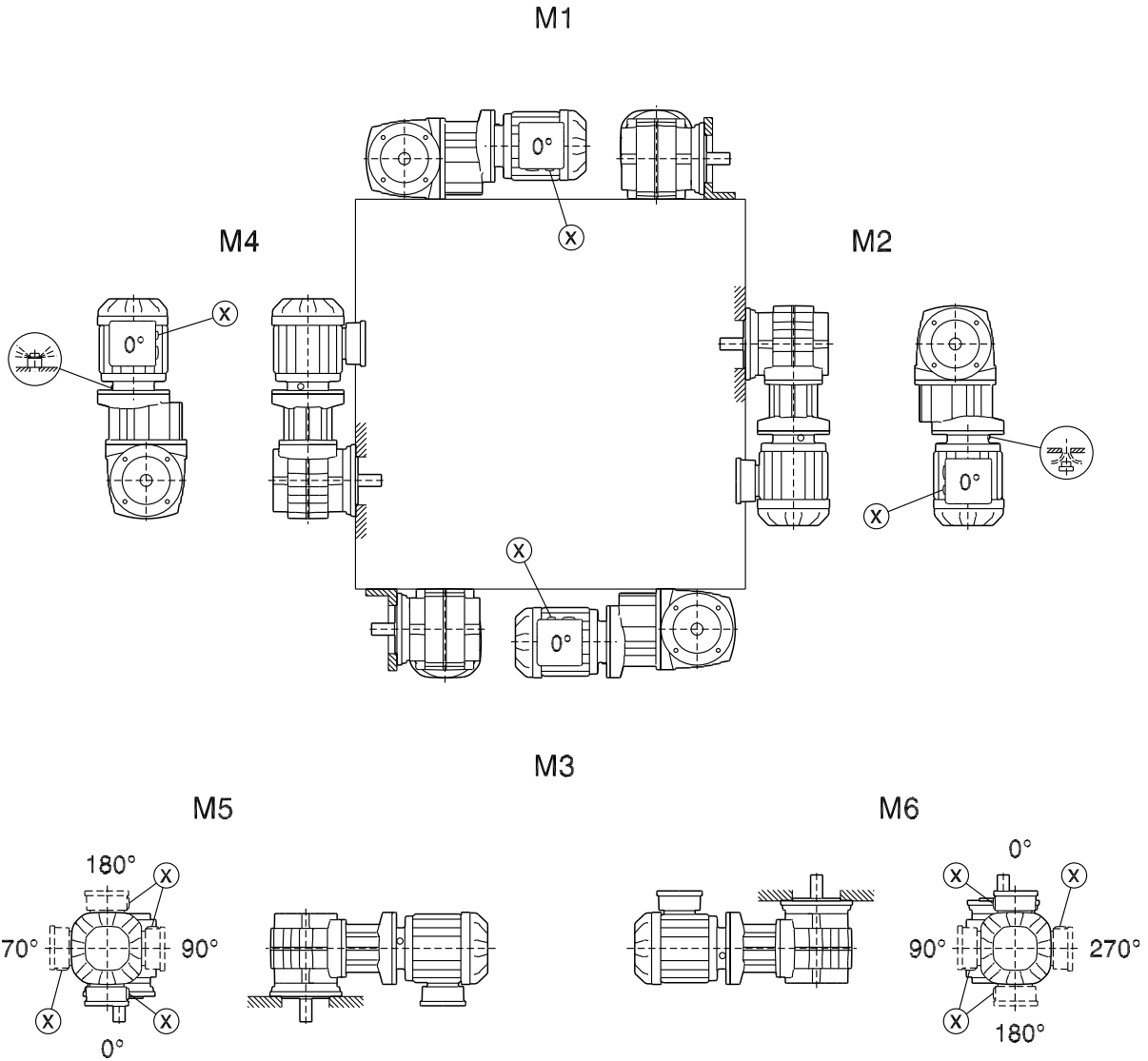
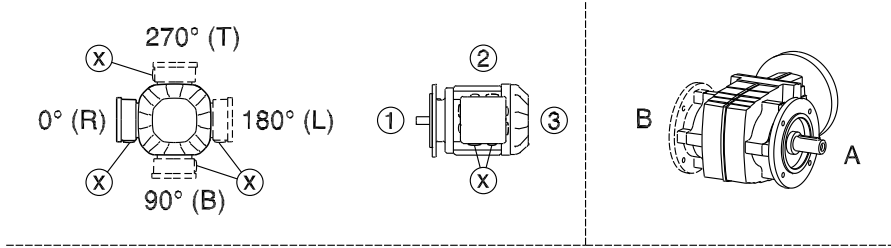

20272545/EN – 11/2015

WA/WH/WT37-47

20 014 02 07

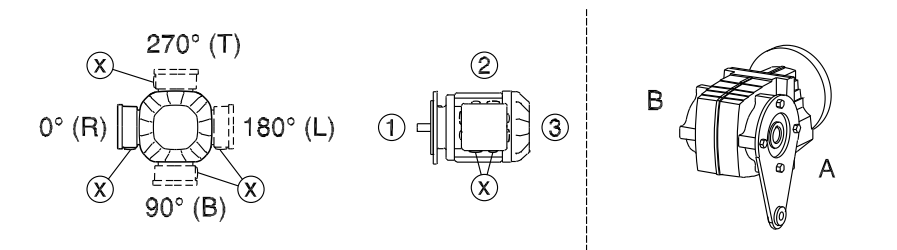

5

M1

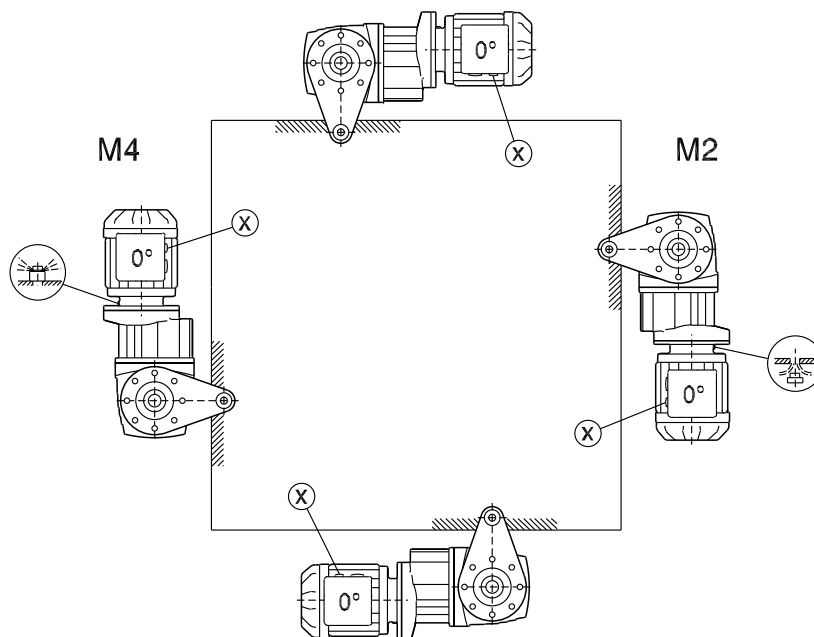

M3

M5

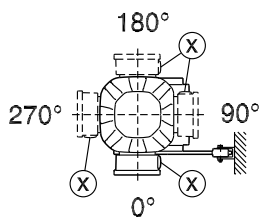

M6

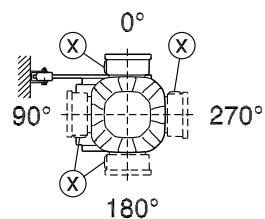

20272545/EN – 11/2015

5 Gear unit mounting positions and order information

Mounting positions of AC motors

5.5 Mounting positions of AC motors

5.5.1 Motor terminal box position and cable entry

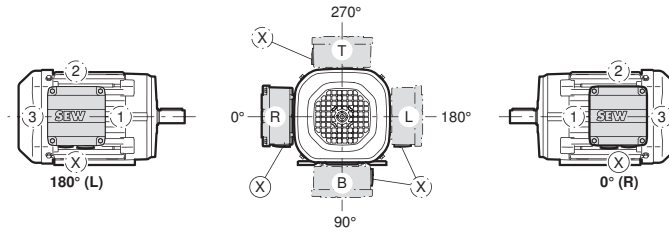

8670476811

5.5.2 Mounting positions

B3 	B6 	B7
B8 	V5 	V6
B5 	V1 	V15
B35 	V3 	V36
B14 	V18 	V17
B34 	V19 	V37
B65 	B75 	B85



18014402484795531

6 Design and operating notes

6.1 Lubricants

6.1.1 Bearing greases

The gear unit rolling bearings are given a factory-fill with the greases listed below. SEW-EURODRIVE recommends re-greasing the rolling bearings with a grease filling at the same time as changing the oil.

	Ambient temperature	Manufacturer	Type
Gear unit rolling bearings	-40 °C to +80 °C	Fuchs	Renolit CX-TOM 15 ¹⁾
	-40 °C to +80 °C	Klüber	Petamo GHY 133 N
	-40 °C to +40 °C	Bremer & Leguil	Cassida Grease GTS 2
	-20 °C to +40 °C	Fuchs	Plantogel 2S

1) Bearing grease based on semi-synthetic base oil

INFORMATION



The following grease quantities are required:

- **For fast-running bearings (gear unit input side):** Fill the cavities between the rolling elements one-third full with grease.
- **For slow-running bearings (gear unit output end):** Fill the cavities between the rolling elements two-thirds full with grease.

6.1.2 Lubricant table

The lubricant table on the following page shows the permitted lubricants for SEW-EURODRIVE gear units.

Key to lubricant table

CLP PG = Polyglycol (W gear units, conforms to USDA-H1)

CLP HC = Synthetic hydrocarbons

E = Ester oil (water hazard class 1 (German regulation – "WKG"))

HCE = Synthetic hydrocarbons + ester oil (USDA - H1 certification)

HLP = Hydraulic oil

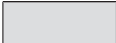
 = Synthetic lubricant (= synthetic roller bearing grease)

1) Helical-worm gear units with PG oil: please consult SEW-EURODRIVE

2) Special lubricant for SPIROPLAN® gear units only

3) Use SEW $f_b \geq 1.2$

4) Pay attention to critical starting behavior at low temperatures.

5) Low-viscosity grease

6 Ambient temperature

7) Bold



Lubricant for the food industry (food grade oil)



Biodegradable oil (lubricant for agriculture, forestry, and fisheries)

Lubricant table

01 751 09 04

	6)		ISO, NLGI	Mobil®	Shell	bp		TEXACO	Castrol	FUCHS	TOTAL
R. K37-187 (HK..) F.	Standard	CLP (CC)	VG 220	Mobilgear 600 XP 220	Shell Omala S2 G 220	BP Energol GR-XP 220	Kiüberoil GEM 1-220 N	Meropa 220	Tribol 1100/220	Renolin CLP 220	Carter EP 220
	+80	CLP PG	VG 220	Mobil Glycoyle 220	Shell Omala S4 GX 220	BP Energol SG-XP 220	Kiüberersynth GH 6-220	Synlube CLP 220	Optiflex A 220	Renolin PG 220	Carter SY 220
	+60	CLP HC	VG 220	Mobil SHC 630	Shell Omala S4 WE 220	BP Energol SG-XP 220	Kiüberersynth GEM 4-220 N	Pinnacle EP 220	Optiflex Synthetic X 220	Renolin Unisyn CLP 220	Carter SH 220
	+40	CLP HC	VG 150	Mobil SHC 629	Shell Omala S4 GX 150	BP Energol SG-XP 150	Kiüberoil GEM 4-150 N	Pinnacle EP 150	Optiflex Synthetic X 150	Renolin Unisyn CLP 150	Carter SH 150
K..19 - K..49	+25	CLP (CC)	VG 150	Mobilgear 600 XP 150	Shell Omala S2 G 150	BP Energol GR-XP 150	Kiüberoil GEM 1-150 N	Meropa 150	Tribol 1100/150	Renolin CLP 150	Carter EP 150
	+20	CLP HC	VG 68	Mobil SHC 626	Shell Omala S4 GX 68	BP Energol GR-XP 150	Kiüber-Summit HySyn FG-32	Cetus PAO 46		Renolin Unisyn CLP 68	
	+0	CLP HC	VG 32	Mobil SHC 624	Shell Omala S4 GX 68	BP Energol GR-XP 150	Kiüberersynth GH 6-460	Cetus PAO 46	Optiflex HY 32	Renolin Unisyn OL 32	Dacnis SH 32
	Standard	CLP PG	VG 460			BP Energol GR-XP 680	Kiüberersynth UH1 6-460				
S..(HS..)	+60	H1 PG	VG 460			BP Energol GR-XP 680	Kiüberersynth UH1 6-460				
	+40	CLP (CC)	VG 680	Mobilgear 600 XP 680	Shell Omala S2 G 680	BP Energol GR-XP 680	Kiüberoil GEM 1-680 N	Meropa 680	Tribol 1100/680	Renolin SEW 680	Carter EP 680
	+30	CLP PG	VG 680	Mobil Glycoyle 680	Shell Omala S4 WE 680	BP Energol SG-XP 680	Kiüberersynth GH 6-680	Synlube CLP 680	Optiflex A 680	Renolin PG 680	
	+20	CLP HC	VG 460	Mobil SHC 634	Shell Omala S4 GX 460	BP Energol SG-XP 680	Kiüberersynth GEM 4-460 N	Pinnacle EP 460	Optiflex Synthetic X 460	Renolin Unisyn CLP 460	Carter SH 460
R.. K37-187 (HK..) F.. S..(HS..)	+30	CLP HC	VG 150	Mobil SHC 629	Shell Omala S4 GX 150	BP Energol SG-XP 150	Kiüberersynth GEM 4-150 N	Pinnacle EP 150	Optiflex Synthetic X 150	Renolin Unisyn CLP 150	Carter SH 150
	+10	CLP (CC)	VG 150	Mobilgear 600 XP 150	Shell Omala S2 G 150	BP Energol GR-XP 150	Kiüberoil GEM 1-150 N	Meropa 150	Tribol 1100/150	Renolin CLP 150	Carter EP 150
	+40	CLP PG	VG 220	Mobil Glycoyle 220	Shell Omala S4 WE 220	BP Energol SG-XP 220	Kiüberersynth GH 6-220	Synlube CLP 220	Optiflex A 220	Renolin PG 220	Carter SY 220
	+20	CLP HC	VG 68	Mobil SHC 626	Shell Omala S4 GX 68	BP Energol GR-XP 220	Kiüber-Summit HySyn FG-32	Cetus PAO 46	Alphasyn T32	Renolin Unisyn CLP 68	Dacnis SH 32
W..(HW..)	Standard	CLP HC	VG 32	Mobil SHC 624	Shell Omala S4 GX 68	BP Energol GR-XP 220	Kiüber-Summit HySyn FG-32	Cetus PAO 46		Renolin Unisyn OL 32	
	+40	CLP HC	VG 460			BP Energol GR-XP 220	Kiüberoil 4UH1-460 N		Optiflex GT 460	Cassida Fluid GL 460	
	+10	CLPHC NSF H1	VG 460			BP Energol GR-XP 220	Kiüberoil 4UH1-220 N		Optiflex GT 220	Cassida Fluid GL 220	
	+30	CLP PG	VG 220			BP Energol SG-XP 220	Kiüberoil 4UH1-68 N		Optiflex HY 68	Cassida Fluid HF 68	
PS.F..	+60	E	VG 460			BP Energol GR-XP 220	Kiüberbio CA2-460			Plantogear 460 S	
	+40	SEW PG	VG 460			BP Energol GR-XP 220	Kiüber SEW HT-460-5				
	+10	API GL5	SAE 75W90 (-VG 100)	Mobil Synth Gear Oil 75 W90		BP Energol GR-XP 220	Kiüberersynth UH1 6-460				
	+60	H1 PG	VG 460			BP Energol GR-XP 220	Kiüberersynth UH1 6-460				
PS.C..	Standard	CLP PG	VG 220			BP Energol GR-XP 220	Kiüberoil GH 6-220				
	+60	H1 PG	VG 460			BP Energol GR-XP 220	Kiüberersynth UH1 6-460				
	+40	CLP HC	VG 32	Mobil SHC 624		BP Energol GR-XP 220	Kiüberersynth UH1 6-460				
	+20	CLP (CC)	VG 220	Mobilgear 600 XP 220		BP Energol GR-XP 220	Kiüberersynth UH1 14-151				
BS.F..	Standard	DIN 51 818	NLGI 00	Mobilux EP 004		BP Energol GR-XP 220	Kiüberersynth UH1 14-151				
	+40	DIN 51 818	NLGI 1			BP Energol GR-XP 220	Kiüberersynth UH1 6-460				
	+20	CLP HC	VG 32	Mobil SHC 624		BP Energol GR-XP 220	Kiüberersynth UH1 6-460				
	Standard	CLP PG	VG 220			BP Energol GR-XP 220	Kiüberersynth UH1 6-460				

54043198373448075

INFORMATION



This lubricant recommendation in no way represents a guarantee as to the quality of the lubricant delivered by each respective supplier. Each lubricant manufacturer is responsible for the quality of their product. Thus the lubricant table is not binding. It may be necessary to contact SEW-EURODRIVE.

6.1.3 Lubricant fill quantities

INFORMATION



The specified fill quantities are only given as a **guideline**. The precise values vary depending on the number of stages and gear ratio. When filling, it is essential to check the **oil level plug since it indicates the precise oil volume**.

The following tables show guide values for lubricant fill quantities in relation to the mounting position M1 – M6.

Helical (R) gear units

R..., R..F

Gear unit	Fill quantity in liters						
	M1 ¹⁾	M2	M3	M4	M5	M6	
R07	0.12	0.20					
R17	0.25	0.55	0.35	0.55	0.35	0.40	
R27	0.25/0.40	0.70	0.50	0.70	0.50		
R37	0.30/0.95	0.85	0.95	1.05	0.75	0.95	
R47	0.70/1.50	1.60	1.50	1.65	1.50		
R57	0.80/1.70	1.90	1.70	2.10	1.70		
R67	1.10/2.30	2.40	2.80	2.90	1.80	2.00	
R77	1.20/3.00	3.30	3.60	3.80	2.50	3.40	
R87	2.30/6.0	6.4	7.2		6.3	6.5	
R97	4.60/9.8	11.7		13.4	11.3	11.7	
R107	6.0/13.7	16.3	16.9	19.2	13.2	15.9	
R137	10.0/25.0	28.0	29.5	31.5	25.0		
R147	15.4/40.0	46.5	48.0	52.0	39.5	41.0	
R167	27.0/70.0	82.0	78.0	88.0	66.0	69.0	

1) The larger gear unit of multi-stage gear units must be filled with the larger oil quantity.

RF..., RZ..

Gear unit	Fill quantity in liters						
	M1 ¹⁾	M2	M3	M4	M5	M6	
RF07	0.12	0.20					
RF17	0.25	0.55	0.35	0.55	0.35	0.40	
RF27	0.25/0.40	0.70	0.50	0.70	0.50		
RF37	0.35/0.95	0.90	0.95	1.05	0.75	0.95	
RF47	0.65/1.50	1.60	1.50	1.65	1.50		
RF57	0.80/1.70	1.80	1.70	2.00	1.70		
RF67	1.20/2.50	2.50	2.70	2.80	1.90	2.10	
RF77	1.20/2.60	3.10	3.30	3.60	2.40	3.00	
RF87	2.40/6.0	6.4	7.1	7.2	6.3	6.4	
RF97	5.1/10.2	11.9	11.2	14.0	11.2	11.8	
RF107	6.3/14.9	15.9	17.0	19.2	13.1	15.9	
RF137	9.5/25.0	27.0	29.0	32.5	25.0		
RF147	16.4/42.0	47.0	48.0	52.0	42.0	42.0	
RF167	26.0/70.0	82.0	78.0	88.0	65.0	71.0	

1) The larger gear unit of multi-stage gear units must be filled with the larger oil quantity.

RX..

Gear unit	Fill quantity in liters					
	M1	M2	M3	M4	M5	M6
RX57	0.60	0.80	1.30		0.90	
RX67	0.80		1.70	1.90	1.10	
RX77	1.10	1.50	2.60	2.70	1.60	
RX87	1.70	2.50	4.80		2.90	
RX97	2.10	3.40	7.4	7.0	4.80	
RX107	3.90	5.6	11.6	11.9	7.7	

RXF..

Gear unit	Fill quantity in liters					
	M1	M2	M3	M4	M5	M6
RXF57	0.50	0.80	1.10		0.70	
RXF67	0.70	0.80	1.50	1.40	1.00	
RXF77	0.90	1.30	2.40	2.00	1.60	
RXF87	1.60	1.95	4.90	3.95	2.90	
RXF97	2.10	3.70	7.1	6.3	4.80	
RXF107	3.10	5.7	11.2	9.3	7.2	

Parallel shaft helical (F) gear units

F.., FA..B, FH..B, FV..B

Gear units	Fill quantity in liters					
	M1	M2	M3	M4	M5	M6
F..27	0.60	0.80	0.65	0.70	0.60	
F..37	0.95	1.25	0.70	1.25	1.00	1.10
F..47	1.50	1.80	1.10	1.90	1.50	1.70
F..57	2.60	3.50	2.10	3.50	2.80	2.90
F..67	2.70	3.80	1.90	3.80	2.90	3.20
F..77	5.9	7.3	4.30	8.0	6.0	6.3
F..87	10.8	13.0	7.7	13.8	10.8	11.0
F..97	18.5	22.5	12.6	25.2	18.5	20.0
F..107	24.5	32.0	19.5	37.5	27.0	
F..127	40.5	54.5	34.0	61.0	46.3	47.0
F..157	69.0	104.0	63.0	105.0	86.0	78.0

FF..

Gear units	Fill quantity in liters					
	M1	M2	M3	M4	M5	M6
FF27	0.60	0.80	0.65	0.70	0.60	
FF37	1.00	1.25	0.70	1.30	1.00	
FF47	1.60	1.85	1.10	1.90	1.50	1.70
FF57	2.80	3.50	2.10	3.70	2.90	3.00
FF67	2.70	3.80	1.90	3.80	2.90	3.20
FF77	5.9	7.3	4.30	8.1	6.0	6.3
FF87	10.8	13.2	7.8	14.1	11.0	11.2
FF97	19.0	22.5	12.6	25.6	18.9	20.5
FF107	25.5	32.0	19.5	38.5	27.5	28.0
FF127	41.5	55.5	34.0	63.0	46.3	49.0
FF157	72.0	105.0	64.0	106.0	87.0	79.0

FA.., FH.., FV.., FAF.., FAZ.., FHF.., FZ.., FHZ.., FVF.., FVZ.., FT..

Gear units	Fill quantity in liters					
	M1	M2	M3	M4	M5	M6
F..27	0.60	0.80	0.65	0.70	0.60	
F..37	0.95	1.25	0.70	1.25	1.00	1.10
F..47	1.50	1.80	1.10	1.90	1.50	1.70
F..57	2.70	3.50	2.10	3.40	2.90	3.00
F..67	2.70	3.80	1.90	3.80	2.90	3.20
F..77	5.9	7.3	4.30	8.0	6.0	6.3
F..87	10.8	13.0	7.7	13.8	10.8	11.0
F..97	18.5	22.5	12.6	25.2	18.5	20.0
F..107	24.5	32.0	19.5	37.5	27.0	
F..127	39.0	54.5	34.0	61.0	45.0	46.5
F..157	68.0	103.0	62.0	104.0	85.0	79.5

Helical-bevel (K) gear units

INFORMATION



All K..19 and K..29 gear units have a universal mounting position, which means that K..19 and K..29 gear units of the same design are filled with the same oil quantity independent of the mounting position. An exception to this is the M4 mounting position.

K.., KA..B, KH..B, KV..B

Gear unit	Fill quantity in liters					
	M1	M2	M3	M4	M5	M6
K..19	0.40			0.45	0.40	
K..29	0.70			0.85	0.70	
K..39	0.90	1.70	1.55	1.9	1.55	1.30
K..49	1.70	3.40	2.80	4.20	3.15	2.80
K..37	0.50	1.00		1.25	0.95	
K..47	0.80	1.30	1.50	2.00	1.60	
K..57	1.10	2.20		2.80	2.30	2.10
K..67	1.10	2.40	2.60	3.45	2.60	
K..77	2.20	4.10	4.40	5.80	4.20	4.40
K..87	3.70	8.0	8.70	10.90	8.0	
K..97	7.0	14.0	15.70	20.0	15.70	15.50
K..107	10.0	21.0	25.50	33.50	24.0	
K..127	21.0	41.50	44.0	54.0	40.0	41.0
K..157	31.0	65.0	68.0	90.0	62.0	63.0
K..167	33.0	97.0	109.0	127.0	89.0	86.0
K..187	53.0	156.0	174.0	207.0	150.0	147.0

KF..

Gear unit	Fill quantity in liters					
	M1	M2	M3	M4	M5	M6
KF19	0.40			0.45	0.40	
KF29	0.70			0.85	0.70	
KF39	0.90	1.70	1.55	1.9	1.55	1.30
KF49	1.70	3.40	2.80	4.20	3.15	2.80
KF37	0.50	1.10		1.50	1.00	
KF47	0.80	1.30	1.70	2.20	1.60	
KF57	1.20	2.20	2.40	3.15	2.50	2.30
KF67	1.10	2.40	2.80	3.70	2.70	
KF77	2.10	4.10	4.40	5.90	4.50	

Gear unit	Fill quantity in liters					
	M1	M2	M3	M4	M5	M6
KF87	3.70	8.20	9.0	11.90	8.40	
KF97	7.0	14.70	17.30	21.50	15.70	16.50
KF107	10.0	21.80	25.80	35.10	25.20	
KF127	21.0	41.50	46.0	55.0	41.0	
KF157	31.0	66.0	69.0	92.0	62.0	63.0

KA.., KH.., KV.., KAF.., KHF.., KVF.., KZ.., KAZ.., KHZ.., KVZ.., KT..

Gear unit	Fill quantity in liters					
	M1	M2	M3	M4	M5	M6
K..19	0.40			0.45	0.40	
K..29	0.70			0.85	0.70	
K..39	0.90	1.70	1.55	1.9	1.55	1.30
K..49	1.70	3.40	2.80	4.20	3.15	2.80
K..37	0.50	1.00		1.40	1.00	
K..47	0.80	1.30	1.60	2.15	1.60	
K..57	1.20	2.20	2.40	3.15	2.70	2.40
K..67	1.10	2.40	2.70	3.70	2.60	
K..77	2.10	4.10	4.60	5.90	4.40	
K..87	3.70	8.20	8.80	11.10	8.0	
K..97	7.0	14.70	15.70	20.0	15.70	
K..107	10.0	20.50	24.0	32.40	24.0	
K..127	21.0	41.50	43.0	52.0	40.0	
K..157	31.0	65.0	68.0	90.0	62.0	63.0
K..167	33.0	97.0	109.0	127.0	89.0	86.0
K..187	53.0	156.0	174.0	207.0	150.0	147.0

Helical-worm (S) gear units

S..

Gear unit	Fill quantity in liters					
	M1	M2	M3 ¹⁾	M4	M5	M6
S37	0.25	0.40	0.50	0.55	0.40	
S47	0.35	0.80	0.70/0.90	1.00	0.80	
S57	0.50	1.20	1.00/1.20	1.45	1.30	
S67	1.00	2.00	2.20/3.10	3.10	2.60	2.60
S77	1.90	4.20	3.70/5.4	5.9	4.40	
S87	3.30	8.1	6.9/10.4	11.3	8.4	
S97	6.8	15.0	13.4/18.0	21.8	17.0	

1) The larger gear unit of multi-stage gear units must be filled with the larger oil quantity.

SF..

Gear unit	Fill quantity in liters					
	M1	M2	M3 ¹⁾	M4	M5	M6
SF37	0.25	0.40	0.50	0.55	0.40	
SF47	0.40	0.90	0.90/1.05	1.05	1.00	
SF57	0.50	1.20	1.00/1.50	1.55	1.40	
SF67	1.00	2.20	2.30/3.00	3.20	2.70	
SF77	1.90	4.10	3.90/5.8	6.5	4.90	
SF87	3.80	8.0	7.1/10.1	12.0	9.1	
SF97	7.4	15.0	13.8/18.8	22.6	18.0	

1) The larger gear unit of multi-stage gear units must be filled with the larger oil quantity.

SA.., SH.., SAF.., SHZ.., SAZ.., SHF.., ST..

Gear unit	Fill quantity in liters					
	M1	M2	M3 ¹⁾	M4	M5	M6
S..37	0.25	0.40	0.50		0.40	
S..47	0.40	0.80	0.70/0.90	1.00	0.80	
S..57	0.50	1.10	1.00/1.50	1.50	1.20	
S..67	1.00	2.00	1.80/2.60	2.90	2.50	
S..77	1.80	3.90	3.60/5.0	5.8	4.50	
S..87	3.80	7.4	6.0/8.7	10.8	8.0	
S..97	7.0	14.0	11.4/16.0	20.5	15.7	

1) The larger gear unit of multi-stage gear units must be filled with the larger oil quantity.

SPIROPLAN® (W) gear units



INFORMATION

SPIROPLAN® gear units W..10 to W..30 have a universal mounting position, which means that gear units of the same design are filled with the same oil quantity independent of the mounting position.

The oil fill quantity of SPIROPLAN® gear units W..37 and W..47 in mounting position M4 is different from that of the other mounting positions.

W.., WA..B, WH..B

Gear unit	Fill quantity in liters					
	M1	M2	M3	M4	M5	M6
W..10	0.16					
W..20	0.24					
W..30	0.40					
W..37	0.50		0.70		0.50	
W..47	0.90		1.40		0.90	

WF..

Gear unit	Fill quantity in liters					
	M1	M2	M3	M4	M5	M6
WF10	0.16					
WF20	0.24					
WF30	0.40					
WF37	0.50		0.70		0.50	
WF47	0.90		1.55		0.90	

WA.., WAF.., WH.., WT.., WHF..

Gear unit	Fill quantity in liters					
	M1	M2	M3	M4	M5	M6
W..10	0.16					
W..20	0.24					
W..30	0.40					
W..37	0.50		0.70		0.50	
W..47	0.80		1.40		0.80	

6.2 Gear unit venting

INFORMATION



The function of breather valves can be impaired by dirt and dust in the environment. If necessary, contact SEW-EURODRIVE to discuss alternative venting systems.

6.3 Reduced backlash gear unit design /R

Helical, parallel-shaft helical and helical-bevel gear units with reduced backlash are available as of gear unit size 37. The rotational clearance of these gear units is considerably less than that of the standard designs so that positioning tasks can be solved with great precision. The rotational clearance is specified in angular minutes in the chapter "Geometrically possible combinations". The rotational clearance for the output shaft is specified without load (max. 1% of the rated output torque); the gear unit input end is blocked. For information on the combination tables, refer to chapter "Structure of the combination tables" (→ 142).

The reduced backlash design is available for the following gear units:

- Helical gear units (R), sizes 37 to 167
- Parallel-shaft helical gear units (F), sizes 37 to 157
- Helical-bevel gear units (K), sizes 37 to 187

Compound gear units are not available with reduced backlash.

The dimensions of the reduced backlash designs correspond to the dimensions of the standard designs, except for parallel-shaft helical gear units FH.87 and FH.97 with reduced backlash.

The following figure shows the dimensions of FH.87 and FH.97 gear units with reduced backlash:

42 020 00 09

FH../R
FH..B/R

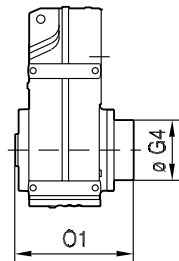

FHF../R

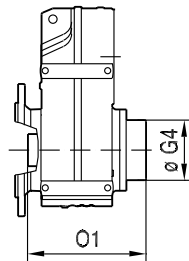

FHZ../R

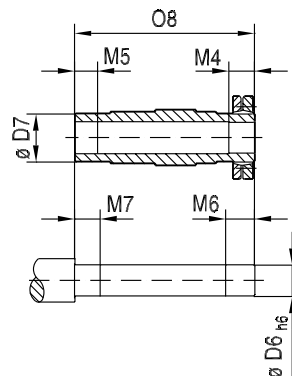
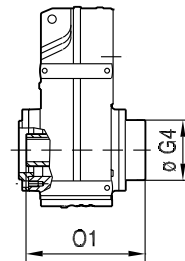

6644506891

Type	Dimensions in mm								
	D6	D7	G4	M4	M5	M6	M7	O1	O8
FH.87/R	Ø 65 _{h6}	Ø 85	Ø 163	41	40	46	45	312.5	299.5
FH.97/R	Ø 75 _{h6}	Ø 95	Ø 184	55	50	60	55	382.5	367

6.4 Installation/removal of gear units with hollow shaft and key

INFORMATION



Use the supplied NOCO® fluid for assembly. The fluid facilitates removal as it prevents contact corrosion.

The key dimension X is specified by the customers, but $X > DK$ must apply (DK = Diameter of customer shaft).

See figure "Customer shaft with and without contact shoulder".

6.4.1 Installation

SEW-EURODRIVE recommends 2 variants for installing gear units with hollow shaft and key onto the input shaft of the driven machine (= customer shaft):

1. Use the fastening parts supplied for installation.
2. Use the optional installation/removal kit for installation.

Supplied fastening parts

The following fastening parts are provided as standard:

- Retaining screw with washer [2]
- Retaining ring [3]

Note the following information concerning the customer shaft:

- The installation length of the customer shaft with contact shoulder [A] must be $L8 - 1 \text{ mm}$.
- The installation length of the customer shaft without contact shoulder [B] must equal L8.

The following figure shows the customer shaft with contact shoulder [A] and without contact shoulder [B].

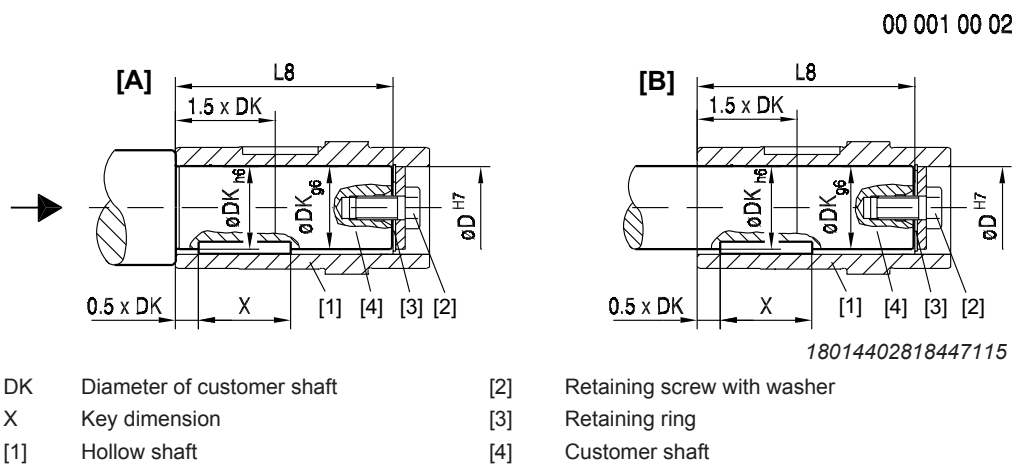

Dimensions and tightening torque:

Tightening torques MS for the retaining screw [2]:

Gear unit type	D ^{H7} mm	DK mm	L8 mm	MS Nm
WA..10	16		69	8
WA..20	18		84	
WA..20				
KA..19	20		92	20
FA..27	25		89	
KA..29			107	
KA..29	30		107	20
WA..30, WA..37	20		105	8
SA..37			104	
FA..37, KA..37, SA..47	30		105	20
KA..39			137	
KA..39	35			
KA..49			160	
KA..49	40		154	
SA..47, WA..37	25		105	
FA..47, KA..47, SA..57	35		132	
WA..47	30		122	40
SA..57			132	
FA..57, KA..57	40		142	
FA..67, KA..67			156	
SA..67			144	
SA..67	45			
FA..77, KA..77, SA..77	50		183	
SA..77			180	80
FA..87, KA..87	60		210	
SA..87			220	
SA..87	70			
FA..97, KA..97	70		270	
SA..97			260	200
FA..107, KA..107	80		313	
SA..97			255	
FA..107, KA..107	90		313	
FA..127, KA..127	100		373	
FA..157, KA..157	120		460	

Installation/removal kit

You can use the optional installation/removal kit for installation. This can be ordered for the specific gear unit types by quoting the part numbers in the following table. The delivery includes:

- Spacer tube for installation without contact shoulder [5]
- Retaining screw for installation [2]
- Forcing washer for removal [7]
- Locked nut for removal [8]

The short retaining screw delivered as standard is not required.

Note the following information concerning the customer shaft:

- The installation length of the customer shaft must be LK2. **Do not use the spacer tube** if the customer shaft **has a contact shoulder [A]**.
- The installation length of the customer shaft must be LK2. Use the spacer tube if the customer shaft **has no contact shoulder [B]**.

The following figure shows the customer shaft with contact shoulder [A] and without contact shoulder [B].

00 002 00 02

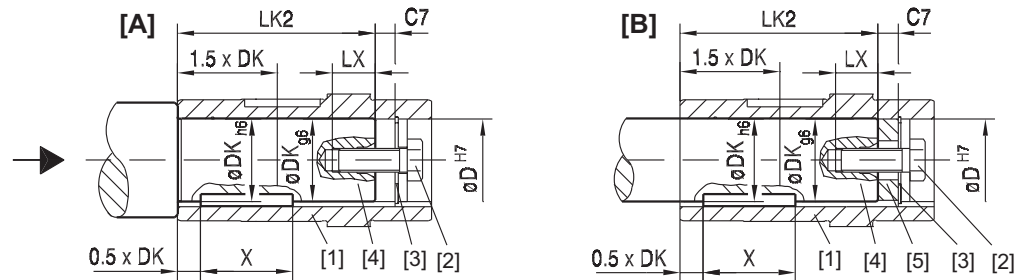

18014402818449035

- | | | | |
|-----|-----------------------------|-----|----------------|
| DK | Diameter of customer shaft | [3] | Retaining ring |
| X | Key dimension | [4] | Customer shaft |
| [1] | Hollow shaft | [5] | Spacer tube |
| [2] | Retaining screw with washer | | |

Dimensions, tightening torques and part numbers:

Tightening torques MS for the retaining screw [2]:

Type	D ^{H7} mm	DK mm	LK2 mm	LX ⁺² mm	C7 mm	MS Nm	Part number of the installation/ removal kit
WA..10	16	58	12.5	11	8	6437125	
WA..20	18	72	16	12			
WA..20	20	72					
WA..30, WA..37	20	93					
SA..37	20	92					
KA..19	20	80					
KA..29	25	91			22	16	20
FA..27	25	73					
SA..47, WA..37	25	89					
WA..47	30	106					
FA..37, KA..37	30	89					
SA..47	30	89					
SA..57	30	116	22	16	20	6436854	
KA..29	30	91					
KA..39	30	121					
KA..39	35	119					
FA..47, KA..47, SA..57	35	114					
KA..49	35	142					
KA..49	40	136	36	18	40	6436870	
FA..57, KA..57	40	124					
FA..67	40	138					
KA..67	40	138					
SA..67	40	126					
SA..67	45	126					
FA..77, KA..77, SA..77	50	165				6436889	
							6436897

20272545/EN – 11/2015

Type	D ^{H7} mm	DK mm	LK2 mm	LX ⁺² mm	C7 mm	MS Nm	Part number of the installation/ removal kit			
FA..87, KA..87	60		188	42	22	80	6436900			
SA..77			158							
SA..87			198							
FA..97, KA..97	70		248	42	26	80	6436919			
SA..87			198							
SA..97			238							
FA..107, KA..107	80		287	42	26	80	10682112			
FA..107, KA..107	90		287	50	26	200	6436927			
SA..97			229							
FA..127, KA..127	100		347				50	26	200	6436935
FA..157, KA..157	120		434							6436943

6.4.2 Removal

Applies only if the installation/removal kit was previously used for installation.

1. Loosen the retaining screw [6].
2. Remove the retaining ring [3] and, if used, the spacer tube [5].
3. Insert the forcing washer [7] and the fixed nut [8] between the customer shaft [4] and retaining ring [3] as shown in the following figure.
4. Re-insert the retaining ring [3].
5. Re-install the retaining screw [6]. Now you can force the gear unit off the shaft.

The following figure shows the removal of a gear unit with hollow shaft and key.

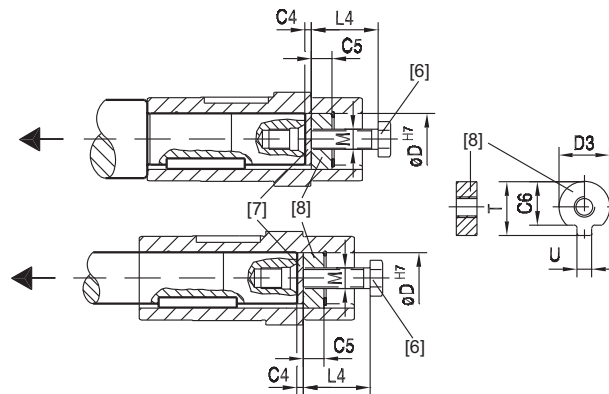

9007208437413131

- [6] Retaining screw
 [7] Forcing washer
 [8] Locked nut for removal

Dimensions and part numbers:

Type	D ^{H7} mm	M	C4 mm	C5 mm	C6 mm	U ^{-0.5} mm	T ^{-0.5} mm	D3 ^{-0.5} mm	L4 mm	Part number of the installation/re- moval kit
WA..10	16	M5	5	5	12	4.5	18	15.7	50	6437125
WA..20	18	M6	5	6	13.5	5.5	20.5	17.7	25	643682X
WA..20, WA..30, SA..37, WA..37, KA..19	20		5		15.5		22.5			6436838
FA..27, SA..47, WA..47, KA..29	25	M10	5	10	20	7.5	28	24.7	35	6436846
FA..37, KA..29, KA..37, KA..39, SA..47, SA..57, WA..47,	30		5		25		33			29.7

Type	D ^{H7} mm	M	C4 mm	C5 mm	C6 mm	U ^{-0.5} mm	T ^{-0.5} mm	D3 ^{-0.5} mm	L4 mm	Part number of the installation/re- moval kit
FA..47, KA..39, KA..47, KA..49, SA..57	35	M12	5	12	29	9.5	38	34.7	45	6436862
FA..57, KA..57, FA..67, KA..49, KA..67, SA..67	40	M16	5		34	11.5	41.9	39.7	50	6436870
SA..67	45		5		38.5	13.5	48.5	44.7		6436889
FA..77, KA..77, SA..77	50		5	43.5	53.5		49.7	6436897		
FA..87, KA..87, SA..77, SA..87	60	M20	5	16	56	17.5	64	59.7	60	6436900
FA..97, KA..97, SA..87, SA..97	70		5		65.5	19.5	74.5	69.7		6436919
FA..107, KA..107	80		M24	5	20	75.5	21.5	85	79.7	70
FA..107, KA..107, SA..97	90	5		80		24.5	95	89.7	6436927	
FA..127, KA..127	100	5		89		27.5	106	99.7	6436935	
FA..157, KA..157	120	5		107		31	127	119.7	6436943	

6.5 Gear units with hollow shaft

6.5.1 Chamfers on hollow shafts

The following illustration shows the chamfers on parallel-shaft helical, helical-bevel, helical-worm and SPIROPLAN® gear units with hollow shaft:

00 004 002

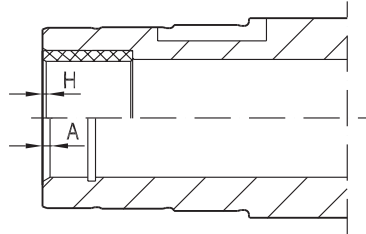

4309448843

Gear unit	Design	
	with hollow shaft (A)	with hollow shaft and shrink disk (H)
W..10	1.5 × 30°	-
W..20		-
W..30		-
F..27		
K..19		0.5 × 45°
K..29		
F../K../S../W..37		
K..39	2 × 30°	-
F../K../S../W..47		0.5 × 45°
K..49		-
S..57		
F../K..57		
F../K../S..67		
F../K../S..77		
F../K../S..87		
F../K../S..97	3 × 30°	0.5 × 45°
F../K..107		
F../K..127		
F../K..157	5 × 30°	
KH167	-	
KH187	-	

6.5.2 Special motor/gear unit combinations

Please note for parallel-shaft helical gearmotors with hollow shaft (FA..B, FV..B, FH..B, FAF, FVF, FHF, FA, FV, FH, FT, FAZ, FVZ, FHZ):

- If you are using a customer shaft pushed through on the motor end, there may be a collision when a "small gear unit" is used in combination with a "large motor."
- Check the motor dimension AC to decide whether there will be a collision with a pushed-through customer shaft.

6.6 TorqLOC® mounting system for gear units with hollow shaft

6.6.1 Description of TorqLOC®

The TorqLOC® hollow shaft mounting system is used for achieving a non-positive connection between the customer's shaft and the hollow shaft in the gear unit. The TorqLOC® hollow shaft mounting system is an alternative to the hollow shaft with shrink disk, the hollow shaft with key and the splined hollow shaft that have been used so far.

The TorqLOC® hollow shaft mounting system consists of the following components:

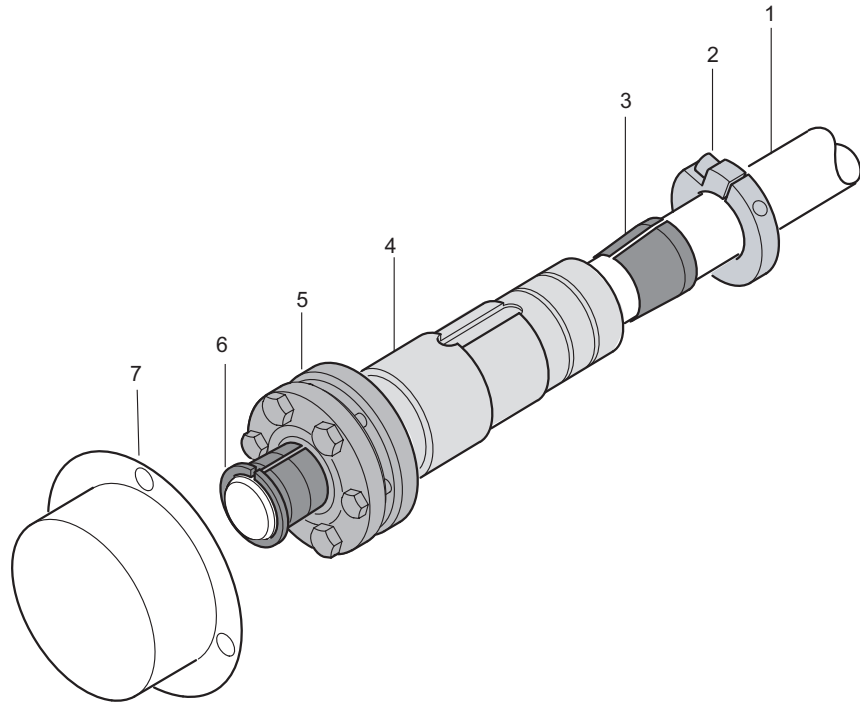

4309625867

[1]	Customer shaft	[5]	Shrink disk
[2]	Clamping ring	[6]	Conical steel bushing
[3]	Conical bronze bushing	[7]	Fixed hood cover
[4]	Hollow shaft in gear unit		

6.6.2 Benefits of TorqLOC®

The TorqLOC® hollow shaft mounting system provides the following advantages:

- Cost saving because the customer shaft can be made from drawn material up to quality h11.
- Cost saving because different customer shaft diameters can be covered by one hollow shaft diameter and different bushings.
- Simple installation since there is no need to accommodate any shaft connections.
- Simple removal even after many hours of operation because the formation of contact corrosion has been reduced and the conical connections can easily be released.

6.6.3 Technical data of TorqLOC®

The TorqLOC® hollow shaft mounting system is approved for input torques of 92 Nm to 18 000 Nm.

The following gear units are available with TorqLOC® hollow shaft mounting system:

- Parallel-shaft helical gear units in gear unit sizes 37 to 157 (FT37 – FT157)
- Helical-bevel gear units in gear unit sizes 37 to 157 (KT37 – KT157), 39 and 49 (KT39, KT49)
- Helical-worm gear units in gear unit sizes 37 to 97 (ST37 – ST97)
- SPIROPLAN® gear unit sizes 37 and 47 (WT.7)

Available options

The following options are available for gear units with a TorqLOC® hollow shaft mounting system:

- For helical-bevel, helical-worm and SPIROPLAN® gear units (KT.., ST.., WT.7..): "torque arm" option (../T)
- For parallel-shaft helical gear units (FT..): "rubber buffer" option (../G)

6.7 Shouldered hollow shaft option with shrink disk

The following gear units with a hollow shaft and shrink disk are also available with an optional larger bore diameter D':

- Parallel-shaft helical gear units FH/FHF/FHZ37 – 157
- Helical-bevel gear units KH/KHF/KHZ37 – 157
- Helical-worm gear units SH/SHF47 – 97

D' = D as standard.

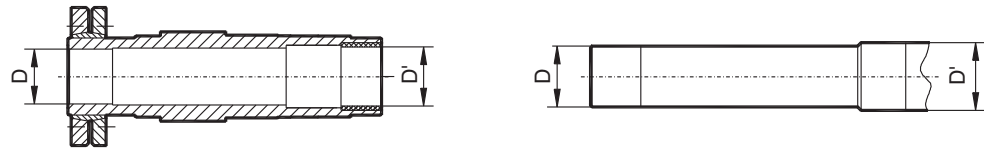

4987055371

Gear units	Bore diameter D / optionally D' mm
FH/FHF/FHZ37, KH/KHF/KHZ37, SH/SHF/SHZ47	30 / 32
FH/FHF/FHZ47, KH/KHF/KHZ47, SH/SHF/SHZ57	35 / 36
FH/FHF/FHZ57, KH/KHF/KHZ57	40 / 42
FH/FHF/FHZ67, KH/KHF/KHZ67, SH/SHF/SHZ67	40 / 42
FH/FHF/FHZ77, KH/KHF/KHZ77, SH/SHF/SHZ77	50 / 52
FH/FHF/FHZ87, KH/KHF/KHZ87, SH/SHF/SHZ87	65 / 66
FH/FHF/FHZ97, KH/KHF/KHZ97, SH/SHF/SHZ97	75 / 76
FH/FHF/FHZ107, KH/KHF/KHZ107	95 / 96
FH/FHF/FHZ127, KH/KHF/KHZ127	105 / 106
FH/FHF/FHZ157, KH/KHF/KHZ157	125 / 126

Diameter D / D' must be specified when ordering gear units with a shouldered hollow shaft (optional bore diameter D').

6.7.1 Sample order

FH37 DRK90M4 with hollow shaft 30/32 mm

6.7.2 Parallel-shaft helical gear units with shouldered hollow shaft (dimensions in mm):

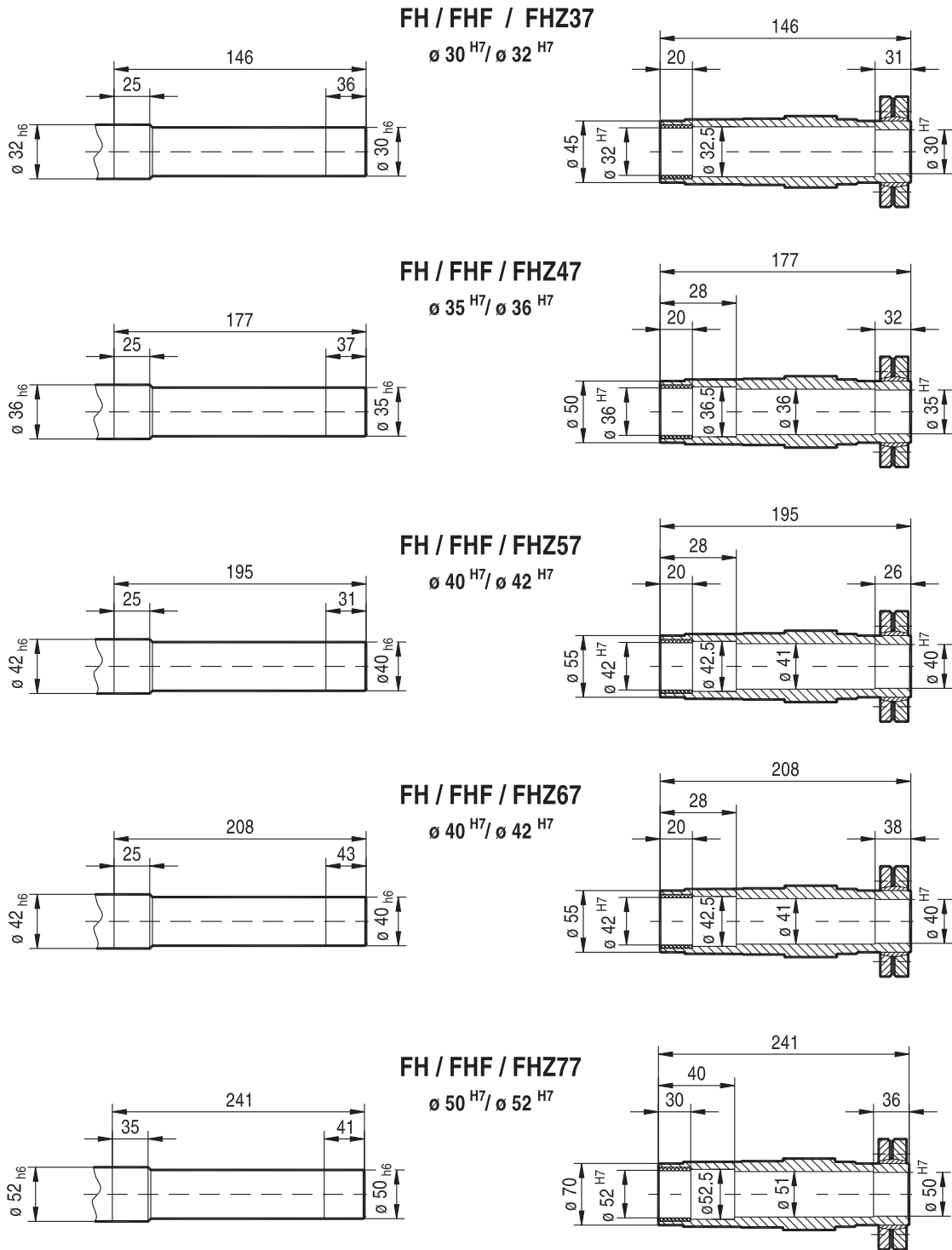

4987059083

20272545/EN – 11/2015

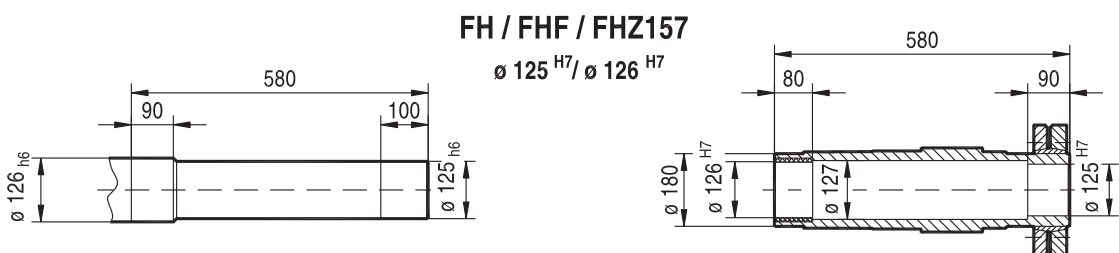
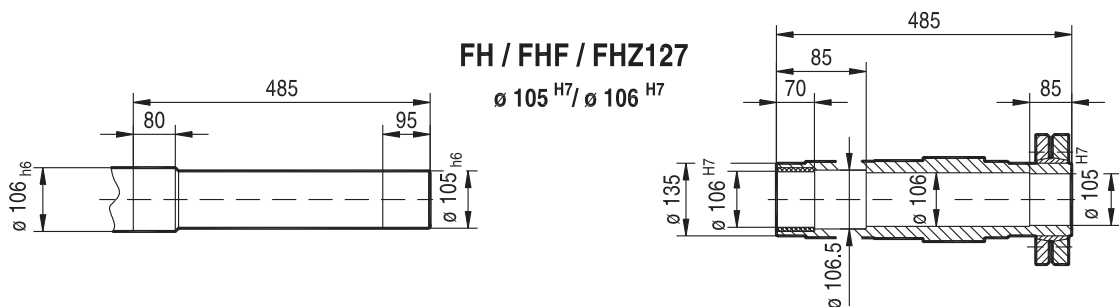
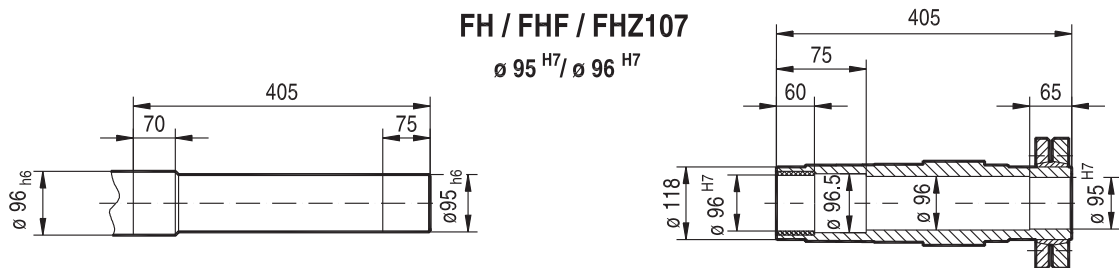
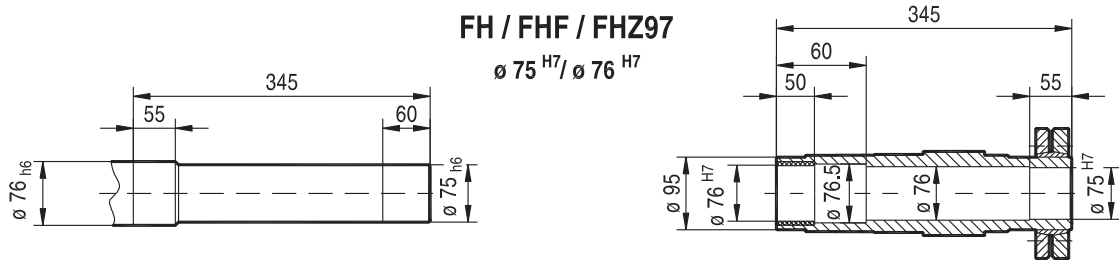
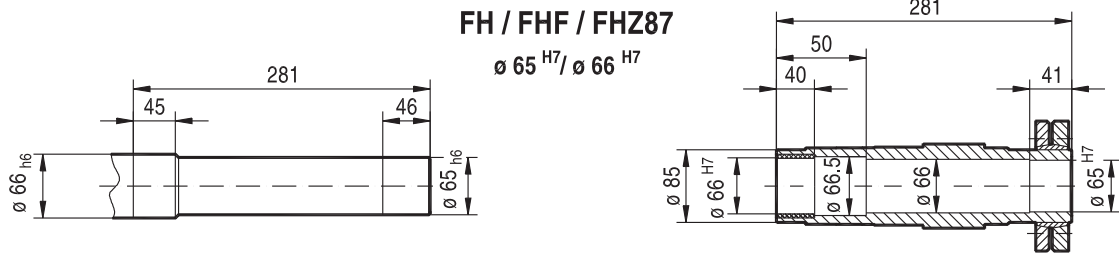

4987060747

6.7.3 Helical-bevel gear units with shouldered hollow shaft (dimensions in mm):

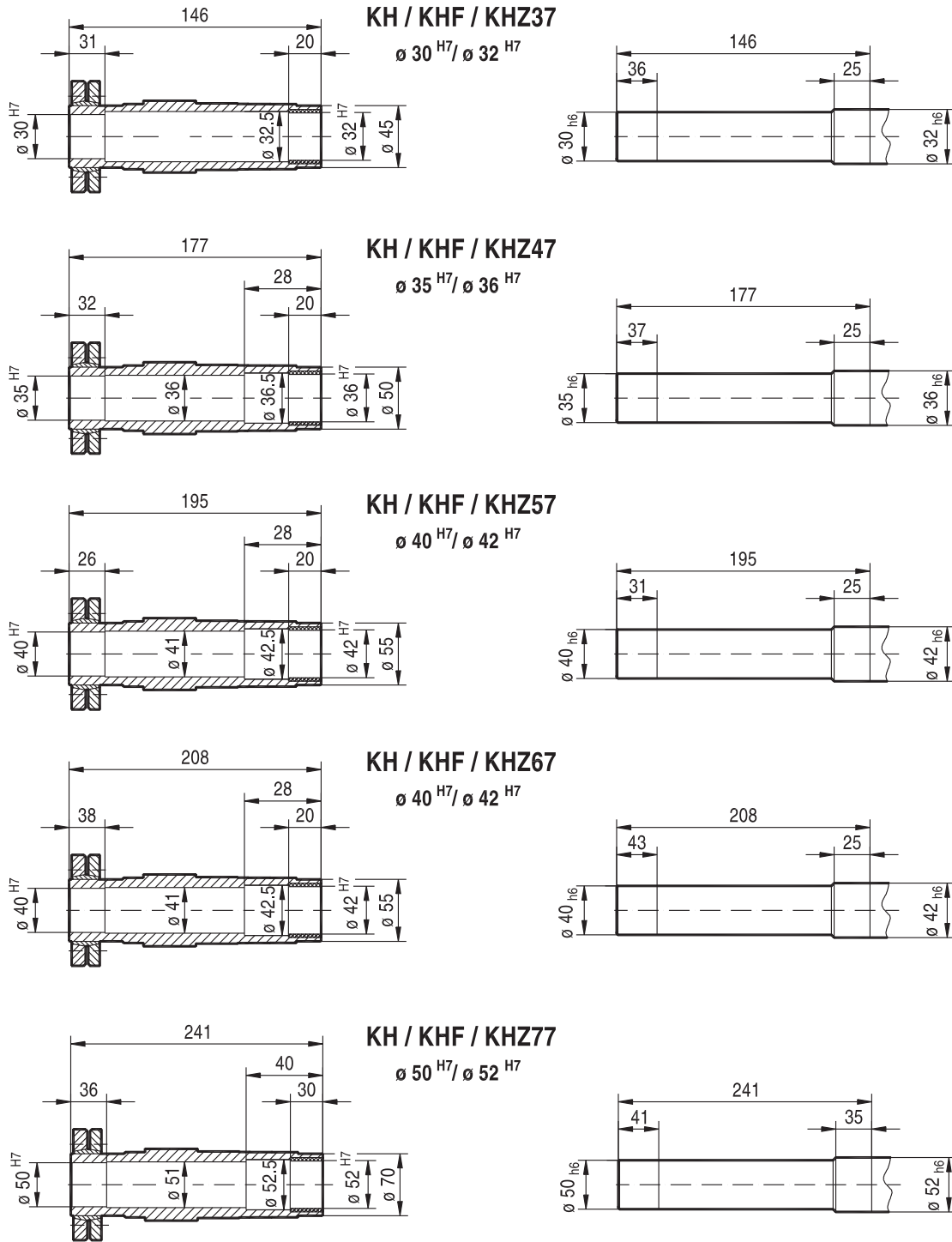

4987063435

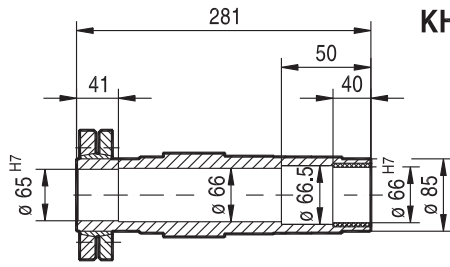

KH / KHF / KHZ87
 $\varnothing 65^{H7} / \varnothing 66^{H7}$

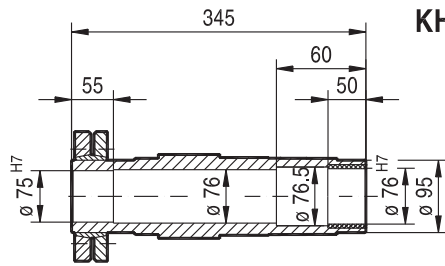
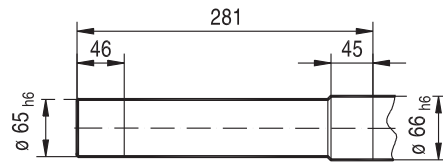

KH / KHF / KHZ97
 $\varnothing 75^{H7} / \varnothing 76^{H7}$

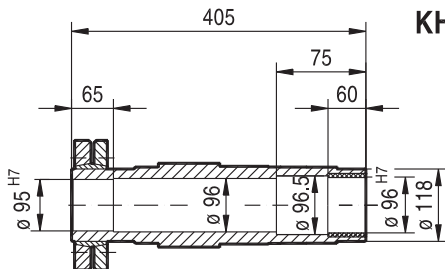
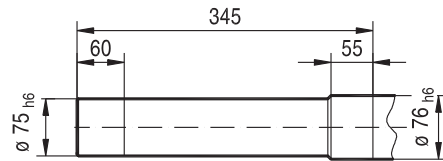

KH / KHF / KHZ107
 $\varnothing 95^{H7} / \varnothing 96^{H7}$

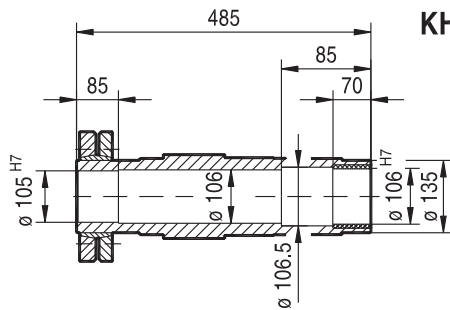
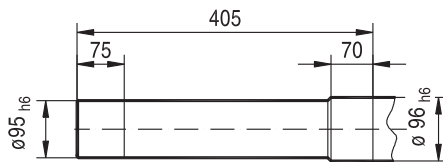

KH / KHF / KHZ127
 $\varnothing 105^{H7} / \varnothing 106^{H7}$

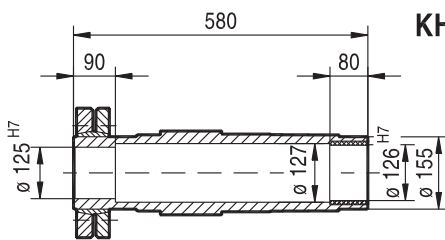
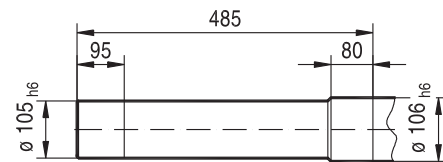

KH / KHF / KHZ157
 $\varnothing 125^{H7} / \varnothing 126^{H7}$

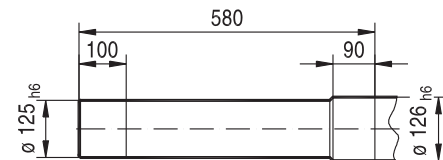

4987065099

6.7.4 Helical-worm gear units with shouldered hollow shaft (dimensions in mm):

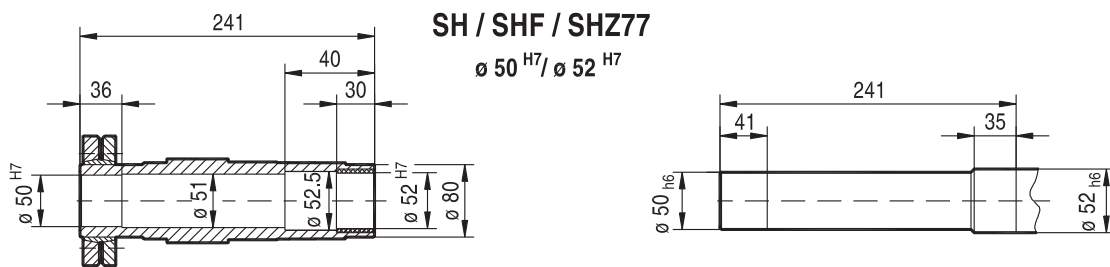
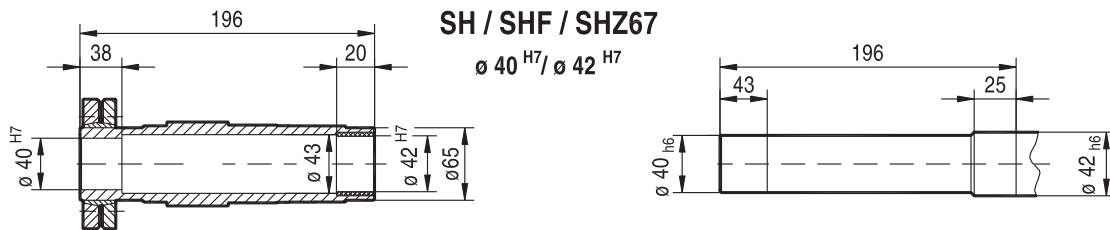
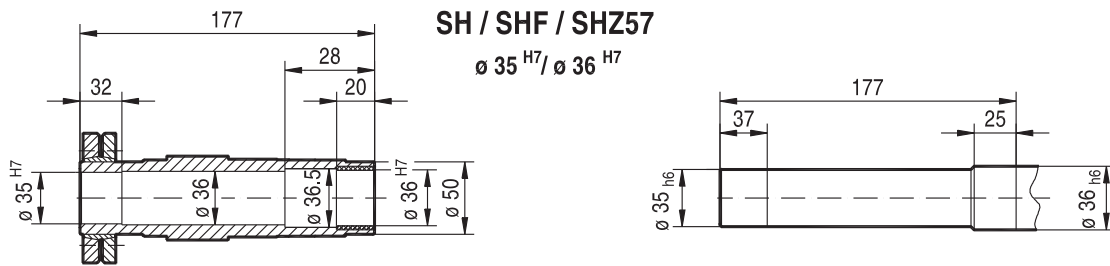
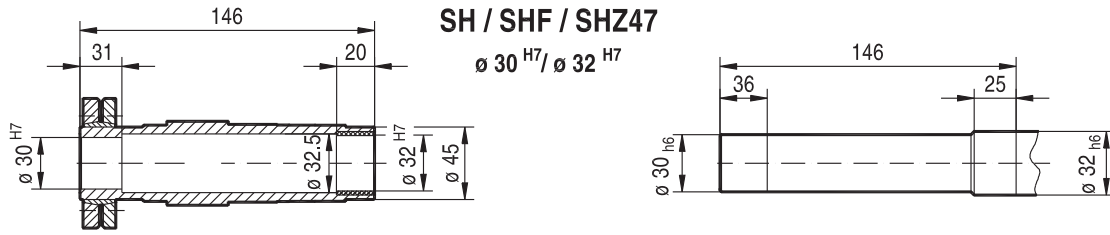

4987067787

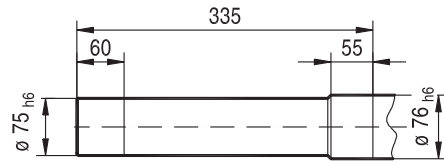
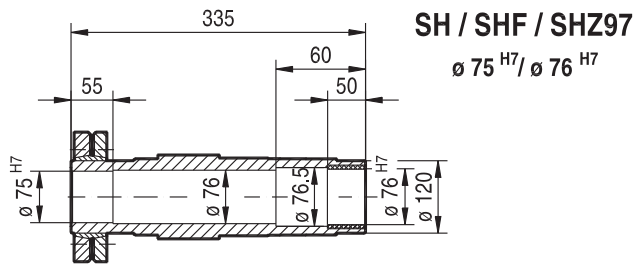
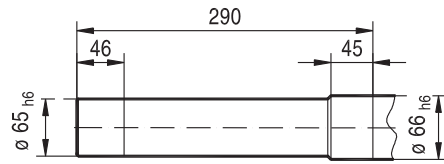
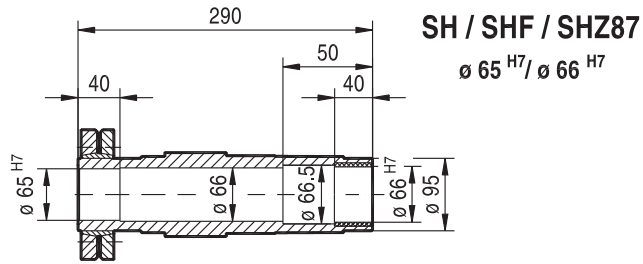

4987069451

6 Design and operating notes

Adapters for mounting IEC motors

6.8 Adapters for mounting IEC motors

23 002 100

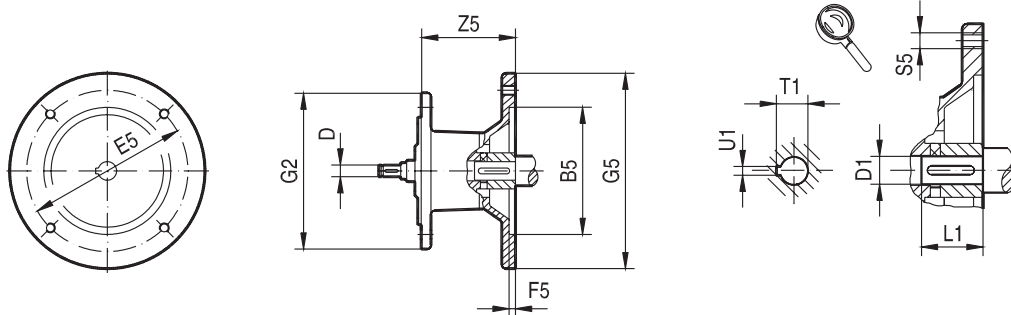

9007204242190859

Gear unit type	Adapter type	Dimensions in mm											
		B5	D	E5	F5	G2	G5	S5	Z5	D1	L1	T1	U1
R..27, R..37 F..27, F..37, F..47 K..19, K..29, K..37 S..37, S..47, S..57 W..37	AM63	95	10	115	3.5	120	140	M8	72	11	23	12.8	4
	AM71 ¹⁾	110		130	4		160			14	30	16.3	5
	AM80 ¹⁾	130	12	165	4.5		200	M10	19	40	21.8	6	
	AM90 ¹⁾		14						24	50	27.3	8	
R..47 ²⁾ , R..57, R..67 F..57, F..67 K..39, K..47 ²⁾ , K..57, K..67 S..67 W..47 ³⁾	AM63	95	10	115	3.5	160	140	M8	66	11	23	12.8	4
	AM71	110		130	4		160			14	30	16.3	5
	AM80	130	12	165	4.5		200	M10	19	40	21.8	6	
	AM90		14						24	50	27.3	8	
	AM100 ¹⁾	180	16	215	5		250	M12	28	60	31.3	8	
	AM112 ¹⁾		18						300	38	80	41.3	10
AM132S/M ¹⁾	230	22	265				191	38	80	41.3	10		
R..77 F..77 K..49, K..77 S..77	AM63	95	10	115	3.5	200	140	M8	60	11	23	12.8	4
	AM71	110		130	4		160			14	30	16.3	5
	AM80	130	12	165	4.5		200	M10	19	40	21.8	6	
	AM90		14						24	50	27.3	8	
	AM100 ¹⁾	180	16	215	5		250	M12	126	28	60	31.3	8
	AM112 ¹⁾		18						179	38	80	41.3	10
	AM132S/M ¹⁾	230	22	265									
AM132ML ¹⁾	28												
R..87 F..87 K..87 S..87 ⁴⁾	AM80	130	12	165	4.5	250	200	M10	87	19	40	21.8	6
	AM90		14							24	50	27.3	8
	AM100	180	16	215	5		250	M12	121	28	60	31.3	8
	AM112		18										
	AM132S/M	230	22	265			300		174	38	80	41.3	10
	AM132ML		28										
	AM160 ¹⁾	250	28	300	6		350	M16	232	42	110	45.3	12
AM180 ¹⁾	32		48			51.8			14				

1) Check dimension 1/2 G5 because component may protrude past foot-mounting surface if installed on R, K, S or W foot-mounted gear unit.

2) Maximum AM100

3) Maximum AM90

4) Not with AM180

20272545/EN – 11/2015

23 003 100

Fig.1

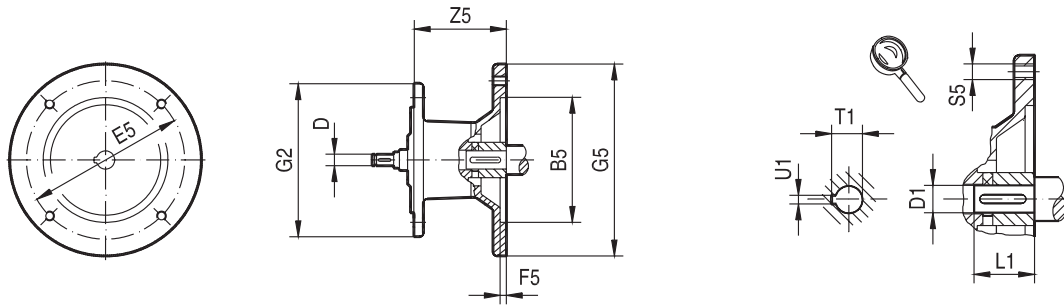
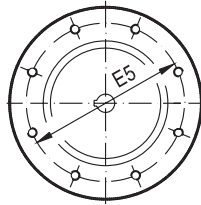

Fig.2



9007204242194571

Gear unit type	Adapter type	Fig.	Dimensions in mm												
			B5	D	E5	F5	G2	G5	S5	Z5	D1	L1	T1	U1	
R..97 F..97 K..97 S..97 ¹⁾	AM100	1	180	16	215	5	300	250	M12	116	28	60	31.3	8	
	AM112			18											
	AM132S/M		230	22	265	6		350	M16	227	42	48	110	45.3	12
	AM132ML			28											
	AM160		250	32	300	7		400	M16	268	55	59.3	16		
	AM180			38											
	AM200		300	38	350	7		400	268	55	59.3	16			
R..107 F..107 K..107	AM100	1	180	16	215	5	350	250	M12	110	28	60	31.3	8	
	AM112			18											
	AM132S/M		230	22	265	6		400	M16	221	42	48	110	45.3	12
	AM132ML			28											
	AM160		250	32	300	7		450	M16	262	55	59.3	16		
	AM180			38											
	AM200		300	38	350	7		450	262	55	59.3	16			
AM225	2	350	400	7	450	277	60	140	64.4	18					
R..137	AM132S/M	1	230	22	265	5	400	300	M12	156	38	80	41.3	10	
	AM132ML			28											
	AM160		250	32	300	6		400	M16	214	42	48	110	45.3	12
	AM180			38											
	AM200	300	38	350	7	400		255	55	59.3	16				
	AM225	2	350	400	7	450		270	60	140	64.4	18			

1) Not with AM200

6 Design and operating notes

Adapters for mounting IEC motors

23 004 100

Fig.1

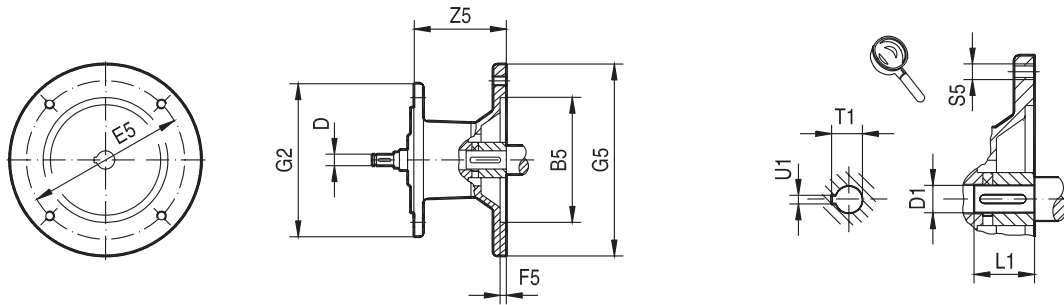
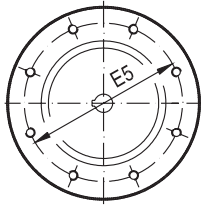

Fig.2



4987456011

Gear unit type	Adapter type	Fig.	Dimensions in mm													
			B5	D	E5	F5	G2	G5	S5	Z5	D1	L1	T1	U1		
R..147 F..127 K..127	AM132S/M	1	230	22	265	5	450	300	M12	148	38	80	41.3	10		
	AM132ML			28												
	AM160	250	28	300	6	350		206	42	110	45.3	12				
	AM180		32													
	AM200	300	38	350	7	400		247	55	59.3	16					
	AM225											350	400			
	AM250	450	48	500	7	450		262	60	64.4	18					
	AM280											336	65	140	69.4	18
R..167 F..157 K..157 K..167 K..187	AM160	1	250	28	300	6	550	350	M16	198	42	110	45.3	12		
	AM180			32												
	AM200	300	38	350	7	400		239	55	59.3	16					
	AM225											350	400			
	AM250	450	48	500	7	450		254	60	64.4	18					
	AM280											328	65	140	69.4	18

6.9 Adapters for mounting NEMA motors

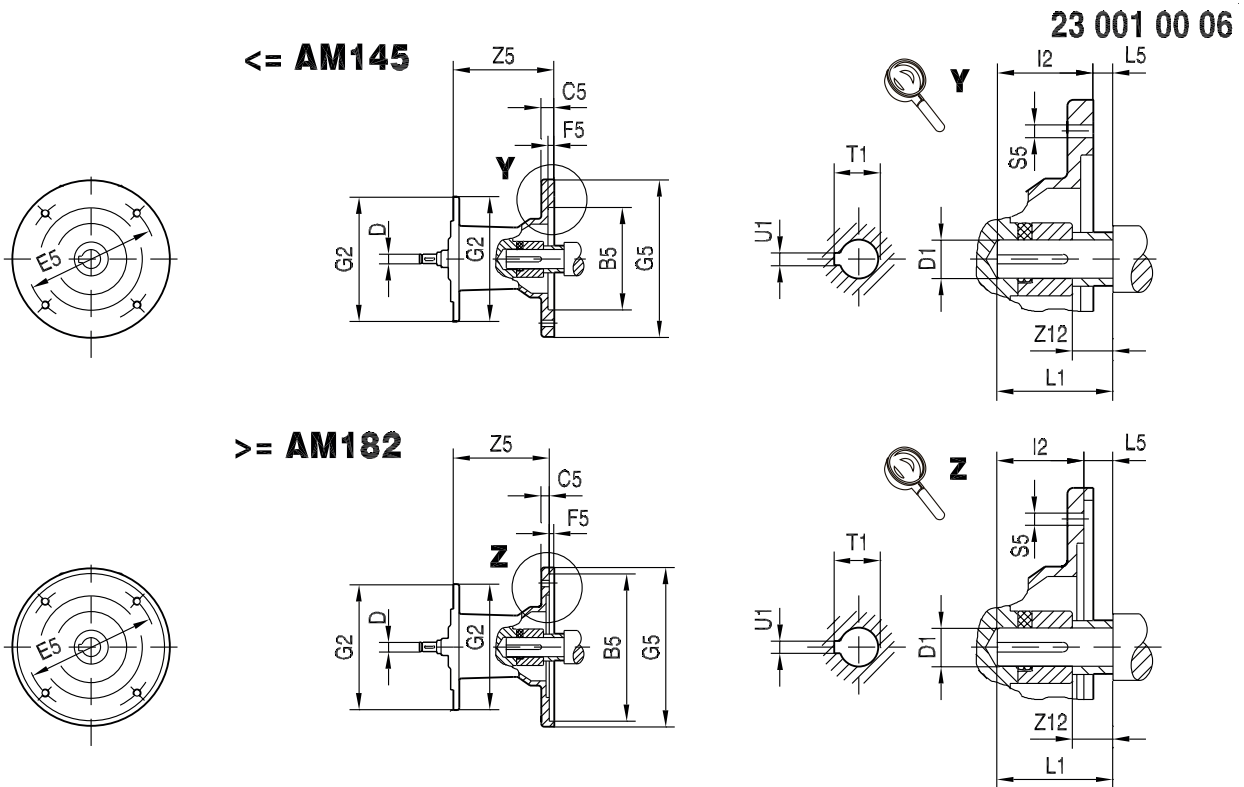

Gear unit type	Adapter type	Dimensions in mm															
		B5	C5	D	E5	F5	G2	G5	I2	L5	S5	Z5	Z12	D1	L1	T1	U1
R..27, R..37 F..27, F..37, F..47 K..19, K..29, K..37 S..37, S..47, S..57 W..37	AM56	114.3	11	10	149.2	4.5	120	170	52.55	-4.8	10.5	93.5	16.5	15,875	47	18.1	4.76
	AM143		12	12					54.1	3		117	14.5	22,225	57	24.7	
	AM145		12	14					54.1	3		110.5	14.5	22,225	57	24.7	
R..47, R..57, R..67 F..57, F..67 K..39, K..47, K..57, K..67 S..67 W..47 ¹⁾	AM56	215.9	11	10	184	5	160	228	52.55	-4.8	15	87	16.5	15,875	47	18.1	6.35
	AM143		12	12					54.1	3		110.5	14.5	22,225	57	24.7	
	AM145		12	14					54.1	3		110.5	14.5	22,225	57	24.7	
	AM182	10	16	66.85	3	147.5	16.5	28,575	69	31.7	6.35						
	AM184	11	18	79.55	6.3	200.5	15.8	34,925	85	38.7	7.94						
	AM213/215	11	22	79.55	6.3	200.5	15.8	34,925	85	38.7	7.94						
R..77 F..77 K..49, K..77 S..77	AM56	114.3	11	10	149.2	4.5	200	170	52.55	-4.8	10.5	81	16.5	15,875	47	18.1	4.76
	AM143		12	12					54.1	3		103.5	14.5	22,225	57	24.7	
	AM145		12	14					54.1	3		103.5	14.5	22,225	57	24.7	
	AM182	10	16	66.85	3	139.5	16.5	28,575	69	31.7	6.35						
	AM184	11	18	79.55	6.3	188.5	15.8	34,925	85	38.7	7.94						
R..87 F..87 K..87 S..87	AM143	114.3	12	12	149.2	4.5	250	170	54.1	3	10.5	98.5	14.5	22,225	57	24.7	4.76
	AM145		12	14					54.1	3		98.5	14.5	22,225	57	24.7	
	AM182	10	16	66.85	3	134.5	16.5	28,575	69	31.7	6.35						
	AM184	11	18	79.55	6.3	183.5	15.8	34,925	85	38.7	7.94						
	AM213/215	11	22	95.3	6.3	234	8.8	41,275	101	45.8	9.53						
	AM254/256	12	28	95.3	6.3	234	8.8	41,275	101	45.8	9.53						
AM284/286	266.7	15	32	228.6		286	111.05	6.3	15	241	15.8	47,625	117	53.4	12.7		

1) Maximum AM143/AM145

20272545/EN – 11/2015

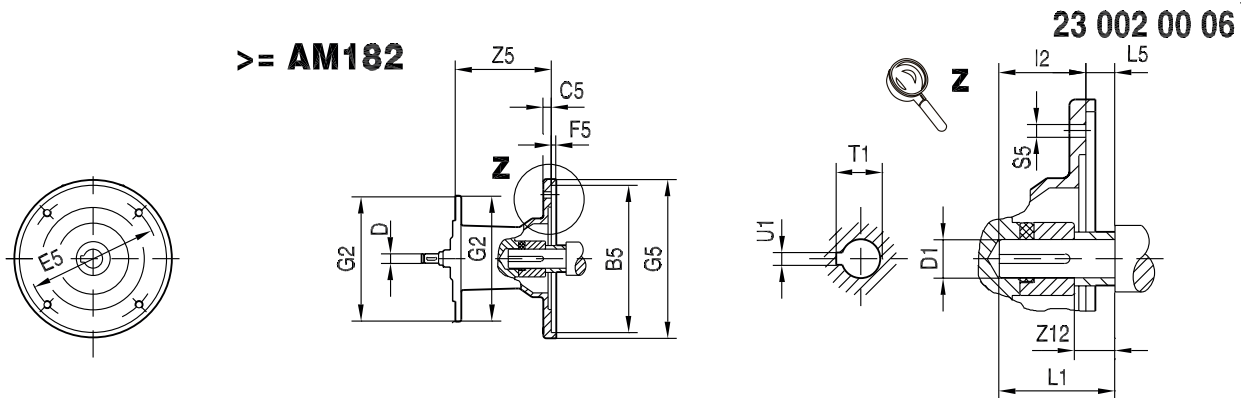

9007204242133899

Gear unit type	Adapter type	Dimensions in mm																	
		B5	C5	D	E5	F5	G2	G5	I2	L5	S5	Z5	Z12	D1	L1	T1	U1		
R..97 F..97 K..97 S..97	AM182	215.9	10	16	184	5	300	228	66.85	3	15	129.5	16.5	28,575	69	31.7	6.35		
	AM184			18															
	AM213/215	11	22																
	AM254/256	12	28																
	AM284/286	266.7	20	32	228.6														
	AM324/326	317.5	17	38	279.4														
	AM364/365							17.5	296	34.8	53,975	133	60	12.7					
R..107 F..107 K..107	AM182	215.9	10	16	184	5	350	228	66.85	3	15	123.5	16.5	28,575	69.85	31.7	6.35		
AM184	18																		
AM213/215	11	22																	
AM254/256	12	28																	
AM284/286	266.7	15	32	228.6															
AM324/326	317.5	17	38	279.4															
AM364/365					17.5			290	34.8	53,975	133.35	60	12.7						
R..137	AM213/215	215.9	11	22	184	5	400	228	79.55	6.3	15	165.5	15.8	34,925	85.85	38.7	7.94		
AM254/256	12			28															
AM284/286	266.7	15	32	228.6															
AM324/326	317.5	17	38	279.4															
AM364/365					17.5			283	34.8	53,975	133.35	60	12.7						
R..147 F..127 K..127	AM213/215	215.9	11	22	184			5	450	228	79.55	6.3	15	157.5	15.8	34,925	85.85	38.7	7.94
AM254/256	12			28															
AM284/286	266.7	15	32	228.6															
AM324/326	317.5	17	38	279.4															
AM364/365					17.5	275	34.8			53,975	133.35	60	12.7						
R..167 F..157 K..157 K..167 K..187	AM254/256	215.9	12	28	184	5	550			228	95.3	15	200	8.8	41,275	101.6	45.8	9.53	
AM284/286	266.7	15	32	228.6															
AM324/326	317.5	17	38	279.4															
AM364/365					17.5			267	34.8	53,975	133.35	60	12.7						

6.10 Gear unit mounting

Strength class of the screws

Always mount gearmotors using screws of strength class 8.8.

The gearmotors in flange-mounted design and in foot-/flange-mounted design listed in the following table are an exception. Always use screws of strength class 10.9 for these gearmotors. Use suitable washers.

Gear unit	Flange Ø in mm	Strength class of the screws
RF37/R37F	120	10.9
RF47/R47F	140	
RF57/R57F	160	
FF/FAF77/KF/KAF77	250	
RF147	450	
RF167	550	
RZ37 – RZ87	60ZR – 130ZR	

6.11 Torque arms

6.11.1 Available torque arms



NOTICE

Danger due to static overdetermination if gear units with foot (e.g. KA19/29B, KA127/157B or FA127/157B) are mounted both via the torque arm and via the foot plate.

Risk of injuries and damage to property.

- Especially with the KA.9B/T design, it is not permitted to use the foot plates and the torque arm at the same time.
- Attach the KA.9B/T design only via the torque arm.
- Attach the K.9 or KA.9B design only via the foot plate.
- If you want to use foot plates and torque arms for mounting, contact SEW-EURODRIVE.

The following table lists the part numbers of available torque arms.

Gear unit	Size			
	19	29	39	49
KA, KH, KT	10684115	10684107	10682163	06442439

Gear unit	Size					
	27	37	47	57	67	77
KA, KH, KV, KT	-	6434258	6434282	6434312	6434312	6434347
SA, SH, ST	-	1269941	6442374	6442404	6442439	6442463
FA, FH, FV, FT Rubber buffer (2 pieces)	0133485	0133485	0133485	0133485	0133485	0133493

Gear unit	Size				
	87	97	107	127	157
KA, KH, KV, KT	6434371	6434401	6434436	6432948	-
SA, SH, ST	6442498	6442528	-	-	-
FA, FH, FV, FT Rubber buffer (2 pieces)	0133493	0133507	0133507	0133515	0133477

Gear unit	Size				
	10	20	30	37	47
WA, WH, WT	10610219	1680730	1680110	10611290	10611851

6.11.2 Available torque arms

**NOTICE**

Danger due to static overdetermination if gear units with foot (e.g. KA19/29B, KA127/157B or FA127/157B) are mounted both via the torque arm and via the foot plate.

Risk of injuries and damage to property.

- Especially with the KA.9B/T design, it is not permitted to use the foot plates and the torque arm at the same time.
- Attach the KA.9B/T design only via the torque arm.
- Attach the K.9 or KA.9B design only via the foot plate.
- If you want to use foot plates and torque arms for mounting, contact SEW-EURODRIVE.

The following table lists the part numbers of available torque arms.

Gear unit	Size			
	19	29	39	49
KA, KH, KT	10684115	10684107	10682163	06442439

Gear unit	Size					
	27	37	47	57	67	77
KA, KH, KV, KT	-	6434258	6434282	6434312	6434312	6434347
FA, FH, FV, FT Rubber buffer (2 pieces)	0133485	0133485	0133485	0133485	0133485	0133493

Gear unit	Size				
	87	97	107	127	157
KA, KH, KV, KT	6434371	6434401	6434436	6432948	-
FA, FH, FV, FT Rubber buffer (2 pieces)	0133493	0133507	0133507	0133515	0133477

Gear unit	Size				
	10	20	30	37	47
WA, WH, WT	10610219	1680730	1680110	10611290	10611851

6.11.3 Torque arms for KH167.., KH187..

As standard, torque arms are not available for gear unit sizes KH167.. and KH187... Consult SEW-EURODRIVE if you need torque arms for these gear units.

6.12 Flange contours of RF.. and R..F gear units

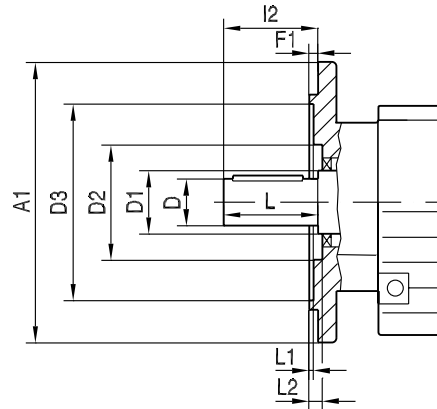

Check dimensions L1 and L2 for selection and installation of output elements.

Type	Dimensions in mm											
	A1	D	D1	D2		D3	F1	I2	L	L1		L2
				RF	R..F					RF	R..F	
RF07, R07F	120	20	22	38	38	72	3	40	40	2	2	6
	140 ¹⁾				-	85					-	
	160 ¹⁾				-	100					-	
RF17, R17F	120	25	25	46	46	65	3	50	50	1	1	5
	140				-	78					-	
	160 ¹⁾				-	95					-	
RF27, R27F	120	25	30	54	54	66	3	60	60	1	1	6
	140				-	79					-	
	160				-	92					-	
RF37, R37F	120	30	35	60	63	70	3	70	70	5	4	7.5
	160				-	96					-	
	200 ¹⁾				-	119					-	
RF47, R47F	140	30	35	72	64	82	3	60	60	4	1	6
	160				-	96					-	
	200				-	116					-	
RF57, R57F	160	35	40	76	75	96	3.5	70	70	4	2.5	5
	200				-	116					-	
	250 ¹⁾				-	160					-	
RF67, R67F	200	50	50	90	90	118	3.5	80	80	2	4	7
	250				-	160					-	
	-				-	160					-	
RF77, R77F	250	40	52	112	100	160	4	100	100	0.5	2.5	7
	300 ¹⁾				-	210					-	
	-				-	210					-	
RF87, R87F	300	50	62	123	122	210	5	120	120	0	1.5	8
	350				-	226					-	
	450				-	236					-	
RF97	350	60	72	136	-	232	5	140	140	0	-	11
	450				-	320					-	
	-				-	316					-	
RF107	450	70	82	157	-	316	5	170	170	0	-	10
RF137	550	90	108	180	-	416	5	210	210	0	-	10
RF147	450	110	125	210	-	316	5	210	210	0	-	10
RF167	550	120	145	290	-	416	6	210	210	1	-	11
	660				-	517					-	

1) The flange contour protrudes from under the base surface.

6.13 Flange contours of FF..., KF..., SF... and WF... gear units

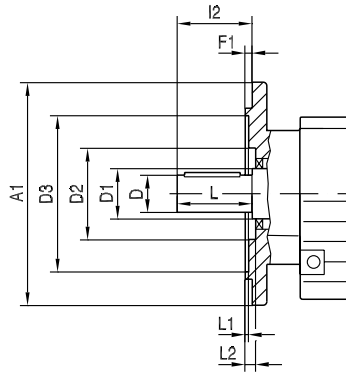

9007203564915467

Check dimensions L1 and L2 for selection and installation of output elements.

Type	Dimensions in mm									
	A1	D	D1	D2	D3	F1	I2	L	L1	L2
FF27	160	25	40	66	96	3.5	50	50	3	18.5
FF37			30	70	94				2	6
FF47	200	30	40	72	115	4	60	60	3.5	7.5
FF57	250	35		84	155		70	70	4	9
FF67	250	40	50	82	205	4	80	80		
FF77	300	50	55				115	220	100	100
FF87	350	60	65	115	220	5	120	120	8	10
FF97	450	70	75	112	320		140	140		
FF107		90	100	159	318	5	170	170	16	9
FF127	550	110	118	-	420		6	210	210	10
FF157	660	120	135	190	520	6		210	210	8
KF19	120	20	25	-	70	2.5	40	40	-	11.5
	160				100					
KF29	200	25	30	-	109	3.5	50	50	-	6.5
	160				115					
KF37	160	30	39	68	96	3.5	60	60	2	6
KF39				70	94				13.5	23.5
KF47	200	35	49	72	115	4	70	70	3.5	7.5
KF49				76	115				24.5	28
KF57	250	40	50	84	155	4	70	70	4	9
KF67										
KF77	300	50	55	82	205	5	100	100	5	9
KF87	350	60	65	115	220		120	120		
KF97	450	70	75	112	320	5	140	140	8	10
KF107		90	100	159	318		170	170	16	9
KF127	550	110	118	-	420	6	210	210	10	-
KF157	660	120	135	190	520		6	210	210	8
SF37	120	20	25	-	68	3	40	40	6	-
	160	20		-	96				5.5	
SF47	200	25	30	70	94	3.5	50	50	2	6
SF57				72	115				3.5	7.5
SF67	250	35	45	-	-	4	70	70	8.5	-
SF77				108	160				4	90
SF87	350	60	65	130	220	5	120	120	6	10
SF97	450	70	75	150	320		5	140	140	
WF10	80	16	25	-	39	2.5	40	40	30	-
	120		25	39	74	3			5	30

20272545/EN – 11/2015

6

Design and operating notes

Flange contours of FF.., KF.., SF.. and WF.. gear units

Type	Dimensions in mm									
	A1	D	D1	D2	D3	F1	I2	L	L1	L2
WF20	110	20	30	44	53	-4	40	40	27	35
	120			-	45	37.5			-	
160				48	63	2.5			18	27
	120			-	70	-			10.5	
25.5										
WF37	120	30	35	-	92	3.5	10	60	6	-
WF47	160								6	-

6.14 Flange contours of FAF..., KAF..., SAF.. and WAF.. gear units

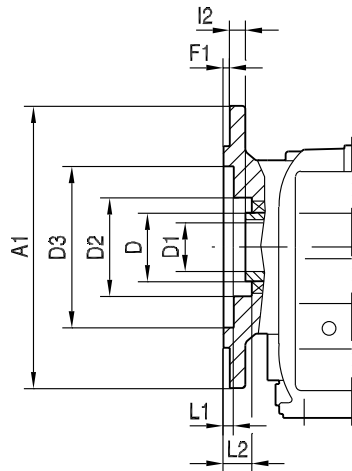

18014402819885835

Check dimensions L1 and L2 for selection and installation of output elements.

Type	Dimensions in mm								
	A1	D	D1	D2	D3	F1	I2	L1	L2
FAF27	160	40	25	66	96	3.5	20	3	18.5
FAF37		45	30	62	94		24	2	30
FAF47	200	50	35	70	115	4	25	3.5	31.5
FAF57	250	55	40	76	155		23.5	4	31
FAF67						23			
FAF77	300	70	50	95	205	5	37	5	45
FAF87	350	85	60	120	220		30		39
FAF97	450	95	70	135	320	5	41.5	5.5	51
FAF107		118	90	224			41		
FAF127	550	135	100	185	420	6	51	6	63
FAF157	660	155	120	200	520		60		
KAF19	120	30	20	60	70	2.5	25	9	25.5
	160				100				
KAF29	160	40	25 / 30	-	105	3.5	33.5	-	6.5
	200			-	118				
KAF39	160	50	30 / 35	68	96	3.5	24.5	10	27
KAF37	160	45	30	62	94		24		
KAF47	200	50	35	70	115	3.5	25	3.5	8.5
KAF49	200	55	35 / 40	76	115		32.5		
KAF57	250	55	40	76	155	4	23.5	4	31
KAF67							23		
KAF77	300	70	50	95	205	5	37	5	45
KAF87	350	85	60	120	220		30		39
KAF97	450	95	70	135	320	5	41.5	5.5	51
KAF107		118	90	224			41		
KAF127	550	135	100	185	420	6	51	6	63
KAF157	660	155	120	200	520		60		
SAF37	120	35	20	-	68	3	15	6	-
	160				96				
SAF47	160	45	30 / 25	62	94	3.5	24	2	30
SAF57	200	50	35 / 30	70	115		25		
SAF67		65	45 / 40	91		42.5	4	48.5	
SAF77	250	80	60 / 50	112	164	4	45.5	5	53.5
SAF87	350	95	70 / 60	131	220	5	52.5	6	62.5

20272545/EN – 11/2015

6

Design and operating notes

Flange contours of FAF..., KAF..., SAF.. and WAF.. gear units

Type	Dimensions in mm								
	A1	D	D1	D2	D3	F1	I2	L1	L2
SAF97	450	120	90 / 70	160	320	5	60	6.5	69
WAF10	80	25	16	-	39	2.5	23	30	-
	120			39	74	3		5	30
WAF20	110	30	18 / 20	44	53	-4	30	27	35
	120			-	45	2.5		19.5	37.5
160			20	48	63		34.5		18
	63				34.5		33	42	
WAF37	120	35	20 / 25	54	70		2.5	19.5	10.5
	160					45			25 / 30
45		25 / 30	72	92	3.5		10	6	

20272545/EN – 11/2015

6.15 Covers

6.15.1 Rotating cover

The following gear unit types with hollow shaft and shrink disk are equipped with a rotating cover as standard:

Gear unit type	Sizes
KH..	19 – 29 and 37 – 97
FH.., SH.., WH..	37 – 97

6

6.15.2 Fixed plastic cover

The following gear unit types with hollow shaft and shrink disk are equipped with a rotating plastic cover as standard:

Gear unit type	Sizes
FH..	27 and 107 – 157
KH..	107 – 157

Should you require a fixed plastic cover for other gear unit types or sizes, the part number required to order the cover can be found in the following chapter.

6.15.3 Fixed sheet metal cover

The following gear unit types with hollow shaft and shrink disk are equipped with a fixed sheet metal cover as standard:

Gear unit type	Sizes
KH..	167 and 187
FT.., KT.., ST.., WT.. (with TorqLOC [®] hollow shaft mounting system)	All available sizes
Explosion-proof gear units FH.., KH.., SH.., WH.. gear units	All available sizes

Should you require a fixed sheet metal cover for other gear unit types or sizes, the part number required to order the cover can be found in the following chapter.

6.15.4 Maximum motor mounting sizes with fixed cover

In case of parallel-shaft helical gear units the size of the attached motor may be limited by the use of a fixed cover.

Fixed plastic cover

The following table shows the maximum possible motor mounting surface, depending in the gear unit size, for a fixed plastic cover:

Gear unit size	F..37	F..47	F..57	F..67	F..77	F..87	F..97
Maximum possible motor mounting sizes	71M	80M	90L	112M	132L	160L	180L

Fixed sheet metal cover

The following table shows the maximum possible motor mounting surface, depending in the gear unit size, for a fixed sheet metal cover:

Gear unit size	F..37	F..47	F..57	F..67	F..77	F..87	F..97
Maximum possible motor mounting sizes	71M	71M	80M	100L	132L	160L	180L

6.15.5 Part numbers and dimensions for fixed plastic covers

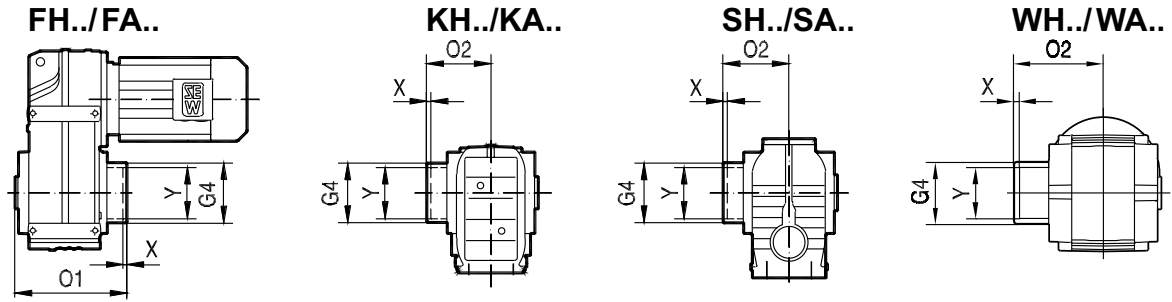

14436693643

Parallel-shaft helical gearmotors	FH/FA ..37	FH/FA ..47	FH/FA ..57	FH/FA ..67	FH/FA ..77	FH/FA ..87	FH/FA ..97
Part number	6435130	6435149	6435157	6435157	6435165	6435173	6435181
G4 in mm	78	88	100	100	121	164	185
O1 in mm	157	188.5	207.5	221.5	255	295	363.5
X in mm	2	4.5	7.5	6	6	4	6.5
Y in mm	75	83	83	93	114	159	174

Helical-bevel gearmotors	KH/KA ..19	KH/KA ..29
Part number	1068415 8	1068416 6
G4 in mm	62	68
O2 in mm	83	90
X in mm	2	4
Y in mm	50	60

Helical-bevel gearmotors ¹⁾	KH/KA ..37	KH/KA ..47	KH/KA ..57	KH/KA ..67	KH/KA ..77	KH/KA ..87	KH/KA ..97
Part number	6435130	6435149	6435157	6435157	6435165	6435173	6435181
G4 in mm	78	88	100	100	121	164	185
O2 in mm	95	111.5	122.5	129	147	172	210.5
X in mm	0	1.5	5.5	3	1	2	4.5
Y in mm	75	83	83	93	114	159	174

1) Not possible in foot-mounted helical-bevel gear units with hollow shafts (KH..B and KA..B).

Helical-worm gearmotors	SH/SA ..37	SH/SA ..47	SH/SA ..57	SH/SA ..67	SH/SA ..77	SH/SA ..87	SH/SA ..97
Part number	6435122	6435130	6435149	6435157	6435165	6435173	6435181
G4 in mm	59	78	88	100	121	164	185
O2 in mm	88	95	111.5	123	147	176	204.5
X in mm	1	0	1.5	3	1	0	0.5
Y in mm	53	75	83	93	114	159	174

SPIROPLAN® gearmotors	WH/WA ..37	WH/WA ..47
Part number	1061136 3	10611940
G4 in mm	68	80.5
O2 in mm	95.5	109.5
X in mm	11	12.5
Y in mm	50	72

20272545/EN – 11/2015

6 Design and operating notes

Covers

6.15.6 Part numbers and dimensions for fixed sheet metal covers

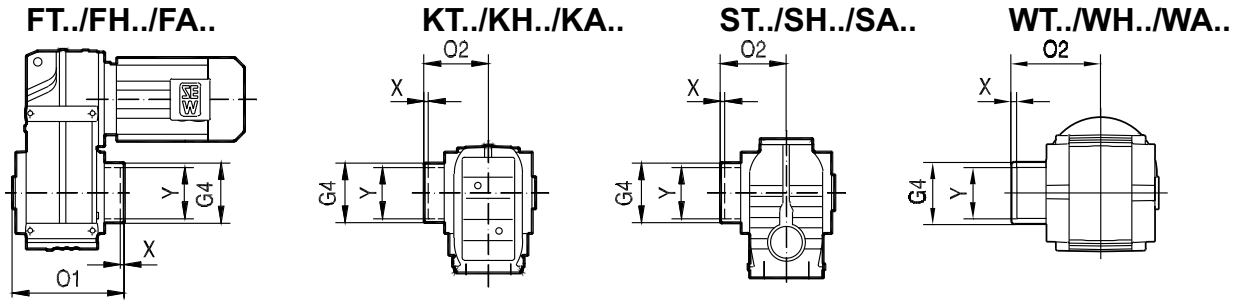

18014407696567179

Parallel-shaft helical gearmotors	FT/FH/FA ..37	FT/FH/FA ..47	FT/FH/FA ..57	FT/FH/FA ..67	FT/FH/FA ..77	FT/FH/FA ..87	FT/FH/FA ..97	FT/FH/FA ..107	FT/FH/FA ..127	FT/FH/FA 157
Part number	0643584X	06435858	06435866	06435866	06435874	06435882	06435890	06421814	06421822	06421830
G4 in mm	81	90	101	101	124	165	200	196	229	275
O1 in mm	166	199	222	236	285	322	382	421	502	605
X in mm	1.5	1.5	1.5	1.5	1.5	1.5	1.5	1.5	1.5	1.5
Y in mm	78	87	98	98	121	162	197	193	226	272

Helical-bevel gear-motors	KH/KA ..19	KH/KA ..29	KT/KA ..39	KT/KA ..49
Part number	06442595	10631259	10682651	10682964
G4 in mm	62	68	86	97
O2 in mm	83	90	117.5	138
X in mm	1.5	1.5	1	1
Y in mm	80	87	84	95

Helical-bevel gear-motors ¹⁾	KT/KH/ KA ..37	KT/KH/ KA ..47	KT/KH/ KA ..57	KT/KH/ KA ..67	KT/KH/ KA ..77	KT/KH/ KA ..87	KT/KH/ KA ..97	KT/KH/ KA ..107	KT/KH/ KA ..127	KT/KH/ KA ..157
Part number	0643584X	06435858	06435866	06435866	06435874	06435882	06435890	06421814	06421822	06421879
G4 in mm	81	90	101	101	124	165	200	196	229	275
O2 in mm	104	122	137	143	177	229	382	246	297	375
X in mm	1.5	1.5	1.5	1.5	1.5	1.5	1.5	1.5	1.5	1.5
Y in mm	78	87	98	98	121	162	197	193	226	272

1) Not possible in foot-mounted helical-bevel gear units with hollow shafts (KH..B and KA..B)

Helical-worm gear-motors	ST/SH/SA ..37	ST/SH/SA ..47	ST/SH/SA ..57	ST/SH/SA ..67	ST/SH/SA ..77	ST/SH/SA ..87	ST/SH/SA ..97
Part number	06444768	0643584X	06435858	06435866	06435874	06435882	06435882
G4 in mm	64	81	90	101	124	165	165
O2 in mm	98	104	122	137	177	203	223
X in mm	1.5	1.5	1.5	1.5	1.5	1.5	1.5
Y in mm	61	78	87	98	121	162	162

SPIROPLAN® gear-motors	WT/WH/ WA ..37	WT/WH/ WA ..47
Part number	10611479	10611959
G4 in mm	67	78
O2 in mm	95.5	109
X in mm	1	1
Y in mm	64	76

20272545/EN – 11/2015

6.16 Condition monitoring: Oil aging sensor

6.16.1 Technical data of oil aging sensor

DUO10A diagnostic unit



DUO10A	Technical data		
Preset oil grades	OIL1	CLP mineral oil.	$T_{max} = 100\text{ °C}$
		Bio oil	$T_{max} = 100\text{ °C}$
	OIL2	CLP HC synthetic oil:	$T_{max} = 130\text{ °C}$
		CLP PAO oil	$T_{max} = 130\text{ °C}$
	OIL3	Polyglycol CLP PG	$T_{max} = 130\text{ °C}$
OIL4	Food grade oil	$T_{max} = 100\text{ °C}$	
Switch outputs	1: Early warning (time to next oil change can be set to between 2 and 100 days) 2: Main alarm (time to oil change 0 days) 3: Maximum temperature exceeded T_{max} 4: DUO10A is ready for operation		
Permitted oil temperature	-40 °C – +130 °C		
Permitted temperature sensor	PT1000		
EMC	IEC1000-4-2/3/4/6		
Ambient temperature	-25 °C – +70 °C		
Operating voltage	DC 18 – 28 V		
Current consumption for DC 24 V	< 90 mA		
Protection class	III		
Degree of protection	IP67 (optionally IP69K)		
Housing materials	Evaluation unit: V2A, EPDM/X, PBT, FPM Temperature sensor: V4A		
Electrical connection	Evaluation unit: M12 plug connector PT1000 temperature sensor: M12 plug connector		

6

Design and operating notes

Condition monitoring: Oil aging sensor

Designations and part numbers

Designation	Description	Part number
 DUO10A	Evaluation unit (basic unit)	13438751
DUO10A-PUR-M12-5m	5 m PUR cable with 1 connector	13438778
DUO10A-PVC-M12-5m	5 m PVC cable with 1 connector	13438786
DUO10A	Angle bracket	13438808
DUO10A D = 34	Mounting clamp	13438794
 W4843 PT1000	PT1000 temperature sensor	13438816
W4843_4x0,34-2m-PUR	2 m PUR cable for PT1000 ¹⁾	13438824
W4843_4x0,34-2m-PVC	2 m PVC cable for PT1000 ²⁾	13438832
 DUO10A	Protection cap (for aseptic design, IP69K)	13439022

1) PUR cables are particularly suited for use in oil-contaminated environments.

2) PVC cables are particularly suited for use in moist environments.

20272545/EN – 11/2015

Mounting to standard gear units (R, F, K,S)

Adapter for mounting the PT1000 temperature sensor in screw plug holes:

Complete adapter for PT1000 sensor	Part number
M10 × 1	13439030
M12 × 1.5	13439049
M22 × 1.5	13439057
M33 × 2	13439065
M42 × 2	13439073

Mounting base for installing the diagnostic unit at the gear unit with an angle bracket:

Mounting base with sealing ring	Part number
M10 × 1	13434411
M12 × 1.5	13438271
M22 × 1.5	13438298
M33 × 2	13438301
M42 × 2	13438328

7 Important information on selection tables and dimension drawings

Possible geometrical combinations

7 Important information on selection tables and dimension drawings

7.1 Possible geometrical combinations

7.1.1 Structure of the combination tables

These tables show geometrically possible combinations of single-speed gear units and AC (brake) motors. Contact SEW-EURODRIVE for information on pole-changing AC (brake) motors.

For each combination, the input speed $n_e = 1400$ 1/min and the output speed n_a , the maximum output torque M_{amax} , the permitted overhung load F_{Ra} at maximum output torque (valid for foot-mounted gear units with solid shaft), the torsion angle ϕ (/R) and the gear unit ratio are specified.

If no value is specified for the torsion angle $\phi_{(/R)}$, the gear unit with this gear unit ratio is not available with "reduced backlash (/R)" option. If a numerical value is given, this gear unit is also available with "reduced backlash (/R)" option. The numerical value specifies the rotational clearance of the reduced backlash version in angular minutes '.

R77, $n_e = 1400$ 1/min					820Nm		
n_a rpm	M_{amax} Nm	$F_{Ra}^{1)}$ N	$\phi_{(/R)}$	i	ER63S ER63M DRK71S DRK71M	DRK80S DRK80M DRK90M	DRK90L
 3							
7.2	820	9920	6.4	195.24*			
8.4	820	9920	6.5	166.59			

Gear unit ratio; values marked with * indicate infinite gear unit ratio.

Not specified (-): For this i , the option with reduced backlash (/R) is not possible.

Numerical value given: Option reduced backlash is possible. the numerical value specifies the rotational clearance of the reduced backlash version in angular minutes.

Permitted overhung load at maximum output torque M_{amax}

Maximum output torque of the gear unit

Output speed

¹⁾ This value refers to the foot-mounted design with solid shaft.

 Combination with the motor in the header **is possible**.

 Combination with the motor in the header **is not possible**.

12116567435



Number of stages of the gear ratios (1, 2 or 3 stages). Helical gear units (R) – with the exception of the single-stage RX gear units – and parallel-shaft helical gear units (F) have 2 or 3 stages, depending on the gear unit ratio.

RX helical, helical-bevel, helical-worm and SPIROPLAN® gear units (RX, K, S, and W) have a defined number of stages:

- RX helical gear units: RX.. always single-stage
- Helical-bevel gear unit: K..7 always 3-stage, K..9 always 2-stage

20272545/EN – 11/2015

- Helical-worm gear units: always 2-stage
- SPIROPLAN® gear units: W..10 to W..30 always single-stage, W..37 and W..47 always 2-stage

7.2 Selection tables for gearmotors

7.2.1 Structure of the selection tables

The two figures below illustrate the structure of the selection tables for gearmotors. There are two types of selection tables:

1. For standard output speeds, sorted by the rated power P_m of the driving motor in kW
2. For extremely low output speeds, always compound gearmotors sorted by the maximum permitted output torque M_{amax} in Nm.

Table for standard output speeds:

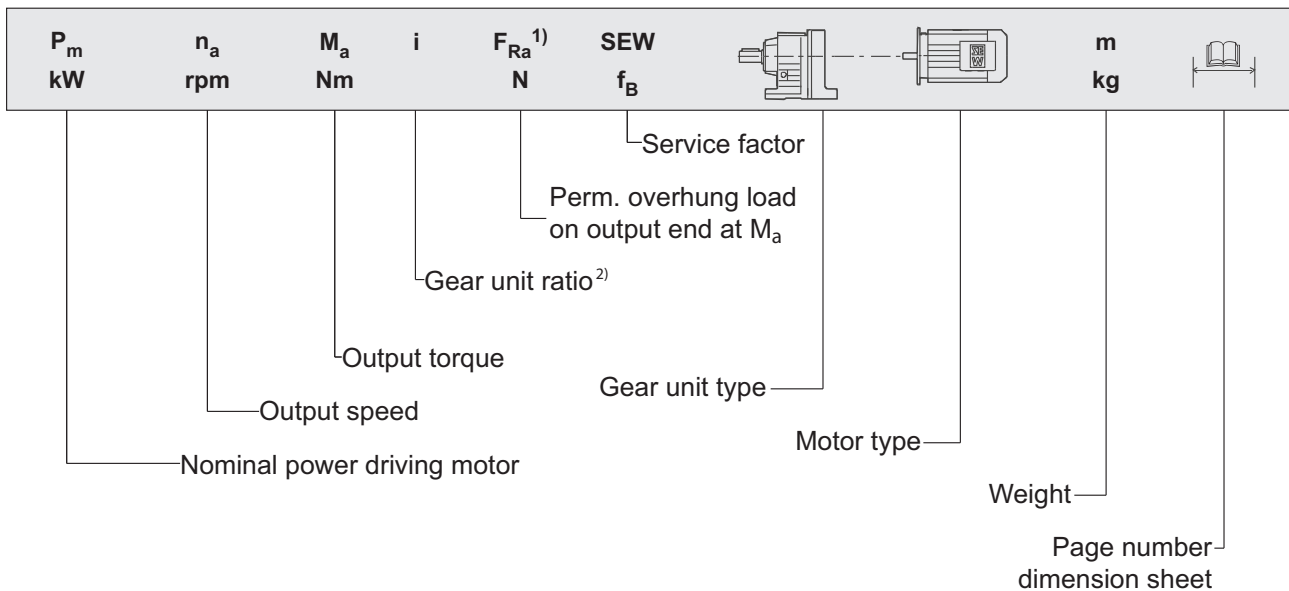

18014410461306123

¹⁾ Overhung load for foot-mounted gear units with solid shaft; overhung loads for other design types upon request.

²⁾ A value marked with * indicates finite gear unit ratio.

INFORMATION



Only applies to SPIROPLAN® (W) gearmotors:

If a lubricant is used for the food industry (food grade), a service factor SEW $f_B \geq 1.2$ required.

7.3 Dimension sheet information

7.3.1 Symbols for scope of delivery



Standard parts supplied by SEW-EURODRIVE.



Standard parts not supplied by SEW-EURODRIVE.

7.3.2 Tolerances

Shaft heights

The following tolerances apply to the indicated dimensions:

$h \leq 250 \text{ mm} \rightarrow -0.5 \text{ mm}$

$h > 250 \text{ mm} \rightarrow -1 \text{ mm}$

Foot-mounted gear units: Check the mounted motor because it may project below the mounting surface.

Shaft ends

Diameter tolerance:

$\emptyset \leq 50 \text{ mm} \rightarrow \text{ISO k6}$

$\emptyset > 50 \text{ mm} \rightarrow \text{ISO m6}$

Centering bores according to DIN 332, shape DR:

$\emptyset = 7 - 10 \text{ mm} \rightarrow \text{M3}$

$\emptyset > 10 - 13 \text{ mm} \rightarrow \text{M4}$

$\emptyset > 13 - 16 \text{ mm} \rightarrow \text{M5}$

$\emptyset > 16 - 21 \text{ mm} \rightarrow \text{M6}$

$\emptyset > 21 - 24 \text{ mm} \rightarrow \text{M8}$

$\emptyset > 24 - 30 \text{ mm} \rightarrow \text{M10}$

$\emptyset > 30 - 38 \text{ mm} \rightarrow \text{M12}$

$\emptyset > 38 - 50 \text{ mm} \rightarrow \text{M16}$

$\emptyset > 50 - 85 \text{ mm} \rightarrow \text{M20}$

$\emptyset > 85 - 130 \text{ mm} \rightarrow \text{M24}$

$\emptyset > 130 \text{ mm} \rightarrow \text{M30}$

Keys: according to DIN 6885 (domed type)

Keyway width to ISO N9

Hollow shafts

Diameter tolerance:

$\emptyset \rightarrow \text{ISO H7}$ measured with plug gauge

Keys: according to DIN 6885 (domed type)

Exception: Key for WA.37 with shaft $\emptyset 25 \text{ mm}$ and for KA.29 with shaft $\emptyset 30 \text{ mm}$ according to DIN 6885-3 (low form)

Keyway width to ISO JS9

Multiple-spline shafts

D_m Measuring roller diameter

M_e Check size

Flanges

Centering shoulder tolerance:

$\varnothing \leq 230$ mm (flange sizes A120 – A300) → ISO j6

$\varnothing > 230$ mm (flange sizes A350 – A660) → ISO h6

Up to 3 different flange dimensions are available for each size of helical gear unit, SPIROPLAN® gear unit, AC (brake) motor and explosion-proof AC (brake) motor. The mountable flange for each size can be found in the respective dimension sheets.

7.3.3 Eyebolts, lifting eyes

R07 – R27 helical gear units, motors up to DR..100 and SPIROPLAN® gearmotors W..10 – W..30 are delivered without special transportation fixtures. All other gear units and motors are equipped with cast-on lifting eyes, screw-on lifting eyes or screw-on lifting eyebolts.

Gear unit/motor type	Screw-on		Cast-on Lifting eyes
	Eyebolts	Lifting eyes	
R..37 – R..57	—	X	—
R..67 – R..167	X	—	—
RX57 – RX67	—	X	—
RX77 – RX107	X	—	—
F..27 – F..157	—	—	X
K..19 – K..49	—	X	—
K..37 – K..157	—	—	X
K..167 – K..187	X	—	—
S..37 – S..47	—	X	—
S..57 – S..97	—	—	X
W..37 – W..47	—	X	—
\geq DR..112	X	—	—

Key: —not available, X available

7.3.4 Breather valves

The gear unit dimension drawings always show the screw plugs. The corresponding screw plug is replaced by an activated breather valve at the factory depending on the ordered mounting position M1 to M6. The result may be slightly altered contour dimensions.

20272545/EN – 11/2015

7 Important information on selection tables and dimension drawings

Dimension sheet information

7.3.5 Shrink disk connection

In order to non-positively transfer the torques stated in the catalog in case of gear units with hollow shaft and shrink disk connection, observe the following peripheral conditions in addition to the information on the respective dimension sheet when dimensioning the customer shaft:

- Surface roughness $R_z \leq 16 \mu\text{m}$
- Elastic limit of the customer shaft material R_e and/or $R_{p0.2} \geq 305 \text{ N/mm}^2$
- Design of the customer shaft as solid shaft

For customer shaft designs as hollow shaft, contact SEW-EURODRIVE.

7.3.6 Splined hollow shaft

FV.. hollow shaft gear unit sizes 27 to 107, and KV.. sizes 37 to 107 are supplied with splining according to standard 5480.

7.3.7 Rubber buffer for FA/FH/FV/FT

The depictions on the dimension sheets show the rubber buffers for FA/FH/FV/FT gear units in loose state. Preload rubber buffer by the indicated value ΔL . The characteristic curve of spring for the rubber buffer is available upon request from SEW-EURODRIVE.

7.3.8 Position of the torque arm

The following illustration shows the possible torque arm positions for helical-worm gear units, the 2-stage K..9 helical-bevel gear units, and SPIROPLAN® gear units (135 ° position not possible with SPIROPLAN® gear units) as well as the respective angles:

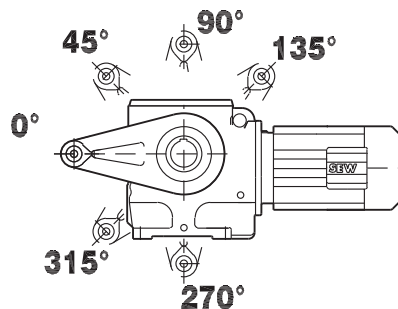

4982718475

For more information about torque arms, refer to the respective dimension sheets of the gearmotors:

Gearmotor	Dimension sheets on page
Helical-bevel gearmotors	(→ 298)
Helical-worm gearmotors	(→ 375)
SPIROPLAN® gearmotors	(→ 438)

20272545/EN – 11/2015

7.3.9 Dimension designations of motors

Following an overview of motor dimension designations:

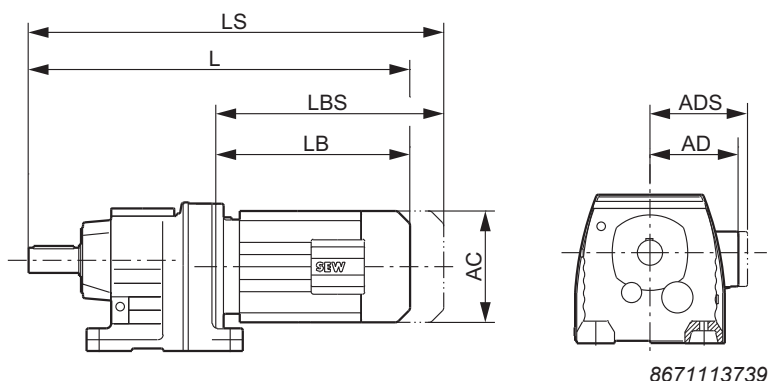

- L = Total length of the gearmotor
- LS = Total length of gearmotor including brake
- LB = Length of the motor
- LBS = Length of the brakemotor
- AC = Diameter of the motor
- AD = Distance between the center of the motor shaft and the top part of the terminal box
- ADS = Distance between the center of the brakemotor shaft and the top part of the terminal box

INFORMATION



Observe the changed AD and ADS dimensions. The spacer ring of the terminal box is not shown in the dimension drawings but you must consider the thickness of the spacer ring in the dimension details.

7.4 Gearmotor dimensions

7.4.1 Motor options

The motor dimensions may change when installing motor options. Refer to the dimension drawings of the motor options in the "AC Motors" catalog.

7.4.2 Special designs

The terminal box dimensions in special designs might vary from the standard.

7.4.3 EN 50347

European standard EN 50347 became effective in August 2001. This standard adopts the dimension designations for three-phase AC motors for sizes 56 to 315M and flange sizes 65 to 740 from the IEC 72-1 standard.

The new dimension designations specified in EN 50347/IEC 72-1 are used for the dimensions in question in the dimension tables of the dimensions sheets.

20272545/EN – 11/2015