

MASTERConnect

onlineordering.masterdrives.com



- Browse the product catalog
- Get real time price and availability
- Place orders
- Request literature
- View shipping details
- And much more!

For more information and to get your account set up contact us at:

888-922-8767 or email to
mconnect@masterdrives.com

The screenshot displays the MASTERConnect website interface. At the top, the logo 'MASTERConnect' is on the left, and 'MasterDrive 1-888-922-8767' is on the right. Below the logo, it states: 'All orders are submitted under your default warehouse (see "User Session")' and 'All orders are reviewed and re-confirmed by customer service prior to final release'. The main content area features a grid of product categories with images and descriptions:

- Sheaves**: Heavy Duty, Light Duty
- Bushings & Hubs**: OD Style, TB Style, DST Style, More...
- V-Belts**: FHP, Lawn & Garden Aramid, Classical, More...
- Couplings**
- Synchronous**
- Oil & Gas Products**

On the right side, there is a sidebar with a 'Live Item Add' form (Item Number, Quantity, Unit of Measure, Add to Cart), a 'My Account' section (Edit Account, Shipping Addresses, Order Pad, Part History, Saved Orders, Account Summary, Open Invoices, Paid Invoices, Open Transactions, Order History), and a 'Project Lists' section (TERRY, MTF 1, Default). The top right corner shows 'Welcome, MasterDrive, Inc. | English | Sign Out' and a shopping cart icon with '0 Items \$0.00 Checkout'.

MASTERSelect

Belt Drive Selection

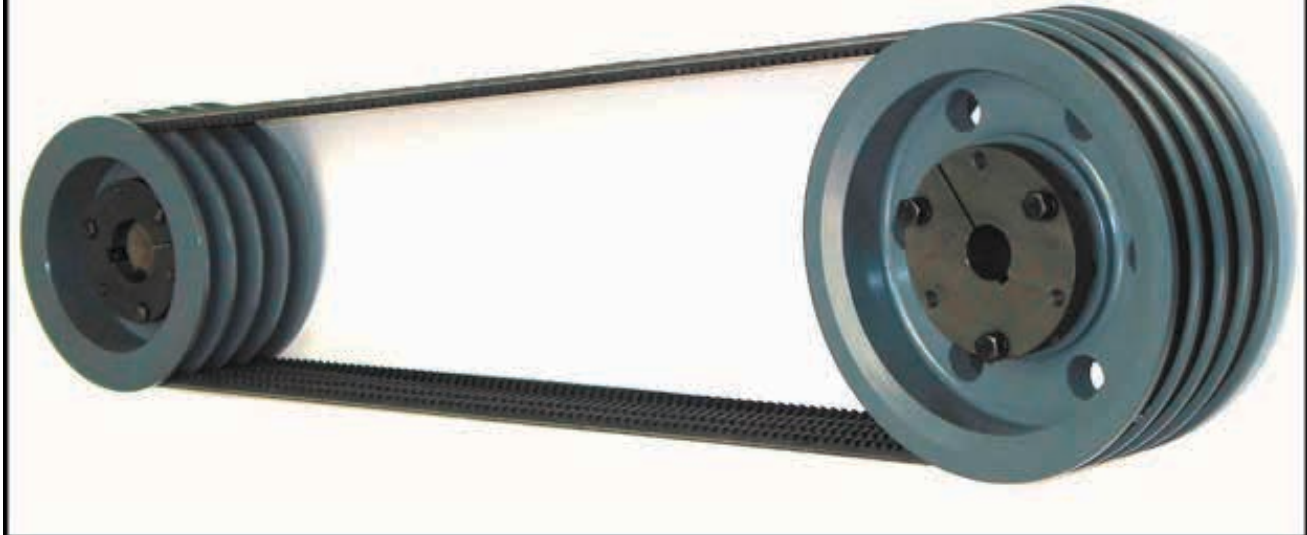

productselection.masterdrives.com

Our drive selection program allows you to quickly and easily determine what components you need to run your drive efficiently.

- Can be used by distributors or OEM's. Simply create an account on the home page and you're off!
- Input your specifications and get multiple drive options to choose from. It's just that easy!
- Use the advanced options to further customize your drive.

Questions? Email engineering@masterdrives.com

Table of Contents

Description	Page#
Sheave Nomenclature	2
Bored to Size Sheaves	3
Bore/Keyway Specifications	5
Step Pulleys	7
H & HR Bushing Sheaves	8
1VP, 2VP Variable Pitch Sheaves	13
1VL Variable Pitch Sheaves & AL Light Duty Sheaves	14
VL, VP Variable Pitch Installation Instructions	15
Light Duty Cross Reference Chart	16
Features/Benefits of H.D. Sheave & Bushing Combinations	18
A/B QD Bushing Sheaves	19
C QD Bushing Sheaves	24
3V QD Bushing Sheaves	29
5V QD Bushing Sheaves	33
8V QD Bushing Sheaves	37
Oilfield Sheaves	40
A/B DST Bushing Sheaves	41
A/B TB Bushing Sheaves	43
3V TB Bushing Sheaves	45
5V TB Bushing Sheaves	48
Flat Belt Pulleys	51
Timing Pulley Nomenclature	52
L Timing Pulleys	53
H Timing Pulleys	56
5M HTD Timing Pulleys	60
8M HTD Timing Pulleys	62
14M HTD Timing Pulleys	66
Metric Sheave Nomenclature	70
SPZ Metric Sheaves	71
SPA Metric Sheaves	74
SPB Metric Sheaves	77
SPC Metric Sheaves	81
QD Bushings	84
TB Bushings	87
Double Split Taper Bushings	89
MPB Bushings	91
Weld-On Hubs	92
BCS Couplings	93
Jaw Couplings	94
Jaw Coupling Selection	96
MD Flex Couplings ***NEW***	100
V-Belts	107
Timing Belt Nomenclature	126
Timing Belts	127
V-Belt Maintenance Tips	132
Product Specifications	134
Engineering Information	135

Note: All part numbers are generic and are used for identification purposes only.

A/B QD Sheaves

3B 124 SK

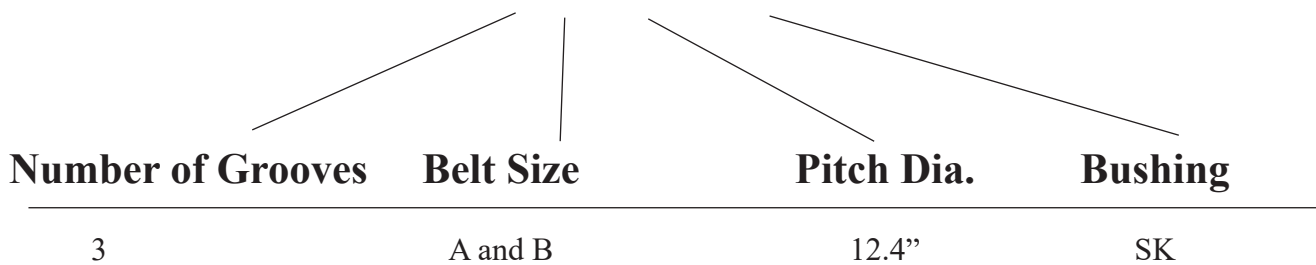

C QD Sheaves

8C 80 E

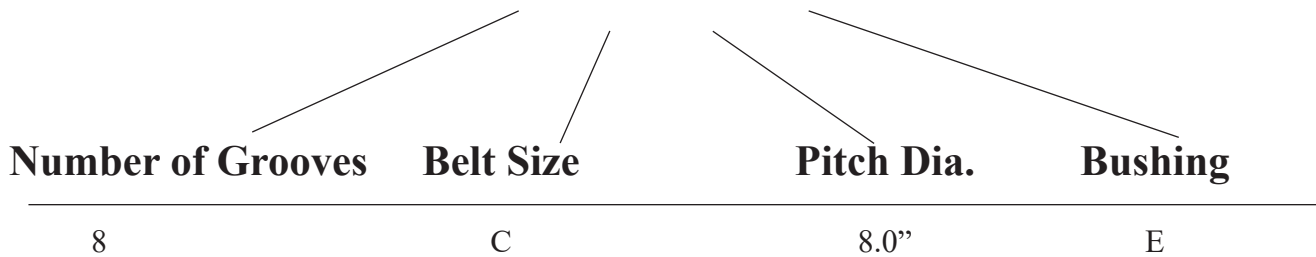

3V, 5V and 8V QD Sheaves

4/5V550SD

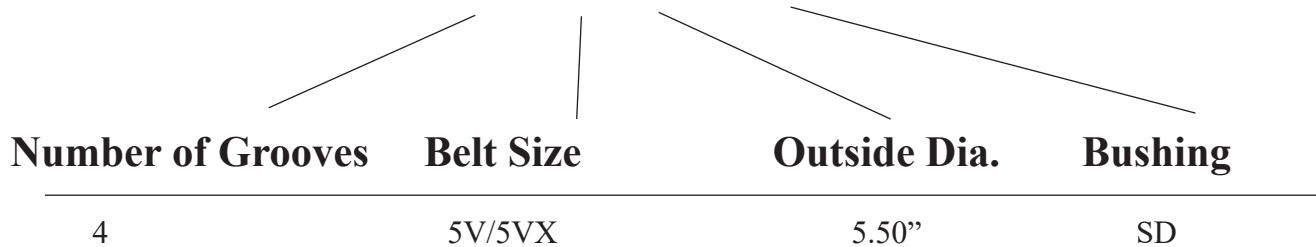

Cast Iron Sheaves - Light Duty
Bored-to Size- One Groove
AK17 to AK184

for 3L, 4L or A Belts. See pages 100-103.
Ordering part number size + bore
Example: AK20-1/2
AK39-1-1/8

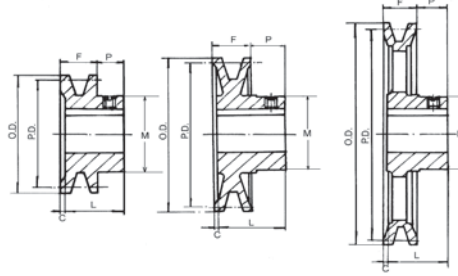

Type 1 Type 2 Type 3
s = solid, ● lh = lighting hole, ⊕ sp = spoked ⊗

AK

Part No.	Diameters			Type	Dimensions				Stock Bores Inch	Hub Dia M	Av. Wgt.
	O.D.	3L	4L or A		F	L	P	C			
AK17	1.75	1.16	1.50	1 s	21/32	15/16	7/16	5/32	1/2, 5/8	1.6	.40
AK20	2.00	1.46	1.80	1 s	21/32	15/16	7/16	5/32	1/2, 5/8, 3/4	1.6	.53
AK21	2.10	1.56	1.90	1 s	21/32	15/16	7/16	5/32	1/2, 5/8, 3/4	1.6	.57
AK22	2.20	1.66	2.00	1 s	21/32	15/16	7/16	5/32	1/2, 5/8, 3/4	1.6	.60
AK23	2.30	1.76	2.10	1 s	21/32	15/16	7/16	5/32	1/2, 5/8, 3/4, 7/8	1.6	.63
AK25	2.50	1.96	2.30	2 s	21/32	15/16	7/16	5/32	1/2, 5/8, 3/4, 7/8	1.6	.73
AK26	2.60	2.06	2.40	2 s	21/32	15/16	7/16	5/32	1/2, 5/8, 3/4, 7/8	1.6	.75
AK27	2.70	2.16	2.50	2 s	21/32	15/16	7/16	5/32	1/2, 5/8, 3/4, 7/8	1.6	.83
AK28	2.80	2.26	2.60	2 s	21/32	15/16	7/16	5/32	1/2, 5/8, 3/4, 7/8, 1	1.6	.84
AK30	3.05	2.46	2.80	2 s	21/32	15/16	7/16	5/32	1/2, 5/8, 3/4, 7/8, 1	1.6	.98
AK32	3.25	2.66	3.00	2 s	21/32	15/16	7/16	5/32	1/2, 5/8, 3/4, 7/8, 1	1.6	1.1
AK34	3.45	2.86	3.20	2 s	21/32	15/16	7/16	5/32	1/2, 5/8, 3/4, 7/8, 1	1.6	1.2
AK39	3.75	3.16	3.50	2 s	3/4	1 5/32	15/32	1/16	5/8, 3/4, 7/8, 15/16, 1, 1/2, 1 1/8	1.6	1.5
AK41	3.95	3.36	3.70	2 s	3/4	1 5/32	15/32	1/16	5/8, 3/4, 7/8, 15/16, 1, 1/2, 1 1/8	1.6	1.8
AK44	4.25	3.66	4.00	3 s	3/4	1 5/32	15/32	1/16	5/8, 3/4, 7/8, 15/16, 1, 1/2, 1 1/8	1.6	1.9
AK46	4.45	3.86	4.20	3 s	3/4	1 5/32	15/32	1/16	5/8, 3/4, 7/8, 15/16, 1, 1/2, 1 1/8	1.6	2.0
AK49	4.75	4.16	4.50	3 s	3/4	1 5/32	15/32	1/16	5/8, 3/4, 7/8, 15/16, 1, 1/2, 1 1/8	1.6	2.2
AK51	4.95	4.36	4.70	3 s	3/4	1 5/32	15/32	1/16	5/8, 3/4, 7/8, 1, 1/2, 1 1/8	1.6	2.4
AK54	5.25	4.66	5.00	3 s	3/4	1 5/32	15/32	1/16	5/8, 3/4, 7/8, 15/16, 1, 1/2, 1 1/8, 1 3/16	1.6	2.6
AK56	5.45	4.86	5.20	3 s	3/4	1 5/32	15/32	1/16	5/8, 3/4, 7/8, 15/16, 1, 1/2, 1 1/8, 1 3/16	1.6	2.7
AK59	5.75	5.16	5.50	3 s	3/4	1 5/32	15/32	1/16	5/8, 3/4, 7/8, 15/16, 1, 1/2, 1 1/8, 1 3/16	1.6	2.9
AK61	5.95	5.36	5.70	3 s	3/4	1 5/32	15/32	1/16	5/8, 3/4, 7/8, 15/16, 1, 1/2, 1 1/8, 1 3/16	1.6	3.2
AK64	6.25	5.66	6.00	3 lh	3/4	1 5/32	15/32	1/16	5/8, 3/4, 7/8, 15/16, 1, 1/2, 1 1/8, 1 3/16	1.6	3.0

Part No.	Diameters			Type	Dimensions				Stock Bores Inch	Hub Dia M	Av. Wgt.
	O.D.	3L	4L or A		F	L	P	C			
AK66	6.45	5.86	6.20	3 lh	3/4	1 5/32	15/32	1/16	5/8, 3/4, 1, 1 1/8	1.6	3.1
AK69	6.75	6.16	6.50	3 lh	3/4	1 15/32	23/32	0	3/4, 7/8, 1, 1 1/8	1.6	3.5
AK71	6.95	6.36	6.70	3 lh	3/4	1 15/32	23/32	0	5/8, 3/4, 7/8, 1, 1 1/8, 1 7/16	1.6	3.8
AK74	7.25	6.66	7.00	3 lh	3/4	1 15/32	23/32	0	5/8, 3/4, 15/16, 1, 1 1/8, 1 3/16, 1 1/4, 1/2, 1 7/16	1.6	4.2
AK79	7.75	7.16	7.50	3 lh	3/4	1 15/32	23/32	0	3/4, 1, 1 1/8, 1 7/16	1.6	4.5
AK84	8.25	7.66	8.00	3 lh	3/4	1 15/32	23/32	0	5/8, 3/4, 15/16, 1, 1 3/16, 1/2, 1 7/16	1.6	5.0
AK89	8.75	8.16	8.50	3 lh	3/4	1 15/32	23/32	0	3/4, 1, 1 1/8, 1 7/16	1.6	5.4
AK94	9.25	8.66	9.00	3 lh	3/4	1 15/32	23/32	0	5/8, 3/4, 15/16, 1, 1 3/16, 1 1/4, 1/2, 1 7/16	1.6	5.9
AK99	9.75	9.16	9.50	3 sp	3/4	1 15/32	23/32	0	3/4, 1, 1 7/16	1.7	6.1
AK104	10.25	9.66	10.00	3 sp	3/4	1 15/32	23/32	0	5/8, 3/4, 1, 1 3/16, 1 1/4, 1 3/8, 1 7/16	1.7	6.9
AK109	10.75	10.16	10.50	3 sp	3/4	1 15/32	23/32	0	3/4, 1, 1 3/8, 1 7/16	1.7	7.3
AK114	11.25	10.66	11.00	3 sp	3/4	1 15/32	23/32	0	3/4, 1, 1 3/16, 1 7/16	1.7	7.4
AK124	12.25	11.66	12.00	3 sp	3/4	1 15/32	23/32	0	5/8, 3/4, 7/8, 1, 1 3/16, 1 1/4, 1 7/16	1.7	8.3
AK134	13.25	12.66	13.00	3 sp	3/4	1 15/32	23/32	0	3/4, 1, 1 3/16, 1 3/8, 1 7/16	1.7	9.3
AK144	14.25	13.66	14.00	3 sp	3/4	1 15/32	23/32	0	3/4, 1, 1 3/16, 1 7/16	1.7	10.8
AK154	15.25	14.66	15.00	3 sp	3/4	1 15/32	23/32	0	3/4, 1, 1 3/16, 1 3/8, 1 7/16	1.7	12.6
AK184	18.25	17.66	18.00	3 sp	3/4	1 15/32	23/32	0	3/4, 1, 1 3/16, 1 7/16	1.7	17.1

Standard Key Dimensions	
Shaft Dia.	Keyseat W x D
1/2	None
5/8 - 7/8	3/16 x 3/32
15/16 - 1 1/4	1/4 x 1/8
1 5/16 - 1 3/8	5/16 x 5/32
1 7/16 - 1 3/4	3/8 x 3/16

AK Sheaves are accurately machined from gray cast iron, statically balanced, painted and individually packaged. They are furnished with standard keyway & 2 set screws. All set screws are 5/16-18 knurled. Recommended tightening torque is 110-130 inch-lbs.

Bored-To-Size Sheaves

Cast Iron Sheaves - **Light Duty**
 Bored-to Size, **Two Groove**
 2AK20 to 2AK184

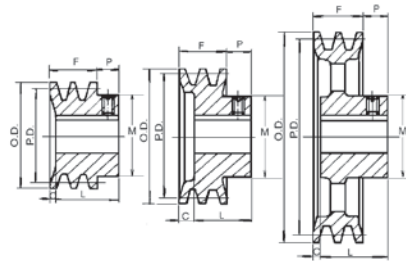

2AK

for **3L, 4L or A Belts**. See pages 100-103.

Order part number size + bore

Example: 2AK20-1/2

2AK39-1-1/8

Type 1

Type 2

Type 3

s = solid, ● lh = lighting hole, ⊗ sp = spoked

Part No.	Diameters			Type	Dimensions				Stock Bores in Inches	Hub Dia M	Series Average Weight
	O.D.	"3L" Pitch	"4L or A" Pitch		F	L	P	C			
2AK20	2.00	1.46	1.80	1 s	1 3/8	1 21/32	15/32	3/16	1/2, 5/8, 3/4, 7/8	1.6	.83
2AK21	2.15	1.56	1.90	1 s	1 3/8	1 21/32	15/32	3/16	1/2, 5/8, 3/4	1.6	.97
2AK22	2.25	1.66	2.00	1 s	1 3/8	1 21/32	15/32	3/16	1/2, 5/8, 3/4, 7/8	1.6	1.0
2AK23	2.35	1.76	2.10	1 s	1 3/8	1 21/32	15/32	3/16	5/8, 3/4, 7/8, 1	1.7	1.1
2AK25	2.55	1.96	2.30	1 s	1 3/8	1 21/32	15/32	3/16	5/8, 3/4, 7/8, 1	1.7	1.3
2AK26	2.65	2.06	2.40	1 s	1 3/8	1 21/32	15/32	3/16	5/8, 3/4, 7/8, 1	1.7	1.4
2AK27	2.75	2.16	2.50	1 s	1 3/8	1 21/32	15/32	3/16	5/8, 3/4, 7/8, 1	1.9	1.6
2AK28	2.85	2.26	2.60	1 s	1 3/8	1 21/32	15/32	3/16	5/8, 3/4, 7/8, 1	1.9	1.7
2AK30	3.05	2.46	2.80	1 s	1 3/8	1 21/32	15/32	3/16	1/2, 5/8, 3/4, 7/8, 1, 1 1/8	1.9	2.0
2AK32	3.25	2.66	3.00	1 s	1 3/8	1 21/32	15/32	3/16	1/2, 5/8, 3/4, 7/8, 1, 1 1/8	1.9	2.3
2AK34	3.45	2.86	3.20	1 s	1 3/8	1 21/32	15/32	3/16	1/2, 5/8, 3/4, 7/8, 1, 1 1/8	1.9	2.5
2AK39	3.75	3.16	3.50	2 s	1 3/8	1 11/32	15/32	1/2	1/2, 5/8, 3/4, 7/8, 1, 1 1/8	1.9	2.6
2AK41	3.95	3.36	3.70	2 s	1 3/8	1 11/32	15/32	1/2	5/8, 3/4, 7/8, 1, 1 1/8	1.9	2.8
2AK44	4.25	3.66	4.00	2 s	1 3/8	1 11/32	15/32	1/2	5/8, 3/4, 7/8, 1, 1 1/8	1.9	3.2
2AK46	4.45	3.86	4.20	2 s	1 3/8	1 11/32	15/32	1/2	7/8, 1, 1 1/8	1.6	2.9
2AK49	4.75	4.16	4.50	2 s	1 3/8	1 11/32	15/32	1/2	3/4, 7/8, 1, 1 1/8, 1 3/8	1.9	3.2
2AK51	4.95	4.36	4.70	2 s	1 3/8	1 11/32	15/32	1/2	3/4, 7/8, 1, 1 1/8, 1 3/8	1.6	3.4
2AK54	5.25	4.66	5.00	3 s	1 3/8	1 11/32	15/32	1/2	5/8, 3/4, 7/8, 1, 1 1/8, 1 3/8	1.6	3.7
2AK56	5.45	4.86	5.20	3 s	1 3/8	1 11/32	15/32	1/2	5/8, 3/4, 1, 1 1/8, 1 3/8	1.6	3.9
2AK59	5.75	5.16	5.50	3 s	1 3/8	1 11/32	15/32	1/2	1, 1 1/8, 1 3/8	1.9	4.4
2AK61	5.95	5.36	5.70	3 s	1 3/8	1 11/32	15/32	1/2	3/4, 7/8, 1, 1 1/8, 1 3/8	1.6	4.5
2AK64	6.25	5.66	6.00	3 s	1 3/8	1 19/32	11/32	1/8	3/4, 1, 1 1/8, 1 3/16, 1 3/8, 1 7/16	1.7	5.2
2AK74	7.25	6.66	7.00	3 lh	1 3/8	1 19/32	11/32	1/8	3/4, 1, 1 1/8, 1 3/16, 1 3/8, 1 7/16	1.7	6.0
2AK84	8.25	7.66	8.00	3 lh	1 3/8	1 19/32	11/32	1/8	3/4, 15/16, 1, 1 1/8, 1 3/16, 1 1/4, 1 3/8, 1 7/16	1.7	7.0
2AK94	9.25	8.66	9.00	3 lh	1 3/8	1 19/32	11/32	1/8	3/4, 1, 1 1/8, 1 3/16, 1 3/8, 1 7/16	1.7	8.2
2AK104	10.25	9.66	10.00	3 sp	1 3/8	1 19/32	11/32	1/8	3/4, 15/16, 1, 1 7/16	1.7	9.6
2AK114	11.25	10.66	11.00	3 sp	1 3/8	1 19/32	11/32	1/8	3/4, 1, 1 3/16, 1 3/8, 1 7/16	1.7	11.2
2AK124	12.25	11.66	12.00	3 sp	1 3/8	1 19/32	11/32	1/8	3/4, 1, 1 3/16, 1 7/16	1.7	12.1
2AK134	13.25	12.66	13.00	3 sp	1 3/8	1 19/32	11/32	1/8	1 3/16, 1 7/16	2.2	13.6
2AK144	14.25	13.66	14.00	3 sp	1 3/8	1 19/32	11/32	1/8	1, 1 7/16	1.7	14.6
2AK154	15.25	14.66	15.00	3 sp	1 3/8	1 19/32	11/32	1/8	1 3/16, 1 7/16	2.2	16.5
2AK184	18.25	17.66	18.00	3 sp	1 3/8	1 19/32	11/32	1/8	1 3/16, 1 7/16	2.2	22.7

Standard Key Dimensions	
Shaft Dia.	Keyseat W x D
1/2	None
5/8 - 7/8	3/16 x 3/32
15/16 - 1 1/4	1/4 x 1/8
1 5/16 - 1 3/8	5/16 x 5/32
1 7/16 - 1 3/4	3/8 x 3/16

2AK Sheaves are accurately machined from gray cast iron, statically balanced, painted and individually packaged. They are furnished with standard keyway & 2 set screws. All set screws are 5/16-18 knurled. Recommended tightening torque is 110-130 inch-lbs.

Cast Iron Sheaves - Light Duty
Bored-to Size, One Groove
BK24 to BK190
for 4L or A, 5L or B Belts. See pages
100-108

Order part number size + bore
Example: BK24-1/2

BK45-1-1/8

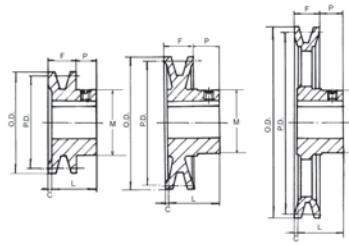

Type 1 Type 2 Type 3

s = solid, ● lh = lighting hole, ⊕ sp = spoked ⊗

Bored-To-Size Sheaves



BK

Part No.	Diameters			Type	Dimensions				Stock Bores in.	Hub Dia M	Series Av. Wgt.
	O.D.	4L or A	5L or B		F	L	P	C			
BK24	2.40	1.80	2.20	1 s	13/16	1 1/16	13/32	5/32	1/2, 5/8, 3/4, 7/8	1.6	.73
BK25	2.50	1.90	2.30	1 s	13/16	1 1/16	13/32	5/32	1/2, 5/8, 3/4, 7/8, 1	1.6	.74
BK26	2.60	2.00	2.40	1 s	13/16	1 1/16	13/32	5/32	1/2, 5/8, 3/4, 7/8	1.6	.80
BK27	2.70	2.10	2.50	2 s	13/16	1 1/16	13/32	5/32	1/2, 5/8, 3/4, 7/8, 1	1.6	.84
BK28	2.95	2.20	2.60	2 s	13/16	1 1/16	13/32	5/32	1/2, 5/8, 3/4, 7/8, 1, 1 1/8	1.6	1.0
BK30	3.15	2.40	2.80	2 s	13/16	1 1/16	13/32	5/32	1/2, 5/8, 3/4, 7/8, 1, 1 1/8	1.6	1.2
BK32	3.35	2.60	3.00	2 s	13/16	1 1/16	13/32	5/32	1/2, 5/8, 3/4, 7/8, 1, 1 1/8	1.6	1.2
BK34	3.55	2.80	3.20	2 s	7/8	1 5/32	13/32	1/8	1/2, 5/8, 3/4, 7/8, 1, 1 1/8	1.9	1.7
BK36	3.75	3.00	3.40	2 s	7/8	1 5/32	13/32	1/8	1/2, 5/8, 3/4, 7/8, 1, 1 1/8	1.9	1.9
BK40	3.95	3.20	3.60	2 s	7/8	1 5/32	13/32	1/8	1/2, 5/8, 3/4, 7/8, 1, 1 1/8	1.9	2.1
BK45	4.25	3.50	3.90	2 s	7/8	1 5/32	13/32	1/8	5/8, 3/4, 7/8, 1, 1 1/8	1.7	2.1
BK47	4.45	3.70	4.10	2 s	7/8	1 5/32	13/32	1/8	5/8, 3/4, 7/8, 1, 1 1/8	1.6	2.2
BK50	4.75	4.00	4.40	3 s	7/8	1 5/32	13/32	1/8	5/8, 3/4, 7/8, 1, 1 1/8	1.6	2.5
BK52	4.95	4.20	4.60	3 s	7/8	1 5/32	13/32	1/8	5/8, 3/4, 7/8, 1, 1 1/8	1.6	2.6
BK55	5.25	4.50	4.90	3 s	7/8	1 5/32	13/32	1/8	5/8, 3/4, 7/8, 1, 1 1/8	1.6	3.0
BK57	5.45	4.70	5.10	3 s	7/8	1 5/32	13/32	1/8	5/8, 3/4, 7/8, 15/16, 1, 1 1/8, 1 3/16	1.6	3.1
BK60	5.75	5.00	5.40	3 s	7/8	1 5/32	13/32	1/8	5/8, 3/4, 7/8, 1, 1 1/8, 1 3/16	1.6	3.4
BK62	5.95	5.20	5.60	3 s	7/8	1 5/32	13/32	1/8	5/8, 3/4, 7/8, 15/16, 1, 1 1/8, 1 3/16	1.6	3.6
BK65	6.25	5.50	5.90	3 s	7/8	1 5/32	13/32	1/8	5/8, 3/4, 1, 1 1/8	1.6	3.9
BK67	6.45	5.70	6.10	3 lh	7/8	1 5/32	13/32	1/8	5/8, 3/4, 1, 1 1/8, 1 3/16	1.6	3.7
BK70	6.75	6.00	6.40	3 s	7/8	1 15/32	21/32	1/16	5/8, 3/4, 7/8, 15/16, 1, 1 1/8, 1 3/16	1.6	4.6
BK72	6.95	6.20	6.60	3 lh	7/8	1 15/32	21/32	1/16	3/4, 1, 1 1/8, 1 3/8	1.6	4.4

Part No.	Diameters			Type	Dimensions				Dia Stock Bores in.	Hub M	Series Average Weight
	O.D.	4L or A	5L or B		F	L	P	C			
BK75	7.25	6.50	6.90	3 lh	7/8	1 15/32	21/32	1/16	3/4, 1, 1 1/8, 1 3/8	1.6	4.6
BK77	7.45	6.70	7.10	3 lh	7/8	1 15/32	21/32	1/16	3/4, 1, 1 1/8, 1 3/8	1.6	5.1
BK80	7.75	7.00	7.40	3 lh	7/8	1 15/32	21/32	1/16	5/8, 3/4, 7/8, 1, 1 1/8, 1 3/16, 1 1/4, 1 3/8, 1 7/16	1.6	5.4
BK85	8.25	7.50	7.90	3 lh	7/8	1 15/32	21/32	1/16	3/4, 1, 1 1/8, 1 3/8, 1 7/16	1.6	5.8
BK90	8.75	8.00	8.40	3 lh	7/8	1 15/32	21/32	1/16	3/4, 7/8, 15/16, 1, 1 1/8, 1 3/16, 1 3/8, 1 7/16	1.6	6.1
BK95	9.25	8.50	8.90	3 lh	7/8	1 15/32	21/32	1/16	3/4, 1, 1 1/8, 1 3/8	1.6	7.0
BK100	9.75	9.00	9.40	3 lh	7/8	1 15/32	21/32	1/16	3/4, 7/8, 15/16, 1, 1 1/8, 1 3/16, 1 1/4, 1 3/8, 1 7/16	1.6	7.4
BK105	10.25	9.50	9.90	3 lh	7/8	1 15/32	21/32	1/16	1, 1 3/8, 1 7/16	1.7	8.0
BK110	10.75	10.00	10.40	3 sp	7/8	1 15/32	21/32	1/16	3/4, 1, 1 1/8, 1 3/16, 1 3/8, 1 7/16	1.7	8.5
BK115	11.25	10.50	10.90	3 sp	7/8	1 15/32	21/32	1/16	1, 1 7/16	1.7	8.9
BK120	11.75	11.00	11.40	3 sp	7/8	1 15/32	21/32	1/16	3/4, 1, 1 3/16, 1 7/16	1.7	10.0
BK130	12.75	12.00	12.40	3 sp	7/8	1 15/32	21/32	1/16	3/4, 1, 1 1/8, 1 3/16, 1 1/4, 1 7/16	1.7	10.8
BK140	13.75	13.00	13.40	3 sp	7/8	1 15/32	21/32	1/16	3/4, 1, 1 3/16, 1 7/16	1.7	12.1
BK160	15.75	15.00	15.40	3 sp	7/8	1 15/32	21/32	1/16	1, 1 1/8, 1 3/16, 1 1/4, 1 7/16	1.7	14.4
BK190	18.75	18.00	18.40	3 sp	7/8	1 15/32	21/32	1/16	1, 1 3/16, 1 1/4, 1 7/16	1.7	21.3

MasterDrive Bore/Keyway Specifications

Bore Size Nominal	Bore Size Nominal	G8 Tolerance		Key Tolerances Key Width Range		
Dimension (mm)	Dimension (inches)	(mm)	(inches)	>	<	inches
6-10	.2362-.3937	High Low	+0.027 mm +.005 mm	High Low	+0.0010" +.0001"	* * 1/2" +.002"
10-18	.3937-.7087	High Low	+0.033 mm +.006 mm	High Low	+0.0013" +.0002"	* * 3/4" 1" +.003"
18-30	.7087-1.1811	High Low	+0.040mm +.007mm	High Low	+0.0016" +.0003"	* * 1" 1 1/2" +.004"
30-50	1.1811-1.9685	High Low	+0.048mm +.009mm	High Low	+0.0019" +.0003"	* * *
50-80	1.9685-3.1496	High Low	+0.056mm +.010mm	High Low	+0.0022" +.0003"	* * *
80-120	3.1496-4.7244	High Low	+0.066mm +.012mm	High Low	+0.0026" +.0004"	* * *
120-180	4.7244-7.0866	High Low	+0.077mm +.014mm	High Low	+0.0030" +.0005"	* * *
180-250	7.0866-9.8425	High Low	+0.087mm +.015mm	High Low	+0.0034" +.0005"	* * *

Standard Key Dimensions	
Shaft Dia.	Keyseat W x D
1/2	None
5/8 - 7/8	3/16 x 3/32
15/16 - 1 1/4	1/4 x 1/8
1 5/16 - 1 3/8	5/16 x 5/32
1 7/16 - 1 3/4	3/8 x 3/16

BK Sheaves are accurately machined from gray cast iron, statically balanced, painted and individually packaged. They are furnished with standard keyway & 2 set screws. All set screws are 5/16-18 knurled. Recommended tightening torque is 110-130 inch-lbs.

Bored-To-Size Sheaves

Cast Iron Sheaves - Light Duty
 Bored-to Size, Two Groove
 2BK25 to 2BK190
 for 4L or A, 5L or B Belts. See pages
 100-108

Order part number size + bore

Example: 2BK25-1/2

2BK47-1-1/8

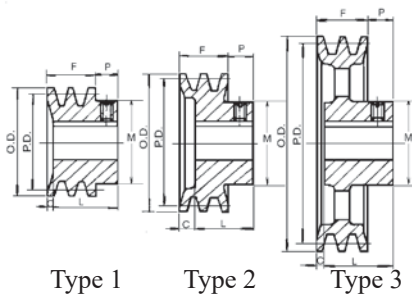

Type 1 Type 2 Type 3

s = solid, ● lh = lighting hole, ⊙ sp = spoked ⊗

MASTERDRIVE
 POWER TRANSMISSION PRODUCTS



2BK

Part No.	Diameters			Type	Dimensions				Stock Bores in Inches	Hub Dia M	Series Average Weight
	O.D.	Pitch			F	L	P	C			
		"4L or A"	"5L or B"								
2BK25	2.50	1.90	2.30	1 s	1 3/4	1 31/32	15/32	1/4	1/2, 5/8, 3/4, 7/8	1.6	1.5
2BK27	2.70	2.10	2.50	1 s	1 3/4	1 31/32	15/32	1/4	1/2, 5/8, 3/4, 7/8, 1, 1 1/8	1.7	1.7
2BK28	2.95	2.20	2.60	1 s	1 3/4	1 31/32	15/32	1/4	1/2, 5/8, 3/4, 7/8, 1, 1 1/8	1.9	2.1
2BK30	3.15	2.40	2.80	1 s	1 3/4	1 31/32	15/32	1/4	1/2, 5/8, 3/4, 7/8, 1, 1 1/8, 1 3/8	1.9	2.3
2BK32	3.35	2.60	3.00	1 s	1 3/4	1 31/32	15/32	1/4	5/8, 3/4, 7/8, 1, 1 1/8	1.6	2.7
2BK34	3.55	2.80	3.20	1 s	1 3/4	1 31/32	15/32	1/4	5/8, 3/4, 7/8, 1, 1 1/8	1.6	3.1
2BK36	3.75	3.00	3.40	1 s	1 3/4	1 31/32	15/32	1/4	5/8, 3/4, 7/8, 1, 1 1/8	1.6	3.4
2BK40	3.95	3.20	3.60	2 s	1 3/4	1 15/32	15/32	3/4	5/8, 3/4, 7/8, 1, 1 1/8	1.6	3.4
2BK45	4.25	3.50	3.90	2 s	1 3/4	1 15/32	15/32	3/4	1, 1 1/8, 1 3/8	1.9	4.0
2BK47	4.45	3.70	4.10	2 s	1 3/4	1 15/32	15/32	3/4	7/8, 1, 1 1/8, 1 3/8	1.6	4.2
2BK50	4.75	4.00	4.40	2 s	1 3/4	1 15/32	15/32	3/4	3/4, 1, 1 1/8, 1 3/8	1.6	4.8
2BK52	4.95	4.20	4.60	2 s	1 3/4	1 15/32	15/32	3/4	5/8, 7/8, 1, 1 1/8, 1 3/8	1.6	5.2
2BK55	5.25	4.50	4.90	2 s	1 3/4	1 15/32	15/32	3/4	1 1/8, 1 3/8, 1 7/8	1.9	5.8
2BK57	5.45	4.70	5.10	2 s	1 3/4	1 15/32	15/32	3/4	1, 1 1/8, 1 3/8	1.9	5.4
2BK60	5.75	5.00	5.40	3 s	1 3/4	1 15/32	15/32	3/4	3/4, 7/8, 1, 1 1/8, 1 3/8	1.6	5.7
2BK62	5.95	5.20	5.60	3 s	1 3/4	1 15/32	15/32	3/4	1, 1 1/8, 1 3/8	1.9	6.0
2BK65	6.25	5.50	5.90	3 s	1 3/4	1 15/32	15/32	3/4	1, 1 1/8, 1 3/8	1.9	6.5
2BK67	6.45	5.70	6.10	3 s	1 3/4	1 15/32	15/32	3/4	1, 1 1/8, 1 3/8	1.9	6.8
2BK70	6.75	6.00	6.40	3 s	1 3/4	1 19/32	11/32	1/2	3/4, 1, 1 1/8, 1 3/16, 1 7/16	1.6	7.6
2BK80	7.75	7.00	7.40	3 lh	1 3/4	1 19/32	11/32	1/2	3/4, 1, 1 1/8, 1 3/16, 1 1/4, 1 3/8, 1 7/16	1.6	8.7
2BK90	8.75	8.00	8.40	3 lh	1 3/4	1 19/32	11/32	1/2	3/4, 1, 1 1/8, 1 3/16, 1 7/16	1.6	10.0
2BK100	9.75	9.00	9.40	3 lh	1 3/4	1 19/32	11/32	1/2	3/4, 1, 1 1/8, 1 3/16, 1 7/16	1.6	11.8
2BK110	10.75	10.00	10.40	3 sp	1 3/4	1 19/32	11/32	1/2	1, 1 3/16, 1 3/8, 1 7/16	1.7	14.0
2BK120	11.75	11.00	11.40	3 sp	1 3/4	1 19/32	11/32	1/2	1, 1 3/16, 1 7/16	1.7	15.6
2BK130	12.75	12.00	12.40	3 sp	1 3/4	1 19/32	11/32	1/2	1, 1 3/16, 1 7/16	1.7	17.0
2BK140	13.75	13.00	13.40	3 sp	1 3/4	1 19/32	11/32	1/2	1, 1 3/16, 1 7/16	1.7	19.0
2BK160	15.75	15.00	15.40	3 sp	1 3/4	1 19/32	11/32	1/2	1, 1 3/16, 1 7/16	1.7	23.7
2BK190	18.75	18.00	18.40	3 sp	1 3/4	1 19/32	11/32	1/2	1 3/16, 1 1/4, 1 7/16	2.2	30.3

6 2BK Sheaves are accurately machined from gray cast iron, statically balanced, painted and individually packaged. They are furnished with standard keyway & 2 set screws. All set screws are 5/16-18 knurled. Recommended tightening torque is 110-130 inch-lbs.

Cast Iron Sheaves - **Light Duty**
Bored-to Size
for 3L, 4L or A Belts.
See pages 100-103

Order part number size + bore
Example: AKS42-1/2

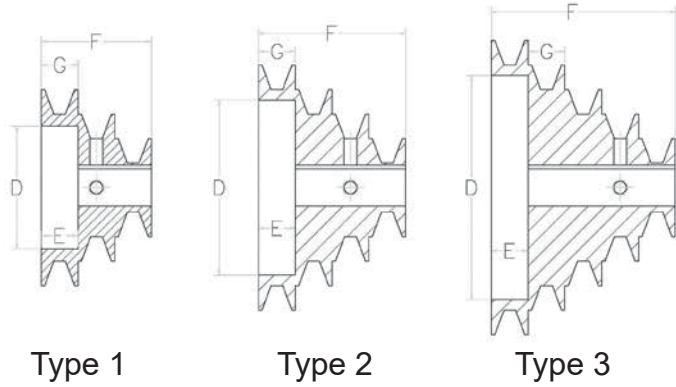

Part No.	Type	Outside Diameters	Stock Bores	Dimensions (Inches)				Wt.
				D	G	F	E	
AKS62	3	6" 5" 4" 3" 2"	1/2-5/8-3/4-7/8	4 9/16	3/4	3 3/4	3/4	8.0
AKS63	2	6" 5" 4" 3"	1/2-5/8-3/4-7/8-1-1 1/8	4 9/16	3/4	3	3/4	7.5
AKS64	1	6" 5" 4"	1/2-5/8-3/4-7/8-1-1 1/8	4 9/16	3/4	2 1/4	3/4	6.5
AKS52	2	5" 4" 3" 2"	1/2-5/8-3/4-7/8	3 9/16	3/4	3	3/4	4.5
AKS53	1	5" 4" 3"	1/2-5/8-3/4-7/8-1-1 1/8	3 9/16	3/4	2 1/4	3/4	4.2
AKS42	1	4" 3" 2"	1/2-5/8-3/4-7/8	2 1/2	3/4	2 1/4	3/4	2.3

Standard Key Dimensions	
Shaft Dia.	Keyseat W x D
1/2	None
5/8 - 7/8	3/16 x 3/32
15/16 - 1 1/4	1/4 x 1/8

Step pulleys are accurately machined from gray cast iron, statically balanced, painted and individually packaged. They are furnished with standard keyway & 2 set screws. All set screws are 5/16-18 knurled. Recommended tightening torque is 110-130 inch-lbs.

H Bushing Sheaves

Cast Iron Sheaves - **Light-Duty Bushed, One Groove and Two Groove**

AK30H to AK184H -
2AK30H to 2AK184H

Order part number size

Example: AK30H

Example: 2AK32H

for 3L, 4L or A Belts. See pages 100-103.

Order H bushing separately

**For All
1 Groove Sheaves**

F= 3/4
L= 1 1/4
G= 7/16
E= 3/16



AKH

**For All
2 Groove Sheaves**

F= 1 3/8
L= 1 1/4
X= 7/8
G= 1/2
E= 3/16



2AKH

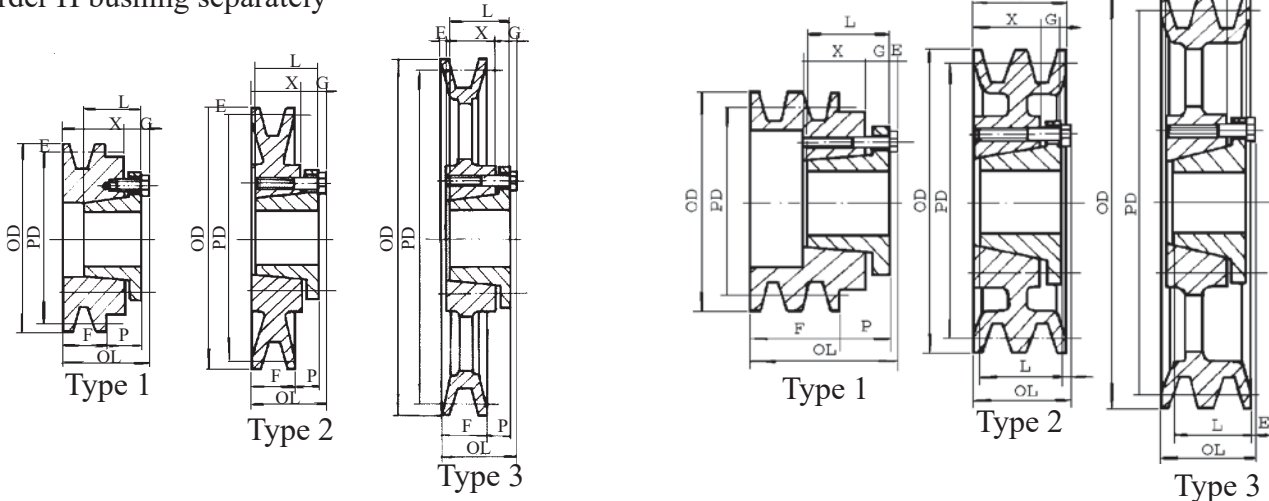

s = solid, ● lh = lighting hole, ⊙ sp = spoked ⊗

Part No.	Diameters			Type	Dimensions			
	O.D.	Pitch			O.L.	P	X	WT.
		"3L"	"4L or A"					
AK30H	3.05	2.46	2.80	1 s	1 13/16	7/8	1 3/16	1.30
AK32H	3.30	2.66	3.00	1 s	1 13/16	7/8	1 3/16	1.30
AK34H	3.45	2.86	3.20	2 s	1 1/2	9/16	7/8	1.20
AK39H	3.75	3.16	3.50	2 s	1 1/2	9/16	7/8	1.50
AK41H	3.95	3.36	3.70	2 s	1 1/2	9/16	7/8	1.80
AK44H	4.25	3.66	4.00	2 s	1 1/2	9/16	7/8	2.00
AK46H	4.45	3.86	4.20	2 s	1 1/2	9/16	7/8	2.30
AK49H	4.75	4.16	4.50	2 s	1 1/2	9/16	7/8	2.60
AK51H	4.95	4.36	4.70	2 s	1 1/2	9/16	7/8	2.70
AK54H	5.25	4.66	5.00	2 s	1 1/2	9/16	7/8	2.60
AK56H	5.45	4.86	5.20	2 s	1 1/2	9/16	7/8	2.80
AK59H	5.75	5.16	5.50	2 s	1 1/2	9/16	7/8	3.00
AK61H	5.95	5.36	5.70	3 s	1 1/2	9/16	7/8	3.10
AK64H	6.25	5.66	6.00	3 s	1 1/2	9/16	7/8	3.30
AK66H	6.45	5.86	6.20	3 s	1 1/2	9/16	7/8	3.60
AK69H	6.75	6.16	6.50	3 lh	1 1/2	9/16	7/8	3.50
AK71H	6.95	6.36	6.70	3 lh	1 1/2	9/16	7/8	3.50
AK74H	7.25	6.66	7.00	3 lh	1 1/2	9/16	7/8	3.80
AK79H	7.75	7.16	7.50	3 lh	1 1/2	9/16	7/8	4.20
AK84H	8.25	7.66	8.00	3 lh	1 1/2	9/16	7/8	4.60
AK89H	8.75	8.16	8.50	3 lh	1 1/2	9/16	7/8	4.80
AK94H	9.25	8.66	9.00	3 lh	1 1/2	9/16	7/8	5.60
AK99H	9.75	9.16	9.50	3 lh	1 1/2	9/16	7/8	5.90
AK104H	10.25	9.66	10.00	3 sp	1 1/2	9/16	7/8	6.80
AK109H	10.75	10.16	10.50	3 sp	1 1/2	9/16	7/8	7.10
AK114H	11.25	10.66	11.00	3 sp	1 1/2	9/16	7/8	7.50
AK124H	12.25	11.66	12.00	3 sp	1 1/2	9/16	7/8	8.00
AK134H	13.25	12.66	13.00	3 sp	1 1/2	9/16	7/8	10.70
AK144H	14.25	13.66	14.00	3 sp	1 1/2	9/16	7/8	11.10
AK154H	15.25	14.66	15.00	3 sp	1 1/2	9/16	7/8	12.50
AK184H	18.25	17.66	18.00	3 sp	1 1/2	9/16	7/8	17.30

Part No.	Diameters			Type	Dimensions			
	O.D.	Pitch			O.L.	P	X	WT.
		"3L"	"4L or A"					
2AK30H	3.05	2.46	2.80	1 s	2 7/16	7/8	15/16	1.70
2AK32H	3.25	2.66	3.00	1 s	2 7/16	7/8	15/16	1.80
2AK34H	3.45	2.86	3.20	1 s	2	7/16	1/2	1.70
2AK39H	3.75	3.16	3.50	1 s	2	7/16	1/2	2.10
2AK41H	3.95	3.36	3.70	2 s	1 1/2	1/16	-	2.40
2AK44H	4.25	3.66	4.00	2 s	1 1/2	1/16	-	2.90
2AK46H	4.45	3.86	4.20	2 s	1 1/2	1/16	-	3.20
2AK49H	4.75	4.16	4.50	2 s	1 1/2	1/16	-	3.70
2AK51H	4.95	4.36	4.70	2 s	1 1/2	1/16	-	3.20
2AK54H	5.25	4.66	5.00	2 s	1 1/2	1/16	-	3.50
2AK56H	5.45	4.86	5.20	2 s	1 1/2	1/16	-	3.80
2AK59H	5.75	5.16	5.50	3 s	1 1/2	1/16	-	4.10
2AK61H	5.95	5.36	5.70	3 s	1 1/2	1/16	-	4.30
2AK64H	6.25	5.66	6.00	3 s	1 1/2	1/16	-	4.60
2AK74H	7.25	6.66	7.00	3 lh	1 1/2	1/16	-	5.10
2AK84H	8.25	7.66	8.00	3 lh	1 1/2	1/16	-	6.10
2AK94H	9.25	8.66	9.00	3 lh	1 1/2	1/16	-	7.40
2AK104H	10.25	9.66	10.00	3 sp	1 1/2	1/16	-	9.20
2AK114H	11.25	10.66	11.00	3 sp	1 1/2	1/16	-	10.00
2AK124H	12.25	11.66	12.00	3 sp	1 1/2	1/16	-	10.90
2AK134H	13.25	12.66	13.00	3 sp	1 1/2	1/16	-	13.10
2AK144H	14.25	13.66	14.00	3 sp	1 1/2	1/16	-	14.60
2AK154H	15.25	14.66	15.00	3 sp	1 1/2	1/16	-	16.20
2AK184H	18.25	17.66	18.00	3 sp	1 1/2	1/16	-	21.60

Stock H Bushings and Metric bores on pages 89-90.

AK Sheaves are accurately machined from gray cast iron, statically balanced, painted and individually packaged.

Note: Cast iron sheaves may not exceed 6500 FPM. This speed **DOES NOT** specify if dynamic balancing (2 plane) is required. Contact customer service to verify whether dynamic balancing is required.

Cast Iron Sheaves - **Light Duty**
Bushed, **One Groove and Two Groove**
BK30H to BK190H - 2BK32H to 2BK190H

Order part number size

Example: BK30H

Example: 2BK32H

for 4L or A, 5L or B Belts.

See pages 100-108.

Order H bushings separately

**For All
1 Groove Sheaves**
F= 7/8
L= 1 1/4
G= 7/16
E= 3/16



BKH

**For All
2 Groove
Sheaves**

F= 1 3/4
L= 1 1/4
X= 7/8
G= 7/16
E= 3/16



2BKH

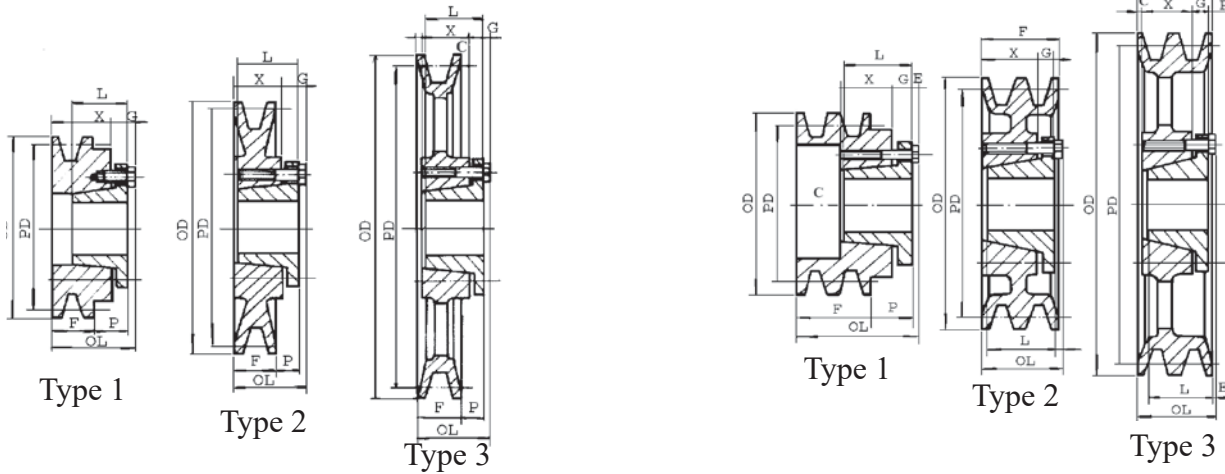

s = solid, ● lh = lighting hole, ⊙ sp = spoked ⊗

Part No.	Diameters			Type	Dimensions				WT.
	O.D.	Pitch "4L or A" "5L or B"			O.L.	P	C	X	
BK30H	3.15	2.40	2.80	1 s	1 15/16	7/8	-	1 3/8	1.4
BK32H	3.35	2.60	3.00	1 s	1 15/16	7/8	-	1 3/8	1.6
BK34H	3.55	2.80	3.20	1 s	1 15/16	7/8	-	1 3/8	1.8
BK36H	3.75	3.00	3.40	2 s	1 1/2	7/16	-	7/8	1.5
BK40H	3.95	3.20	3.60	2 s	1 1/2	7/16	-	7/8	1.7
BK45H	4.25	3.50	3.90	2 s	1 1/2	7/16	-	7/8	2.1
BK47H	4.45	3.70	4.10	2 s	1 1/2	7/16	-	7/8	2.3
BK50H	4.75	4.00	4.40	2 s	1 1/2	7/16	-	7/8	2.7
BK52H	4.95	4.20	4.60	2 s	1 1/2	7/16	-	7/8	3.0
BK55H	5.25	4.50	4.90	2 s	1 1/2	7/16	-	7/8	3.5
BK57H	5.45	4.70	5.10	2 s	1 1/2	7/16	-	7/8	3.6
BK60H	5.75	5.00	5.40	2 s	1 1/2	7/16	-	7/8	3.5
BK62H	5.95	5.20	5.60	2 s	1 1/2	7/16	-	7/8	3.7
BK65H	6.25	5.50	5.90	2 s	1 1/2	7/16	-	7/8	4.0
BK67H	6.45	5.70	6.10	2 s	1 1/2	7/16	-	7/8	4.0
BK70H	6.75	6.00	6.40	3 s	1 9/16	1/2	1/16	7/8	4.7
BK72H	6.95	6.20	6.60	3 s	1 9/16	1/2	1/16	7/8	4.7
BK75H	7.25	6.50	6.90	3 lh	1 9/16	1/2	1/16	7/8	4.7
BK77H	7.45	6.70	7.10	3 lh	1 9/16	1/2	1/16	7/8	4.8
BK80H	7.75	7.00	7.40	3 lh	1 9/16	1/2	1/16	7/8	5.3
BK85H	8.25	7.50	7.90	3 lh	1 9/16	1/2	1/16	7/8	5.5
BK90H	8.75	8.00	8.40	3 lh	1 9/16	1/2	1/16	7/8	6.0
BK95H	9.25	8.50	8.90	3 lh	1 9/16	1/2	1/16	7/8	6.7
BK100H	9.75	9.00	9.40	3 lh	1 9/16	1/2	1/16	7/8	7.1
BK105H	10.25	9.50	9.90	3 lh	1 9/16	1/2	1/16	7/8	7.5
BK110H	10.75	10.00	10.40	3 sp	1 9/16	1/2	1/16	7/8	8.6
BK115H	11.25	10.50	10.90	3 sp	1 9/16	1/2	1/16	7/8	8.8
BK120H	11.75	11.00	11.40	3 sp	1 9/16	1/2	1/16	7/8	9.2
BK130H	12.75	12.00	12.40	3 sp	1 9/16	1/2	1/16	7/8	10.6
BK140H	13.75	13.00	13.40	3 sp	1 9/16	1/2	1/16	7/8	12.9
BK150H	14.75	14.00	14.40	3 sp	1 9/16	1/2	1/16	7/8	14.4
BK160H	15.75	15.00	15.40	3 sp	1 9/16	1/2	1/16	7/8	15.5
BK190H	18.75	18.00	18.40	3 sp	1 9/16	1/2	1/16	7/8	21.1

Part No.	Diameters			Type	Dimensions				WT.
	O.D.	Pitch "4L or A" "5L or B" Type			O.L.	P	C	X	
2BK32H	3.35	2.60	3.00	1 s	2 13/16	7/8	1 5/16	2.5	
2BK34H	3.55	2.80	3.20	1 s	2 13/16	7/8	1 5/16	2.8	
2BK36H	3.75	3.00	3.40	1 s	2 3/8	7/16	7/8	2.6	
2BK40H	3.95	3.20	3.60	1 s	2 3/8	7/16	7/8	3.0	
2BK45H	4.25	3.50	3.90	1 s	2 3/8	7/16	7/8	3.4	
2BK47H	4.45	3.70	4.10	2 s	1 3/4	7/16	-	3.8	
2BK50H	4.75	4.00	4.40	2 s	1 3/4	7/16	-	4.4	
2BK52H	4.95	4.20	4.60	2 s	1 3/4	7/16	-	4.8	
2BK55H	5.25	4.50	4.90	2 s	1 3/4	7/16	-	5.4	
2BK57H	5.45	4.70	5.10	2 s	1 3/4	7/16	-	5.3	
2BK60H	5.75	5.00	5.40	2 s	1 3/4	7/16	-	5.6	
2BK62H	5.95	5.20	5.60	2 s	1 3/4	7/16	-	5.8	
2BK65H	6.25	5.50	5.90	3 s	1 3/4	7/16	1/4	6.4	
2BK67H	6.45	5.70	6.10	3 s	1 3/4	7/16	1/4	6.7	
2BK70H	6.75	6.00	6.40	3 s	1 3/4	7/16	1/4	7.2	
2BK80H	7.75	7.00	7.40	3 lh	1 3/4	7/16	1/4	8.3	
2BK90H	8.75	8.00	8.40	3 lh	1 3/4	7/16	1/4	9.8	
2BK100H	9.75	9.00	9.40	3 lh	1 3/4	7/16	1/4	11.5	
2BK110H	10.75	10.00	10.40	3 sp	1 3/4	7/16	1/4	13.6	
2BK120H	11.75	11.00	11.40	3 sp	1 3/4	7/16	1/4	15.0	
2BK130H	12.75	12.00	12.40	3 sp	1 3/4	7/16	1/4	16.7	
2BK140H	13.75	13.00	13.40	3 sp	1 3/4	7/16	1/4	19.8	
2BK160H	15.75	15.00	15.40	3 sp	1 3/4	7/16	1/4	24.5	
2BK190H	18.75	18.00	18.40	3 sp	1 3/4	7/16	1/4	26.0	

Stock H Bushings and Metric bores on pages 89-90.

BK Sheaves are accurately machined from gray cast iron, statically balanced, painted and individually packaged.

Note: Cast iron sheaves may not exceed 6500 FPM. This speed **DOES NOT** specify if dynamic balancing (2 plane) is required. Contact customer service to verify whether dynamic balancing is required.

3BKH Sheaves

Cast Iron Sheaves - **Light Duty**
Bushed, **Three Groove**
3BK45H to 3BK190H
Order part number size
Example: 3BK45H



for **4L or A, 5L or B Belts.**
See pages **100-108.**
Order H bushings separately

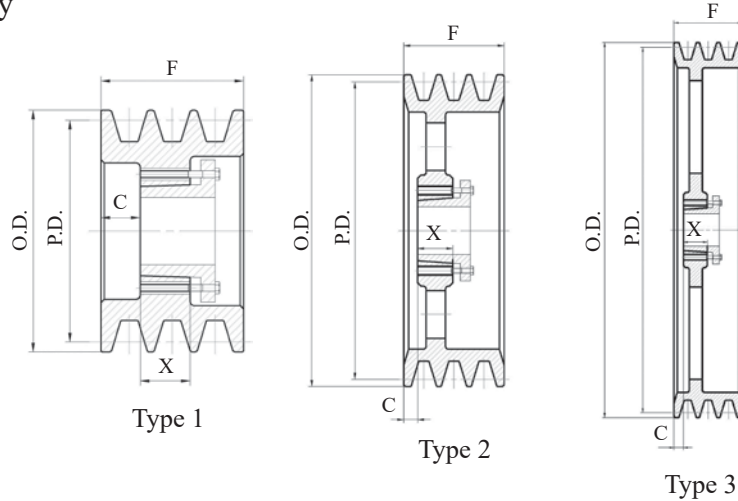

s = solid, ● lh = lighting hole, ⊙ sp = spoked ⊗

Part No.	Diameters			Type	Dimensions			
	O.D.	"4L or A" Pitch	"5L or B" Pitch		F	X	C	WT.
3BK45H	4.25	3.50	3.90	1 s	2 1/2	7/8	11/16	3.9
3BK47H	4.45	3.70	4.10	1 s	2 1/2	7/8	11/16	4.2
3BK50H	4.75	4.00	4.40	1 s	2 1/2	7/8	11/16	4.4
3BK52H	4.95	4.20	4.60	1 s	2 1/2	7/8	11/16	4.7
3BK55H	5.25	4.50	4.90	1 s	2 1/2	7/8	11/16	5.1
3BK57H	5.45	4.70	5.10	1 s	2 1/2	7/8	11/16	5.3
3BK60H	5.75	5.00	5.40	2 s	2 1/2	7/8	11/16	5.6
3BK62H	5.95	5.20	5.60	2 s	2 1/2	7/8	11/16	5.8
3BK65H	6.25	5.50	5.90	2 s	2 1/2	7/8	9/32	5.8
3BK67H	6.45	5.70	6.10	2 s	2 1/2	7/8	9/32	6.2
3BK70H	6.75	6.00	6.40	2 s	2 1/2	7/8	9/32	6.6
3BK80H	7.75	7.00	7.40	2 lh	2 1/2	7/8	11/32	8.3
3BK90H	8.75	8.00	8.40	2 lh	2 1/2	7/8	11/32	9.8
3BK100H	9.75	9.00	9.40	2 lh	2 1/2	7/8	11/32	10.9
3BK110H	10.75	10.00	10.40	2 lh	2 1/2	7/8	11/32	12.1
3BK120H	11.75	11.00	11.40	3 sp	2 1/2	7/8	11/32	14.3
3BK130H	12.75	12.00	12.40	3 sp	2 1/2	7/8	13/32	16.2
3BK140H	13.75	13.00	13.40	3 sp	2 1/2	7/8	13/32	17.7
3BK160H	15.75	15.00	15.40	3 sp	2 1/2	7/8	13/32	21.0
3BK190H	18.75	18.00	18.40	3 sp	2 1/2	7/8	13/32	25.8

Stock H Bushings and Metric bores on pages 89-90.

BK Sheaves are accurately machined from gray cast iron, statically balanced, painted and individually packaged.

Note: Cast iron sheaves may not exceed 6500 FPM. This speed **DOES NOT** specify if dynamic balancing (2 plane) is required. Contact customer service to verify whether dynamic balancing is required.

Cast Iron Sheaves - **Light-Duty** Bushed,
One Groove and
Two Groove

AK39HR to AK184HR -
2AK44HR to 2AK184HR

Order part number size

Example: AK39HR

Example: 2AK44HR

For All
1 Groove Sheaves

F= 3/4
L= 1 1/4
G= 7/16
E= 3/16
X= 7/8
P= 9/16
O.L.= 1 1/2



AKHR

For All
2 Groove Sheaves

F= 1 3/8
L= 1 1/4
X= 7/8
G= 1/2
E= 3/16
P= 1/16
O.L.= 1 1/2



2AKHR

For 3L, 4L or A Belts. See pages 100-103.

Order H bushing separately

All HR sheaves use standard
MasterDrive H bushings.

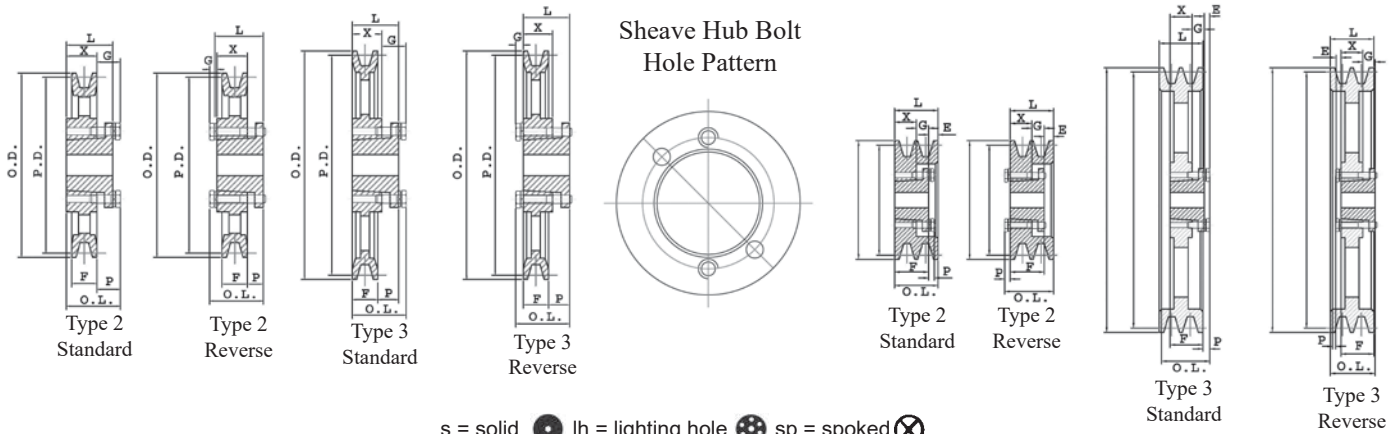

Part No.	Diameters			Type	WT.
	O.D.	Pitch			
		3L	4L or A		
AK39HR	3.75	3.16	3.50	2 s	1.50
AK41HR	3.95	3.36	3.70	2 s	1.80
AK44HR	4.25	3.66	4.00	2 s	2.00
AK46HR	4.45	3.86	4.20	2 s	2.30
AK49HR	4.75	4.16	4.50	2 s	2.60
AK51HR	4.95	4.36	4.70	2 s	2.70
AK54HR	5.25	4.66	5.00	2 s	2.60
AK56HR	5.45	4.86	5.20	2 s	2.80
AK59HR	5.75	5.16	5.50	2 s	3.00
AK61HR	5.95	5.36	5.70	3 s	3.10
AK64HR	6.25	5.66	6.00	3 s	3.30
AK66HR	6.45	5.86	6.20	3 s	3.60
AK69HR	6.75	6.16	6.50	3 lh	3.50
AK71HR	6.95	6.36	6.70	3 lh	3.50
AK74HR	7.25	6.66	7.00	3 lh	3.80
AK79HR	7.75	7.16	7.50	3 lh	4.20
AK84HR	8.25	7.66	8.00	3 lh	4.60
AK89HR	8.75	8.16	8.50	3 lh	4.80
AK94HR	9.25	8.66	9.00	3 lh	5.60
AK99HR	9.75	9.16	9.50	3 lh	5.90
AK104HR	10.25	9.66	10.00	3 sp	6.80
AK109HR	10.75	10.16	10.50	3 sp	7.10
AK114HR	11.25	10.66	11.00	3 sp	7.50
AK124HR	12.25	11.66	12.00	3 sp	8.00
AK134HR	13.25	12.66	13.00	3 sp	10.70
AK144HR	14.25	13.66	14.00	3 sp	11.10
AK154HR	15.25	14.66	15.00	3 sp	12.50
AK184HR	18.25	17.66	18.00	3 sp	17.30

Part No.	Diameters			Type	WT.
	O.D.	Pitch			
		3L	4L or A		
2AK44HR	4.25	3.66	4.00	2 s	2.90
2AK46HR	4.45	3.86	4.20	2 s	3.20
2AK49HR	4.75	4.16	4.50	2 s	3.70
2AK51HR	4.95	4.36	4.70	2 s	3.20
2AK54HR	5.25	4.66	5.00	2 s	3.50
2AK56HR	5.45	4.86	5.20	2 s	3.80
2AK59HR	5.75	5.16	5.50	3 s	4.10
2AK61HR	5.95	5.36	5.70	3 s	4.30
2AK64HR	6.25	5.66	6.00	3 s	4.60
2AK74HR	7.25	6.66	7.00	3 lh	5.10
2AK84HR	8.25	7.66	8.00	3 lh	6.10
2AK94HR	9.25	8.66	9.00	3 lh	7.40
2AK104HR	10.25	9.66	10.00	3 sp	9.20
2AK114HR	11.25	10.66	11.00	3 sp	10.00
2AK124HR	12.25	11.66	12.00	3 sp	10.90
2AK134HR	13.25	12.66	13.00	3 sp	13.10
2AK144HR	14.25	13.66	14.00	3 sp	14.60
2AK154HR	15.25	14.66	15.00	3 sp	16.20
2AK184HR	18.25	17.66	18.00	3 sp	21.60

Each HR Sheave includes an **HRBK** bolt kit to use in place of standard H bushing bolts.

AK Sheaves are accurately machined from gray cast iron, statically balanced, painted and individually packaged.

Note: Cast iron sheaves may not exceed 6500 FPM. This speed **DOES NOT** specify if dynamic balancing (2 plane) is required. Contact customer service to verify whether dynamic balancing is required.

All HR sheaves use standard MasterDrive H bushings.

Stock H Bushings and Metric bores on pages 89-90.

HR Bushing Sheaves

Cast Iron Sheaves - Light Duty

Bushed, One Groove and Two Groove

BK36HR to BK190HR - 2BK50HR to 2BK190HR

Order part number size

Example: BK36HR

Example: 2BK50HR

For 4L or A, 5L or B Belts.

See pages 100-108.

Order H bushings separately

All HR sheaves use standard

MasterDrive H bushings.

For All
1 Groove Sheaves

F= 7/8
L= 1 1/4
G= 7/16
E= 3/16
X= 7/8



BKHR

For All
2 Groove
Sheaves

F= 1 3/4
L= 1 1/4
X= 7/8
G= 7/16
E= 3/16
P= 7/16
O.L.= 1 3/4



2BKHR

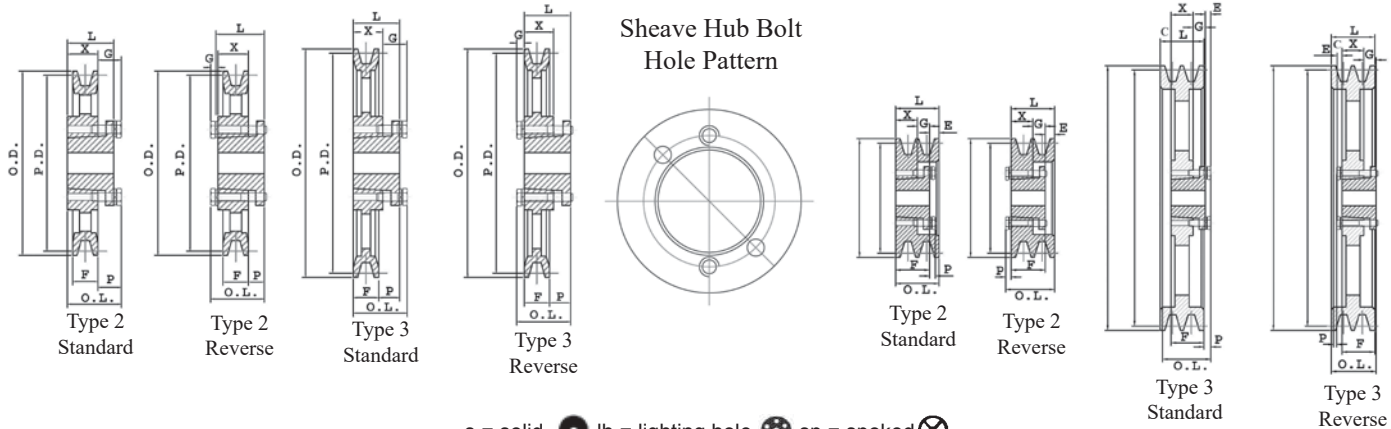

Part No.	Diameters			Type	Dimensions			
	O.D.	Pitch "4L or A" "5L or B"			O.L.	P	C	WT.
BK36HR	3.75	3.00	3.40	2 s	1 1/2	7/16	-	1.5
BK40HR	3.95	3.20	3.60	2 s	1 1/2	7/16	-	1.7
BK45HR	4.25	3.50	3.90	2 s	1 1/2	7/16	-	2.1
BK47HR	4.45	3.70	4.10	2 s	1 1/2	7/16	-	2.3
BK50HR	4.75	4.00	4.40	2 s	1 1/2	7/16	-	2.7
BK52HR	4.95	4.20	4.60	2 s	1 1/2	7/16	-	3.0
BK55HR	5.25	4.50	4.90	2 s	1 1/2	7/16	-	3.5
BK57HR	5.45	4.70	5.10	2 s	1 1/2	7/16	-	3.6
BK60HR	5.75	5.00	5.40	2 s	1 1/2	7/16	-	3.5
BK62HR	5.95	5.20	5.60	2 s	1 1/2	7/16	-	3.7
BK65HR	6.25	5.50	5.90	2 s	1 1/2	7/16	-	4.0
BK67HR	6.45	5.70	6.10	2 s	1 1/2	7/16	-	4.0
BK70HR	6.75	6.00	6.40	3 s	1 9/16	1/2	1/16	4.7
BK72HR	6.95	6.20	6.60	3 s	1 9/16	1/2	1/16	4.7
BK75HR	7.25	6.50	6.90	3 lh	1 9/16	1/2	1/16	4.7
BK77HR	7.45	6.70	7.10	3 lh	1 9/16	1/2	1/16	4.8
BK80HR	7.75	7.00	7.40	3 lh	1 9/16	1/2	1/16	5.3
BK85HR	8.25	7.50	7.90	3 lh	1 9/16	1/2	1/16	5.5
BK90HR	8.75	8.00	8.40	3 lh	1 9/16	1/2	1/16	6.0
BK95HR	9.25	8.50	8.90	3 lh	1 9/16	1/2	1/16	6.7
BK100HR	9.75	9.00	9.40	3 lh	1 9/16	1/2	1/16	7.1
BK105HR	10.25	9.50	9.90	3 lh	1 9/16	1/2	1/16	7.5
BK110HR	10.75	10.00	10.40	3 sp	1 9/16	1/2	1/16	8.6
BK115HR	11.25	10.50	10.90	3 sp	1 9/16	1/2	1/16	8.8
BK120HR	11.75	11.00	11.40	3 sp	1 9/16	1/2	1/16	9.2
BK130HR	12.75	12.00	12.40	3 sp	1 9/16	1/2	1/16	10.6
BK140HR	13.75	13.00	13.40	3 sp	1 9/16	1/2	1/16	12.9
BK150HR	14.75	14.00	14.40	3 sp	1 9/16	1/2	1/16	14.4
BK160HR	15.75	15.00	15.40	3 sp	1 9/16	1/2	1/16	15.5
BK190HR	18.75	18.00	18.40	3 sp	1 9/16	1/2	1/16	21.1

Part No.	Diameters			Type	Dimensions	
	O.D.	Pitch "4L or A" "5L or B"			C	WT.
2BK50HR	4.75	4.00	4.40	2 s	-	4.4
2BK52HR	4.95	4.20	4.60	2 s	-	4.8
2BK55HR	5.25	4.50	4.90	2 s	-	5.4
2BK57HR	5.45	4.70	5.10	2 s	-	5.3
2BK60HR	5.75	5.00	5.40	2 s	-	5.6
2BK62HR	5.95	5.20	5.60	2 s	-	5.8
2BK65HR	6.25	5.50	5.90	3 s	1/4	6.4
2BK67HR	6.45	5.70	6.10	3 s	1/4	6.7
2BK70HR	6.75	6.00	6.40	3 s	1/4	7.2
2BK80HR	7.75	7.00	7.40	3 lh	1/4	8.3
2BK90HR	8.75	8.00	8.40	3 lh	1/4	9.8
2BK100HR	9.75	9.00	9.40	3 lh	1/4	11.5
2BK110HR	10.75	10.00	10.40	3 sp	1/4	13.6
2BK120HR	11.75	11.00	11.40	3 sp	1/4	15.0
2BK130HR	12.75	12.00	12.40	3 sp	1/4	16.7
2BK140HR	13.75	13.00	13.40	3 sp	1/4	19.8
2BK160HR	15.75	15.00	15.40	3 sp	1/4	24.5
2BK190HR	18.75	18.00	18.40	3 sp	1/4	26.0

Each HR Sheave includes an **HRBK** bolt kit to use in place of standard H bushing bolts.

BK Sheaves are accurately machined from gray cast iron, statically balanced, painted and individually packaged.

Note: Cast iron sheaves may not exceed 6500 FPM. This speed **DOES NOT** specify if dynamic balancing (2 plane) is required. Contact customer service to verify whether dynamic balancing is required.

All HR sheaves use standard MasterDrive H bushings.

Cast Iron Sheaves - **Light Duty**
Bored-to Size,
One Groove and
Two Groove
1VP and 2VP Dimensions



VP

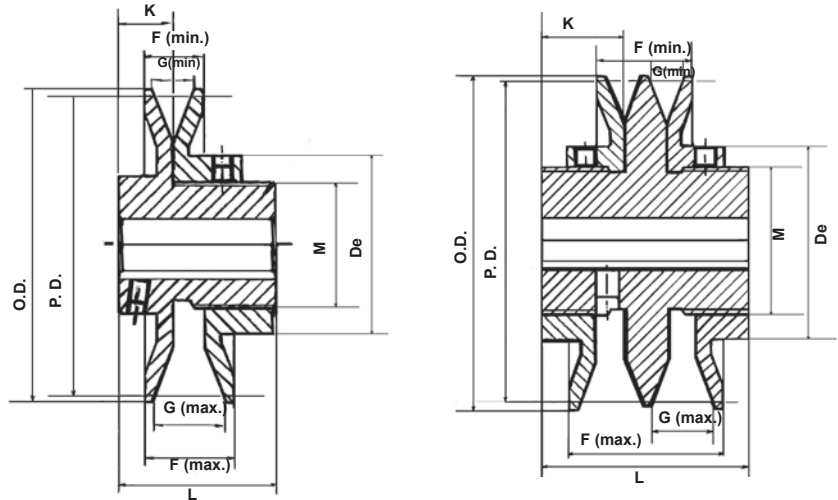

1VP Sheaves may be used with 3L, 4L, 5L, A, B and 5V Belts. See pages 100-108 & 113.

Part No.	O.D.	F		G		L	K	Bore	M	De	Avg. Wt.
		Max	Min	Max	Min						
1VP25	2.380	0.810	0.560	0.630	0.380	1.590	0.620	1/2, 5/8, 3/4	1.375	2.00	1.0
1VP30	2.870	0.810	0.560	0.630	0.380	1.660	0.630	1/2, 5/8, 3/4	1.500	2.13	1.4
1VP34	3.150	1.000	0.690	0.810	0.500	1.880	0.780	1/2, 5/8, 3/4, 7/8, 1, 1 1/8	1.500 1.750	2.13 2.38	1.5 1.7
1VP40	3.750	1.060	0.690	0.880	0.500	1.880	0.660	1/2, 5/8, 3/4, 7/8, 1, 1 1/8	1.500 1.750	2.13 2.38	2.0 2.0
1VP44	4.150	1.060	0.690	0.880	0.500	1.880	0.660	1/2, 5/8, 3/4, 7/8, 1, 1 1/8	1.500 1.750	2.13 2.38	2.2 2.2
1VP50	4.750	1.060	0.690	0.880	0.500	2.000	0.780	1/2, 5/8, 3/4, 7/8, 1, 1 1/8	1.500 1.750	2.13 2.38	2.7 2.8
1VP56	5.350	1.060	0.690	0.880	0.500	2.000	0.780	1/2, 5/8, 3/4, 7/8, 1, 1 1/8	1.750	2.38	3.4
1VP60	6.000	1.250	0.880	1.031	0.660	2.160	0.850	5/8, 3/4, 7/8, 1 1/8, 1 3/8, 1 5/8	2.000 2.500	2.62 3.29	4.6 5.3
1VP62	5.950	1.250	0.880	1.031	0.660	2.000	0.780	5/8, 3/4, 7/8, 1, 1 1/8, 1 1/4, 1 3/8	2.000 2.500	2.62 3.29	4.6 5.1
1VP65	6.500	1.250	0.880	1.030	0.660	2.160	0.850	3/4, 7/8, 1 1/8, 1 3/8	2.000 2.500	2.62 3.29	5.3 5.8
1VP68	6.550	1.250	0.880	1.030	0.660	2.000	0.780	5/8, 3/4, 7/8, 1, 1 1/8, 1 1/4, 1 3/8	2.000 2.500	2.62 3.29	5.2 5.8
1VP71	7.100	1.250	0.880	1.030	0.660	2.160	0.850	3/4, 7/8, 1 1/8, 1 3/8, 1 5/8	2.000 2.500	2.62 3.29	6.5 6.8
1VP75	7.500	1.250	0.880	1.030	0.660	2.160	0.850	3/4, 7/8, 1 1/8, 1 3/8, 1 5/8	2.000 2.500	2.62 3.29	7.0 7.6

2VP Sheaves may be used with 3L, 4L, 5L, A, B and 5V Belts. See pages 100-108 & 113.

Part No.	O.D.	F		G		L	K	Bore	M	De	Avg. Wt.
		Max	Min	Max	Min						
2VP36	3.350	2.000	1.380	0.810	0.500	3.000	1.190	1/2, 5/8, 3/4, 7/8, 1, 1 1/8	2.000	2.62	3.8
2VP42	3.950	2.130	1.380	0.880	0.500	3.000	1.190	5/8, 3/4, 7/8, 1, 1 1/8	2.000	2.62	4.7
2VP50	4.750	2.130	1.380	0.880	0.500	3.000	1.190	5/8, 3/4, 7/8, 1, 1 1/8	2.125	2.75	6.3
2VP56	5.350	2.130	1.380	0.880	0.500	3.000	1.190	5/8, 3/4, 7/8, 1, 1 1/8, 1 3/8, 1 5/8	2.125 2.500	2.75 3.29	7.7 8.0
2VP60	6.000	2.380	1.630	1.030	0.660	3.250	1.250	3/4, 7/8, 1, 1 1/8, 1 3/8, 1 5/8	2.125 2.500	2.75 3.29	9.8 9.8
2VP62	5.950	2.380	1.630	1.030	0.660	3.000	1.190	3/4, 7/8, 1, 1 1/8, 1 3/8, 1 5/8	2.125 2.500	2.75 3.29	9.0 9.4
2VP65	6.500	2.380	1.630	1.030	0.660	3.250	1.250	3/4, 7/8, 1 1/8, 1 3/8, 1 5/8	2.125 2.500	2.75 3.29	11.0 12.2
2VP68	6.550	2.380	1.630	1.030	0.660	3.000	1.190	3/4, 7/8, 1, 1 1/8, 1 1/4, 1 3/8, 1 5/8	2.125 2.500	2.75 3.29	10.4 10.9
2VP71	7.100	2.380	1.630	1.030	0.660	3.250	1.250	3/4, 7/8, 1 1/8, 1 3/8, 1 5/8	2.125 2.500	2.75 3.29	13.4 14.3
2VP75	7.500	2.380	1.630	1.030	0.660	3.250	1.250	3/4, 7/8, 1 1/8, 1 3/8, 1 5/8	2.125 2.500	2.75 3.29	14.6 15.0

All 1VP & 2VP sheaves are furnished with standard keyway and (2) 5/16-18 knurled setscrews over each slot & in bore.

Light Duty Adjustable Sheaves

Cast Iron Sheaves - **Light Duty**
Bored-to Size,
One Groove
VL Sheaves

Order part number size
Example: 1VL25-5/8

VL Sheaves may be used with 3L,
4L, 5L, A and B Belts. See pages 100-105.

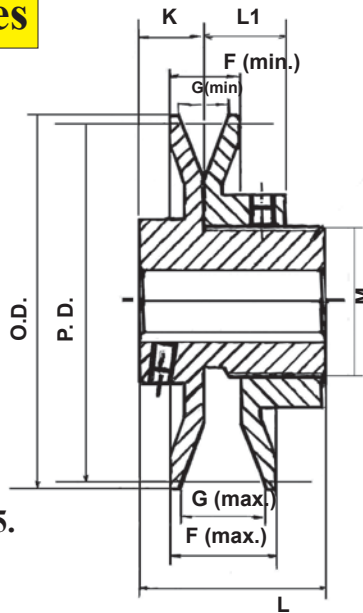

VL

All VL sheaves are furnished with standard keyway and (3) 5/16-18 x 5/16 knurled set screws.

Part No.	O.D.	F		G		L	L1	K	M	Bore	Avg. Wt.
		Max	Min	Max	Min						
1VL25	2.500	0.781	0.531	0.625	0.375	1.634	0.728	0.697	1.125	1/2, 5/8	.85
1VL30	2.870	0.781	0.531	0.625	0.375	1.634	0.728	0.697	1.125	1/2, 5/8	1.1
1VL34	3.150	1.000	0.625	0.875	0.500	1.933	0.815	0.744	1.125	1/2, 5/8,	1.1
									1.375	3/4	1.3
1VL40	3.750	1.000	0.625	0.875	0.500	1.933	0.815	0.744	1.125	1/2, 5/8,	1.5
									1.375	3/4, 7/8,	1.5
1VL44	4.150	1.000	0.625	0.875	0.500	1.933	0.815	0.744	1.125	1/2, 5/8,	1.6
									1.375	3/4, 7/8	1.7
1VM50	4.750	1.060	0.688	0.875	0.500	1.996	0.846	0.776	1.125	1/2, 5/8,	2.4
									1.375	3/4, 7/8	2.4

Cast Iron Sheaves - **Light Duty**
Bored-to Size,
One Groove
AL Sheaves

Order part number size
Example: no keyway = AL54-5/8, with keyway = AL54-5/8KW
AL Sheaves may be used with 4L, A Belts.

See pages 100-102.

AL Sheaves come with or without Keyway and are for Light Applications - Fans, Air Conditioning Units, Furnace Blowers etc.

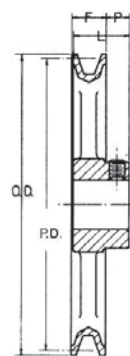

AL

Part No.	O.D.	Pitch	F	L	P	Bore	Hub O.D.	Avg. Wt.
AL54	4.93	4.78	.593	1.062	.468	5/8, 3/4, 1	1.7	1.2
AL64	5.93	5.78	.593	1.062	.468	5/8, 3/4, 1	1.7	1.4
AL74	6.93	6.78	.593	1.062	.468	5/8, 3/4, 1	1.7	1.7
AL84	7.93	7.78	.593	1.062	.468	5/8, 3/4, 1	1.7	1.9
AL94	8.93	8.78	.593	1.062	.468	3/4, 1	1.9	2.6
AL104	9.93	9.78	.593	1.062	.468	3/4, 1	2.0	3.0
AL114	10.93	10.78	.593	1.062	.468	3/4, 1	2.0	3.5
AL124	11.93	11.78	.593	1.062	.468	3/4, 1	2.0	4.0
AM144	14.16	14.00	.687	1.750	.406	1	2.0	5.2

Rework Charges for : Rebores, Keyways, additional setscrews - P.O.R. All AL sheaves are statically balanced and include (1) 5/16-18 knurled setscrew.

Part No.	DIAMETER RANGES											
	"3L" Belts				"4L" or "A" Belts				"5L" or "B" Belts			
	Min Pitch	Turns Open	Max. Pitch	Turns Open	Min. Pitch	Turns Open	Max. Pitch	Turns Open	Min. Pitch	Turns Open	Max. Pitch	Turns Open
1VL25	1.6	4	2.4	0	-	-	-	-	-	-	-	-
1VL30	1.8	4	2.7	0	-	-	-	-	-	-	-	-
1VL34	1.7	4	2.5	0	1.9	5	2.9	0	2.4	5	3.2	1
1VL40	2.3	4	3.1	0	2.4	5	3.4	0	2.7	6	3.7	1
1VL44	2.7	4	3.5	0	2.8	5	3.8	0	3.1	6	4.1	1
1VM50	3.3	4	4.1	0	3.4	5	4.4	0	3.7	6	4.7	1

Part No.	DIAMETER RANGES															
	"3L" Belts				"4L" or "A" Belts				"5L" or "B" Belts				"5V" Belts			
	Min Pitch	Turns Open	Max. Pitch	Turns Open	Min. Pitch	Turns Open	Max. Pitch	Turns Open	Min. Pitch	Turns Open	Max. Pitch	Turns Open	Min. Pitch	Turns Open	Max. Pitch	Turns Open
2VP36	1.9	4	2.7	0	2.0	5	3.0	0	2.5	5	3.3	1	-	-	-	-
2VP42	2.5	4	3.3	0	2.6	5	3.6	0	2.9	6	3.9	1	-	-	-	-
2VP50	3.3	4	4.1	0	3.4	5	4.4	0	3.7	6	4.7	1	-	-	-	-
2VP56	3.9	4	4.7	0	4.0	5	5.0	0	4.3	6	5.3	1	-	-	-	-
2VP60	-	-	-	-	4.2	5	5.2	0	4.3	6	5.5	0	4.7	6	5.9	0
2VP62	-	-	-	-	4.2	5	5.2	0	4.3	6	5.5	0	4.7	6	5.9	0
2VP65	-	-	-	-	4.7	5	5.7	0	4.8	6	6.0	0	5.2	6	6.4	0
2VP68	-	-	-	-	4.7	5	5.7	0	4.8	6	6.0	0	5.2	6	6.4	0
2VP71	-	-	-	-	5.3	5	6.3	0	5.4	6	6.6	0	5.8	6	7.0	0
2VP75	-	-	-	-	5.7	5	6.7	0	5.8	6	7.0	0	6.2	6	7.4	0

Part No.	DIAMETER RANGES															
	"3L" Belts				"4L" or "A" Belts				"5L" or "B" Belts				"5V" Belts			
	Min Pitch	Turns Open	Max. Pitch	Turns Open	Min. Pitch	Turns Open	Max. Pitch	Turns Open	Min. Pitch	Turns Open	Max. Pitch	Turns Open	Min. Pitch	Turns Open	Max. Pitch	Turns Open
1VP25	1.6	4	2.4	0	-	-	-	-	-	-	-	-	-	-	-	-
1VP30	1.8	4	2.7	0	-	-	-	-	-	-	-	-	-	-	-	-
1VP34	1.7	4	2.5	0	1.9	5	2.9	0	2.4	5	3.2	1	-	-	-	-
1VP40	2.3	4	3.1	0	2.4	5	3.4	0	2.7	6	3.7	1	-	-	-	-
1VP44	2.7	4	3.5	0	2.8	5	3.8	0	3.1	6	4.1	1	-	-	-	-
1VP50	3.3	4	4.1	0	3.4	5	4.4	0	3.7	6	4.7	1	-	-	-	-
1VP56	3.9	4	4.7	0	4.0	5	5.0	0	4.3	6	5.3	1	-	-	-	-
1VP60	-	-	-	-	4.2	5	5.2	0	4.3	6	5.5	0	-	-	-	-
1VP62	-	-	-	-	4.2	5	5.2	0	4.3	6	5.5	0	4.7	6	5.9	0
1VP65	-	-	-	-	4.7	5	5.7	0	4.8	6	6.0	0	5.2	6	6.4	0
1VP68	-	-	-	-	4.7	5	5.7	0	4.8	6	6.0	0	5.2	6	6.4	0
1VP71	-	-	-	-	5.3	5	6.3	0	5.4	6	6.6	0	5.8	6	7.0	0
1VP75	-	-	-	-	5.7	5	6.7	0	5.8	6	7.0	0	6.2	6	7.4	0

Installation and Operation Instructions

VL-VP FHP Adjustable Sheaves

- Loosen all setscrews on the sheave. Rotate the adjustable flange(s) to make the face width of the adjustable sheave the same as the face width of the companion sheave.
- Inspect the motor shaft and key for any nicks or burrs and remove if present. Install shaft key. Slide the sheave onto the motor shaft.
- Align the adjustable sheave with the companion sheave by using a straight edge or piece of string. This is most easily accomplished by using the four-point method shown below. Note: Dimensions, A, B, C and D must be equal for correct alignment.



- Secure the sheave to motor shaft by tightening the setscrew over the key to the proper torque (110-130 in. lbs. torque for 5/16" setscrews and 50-70 in. lbs. torque for 1/4"). Note: On two groove sheaves the setscrew is located at the base of the center flange. You may need to adjust the flange open to expose it.
- Adjust the sheave to the desired pitch diameter. Each turn of the flange changes the pitch diameter approximately .16 inches. Six turns are required to adjust the sheave from minimum to maximum for B (5L) belts, six turns for A (4L) belts, five turns for (3L) belts; and seven turns for (5V) belts. Note: You must adjust both flanges of a two-groove sheave equally so belts will ride evenly.
- Lock the adjustable flange(s) into position by tightening the setscrew(s) to the proper torque (5/16" setscrew – 110-130 in. lbs. torque, 1/4" setscrews – 60-70 in. lbs. torque). Warning: To prevent damage to hub threads, the set screw(s) must be over the flats or in the machined groove. If the flange is not properly locked, the sheave will fail prematurely.
- Install and properly tension belts.

WARNING

Rotating equipment can cause personal injury. BE SAFE install a guard around the drive to keep anything from coming into contact with moving parts.

- Start the drive. If a speed correction is necessary, stop the drive and remove the guard and belts. Adjust the sheave as per steps 5 through 7.

Light Duty Cross Reference Chart

Bored-To-Size

**A Section
Single Groove**

MasterDrive Part#	Maska Part#	Maurey Part#
AK17	MA18	2175
AK20	MA20	2200
AK21	MA21	2210
AK22	MA22	2225
AK23	MA23	-
AK25	MA25	2250
AK26	MA26	2260
AK27	MA27	2275
AK28	MA28	-
AK30	MA30	AC31
AK32	MA33	AC33
AK34	MA35	AC35
AK39	MA38	AC38
AK41	MA40	AC40
AK44	MA43	AC43
AK46	MA45	AC45
AK49	MA48	AC48
AK51	MA50	AC50
AK54	MA53	AC53
AK56	MA55	AC55
AK59	MA58	AC58
AK61	MA60	AC60
AK64	MA63	AC63
AK66	MA65	AC65
AK69	MA68	AC68
AK71	MA70	AC70
AK74	MA73	AC73
AK79	MA78	AC78
AK84	MA83	AC83
AK89	MA88	AC88
AK94	MA93	AC93
AK99	MA98	-
AK104	MA103	AC103
AK109	MA108	-
AK114	MA113	AC113
AK124	MA123	AC123
AK134	MA133	AC133
AK144	MA143	AC143
AK154	MA153	AC153
AK184	MA183	AC183

**A Section
Double Groove**

MasterDrive Part#	Maska Part#	Maurey Part#
2AK20	2MA20	D2200
2AK21	2MA22	-
2AK22	2MA23	D2225
2AK23	2MA24	-
2AK25	2MA25	D2250
2AK26	2MA27	-
2AK27	2MA28	D2275
2AK28	2MA29	-
2AK30	2MA30	-
2AK32	2MA33	D2325
2AK34	2MA35	D2350
2AK39	2MA38	D2380
2AK41	2MA40	D2400
2AK44	2MA43	D2425
2AK46	2MA45	D2450
2AK49	2MA48	D2480
2AK51	2MA50	D2500
2AK54	2MA53	D2525
2AK56	2MA55	D2550
2AK59	2MA58	D2580
2AK61	2MA60	D2600
2AK64	2MA63	-
2AK74	2MA73	D2725
2AK84	2MA83	-
2AK94	2MA93	D2925
2AK104	2MA103	D3103
2AK114	2MA113	-
2AK124	2MA123	D3123
2AK134	2MA133	-
2AK144	2MA143	D3143
2AK154	2MA153	D3153
2AK184	2MA183	D3183

**B Section
Single Groove**

MasterDrive Part#	Maska Part#	Maurey Part#
BK24	MB24	-
BK25	MB25	4250
BK26	MB26	4260
BK27	MB28	-
BK28	MB30	BC30
BK30	MB31	BC32
BK32	MB34	BC34
BK34	MB35	BC36
BK36	MB38	BC38
BK40	MB40	BC40
BK45	MB43	-
BK47	MB45	-
BK50	MB48	BC48
BK52	MB50	BC50
BK55	MB53	-
BK57	MB55	-
BK60	MB58	BC58
BK62	MB60	BC60
BK65	MB63	-
BK67	MB65	-
BK70	MB68	BC68
BK72	MB70	BC70
BK75	MB73	BC73
BK77	MB75	-
BK80	MB78	BC78
BK85	MB83	BC83
BK90	MB88	BC88
BK95	MB93	BC93
BK100	MB98	BC98
BK105	MB103	-
BK110	MB108	-
BK115	MB113	-
BK120	MB118	BC118
BK130	MB128	BC128
BK140	MB138	-
BK160	MB158	BC158
BK190	MB188	BC188

**B Section
Double Groove**

MasterDrive Part#	Maska Part#	Maurey Part#
2BK25	2MB25	D4250
2BK27	2MB28	D4280
2BK28	2MB30	D4300
2BK30	2MB32	D4320
2BK32	2MB34	D4340
2BK34	2MB35	D4360
2BK36	2MB38	D4380
2BK40	2MB40	D4400
2BK45	2MB43	-
2BK47	2MB45	-
2BK50	2MB48	D4480
2BK52	2MB50	D4500
2BK55	2MB53	-
2BK57	2MB55	-
2BK60	2MB58	D4580
2BK62	2MB60	D4600
2BK65	2MB63	-
2BK67	2MB65	-
2BK70	2MB68	D4680
2BK80	2MB78	D4780
2BK90	2MB88	D4880
2BK100	2MB98	D4980
2BK110	2MB108	D5108
2BK120	2MB118	D5118
2BK130	2MB128	D5128
2BK140	2MB138	-
2BK160	2MB158	D5158
2BK190	2MB188	D5188

**A Section
Single Groove**

**A Section
Double Groove**

**B Section
Single Groove**

**B Section
Double Groove**

MasterDrive Part#	Maska Part#	Maurey Part#	MasterDrive Part#	Maska Part#	Maurey Part#	MasterDrive Part#	Maska Part#	Maurey Part#	MasterDrive Part#	Maska Part#	Maurey Part#
AK30H	MAL30	-	2AK30H	2MAL30	DH2300	BK36H	MBL37	BH38	2BK32H	2MBL33	DH4340
AK32H	MAL32	-	2AK32H	2MAL32	DH2325	BK40H	MBL39	BH40	2BK34H	2MBL35	DH4360
AK34H	MAL34	-	2AK34H	2MAL34	DH2350	BK45H	MBL42	-	2BK36H	2MBL37	DH4380
AK39H	MAL37	-	2AK39H	2MAL37	DH2380	BK47H	MBL44	-	2BK40H	2MBL39	DH4400
AK41H	MAL39	AH40	2AK41H	2MAL39	DH2400	BK50H	MBL47	BH48	2BK45H	2MBL42	-
AK44H	MAL42	AH43	2AK44H	2MAL42	DH2425	BK52H	MBL49	BH50	2BK47H	2MBL44	-
AK46H	MAL44	AH45	2AK46H	2MAL44	DH2450	BK55H	MBL52	BH53	2BK50H	2MBL47	DH4480
AK49H	MAL47	AH48	2AK49H	2MAL47	DH2480	BK57H	MBL54	-	2BK52H	2MBL49	DH4500
AK51H	MAL49	AH50	2AK51H	2MAL49	DH2500	BK60H	MBL57	BH58	2BK55H	2MBL52	-
AK54H	MAL52	AH53	2AK54H	2MAL52	DH2525	BK62H	MBL59	BH60	2BK57H	2MBL54	-
AK56H	MAL54	AH55	2AK56H	2MAL54	DH2550	BK65H	MBL62	-	2BK60H	2MBL57	DH4580
AK59H	MAL57	-	2AK59H	2MAL57	DH2580	BK67H	MBL64	-	2BK62H	2MBL59	DH4600
AK61H	MAL59	AH60	2AK61H	2MAL59	DH2600	BK70H	MBL67	BH68	2BK65H	2MBL62	-
AK64H	MAL62	AH63	2AK64H	2MAL62	-	BK72H	MBL69	BH70	2BK67H	2MBL64	-
AK66H	MAL64	AH65	2AK74H	2MAL72	DH2730	BK75H	MBL72	BH73	2BK70H	2MBL67	DH4680
AK69H	MAL67	AH68	2AK84H	2MAL82	-	BK77H	MBL74	-	2BK80H	2MBL77	DH4780
AK71H	MAL69	AH70	2AK94H	2MAL92	DH2930	BK80H	MBL77	BH78	2BK90H	2MBL87	DH4880
AK74H	MAL72	AH73	2AK104H	2MAL102	DH3103	BK85H	MBL82	BH83	2BK100H	2MBL97	DH4980
AK79H	MAL77	AH78	2AK114H	2MAL112	-	BK90H	MBL87	BH88	2BK110H	2MBL107	DH5108
AK84H	MAL82	AH83	2AK124H	2MAL122	DH3123	BK95H	MBL92	-	2BK120H	2MBL117	DH5118
AK89H	MAL87	AH88	2AK134H	2MAL132	-	BK100H	MBL97	BH98	2BK130H	2MBL127	DH5128
AK94H	MAL92	AH93	2AK144H	2MAL142	DH3143	BK105H	MBL102	-	2BK140H	2MBL137	-
AK99H	MAL97	-	2AK154H	2MAL152	DH3153	BK110H	MBL107	BH108	2BK160H	2MBL157	DH5158
AK104H	MAL102	AH103	2AK184H	2MAL182	DH3183	BK115H	MBL112	-	2BK190H	2MBL187	DH5188
AK109H	MAL107	-	B Section Single Groove			BK120H	MBL117	BH118			
AK114H	MAL112	AH113				BK130H	MBL127	BH128			
AK124H	MAL122	AH123	MasterDrive Part#	Maska Part#	Maurey Part#	BK140H	MBL137	-			
AK134H	MAL132	AH133	BK30H	MBL31	BH32	BK150H	MBL147	-			
AK144H	MAL142	AH143	BK32H	MBL33	BH34	BK160H	MBL157	BH158			
AK154H	MAL152	AH153	BK34H	MBL35	BH36	BK190H	MBL187	BH188			
AK184H	MAL182	AH183									

**Air Handling
AL/AM
Single Groove**

**VL/VM
Light Duty**

**Variable Pitch
1VP
Single Groove**

**2VP
Double Groove**

MasterDrive Part#	Maska Part#	Maurey Part#	MasterDrive Part#	Maska Part#	Maurey Part#	MasterDrive Part#	Maska Part#	Maurey Part#	MasterDrive Part#	Maska Part#	Maurey Part#
AL54	MFAL54	-	1VL25	MVL25	-	1VP25	-	-	2VP36	D8350	-
AL64	MFAL64	-	1VL30	MVL30	-	1VP30	-	-	2VP42	D8400	-
AL74	MFAL74	-	1VL34	MVL34	-	1VP34	8325	-	2VP50	D8450	D8450
AL84	MFAL84	-	1VL40	MVL40	-	1VP40	8350	8350	2VP56	D8550	D8550
AL94	MFAL94	-	1VL44	MVL44	-	1VP44	8400	8400	2VP60	D8600	D8575
AL104	MFAL104	-	1VM50	-	-	1VP50	8450	8450	2VP62	D8600	D8600
AL114	MFAL114	-				1VP56	8550	8550	2VP65	D8600	-
AL124	MFAL124	-				1VP60	8600	8575	2VP68	D8670	-
AM144	MFAM144	-				1VP62	8600	8600	2VP71	D8670	-
						1VP65	8600	-	2VP75	D8740	-
						1VP68	8670	-			
						1VP71	8670	-			
						1VP75	8740	-			

Features/Benefits of:

Heavy Duty Stock Sheave & Bushing Combinations

QD Sheaves & Bushings

- Sheaves available for belt sizes: A/B, C, 3V, 5V and 8V
- 1-12 groove
- Max. O.D. 71"
- Bushings stock in JA thru W sizes
- Bushings SH-W include a set screw in flange over keyway.
- Sheave/bushing can be reverse mounted (Bolts thru sheave then into bushing OR bolts thru bushing then into sheave)



DST Sheaves & Bushings

- Sheaves available for A/B section belts
- 1-4 groove
- Max. O.D. 38"
- DST sheaves offer more sizes from 3.75" O.D. up to 38.35" O.D. as compared to QD and TB.
- Bushings stock in G-H-P1-P2- Q1-Q2-R1 & R2
- Longest LTB (length thru bore) of all bushings
- Bushing and sheave use an additional key between the O.D. of bushing and I.D. of hub to transmit torque.



TB Sheaves & Bushings

- Sheaves available for belt sizes: A/B, 3V and 5V
- 1-6 groove
- Max. O.D. 50"
- Bushings stock in sizes 1008 thru 5050
- No flange or hub
- Shortest LTB (length thru bore) of all bushings
- Flush mounting, no exposed bolts



**ALL bushings stocked in inch & metric sizes.
Rework machining available from Wisconsin.**

Cast Iron Sheaves - Heavy Duty
Bushed, One and Two Groove
A-B QD Sheaves
Order part number size
Example: 1B34SH



For A, AX, B & BX V-Belts.
See pages 102-108
Order QD bushings separately
Stock Bushings Located
on Pages 84-85.

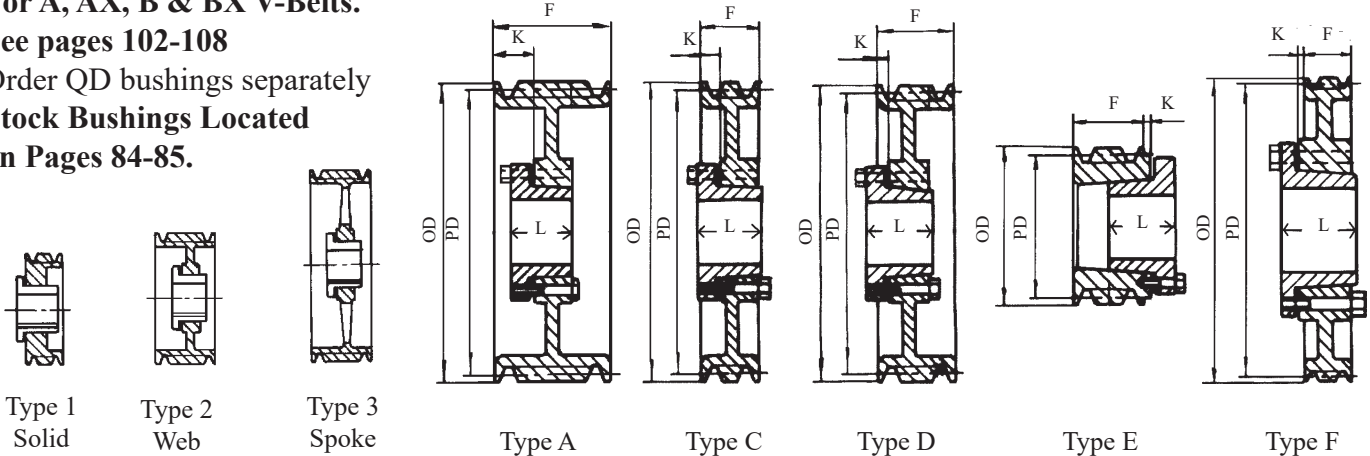

O.D.	P.D.		1 Groove F = 1B34SH THRU 1B64SDS = 7/8 1B66SDS THRU 1B300SF = 1						2 Groove F = 1 3/4					
	A	B	Part No.	Bush	Type	K	L	WT.	Part No.	Bush	Type	K	L	WT.
3.75	3.00	3.40	1B34SH	SH	D-1	0	1 5/16	1.4	*2B34SH	SH	E-1	0	1 5/16	2.4
3.95	3.20	3.60	1B36SH	SH	D-1	0	1 5/16	1.6	*2B36SH	SH	D-1	3/16	1 5/16	2.7
4.15	3.40	3.80	1B38SH	SH	D-1	0	1 5/16	1.7	*2B38SH	SH	D-1	3/16	1 5/16	2.9
4.35	3.60	4.00	1B40SH	SH	C-1	1/16	1 5/16	1.9	+2B40SH	SH	A-1	11/16	1 5/16	3.2
4.55	3.80	4.20	1B42SH	SH	C-1	1/16	1 5/16	2.2	+2B42SH	SH	A-1	11/16	1 5/16	3.7
4.75	4.00	4.40	1B44SH	SH	C-1	1/16	1 5/16	2.5	2B44SH	SH	A-1	11/16	1 5/16	4.1
4.95	4.20	4.60	1B46SDS	SDS	C-1	1/8	1 5/16	2.5	2B46SDS	SDS	A-1	11/16	1 5/16	4.2
5.15	4.40	4.80	1B48SDS	SDS	C-1	1/8	1 5/16	2.8	2B48SDS	SDS	A-1	11/16	1 5/16	4.6
5.35	4.60	5.00	1B50SDS	SDS	C-1	1/8	1 5/16	3.1	2B50SDS	SDS	A-1	11/16	1 5/16	5.0
5.55	4.80	5.20	1B52SDS	SDS	C-1	1/8	1 5/16	3.3	2B52SDS	SDS	A-1	11/16	1 5/16	5.4
5.75	5.00	5.40	1B54SDS	SDS	C-1	1/8	1 5/16	3.7	2B54SDS	SDS	A-1	11/16	1 5/16	5.8
5.95	5.20	5.60	1B56SDS	SDS	C-1	1/8	1 5/16	4.2	2B56SDS	SDS	A-1	11/16	1 5/16	6.1
6.15	5.40	5.80	1B58SDS	SDS	C-1	1/8	1 5/16	3.9	2B58SDS	SDS	A-1	11/16	1 5/16	6.1
6.35	5.60	6.00	1B60SDS	SDS	C-2	1/8	1 5/16	4.0	2B60SDS	SDS	A-2	11/16	1 5/16	6.4
6.55	5.80	6.20	1B62SDS	SDS	C-2	1/8	1 5/16	4.2	2B62SDS	SDS	A-2	11/16	1 5/16	6.7
6.75	6.00	6.40	1B64SDS	SDS	C-2	1/8	1 5/16	4.3	2B64SDS	SDS	A-2	11/16	1 5/16	7.1
6.95	6.20	6.60	1B66SDS	SDS	C-2	1/4	1 5/16	5.1	2B66SDS	SDS	A-2	11/16	1 5/16	7.6
7.15	6.40	6.80	1B68SDS	SDS	C-2	1/4	1 5/16	5.3	2B68SDS	SDS	A-2	11/16	1 5/16	7.8
7.35	6.60	7.00	1B70SDS	SDS	C-2	1/4	1 5/16	5.6	2B70SK	SK	D-2	7/16	1 15/16	9.5
7.75	7.00	7.40	1B74SDS	SDS	C-2	1/4	1 5/16	6.0	2B74SK	SK	D-2	7/16	1 15/16	10.2
8.35	7.60	8.00	1B80SDS	SDS	C-2	1/4	1 5/16	6.6	2B80SK	SK	D-2	7/16	1 15/16	10.8
8.95	8.20	8.60	1B86SDS	SDS	C-3	1/4	1 5/16	6.8	2B86SK	SK	D-3	7/16	1 15/16	11.7
9.35	8.60	9.00	1B90SDS	SDS	C-3	1/4	1 5/16	7.0	2B90SK	SK	D-3	7/16	1 15/16	13.0
9.75	9.00	9.40	1B94SDS	SDS	C-3	1/4	1 5/16	7.4	2B94SK	SK	D-3	7/16	1 15/16	13.2
11.35	10.60	11.00	1B110SDS	SDS	C-3	1/4	1 5/16	10.5	2B110SK	SK	D-3	7/16	1 15/16	16.4
12.75	12.00	12.40	1B124SDS	SDS	C-3	1/4	1 5/16	11.5	2B124SK	SK	D-3	7/16	1 15/16	18.3
13.95	13.20	13.60	1B136SDS	SDS	C-3	1/4	1 5/16	12.9	2B136SK	SK	D-3	7/16	1 15/16	20.3
15.75	15.00	15.40	1B154SK	SK	F-3	1/4	1 15/16	17.1	2B154SK	SK	D-3	7/16	1 15/16	23.8
16.35	15.60	16.00	1B160SK	SK	F-3	1/4	1 15/16	18.6	2B160SK	SK	D-3	7/16	1 15/16	24.3
18.75	18.00	18.40	1B184SK	SK	F-3	1/4	1 15/16	23.8	2B184SK	SK	D-3	7/16	1 15/16	31.8
20.35	19.60	20.00	1B200SK	SK	F-3	1/4	1 15/16	27.0	2B200SF	SF	D-3	3/8	2 1/16	33.4
25.35	24.60	25.00	1B250SF	SF	F-3	1/4	2 1/16	39.0	2B250SF	SF	D-3	3/8	2 1/16	45.0
30.35	29.60	30.00	1B300SF	SF	F-3	1/4	2 1/16	57.0	2B300SF	SF	D-3	3/8	2 1/16	71.2
38.35	37.60	38.00							2B380SF	SF	D-3	3/8	2 1/16	103.0

* = Can only be mounted from one direction.

+ = Includes cap screws to be used in place of the ones that come with the bushing.

Note: Cast iron sheaves may not exceed 6500 FPM. This speed **DOES NOT** specify if dynamic balancing (2 plane) is required. Contact customer service to verify whether dynamic balancing is required.

QD Bushing Sheaves

Cast Iron Sheaves - Heavy Duty
Bushed, Three and Four Groove
A-B QD Sheaves
Order part number size
Example: 3B34SH



For A, AX, B & BX V-Belts. See pages 102-108.
Order QD bushings separately.
Stock Bushings Located on Pages 84-85.

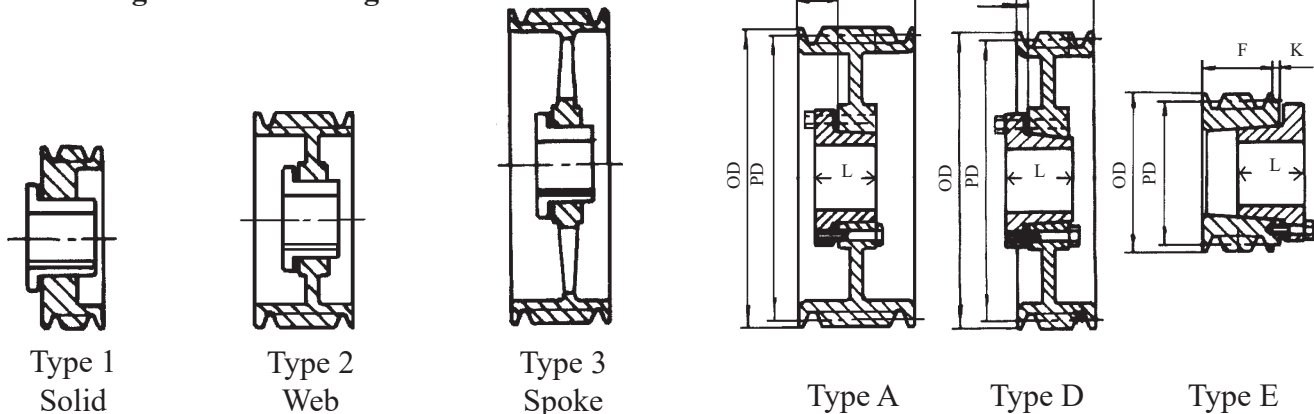

O.D.	P.D.		3 Groove F = 2 1/2					4 Groove F = 3 1/4						
	A	B	Part No.	Bush	Type	K	L	WT.	Part No.	Bush	Type	K	L	WT.
3.75	3.00	3.40	*3B34SH	SH	E-1	0	1 5/16	3.3	*+4B34SD	SD	E-1	5/16	1 13/16	4.3
3.95	3.20	3.60	*3B36SH	SH	D-1	3/16	1 5/16	3.6	*+4B36SD	SD	E-1	5/16	1 13/16	4.8
4.15	3.40	3.80	*3B38SH	SH	D-1	3/16	1 5/16	3.8	*+4B38SD	SD	E-1	5/16	1 13/16	5.2
4.35	3.60	4.00	+3B40SH	SH	A-1	1 1/16	1 5/16	4.2	*4B40SD	SD	E-1	0	1 13/16	5.6
4.55	3.80	4.20	+3B42SH	SH	A-1	1 1/16	1 5/16	4.8	*4B42SD	SD	E-1	0	1 13/16	6.2
4.75	4.00	4.40	3B44SH	SH	A-1	1 1/16	1 5/16	5.3	*4B44SD	SD	E-1	0	1 13/16	6.6
4.95	4.20	4.60	+3B46SD	SD	A-1	1 1/16	1 13/16	6.0	*4B46SD	SD	A-1	1 5/16	1 13/16	7.2
5.15	4.40	4.80	3B48SD	SD	A-1	1 1/16	1 13/16	6.5	4B48SD	SD	A-1	1 5/16	1 13/16	7.9
5.35	4.60	5.00	3B50SD	SD	A-1	1 1/16	1 13/16	7.2	4B50SD	SD	A-1	1 5/16	1 13/16	8.4
5.55	4.80	5.20	3B52SD	SD	A-1	1 1/16	1 13/16	7.8	4B52SD	SD	A-1	1 5/16	1 13/16	9.2
5.75	5.00	5.40	3B54SD	SD	A-1	1 1/16	1 13/16	8.4	4B54SD	SD	A-1	1 5/16	1 13/16	9.8
5.95	5.20	5.60	3B56SD	SD	A-1	1 1/16	1 13/16	9.0	4B56SD	SD	A-1	1 5/16	1 13/16	10.7
6.15	5.40	5.80	3B58SD	SD	A-1	1 1/16	1 13/16	9.7	4B58SD	SD	A-1	1 5/16	1 13/16	11.4
6.35	5.60	6.00	3B60SD	SD	A-1	1 1/16	1 13/16	8.9	4B60SD	SD	A-1	1 5/16	1 13/16	10.9
6.55	5.80	6.20	3B62SD	SD	A-2	1 1/16	1 13/16	9.4	4B62SD	SD	A-2	1 5/16	1 13/16	11.3
6.75	6.00	6.40	3B64SD	SD	A-2	1 1/16	1 13/16	9.7	4B64SD	SD	A-2	1 5/16	1 13/16	11.7
6.95	6.20	6.60	3B66SD	SD	A-2	1 1/16	1 13/16	10.0	4B66SD	SD	A-2	1 5/16	1 13/16	12.2
7.15	6.40	6.80	3B68SD	SD	A-2	1 1/16	1 13/16	11.1	4B68SD	SD	A-2	1 5/16	1 13/16	13.0
7.35	6.60	7.00	3B70SK	SK	A-2	1 1/16	1 15/16	11.4	4B70SK	SK	A-2	1	1 15/16	13.7
7.75	7.00	7.40	3B74SK	SK	A-2	1 1/16	1 15/16	12.5	4B74SK	SK	A-2	1	1 15/16	14.8
8.35	7.60	8.00	3B80SK	SK	A-2	1 1/16	1 15/16	13.6	4B80SK	SK	A-2	1	1 15/16	16.3
8.95	8.20	8.60	3B86SK	SK	A-3	1 1/16	1 15/16	14.6	4B86SK	SK	A-3	1	1 15/16	17.7
9.35	8.60	9.00	3B90SK	SK	A-3	1 1/16	1 15/16	15.9	4B90SK	SK	A-3	1	1 15/16	19.0
9.75	9.00	9.40	3B94SK	SK	A-3	1 1/16	1 15/16	16.6	4B94SK	SK	A-3	1	1 15/16	19.7
11.35	10.60	11.00	3B110SK	SK	A-3	1 1/16	1 15/16	20.8	4B110SK	SK	A-3	1	1 15/16	25.2
12.75	12.00	12.40	3B124SK	SK	A-3	1 1/16	1 15/16	22.5	4B124SK	SK	A-3	1	1 15/16	28.4
13.95	13.20	13.60	3B136SK	SK	A-3	1 1/16	1 15/16	25.3	4B136SK	SK	A-3	1	1 15/16	31.3
15.75	15.00	15.40	3B154SK	SK	A-3	1 1/16	1 15/16	29.8	4B154SF	SF	A-3	1	2 1/16	37.6
16.35	15.60	16.00	3B160SK	SK	A-3	1 1/16	1 15/16	30.3	4B160SF	SF	A-3	1	2 1/16	38.6
18.75	18.00	18.40	3B184SK	SK	A-3	1 1/16	1 15/16	39.1	4B184SF	SF	A-3	1	2 1/16	45.2
20.35	19.60	20.00	3B200SF	SF	D-3	5/8	2 1/16	43.0	4B200SF	SF	A-3	1	2 1/16	52.0
25.35	24.60	25.00	3B250SF	SF	D-3	5/8	2 1/16	56.0	4B250E	E	A-3	1	2 3/4	72.0
30.35	29.60	30.00	3B300SF	SF	D-3	5/8	2 1/16	77.0	4B300E	E	A-3	1	2 3/4	97.0
38.35	37.60	38.00	3B380E	E	D-3	5/8	2 3/4	115.0	4B380E	E	A-3	1	2 3/4	151.1

* = Can only be mounted from one direction.

+ = Includes cap screws to be used in place of the ones that come with the bushing.

Note: Cast iron sheaves may not exceed 6500 FPM. This speed **DOES NOT** specify if dynamic balancing (2 plane) is required. Contact customer service to verify whether dynamic balancing is required.

Cast Iron Sheaves - Heavy Duty
Bushed, Five and Six Groove
A-B QD Sheaves
Order part number size
Example: 5B34SD

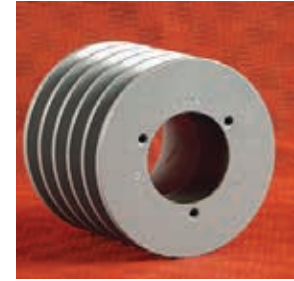

For A, AX, B & BX V-Belts. See pages 102-108.
Order QD bushings separately.
Stock Bushings Located on Pages 84-85.

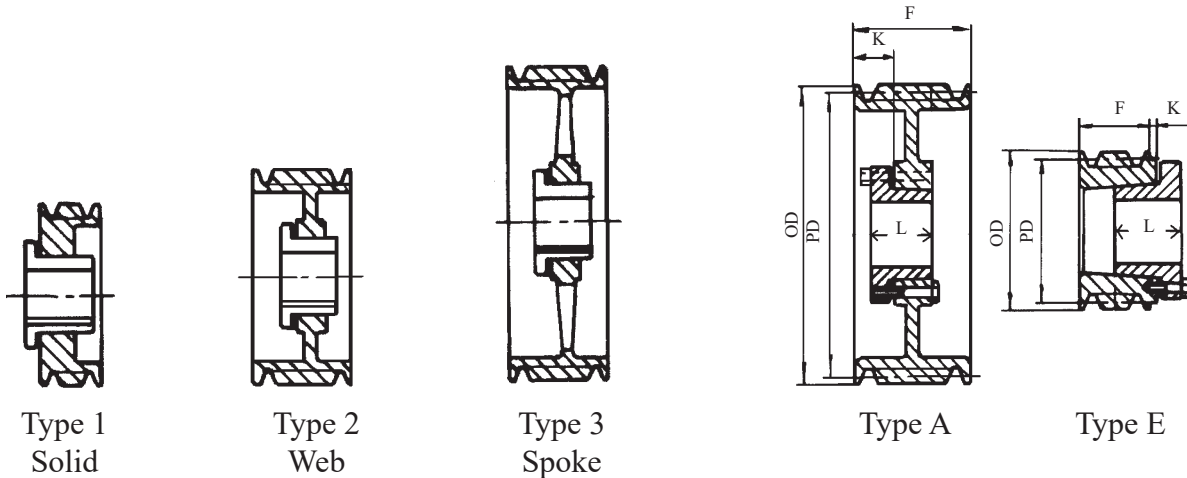

O.D.	P.D.		5 Groove F = 4						6 Groove F = 4 3/4					
	A	B	Part No.	Bush	Type	K	L	WT.	Part No.	Bush	Type	K	L	WT.
3.75	3.00	3.40	*+5B34SD	SD	E-1	5/16	1 13/16	5.2	*+6B34SD	SD	E-1	5/16	1 13/16	5.8
3.95	3.20	3.60	*+5B36SD	SD	E-1	5/16	1 13/16	5.7	*+6B36SD	SD	E-1	5/16	1 13/16	6.8
4.15	3.40	3.80	*5B38SD	SD	E-1	5/16	1 13/16	6.2	*6B38SD	SD	E-1	5/16	1 13/16	7.1
4.35	3.60	4.00	*5B40SD	SD	E-1	0	1 13/16	6.5	*6B40SD	SD	E-1	0	1 13/16	7.7
4.55	3.80	4.20	*5B42SD	SD	E-1	0	1 13/16	7.1	*6B42SD	SD	E-1	0	1 13/16	8.6
4.75	4.00	4.40	*5B44SD	SD	E-1	0	1 13/16	7.8	*6B44SD	SD	E-1	0	1 13/16	9.3
4.95	4.20	4.60	+5B46SD	SD	A-1	1 5/16	1 13/16	8.5	+6B46SD	SD	A-1	1 3/16	1 13/16	9.8
5.15	4.40	4.80	5B48SD	SD	A-1	1 5/16	1 13/16	9.2	6B48SD	SD	A-1	1 3/16	1 13/16	10.8
5.35	4.60	5.00	5B50SD	SD	A-1	1 5/16	1 13/16	9.9	6B50SD	SD	A-1	1 3/16	1 13/16	11.0
5.55	4.80	5.20	5B52SD	SD	A-1	1 5/16	1 13/16	10.9	6B52SD	SD	A-1	1 3/16	1 13/16	12.0
5.75	5.00	5.40	5B54SK	SK	A-1	1 5/16	1 15/16	10.5	6B54SK	SK	A-1	1 5/16	1 15/16	12.5
5.95	5.20	5.60	5B56SK	SK	A-1	1 5/16	1 15/16	11.4	6B56SK	SK	A-1	1 5/16	1 15/16	13.3
6.15	5.40	5.80	5B58SK	SK	A-1	1 5/16	1 15/16	12.3	6B58SK	SK	A-1	1 5/16	1 15/16	14.1
6.35	5.60	6.00	5B60SK	SK	A-1	1 5/16	1 15/16	12.8	6B60SK	SK	A-1	1 5/16	1 15/16	15.4
6.55	5.80	6.20	5B62SK	SK	A-1	1 5/16	1 15/16	13.6	6B62SK	SK	A-1	1 5/16	1 15/16	16.4
6.75	6.00	6.40	5B64SK	SK	A-1	1 5/16	1 15/16	14.6	6B64SK	SK	A-1	1 5/16	1 15/16	17.3
6.95	6.20	6.60	5B66SK	SK	A-1	1 5/16	1 15/16	15.9	6B66SK	SK	A-1	1 5/16	1 15/16	17.9
7.15	6.40	6.80	5B68SK	SK	A-1	1 5/16	1 15/16	16.7	6B68SK	SK	A-1	1 5/16	1 15/16	19.3
7.35	6.60	7.00	5B70SF	SF	A-1	1 5/16	2 1/16	17.1	6B70SF	SF	A-1	1 11/16	2 1/16	19.8
7.75	7.00	7.40	5B74SF	SF	A-1	1 5/16	2 1/16	18.7	6B74SF	SF	A-2	1 11/16	2 1/16	22.4
8.35	7.60	8.00	5B80SF	SF	A-2	1 5/16	2 1/16	19.3	6B80SF	SF	A-2	1 11/16	2 1/16	25.4
8.95	8.20	8.60	5B86SF	SF	A-2	1 5/16	2 1/16	21.6	6B86SF	SF	A-2	1 11/16	2 1/16	25.7
9.75	9.00	9.40	5B94SF	SF	A-2	1 5/16	2 1/16	24.0	6B94SF	SF	A-2	1 11/16	2 1/16	27.9
11.35	10.60	11.00	5B110SF	SF	A-3	1 5/16	2 1/16	28.7	6B110SF	SF	A-3	1 11/16	2 1/16	33.1
12.75	12.00	12.40	5B124SF	SF	A-3	1 5/16	2 1/16	33.8	6B124SF	SF	A-3	1 11/16	2 1/16	37.5
13.95	13.20	13.60	5B136SF	SF	A-3	1 5/16	2 1/16	37.0	6B136SF	SF	A-3	1 11/16	2 1/16	42.0
15.75	15.00	15.40	5B154SF	SF	A-3	1 5/16	2 1/16	43.0	6B154SF	SF	A-3	1 11/16	2 1/16	49.0
16.35	15.60	16.00	5B160SF	SF	A-3	1 5/16	2 1/16	48.0	6B160SF	SF	A-3	1 11/16	2 1/16	48.8
18.75	18.00	18.40	5B184SF	SF	A-3	1 5/16	2 1/16	51.8	6B184SF	SF	A-3	1 11/16	2 1/16	60.0
20.35	19.60	20.00	5B200E	E	A-3	1 1/4	2 3/4	62.0	6B200E	E	A-3	1 3/8	2 3/4	72.0
25.35	24.60	25.00	5B250E	E	A-3	1 1/4	2 3/4	85.0	6B250E	E	A-3	1 3/8	2 3/4	94.0
30.35	29.60	30.00	5B300E	E	A-3	1 1/4	2 3/4	85.0	6B300E	E	A-3	1 3/8	2 3/4	131.0
38.35	37.60	38.00	5B380E	E	A-3	1 1/4	2 3/4	159.0	6B380E	E	A-3	1 3/8	2 3/4	183.0

* = Can only be mounted from one direction.

+ = Includes cap screws to be used in place of the ones that come with the bushing.

Note: Cast iron sheaves may not exceed 6500 FPM. This speed **DOES NOT** specify if dynamic balancing (2 plane) is required.

Contact customer service to verify whether dynamic balancing is required.

QD Bushing Sheaves

Cast Iron Sheaves
Bushed, Seven and Eight Groove
A-B QD Sheaves
Order part number size
Example: 7B54SK

For A, AX, B & BX V-Belts. See pages 102-108.
Order QD bushings separately.
Stock Bushings Located on Pages 84-85.

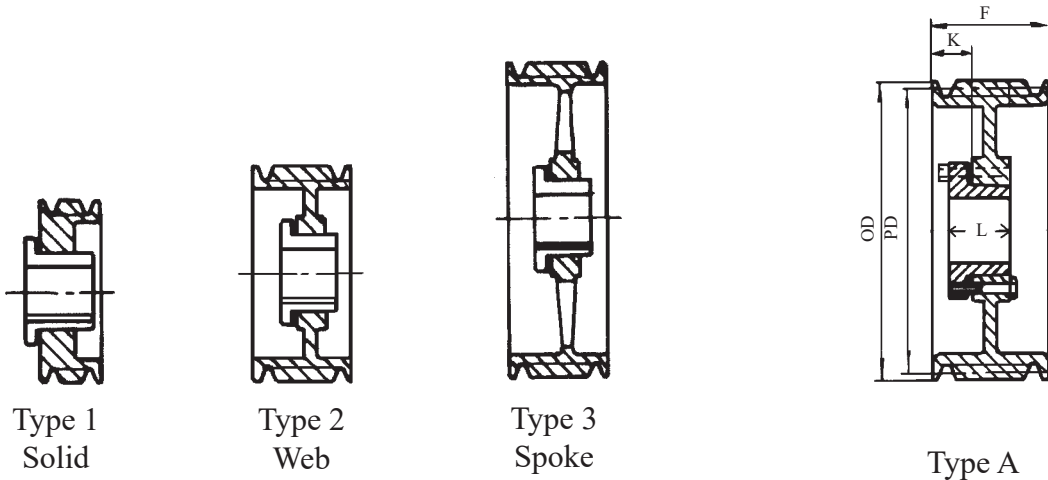

O.D.	P.D.		7 Groove F = 5 1/2						8 Groove F = 6 1/4					
	A	B	Part No.	Bush	Type	K	L	WT.	Part No.	Bush	Type	K	L	WT.
5.75	5.00	5.40	7B54SK	SK	A-1	1 13/16	1 15/16	12.5	8B54SK	SK	A-1	1 13/16	1 15/16	15.5
5.95	5.20	5.60	7B56SK	SK	A-1	1 13/16	1 15/16	13.6	8B56SK	SK	A-1	1 13/16	1 15/16	16.6
6.15	5.40	5.80	7B58SK	SK	A-1	1 13/16	1 15/16	14.1	8B58SK	SK	A-1	1 13/16	1 15/16	17.1
6.35	5.60	6.00	7B60SK	SK	A-1	1 13/16	1 15/16	15.7	8B60SK	SK	A-1	1 13/16	1 15/16	18.7
6.55	5.80	6.20	7B62SF	SF	A-1	1 13/16	2 1/16	16.3	8B62SF	SF	A-1	1 13/16	2 1/16	19.3
6.75	6.00	6.40	7B64SF	SF	A-1	1 13/16	2 1/16	17.3	8B64SF	SF	A-1	1 13/16	2 1/16	20.3
6.95	6.20	6.60	7B66SF	SF	A-1	1 13/16	2 1/16	18.3	8B66SF	SF	A-1	1 13/16	2 1/16	21.3
7.15	6.40	6.80	7B68SF	SF	A-1	1 13/16	2 1/16	19.9	8B68SF	SF	A-1	1 13/16	2 1/16	22.9
7.35	6.60	7.00	7B70SF	SF	A-1	1 13/16	2 1/16	21.7	8B70SF	SF	A-1	1 13/16	2 1/16	24.7
7.75	7.00	7.40	7B74SF	SF	A-1	1 13/16	2 1/16	23.5	8B74SF	SF	A-1	1 13/16	2 1/16	26.5
8.95	8.20	8.60	7B86E	E	A-1	2 3/8	2 3/4	32.3	8B86E	E	A-1	2 3/8	2 3/4	35.3
9.75	9.00	9.40	7B94E	E	A-1	2 3/8	2 3/4	37.9	8B94E	E	A-1	2 3/8	2 3/4	41.9
11.35	10.60	11.00	7B110E	E	A-2	2 3/8	2 3/4	41.9	8B110E	E	A-2	2 3/8	2 3/4	44.9
12.75	12.00	12.40	7B124E	E	A-3	2 3/8	2 3/4	49.0	8B124E	E	A-3	2 3/8	2 3/4	52.0
13.95	13.20	13.60	7B136E	E	A-3	2 3/8	2 3/4	52.0	8B136E	E	A-3	2 3/8	2 3/4	55.0
15.75	15.00	15.40	7B154E	E	A-3	2 3/8	2 3/4	59.0	8B154E	E	A-3	2 3/8	2 3/4	61.0
16.35	15.60	16.00	7B160E	E	A-3	2 3/8	2 3/4	62.0	8B160E	E	A-3	2 3/8	2 3/4	64.0
18.75	18.00	18.40	7B184F	F	A-3	1 5/16	3 3/4	80.0	8B184F	F	A-3	1 5/16	3 3/4	82.0
20.35	19.60	20.00							8B200F	F	A-3	1 5/16	3 3/4	93.0
25.35	24.60	25.00							8B250F	F	A-3	1 5/16	3 3/4	116.0
30.35	29.60	30.00							8B300F	F	A-3	1 5/16	3 3/4	157.0
38.35	37.60	38.00							8B380F	F	A-3	1 5/16	3 3/4	216.0

Note: Cast iron sheaves may not exceed 6500 FPM.
This speed **DOES NOT** specify if dynamic balancing
(2 plane) is required. Contact customer service to
verify whether dynamic balancing is required.

Cast Iron Sheaves
Bushed, **Ten Groove**
A-B QD Sheaves
Order part number size
Example: 10B54SK

For A, AX, B & BX V-Belts. See pages 102-108.
Order QD bushings separately.
Stock Bushings Located on Pages 84-85.

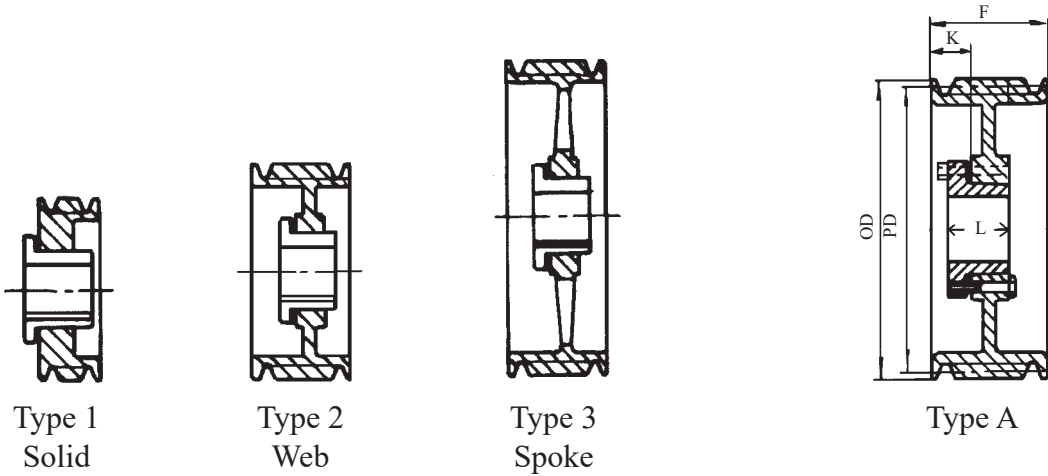

O.D.	P.D.		10 Groove F = 7 3/4					WT.
	A	B		Bush	Type	K	L	
5.75	5.00	5.40	10B54SK	SK	A-1	2 9/16	1 15/16	18.5
5.95	5.20	5.60	10B56SK	SK	A-1	2 9/16	1 15/16	19.8
6.15	5.40	5.80	10B58SK	SK	A-1	2 9/16	1 15/16	21.2
6.35	5.60	6.00	10B60SK	SK	A-1	2 9/16	1 15/16	22.3
6.55	5.80	6.20	10B62SF	SF	A-1	2 9/16	2 1/16	22.8
6.75	6.00	6.40	10B64SF	SF	A-1	2 9/16	2 1/16	24.2
6.95	6.20	6.60	10B66SF	SF	A-1	2 9/16	2 1/16	25.6
7.15	6.40	6.80	10B68SF	SF	A-1	2 9/16	2 1/16	26.8
7.35	6.60	7.00	10B70SF	SF	A-1	2 9/16	2 1/16	28.3
7.75	7.00	7.40	10B74SF	SF	A-1	2 9/16	2 1/16	31.4
8.95	8.20	8.60	10B86E	E	A-1	3 1/8	2 3/4	41.0
9.75	9.00	9.40	10B94E	E	A-2	3 1/8	2 3/4	47.8
11.35	10.60	11.00	10B110E	E	A-2	3 1/8	2 3/4	58.0
12.75	12.00	12.40	10B124E	E	A-3	3 1/8	2 3/4	65.0
13.95	13.20	13.60	10B136F	F	A-3	2 1/16	3 3/4	80.0
15.75	15.00	15.40	10B154F	F	A-3	2 1/16	3 3/4	87.0
16.35	15.60	16.00	10B160F	F	A-3	2 1/16	3 3/4	89.0
18.75	18.00	18.40	10B184F	F	A-3	2 1/16	3 3/4	102.0
20.35	19.60	20.00	10B200F	F	A-3	2 1/16	3 3/4	112.0
25.35	24.60	25.00	10B250F	F	A-3	2 1/16	3 3/4	148.0
30.35	29.60	30.00	10B300F	F	A-3	2 1/16	3 3/4	188.0
38.35	37.60	38.00	10B380J	J	A-3	1 9/16	4 5/8	291.0

Note: Cast iron sheaves may not exceed 6500 FPM.
This speed **DOES NOT** specify if dynamic balancing
(2 plane) is required. Contact customer service to
verify whether dynamic balancing is required.

QD Bushing Sheaves

Cast Iron Sheaves
Bushed, **One and Two Groove**
C QD Sheaves
Order part number size
Example: 1C60SK



For C & CX V-Belts. See pages 109-112.
Order QD bushings separately.
Stock Bushings Located on Pages 84-85.

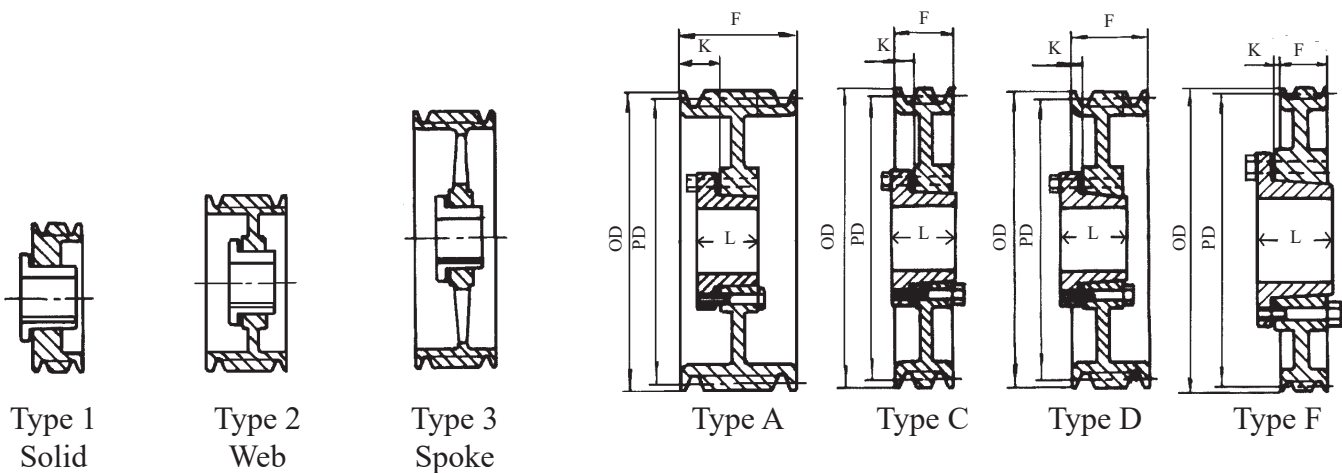

Diameters		1 Groove F = 1 3/8						2 Groove F = 2 3/8					
O.D.	P.D.	Part No.	Bush	Type	K	L	WT.	Part No.	Bush	Type	K	L	WT.
6.40	6.00	1C60SK	SK	C-1	1/8	1 15/16	8.7	2C60SF	SF	A-1	7/8	2 1/16	11.4
7.40	7.00	1C70SF	SF	C-1	1/8	2 1/16	9.7	2C70SF	SF	A-1	13/16	2 1/16	12.4
7.90	7.50	1C75SF	SF	C-1	1/8	2 1/16	11.4	2C75SF	SF	A-1	13/16	2 1/16	14.4
8.40	8.00	1C80SF	SF	C-1	1/8	2 1/16	13.0	2C80SF	SF	A-1	13/16	2 1/16	16.3
8.90	8.50	1C85SF	SF	C-2	1/8	2 1/16	12.6	2C85SF	SF	A-2	13/16	2 1/16	16.6
9.40	9.00	1C90SF	SF	C-2	1/8	2 1/16	12.8	2C90SF	SF	A-2	13/16	2 1/16	17.3
9.90	9.50	1C95SF	SF	C-2	1/8	2 1/16	13.3	2C95SF	SF	A-2	13/16	2 1/16	18.1
10.40	10.00	1C100SF	SF	C-2	1/8	2 1/16	14.2	2C100SF	SF	A-2	13/16	2 1/16	19.4
10.90	10.50	1C105SF	SF	C-3	1/8	2 1/16	15.2	2C105SF	SF	A-3	13/16	2 1/16	20.6
11.40	11.00	1C110SF	SF	C-3	1/8	2 1/16	16.2	2C110SF	SF	A-3	13/16	2 1/16	22.0
12.40	12.00	1C120SF	SF	C-3	1/8	2 1/16	18.6	2C120SF	SF	D-3	9/16	2 1/16	24.2
13.40	13.00	1C130SF	SF	C-3	1/8	2 1/16	19.1	2C130SF	SF	D-3	9/16	2 1/16	27.8
14.40	14.00	1C140SF	SF	C-3	1/8	2 1/16	20.3	2C140SF	SF	D-3	9/16	2 1/16	30.1
15.40	15.00	1C150SF	SF	C-3	1/8	2 1/16	22.0	2C150SF	SF	D-3	9/16	2 1/16	32.0
16.40	16.00	1C160SF	SF	C-3	1/8	2 1/16	23.5	2C160SF	SF	D-3	9/16	2 1/16	34.9
18.40	18.00	1C180SF	SF	C-3	1/8	2 1/16	27.8	2C180SF	SF	D-3	9/16	2 1/16	40.9
20.40	20.00	1C200SF	SF	C-3	1/8	2 1/16	31.8	2C200SF	SF	D-3	9/16	2 1/16	42.1
24.40	24.00	1C240SF	SF	C-3	1/8	2 1/16	41.2	2C240SF	SF	D-3	9/16	2 1/16	56.7
27.40	27.00							2C270F	F	F-3	1/8	3 3/4	79.4
30.40	30.00							2C300F	F	F-3	1/8	3 3/4	82.4

Note: Cast iron sheaves may not exceed 6500 FPM.
This speed **DOES NOT** specify if dynamic balancing
(2 plane) is required. Contact customer service to
verify whether dynamic balancing is required.

Cast Iron Sheaves - **Heavy Duty**
Bushed, **Three and Four Groove**
C QD Sheaves
Order part number size
Example: 3C50SD



For C & CX V-Belts. See pages 109-112.
Order QD bushings separately.
Stock Bushings Located on Pages 84-85.

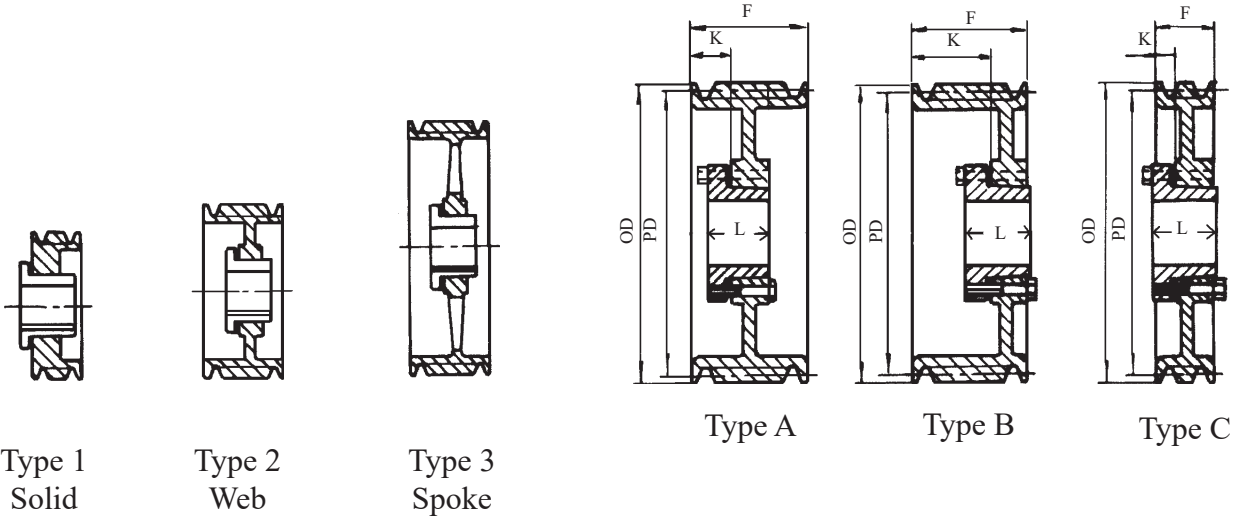

Diameters		3 Groove F = 3 3/8						4 Groove F = 4 3/8					
O.D.	P.D.	Part No.	Bushing#	Type	K	L	WT.	Part No.	Bushing#	Type	K	L	WT.
5.40	5.00	3C50SD	SD	A-1	1 1/4	1 13/16	8.4	4C50SD	SD	A-1	1 1/4	1 13/16	10.2
5.40	5.00	^3C50SK	SK	A-1	0	1 15/16	8.4	^4C50SK	SK	A-1	0	1 15/16	10.2
5.80	5.40	3C54SD	SD	A-1	1 5/16	1 13/16	10.4	4C54SD	SD	A-1	1 5/16	1 13/16	11.8
5.90	5.50	3C55SD	SD	A-1	1 5/16	1 13/16	10.9	4C55SD	SD	A-1	1 5/16	1 13/16	13.5
5.90	5.50							^4C55SK	SK	A-1	0	1 15/16	13.0
6.00	5.60	3C56SD	SD	A-1	1 5/16	1 13/16	11.2	4C56SD	SD	A-1	1 5/16	1 13/16	13.9
6.40	6.00	3C60SF	SF	A-1	7/8	2 1/16	10.1	4C60SF	SF	A-1	7/8	2 1/16	12.0
6.90	6.50	*3C65SF	SF	A-1	0	2 1/16	10.8	*4C65SF	SF	A-1	13/16	2 1/16	12.2
7.40	7.00	3C70SF	SF	A-1	1 5/16	2 1/16	15.9	4C70SF	SF	A-1	1 9/16	2 1/16	18.0
7.90	7.50	3C75SF	SF	A-1	1 5/16	2 1/16	18.0	4C75SF	SF	A-1	1 9/16	2 1/16	20.5
8.40	8.00	3C80E	E	B-1	1 3/4	2 3/4	20.9	4C80E	E	A-1	2	2 3/4	24.0
8.90	8.50	3C85E	E	B-1	1 3/4	2 3/4	24.5	4C85E	E	A-1	2	2 3/4	27.3
9.40	9.00	3C90E	E	B-1	1 3/4	2 3/4	27.1	4C90E	E	A-1	2	2 3/4	30.7
9.90	9.50	3C95E	E	B-1	1 3/4	2 3/4	29.1	4C95E	E	A-1	2	2 3/4	34.9
10.40	10.00	3C100E	E	B-2	1 3/4	2 3/4	30.1	4C100E	E	A-2	2	2 3/4	38.1
10.90	10.50	3C105E	E	B-2	1 3/4	2 3/4	30.8	4C105E	E	A-2	2	2 3/4	35.8
11.40	11.00	3C110E	E	B-3	1 3/4	2 3/4	32.9	4C110E	E	A-3	2	2 3/4	38.4
12.40	12.00	3C120E	E	B-3	1 3/4	2 3/4	38.4	4C120E	E	A-3	2	2 3/4	43.6
13.40	13.00	3C130E	E	B-3	1 3/4	2 3/4	42.4	4C130E	E	A-3	2	2 3/4	49.4
14.40	14.00	3C140E	E	B-3	1 3/4	2 3/4	41.7	4C140E	E	A-3	2	2 3/4	50.7
15.40	15.00	3C150E	E	B-3	1 3/4	2 3/4	45.0	4C150E	E	A-3	2	2 3/4	52.0
16.40	16.00	3C160E	E	B-3	1 3/4	2 3/4	49.8	4C160E	E	A-3	2	2 3/4	60.2
18.40	18.00	3C180E	E	B-3	1 3/4	2 3/4	58.6	4C180E	E	A-3	2	2 3/4	68.6
20.40	20.00	3C200E	E	A-3	1	2 3/4	62.6	4C200E	E	A-3	1 1/2	2 3/4	76.9
24.40	24.00	3C240E	E	A-3	1	2 3/4	78.7	4C240F	F	A-3	1 5/16	3 3/4	100.4
27.40	27.00	3C270F	F	C-3	7/8	3 3/4	103.0	4C270F	F	A-3	1 5/16	3 3/4	116.8
30.40	30.00	3C300F	F	C-3	7/8	3 3/4	115.4	4C300F	F	A-3	1 5/16	3 3/4	136.1
36.40	36.00	3C360F	F	C-3	7/8	3 3/4	161.7	4C360F	F	A-3	1 5/16	3 3/4	194.2
44.40	44.00	3C440F	F	C-3	13/16	3 3/4	242.8	4C440J	J	A-3	1 9/16	4 5/8	270.4
50.40	50.00	3C500F	F	C-3	13/16	3 3/4	275.0	4C500J	J	A-3	1 9/16	4 5/8	337.4

Note: Cast iron sheaves may not exceed 6500 FPM.
This speed **DOES NOT** specify if dynamic balancing (2 plane) is required. Contact customer service to verify whether dynamic balancing is required.

* = Can only be mounted from one direction.
^ = Small O.D. sheaves used heavily in the oil industry. **25**
Can only be mounted from one direction.

QD Bushing Sheaves

Cast Iron Sheaves - **Heavy Duty**
Bushed, **Five and Six Groove**
C QD Sheaves
Order part number size
Example: 5C60SF

For C & CX V-Belts. See pages 109-112.
Order QD bushings separately.
Stock Bushings Located on Pages 84-85.

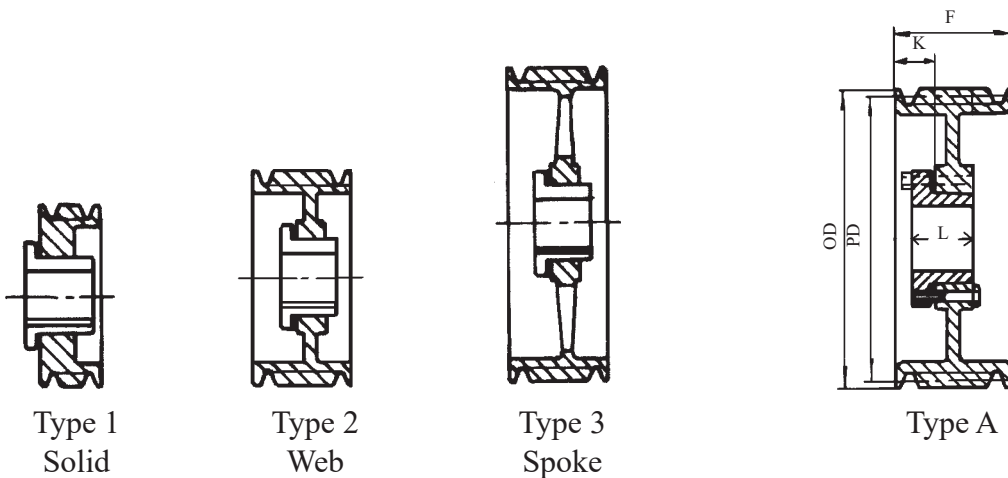

Diameters		5 Groove F = 5 3/8						6 Groove F = 6 3/8					
O.D.	P.D.	Part No.	Bush	Type	K	L	WT.	Part No.	Bush	Type	K	L	WT.
5.40	5.00	[^] 5C50SK	SK	A-1	7/8	1 15/16	10.0	[^] 6C50SK	SK	A-1	7/8	1 15/16	11.0
6.40	6.00	5C60SF	SF	A-1	7/8	2 1/16	12.5	6C60SF	SF	A-1	7/8	2 1/16	14.0
7.40	7.00	5C70SF	SF	A-1	1 15/16	2 1/16	20.8	6C70SF	SF	A-1	1 15/16	2 1/16	23.6
7.90	7.50	5C75SF	SF	A-1	1 15/16	2 1/16	23.6	6C75SF	SF	A-1	1 15/16	2 1/16	26.6
8.40	8.00	5C80E	E	A-1	2 3/8	2 3/4	27.3	6C80E	E	A-1	2 3/8	2 3/4	30.6
8.90	8.50	5C85E	E	A-1	2 3/8	2 3/4	30.8	6C85E	E	A-1	2 3/8	2 3/4	34.4
9.40	9.00	5C90E	E	A-1	2 3/8	2 3/4	34.5	6C90F	F	A-1	1 7/16	3 3/4	43.0
9.90	9.50	5C95E	E	A-1	2 3/8	2 3/4	39.1	6C95F	F	A-1	1 7/16	3 3/4	49.1
10.40	10.00	5C100E	E	A-2	2 3/8	2 3/4	42.4	6C100F	F	A-1	1 7/16	3 3/4	54.0
10.90	10.50	5C105E	E	A-2	2 3/8	2 3/4	40.4	6C105F	F	A-1	1 7/16	3 3/4	60.0
11.40	11.00	5C110E	E	A-3	2 3/8	2 3/4	43.1	6C110F	F	A-2	1 7/16	3 3/4	66.2
12.40	12.00	5C120E	E	A-3	2 3/8	2 3/4	48.8	6C120F	F	A-2	1 7/16	3 3/4	62.5
13.40	13.00	5C130E	E	A-3	2 3/8	2 3/4	55.1	6C130F	F	A-3	1 7/16	3 3/4	70.0
14.40	14.00	5C140E	E	A-3	2 3/8	2 3/4	57.2	6C140F	F	A-3	1 7/16	3 3/4	73.0
15.40	15.00	5C150E	E	A-3	2 3/8	2 3/4	68.2	6C150F	F	A-3	1 7/16	3 3/4	75.0
16.40	16.00	5C160E	E	A-3	2 3/8	2 3/4	71.2	6C160F	F	A-3	1 7/16	3 3/4	87.7
18.40	18.00	5C180E	E	A-3	2 3/8	2 3/4	79.1	6C180F	F	A-3	1 7/16	3 3/4	98.3
20.40	20.00	5C200F	F	A-3	1 5/16	3 3/4	96.5	6C200F	F	A-3	1 15/16	3 3/4	109.8
24.40	24.00	5C240F	F	A-3	1 5/16	3 3/4	106.7	6C240F	F	A-3	1 15/16	3 3/4	122.1
27.40	27.00	5C270F	F	A-3	1 5/16	3 3/4	129.2	6C270J	J	A-3	1 9/16	4 5/8	158.8
30.40	30.00	5C300F	F	A-3	1 5/16	3 3/4	160.8	6C300J	J	A-3	1 9/16	4 5/8	192.8
36.40	36.00	5C360J	J	A-3	1 9/16	4 5/8	220.3	6C360J	J	A-3	1 9/16	4 5/8	254.5
44.40	44.00	5C440J	J	A-3	1 9/16	4 5/8	293.2	6C440J	J	A-3	1 9/16	4 5/8	315.0
50.40	50.00	5C500J	J	A-3	1 9/16	4 5/8	275.0	6C500M	M	A-3	1 15/16	6 3/4	325.0

Note: Cast iron sheaves may not exceed 6500 FPM. This speed **DOES NOT** specify if dynamic balancing (2 plane) is required. Contact customer service to verify whether dynamic balancing is required.

[^] = Small O.D. sheaves used heavily in the oil industry.

Cast Iron Sheaves - Heavy Duty
Bushed, Seven and Eight Groove
C QD Sheaves
Order part number size
Example: 7C70SF

For C & CX V-Belts. See pages 109-112.
Order QD bushings separately.
Stock Bushings Located on Pages 84-85.

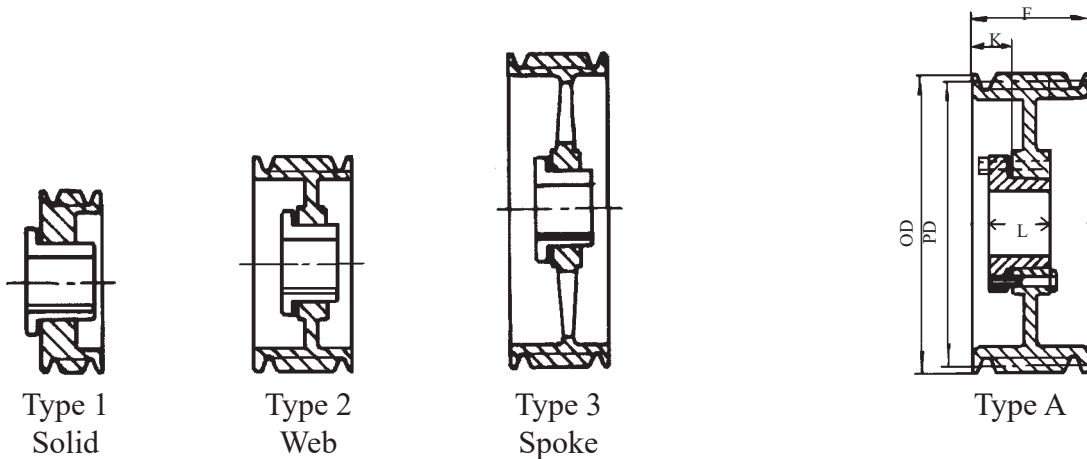

Diameters		7 Groove F = 7 3/8						8 Groove F = 8 3/8					
O.D.	P.D.	Part No.	Bush	Type	K	L	WT.	Part No.	Bush	Type	K	L	WT.
7.40	7.00	7C70SF	SF	A-1	3 1/8	2 1/16	26.2	8C70SF	SF	A-1	3 1/8	2 1/16	29.2
8.40	8.00	7C80E	E	A-1	3 1/4	2 3/4	34.3	8C80E	E	A-1	3 1/4	2 3/4	37.3
8.90	8.50	7C85E	E	A-1	3 1/4	2 3/4	38.5	8C85E	E	A-1	3 1/4	2 3/4	41.5
9.40	9.00	7C90F	F	A-1	3 5/16	3 3/4	47.5	8C90F	F	A-1	3 5/16	3 3/4	50.5
9.90	9.50	7C95F	F	A-1	3 5/16	3 3/4	54.6	8C95F	F	A-1	3 5/16	3 3/4	57.6
10.40	10.00	7C100F	F	A-1	3 5/16	3 3/4	59.6	8C100F	F	A-1	3 5/16	3 3/4	62.6
10.90	10.50	7C105F	F	A-1	3 5/16	3 3/4	66.0	8C105F	F	A-1	3 5/16	3 3/4	69.0
11.40	11.00	7C110F	F	A-1	3 5/16	3 3/4	72.6	8C110F	F	A-1	3 5/16	3 3/4	75.6
12.40	12.00	7C120F	F	A-2	3 5/16	3 3/4	69.9	8C120F	F	A-2	3 5/16	3 3/4	72.9
13.40	13.00	7C130F	F	A-2	3 5/16	3 3/4	78.3	8C130F	F	A-2	3 5/16	3 3/4	81.3
14.40	14.00	7C140F	F	A-2	3 5/16	3 3/4	85.0	8C140F	F	A-2	3 5/16	3 3/4	88.0
15.40	15.00	7C150F	F	A-2	3 5/16	3 3/4	103.0	8C150F	F	A-2	3 5/16	3 3/4	105.0
16.40	16.00	7C160F	F	A-3	3 5/16	3 3/4	107.0	8C160F	F	A-3	3 5/16	3 3/4	108.6
18.40	18.00	7C180F	F	A-3	3 5/16	3 3/4	121.0	8C180F	F	A-3	3 5/16	3 3/4	123.3
20.40	20.00							8C200J	J	A-3	1 9/16	4 5/8	146.5
24.40	24.00							8C240J	J	A-3	1 9/16	4 5/8	173.4
27.40	27.00							8C270J	J	A-3	1 9/16	4 5/8	226.3
30.40	30.00							8C300J	J	A-3	1 9/16	4 5/8	240.0
36.40	36.00							8C360M	M	A-3	1 15/16	6 3/4	355.3
44.40	44.00							8C440M	M	C-3	1 15/16	6 3/4	452.0
50.40	50.00							8C500M	M	C-3	1 15/16	6 3/4	546.1

Note: Cast iron sheaves may not exceed 6500 FPM.
This speed **DOES NOT** specify if dynamic balancing
(2 plane) is required. Contact customer service to
verify whether dynamic balancing is required.

QD Bushing Sheaves

Cast Iron Sheaves - Heavy Duty
Bushed, Ten Groove
C QD Sheaves
Order part number size
Example: 10C80E

For C & CX V-Belts. See pages 109-112.
Order QD bushings separately.
Stock Bushings Located on Pages 84-85.

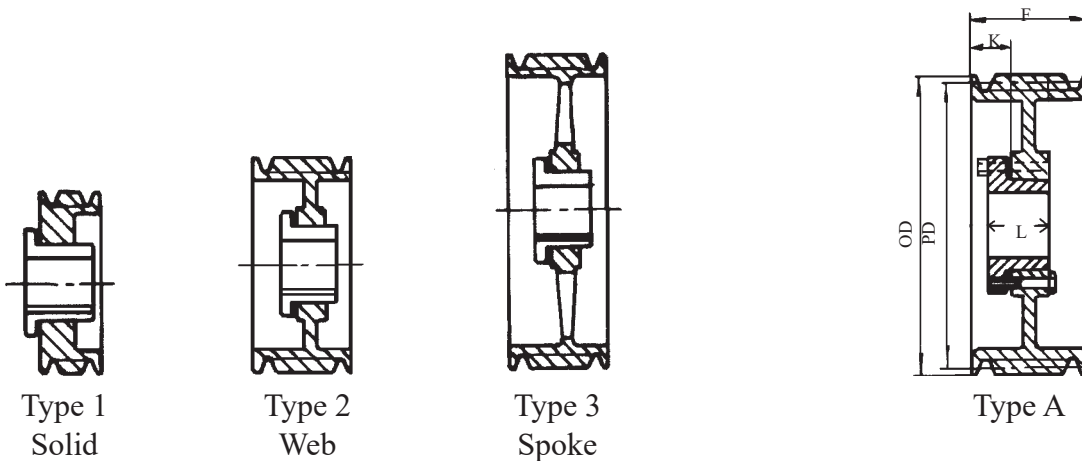

Diameters		10 Groove F = 10 3/8					
O.D.	P.D.	Part No.	Bush	Type	K	L	WT.
8.40	8.00	10C80E	E	A-1	3 1/4	2 3/4	43.9
8.90	8.50	10C85E	E	A-1	3 1/4	2 3/4	48.6
9.40	9.00	+10C90J	J	A-1	3 9/16	4 5/8	59.6
9.90	9.50	+10C95J	J	A-1	3 9/16	4 5/8	67.8
10.40	10.00	10C100J	J	A-1	3 9/16	4 5/8	74.1
10.90	10.50	10C105J	J	A-1	3 9/16	4 5/8	82.2
11.40	11.00	10C110J	J	A-1	3 9/16	4 5/8	90.6
12.40	12.00	10C120J	J	A-1	3 9/16	4 5/8	108.4
13.40	13.00	10C130J	J	A-2	3 9/16	4 5/8	136.0
14.40	14.00	10C140J	J	A-2	3 9/16	4 5/8	110.8
16.40	16.00	10C160J	J	A-3	3 9/16	4 5/8	141.3
18.40	18.00	10C180J	J	A-3	3 9/16	4 5/8	148.7
20.40	20.00	10C200J	J	A-3	3 9/16	4 5/8	169.7
24.40	24.00	10C240M	M	A-3	3 9/16	6 3/4	263.1
30.40	30.00	10C300M	M	A-3	1 15/16	6 3/4	332.1
36.40	36.00	10C360M	M	A-3	1 15/16	6 3/4	397.5
44.40	44.00	10C440M	M	A-3	1 15/16	6 3/4	531.8
50.40	50.00	10C500M	M	A-3	1 15/16	6 3/4	600.0

+ = Includes cap screws to be used in place of the ones that come with the bushing.

Note: Cast iron sheaves may not exceed 6500 FPM. This speed **DOES NOT** specify if dynamic balancing (2 plane) is required. Contact customer service to verify whether dynamic balancing is required.

Cast Iron Sheaves - Heavy Duty

Bushed, **One and Two Groove**

3V QD Sheaves

Order part number size

Example: 1/3V220JA

For 3V & 3VX Belts. See pages 113-114.

Order QD bushings separately.

Stock Bushings Located on Pages 84-85.

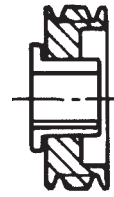

Type 1
Solid

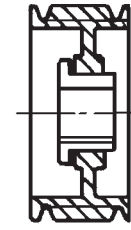

Type 2
Web

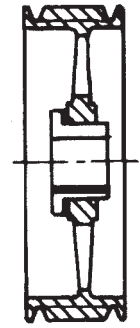

Type 3
Spoke

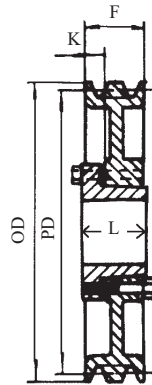

Type C

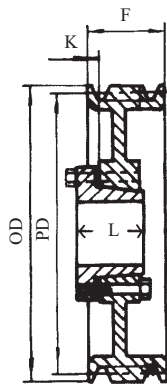

Type D

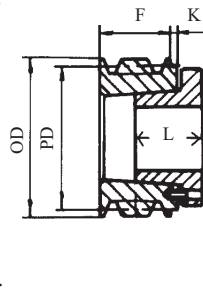

Type E

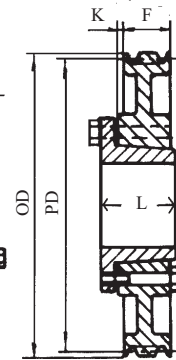

Type F

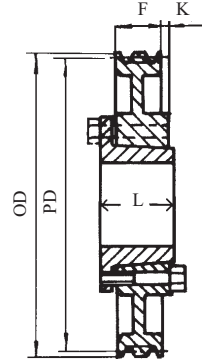

Type G

Diameters		1 Groove F = 11/16						2 Groove F = 1 3/32					
O.D.	P.D.	Part No.	Bush	Type	K	L	WT.	Part No.	Bush	Type	K	L	WT.
2.20	2.15	*1/3V220JA	JA	E-1	7/16	1	.7	*2/3V220JA	JA	E-1	7/16	1	.9
2.35	2.30	*1/3V235JA	JA	E-1	7/16	1	.7	*2/3V235JA	JA	E-1	7/16	1	.9
2.50	2.45	*1/3V250JA	JA	E-1	7/16	1	.8	*2/3V250JA	JA	E-1	7/16	1	1.0
2.65	2.60	*1/3V265JA	JA	C-1	1/8	1	.6	*2/3V265JA	JA	D-1	1/8	1	.8
2.80	2.75	1/3V280JA	JA	C-1	1/8	1	.6	*2/3V280JA	JA	D-1	1/8	1	1.0
3.00	2.95	1/3V300JA	JA	C-1	1/8	1	.8	*2/3V300JA	JA	D-1	1/8	1	1.1
3.15	3.10	1/3V315JA	JA	C-1	1/8	1	.9	2/3V315JA	JA	D-1	1/8	1	1.2
3.35	3.30	1/3V335JA	JA	C-1	1/8	1	1.1	*2/3V335SH	SH	D-1	9/64	1 5/16	1.2
3.65	3.60	1/3V365SH	SH	G-1	1/8	1 5/16	1.3	2/3V365SH	SH	D-1	9/64	1 5/16	1.7
4.12	4.07	1/3V412SH	SH	G-1	1/8	1 5/16	1.8	2/3V412SH	SH	D-1	9/32	1 5/16	2.3
4.50	4.45	1/3V450SH	SH	G-1	1/8	1 5/16	2.2	2/3V450SH	SH	D-1	9/32	1 5/16	2.8
4.75	4.70	1/3V475SH	SH	G-1	1/8	1 5/16	2.1	2/3V475SH	SH	D-1	9/32	1 5/16	2.6
5.00	4.95	1/3V500SH	SH	G-1	1/8	1 5/16	2.3	2/3V500SH	SH	D-1	9/32	1 5/16	2.9
5.30	5.25	1/3V530SH	SH	G-2	1/8	1 5/16	3.0	2/3V530SH	SH	D-1	9/32	1 5/16	3.1
5.60	5.55	1/3V560SH	SH	G-2	1/8	1 5/16	2.8	2/3V560SH	SH	D-2	9/32	1 5/16	3.4
6.00	5.95	1/3V600SH	SH	G-2	1/8	1 5/16	3.7	2/3V600SH	SH	D-2	9/32	1 5/16	3.8
6.50	6.45	1/3V650SH	SH	G-2	1/8	1 5/16	3.4	2/3V650SDS	SDS	D-2	5/16	1 5/16	4.5
6.90	6.85	1/3V690SH	SH	G-3	1/8	1 5/16	4.1	2/3V690SDS	SDS	D-2	5/16	1 5/16	4.7
8.00	7.95	1/3V800SDS	SDS	G-3	0	1 5/16	4.8	2/3V800SDS	SDS	D-3	5/16	1 5/16	4.8
10.60	10.55	1/3V1060SDS	SDS	G-3	0	1 5/16	7.4	2/3V1060SK	SK	F-3	5/32	1 15/16	9.6
14.00	13.95	1/3V1400SK	SK	G-3	7/16	1 15/16	12.1	2/3V1400SK	SK	F-3	5/32	1 15/16	12.6
19.00	18.95	1/3V1900SK	SK	G-3	7/16	1 15/16	18.0	2/3V1900SK	SK	F-3	5/32	1 15/16	20.6
25.00	24.95							2/3V2500SF	SF	E-3	1/4	2 1/16	31.5

Note: Cast iron sheaves may not exceed 6500 FPM.
This speed **DOES NOT** specify if dynamic balancing
(2 plane) is required. Contact customer service to
verify whether dynamic balancing is required.

* = Can only be mounted from one direction.

QD Bushing Sheaves

Cast Iron Sheaves - **Heavy Duty**
Bushed, **Three and Four Groove**
3V QD Sheaves

Order part number size
Example: 3/3V250JA

For 3V & 3VX Belts. See pages 113-114.
Order QD bushings separately.
Stock Bushings Located on Pages 84-85.

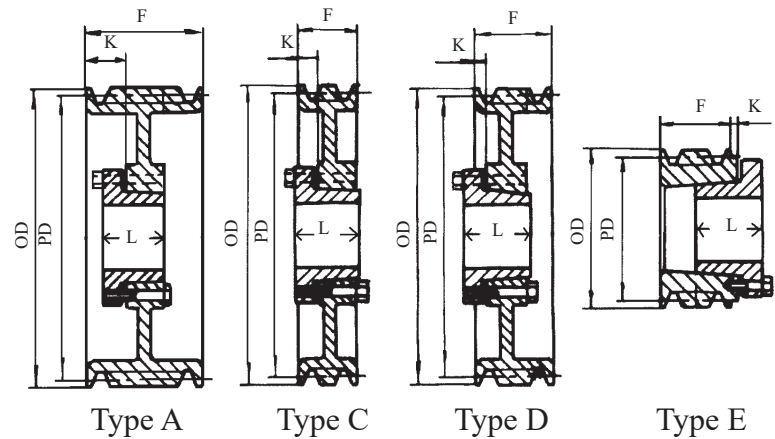
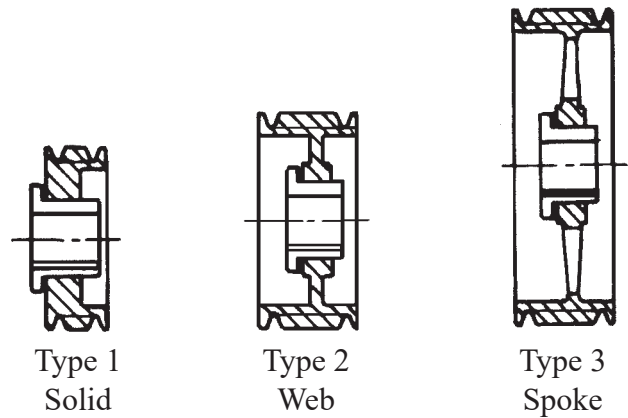

Diameters		3 Groove F = 1 1/2						4 Groove F = 1 29/32					
O.D.	P.D.	Part No.	Bush	Type	K	L	WT.	Part No.	Bush	Type	K	L	WT.
2.50	2.45	*3/3V250JA	JA	E-1	7/16	1	1.2						
2.65	2.60	*3/3V265JA	JA	D-1	1/8	1	1.1	*4/3V265JA	JA	D-1	0	1	1.4
2.80	2.75	*3/3V280JA	JA	D-1	1/8	1	1.3	*4/3V280JA	JA	D-1	0	1	1.7
3.00	2.95	*+3/3V300SH	SH	E-1	5/16	1 5/16	1.7	*+4/3V300SH	SH	E-1	0	1 5/16	2.0
3.15	3.10	*+3/3V315SH	SH	E-1	5/16	1 5/16	1.8	*+4/3V315SH	SH	E-1	0	1 5/16	2.0
3.35	3.30	*3/3V335SH	SH	D-1	1/8	1 5/16	1.6	*4/3V335SH	SH	D-1	1/8	1 5/16	1.9
3.65	3.60	*3/3V365SH	SH	D-1	1/8	1 5/16	2.0	*4/3V365SH	SH	D-1	1/8	1 5/16	2.3
4.12	4.07	3/3V412SH	SH	A-1	11/16	1 5/16	2.7	4/3V412SH	SH	A-1	13/16	1 5/16	3.1
4.50	4.45	3/3V450SDS	SDS	A-1	11/16	1 5/16	3.1	4/3V450SDS	SDS	A-1	13/16	1 5/16	3.5
4.75	4.70	3/3V475SDS	SDS	A-1	11/16	1 5/16	3.6	4/3V475SDS	SDS	A-1	13/16	1 5/16	3.7
5.00	4.95	3/3V500SDS	SDS	A-1	11/16	1 5/16	4.0	4/3V500SDS	SDS	A-1	13/16	1 5/16	4.3
5.30	5.25	3/3V530SDS	SDS	A-1	11/16	1 5/16	3.9	4/3V530SDS	SDS	A-1	13/16	1 5/16	5.0
5.60	5.55	3/3V560SDS	SDS	A-1	11/16	1 5/16	4.4	4/3V560SDS	SDS	A-1	13/16	1 5/16	5.5
6.00	5.95	3/3V600SDS	SDS	A-2	11/16	1 5/16	4.9	4/3V600SK	SK	D-1	5/8	1 15/16	7.0
6.50	6.45	3/3V650SDS	SDS	A-2	11/16	1 5/16	5.8	4/3V650SK	SK	D-2	5/8	1 15/16	7.3
6.90	6.85	3/3V690SDS	SDS	A-2	11/16	1 5/16	5.9	4/3V690SK	SK	D-2	5/8	1 15/16	8.2
8.00	7.95	3/3V800SK	SK	C-3	1/4	1 15/16	8.2	4/3V800SK	SK	D-3	5/8	1 15/16	9.4
10.60	10.55	3/3V1060SK	SK	C-3	1/4	1 15/16	12.0	4/3V1060SK	SK	D-3	5/8	1 15/16	13.4
14.00	13.95	3/3V1400SK	SK	C-3	1/4	1 15/16	14.8	4/3V1400SK	SK	D-3	5/8	1 15/16	18.3
19.00	18.95	3/3V1900SF	SF	C-3	1/4	2 1/16	26.0	4/3V1900SF	SF	C-3	21/32	2 1/16	29.7
25.00	24.95	3/3V2500SF	SF	C-3	1/4	2 1/16	42.0	4/3V2500SF	SF	C-3	21/32	2 1/16	44.0
33.50	33.45	3/3V3350SF	SF	C-3	1/4	2 1/16	70.8	4/3V3350E	E	C-3	9/32	2 3/4	78.0

* = Can only be mounted from one direction.

+ = Includes cap screws to be used in place of the ones that come with the bushing.

Note: Cast iron sheaves may not exceed 6500 FPM. This speed **DOES NOT** specify if dynamic balancing (2 plane) is required. Contact customer service to verify whether dynamic balancing is required.

Cast Iron Sheaves - Heavy Duty
Bushed, Five, Six, Seven and Eight Groove
Order part number size
Example: 5/3V475SDS

For 3V & 3VX Belts. See pages 113-114.
Order QD bushings separately.
Stock Bushings Located on Pages 84-85.

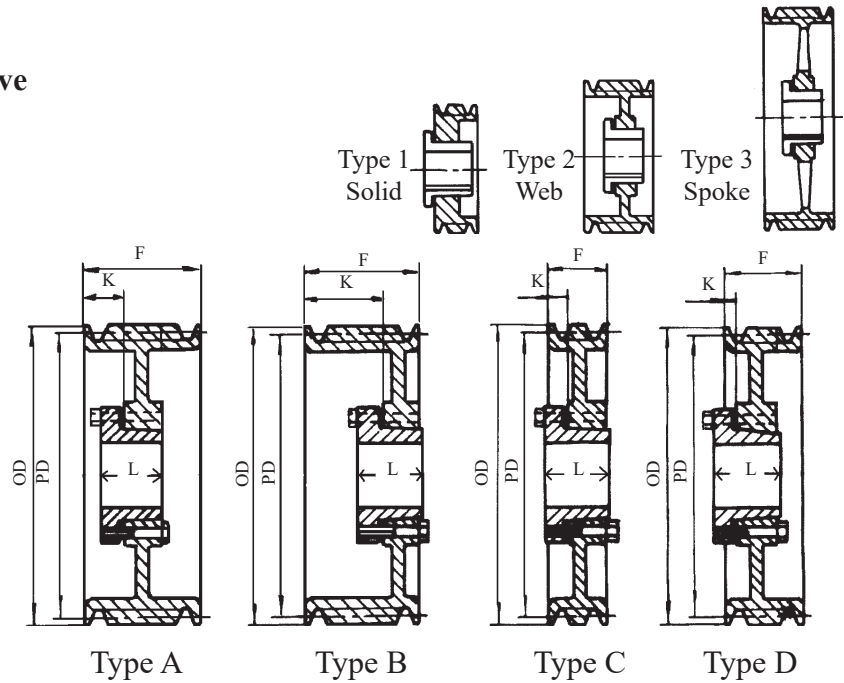

Diameters		5 Groove F = 2 5/16						6 Groove F = 2 23/32					
O.D.	P.D.	Part No.	Bush	Type	K	L	WT.	Part No.	Bush	Type	K	L	WT.
4.75	4.70	5/3V475SDS	SDS	A-1	13/16	1 15/16	4.3	*6/3V475SK	SK	D-1	0	1 15/16	5.0
5.00	4.95	5/3V500SDS	SDS	A-1	13/16	1 15/16	4.8	6/3V500SK	SK	D-1	0	1 15/16	5.7
5.30	5.25	5/3V530SK	SK	A-1	15/16	1 15/16	5.9	6/3V530SK	SK	A-1	1 5/16	1 15/16	6.7
5.60	5.55	5/3V560SK	SK	A-1	15/16	1 15/16	6.8	6/3V560SK	SK	A-1	1 5/16	1 15/16	7.5
6.00	5.95	5/3V600SK	SK	A-1	15/16	1 15/16	8.0	6/3V600SK	SK	A-1	1 5/16	1 15/16	8.8
6.50	6.45	5/3V650SK	SK	A-1	15/16	1 15/16	8.1	6/3V650SK	SK	A-1	1 5/16	1 15/16	9.3
6.90	6.85	5/3V690SK	SK	A-2	15/16	1 15/16	9.2	6/3V690SK	SK	A-2	1 5/16	1 15/16	10.0
8.00	7.95	5/3V800SK	SK	A-2	15/16	1 15/16	10.8	6/3V800SK	SK	A-2	1 5/16	1 15/16	11.7
10.60	10.55	5/3V1060SK	SK	A-2	15/16	1 15/16	15.3	6/3V1060SF	SF	A-2	7/8	2 1/16	19.1
14.00	13.95	5/3V1400SF	SF	A-3	7/8	2 1/16	23.4	6/3V1400SF	SF	A-3	7/8	2 1/16	24.2
19.00	18.95	5/3V1900SF	SF	A-3	7/8	2 1/16	37.6	6/3V1900E	E	B-3	1 3/32	2 3/4	39.5
25.00	24.95	5/3V2500E	E	C-3	11/16	2 3/4	53.0	6/3V2500E	E	B-3	1 3/32	2 3/4	65.7
33.50	33.45	5/3V3350E	E	C-3	11/16	2 3/4	87.0	6/3V3350E	E	B-3	1 3/32	2 3/4	80.0
Diameters		7 Groove F = 3 1/8						8 Groove F = 3 17/32					
O.D.	P.D.	Part No.	Bush	Type	K	L	WT.	Part No.	Bush	Type	K	L	WT.
4.75	4.70	*7/3V475SK	SK	D-1	1/8	1 15/16	3.8	*8/3V475SK	SK	D-1	1/8	1 15/16	5.8
5.00	4.95	*7/3V500SK	SK	D-1	1/8	1 15/16	4.8	*8/3V500SK	SK	D-1	1/8	1 15/16	6.8
5.30	5.25	7/3V530SK	SK	A-1	1 5/16	1 15/16	5.6	8/3V530SK	SK	A-1	1 5/16	1 15/16	7.6
5.60	5.55	7/3V560SK	SK	A-1	1 5/16	1 15/16	6.7	8/3V560SK	SK	A-1	1 5/16	1 15/16	8.7
6.00	5.95	7/3V600SK	SK	A-1	1 5/16	1 15/16	8.3	8/3V600SK	SK	A-1	1 5/16	1 15/16	10.3
6.50	6.45	7/3V650SK	SK	A-1	1 5/16	1 15/16	8.7	8/3V650SK	SK	A-1	1 5/16	1 15/16	10.7
6.90	6.85	7/3V690SK	SK	A-2	1 5/16	1 15/16	9.8	8/3V690SK	SK	A-2	1 5/16	1 15/16	11.8
8.00	7.95	7/3V800SF	SF	A-2	1 1/8	2 1/16	13.5	8/3V800SF	SF	A-2	1 1/8	2 1/16	15.5
10.60	10.55	7/3V1060SF	SF	A-2	1 1/8	2 1/16	18.9	8/3V1060SF	SF	A-2	1 1/8	2 1/16	21.9
14.00	13.95	7/3V1400E	E	A-3	1 1/4	2 3/4	31.4	8/3V1400E	E	A-3	1 1/4	2 3/4	33.4
19.00	18.95	7/3V1900E	E	A-3	1 1/4	2 3/4	45.2	8/3V1900E	E	A-3	1 1/4	2 3/4	47.2
25.00	24.95							8/3V2500E	E	A-3	1 1/4	2 3/4	67.8
33.50	33.45							8/3V3350F	F	B-3	1 1/32	3 3/4	112.0

Note: Cast iron sheaves may not exceed 6500 FPM. * = Can only be mounted from one direction.
This speed **DOES NOT** specify if dynamic balancing (2 plane) is required. Contact customer service to verify whether dynamic balancing is required.

QD Bushing Sheaves

Cast Iron Sheaves - **Heavy Duty**

Bushed, **Ten Groove**

Order part number size

Example: 10/3V475SK

For 3V & 3VX Belts. See pages 113-114.

Order QD bushings separately.

Stock Bushings Located on Pages 84-85.

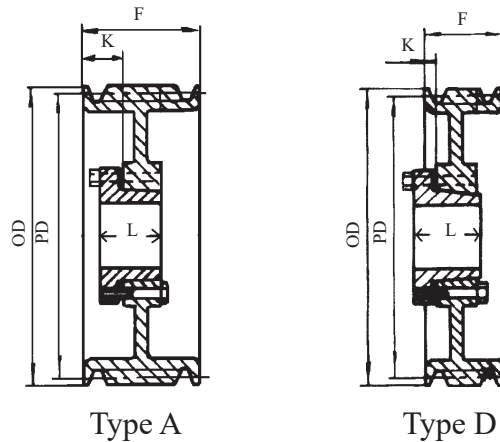
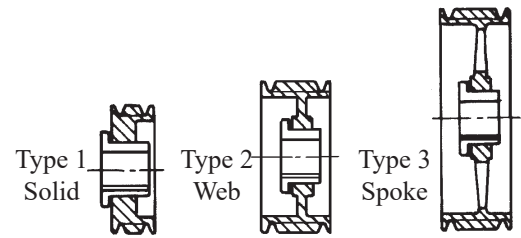

Diameters		10 Groove F = 4 11/32					
O.D.	P.D.	Part No.	Bush	Type	K	L	WT.
4.75	4.70	*10/3V475SK	SK	D-1	1/8	1 15/16	6.9
5.00	4.95	*10/3V500SK	SK	D-1	1/8	1 15/16	8.1
5.30	5.25	10/3V530SK	SK	A-1	1 7/16	1 15/16	8.8
5.60	5.55	10/3V560SK	SK	A-1	1 7/16	1 15/16	10.1
6.00	5.95	10/3V600SK	SK	A-1	1 7/16	1 15/16	13.8
6.50	6.45	10/3V650SK	SK	A-1	1 7/16	1 15/16	13.7
6.90	6.85	10/3V690SK	SK	A-2	1 7/16	1 15/16	14.1
8.00	7.95	10/3V800SF	SF	A-2	1 1/2	2 1/16	18.1
10.60	10.55	10/3V1060E	E	A-3	1 1/4	2 3/4	29.2
14.00	13.95	10/3V1400E	E	A-3	1 1/4	2 3/4	37.0
19.00	18.95	10/3V1900E	E	A-3	1 1/4	2 3/4	54.0
25.00	24.95	10/3V2500F	F	A-3	1 5/16	3 3/4	90.0
33.50	33.45	10/3V3350F	F	A-3	1 5/16	3 3/4	178.0

* = Can only be mounted from one direction.

Note: Cast iron sheaves may not exceed 6500 FPM. This speed **DOES NOT** specify if dynamic balancing (2 plane) is required. Contact customer service to verify whether dynamic balancing is required.

Cast Iron Sheaves - Heavy Duty
Bushed, Two and Three Groove
5V QD Sheaves
Order part number size
Example: 2/5V440SH

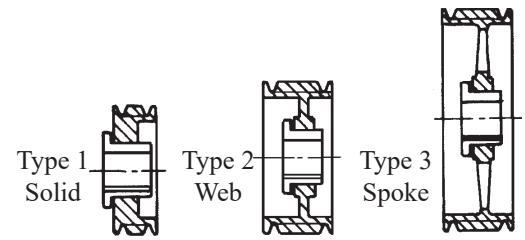

For 5V & 5VX Belts
See pages 113, 115 & 116.
Order QD bushings separately.
Stock Bushings Located on Pages 84-85.

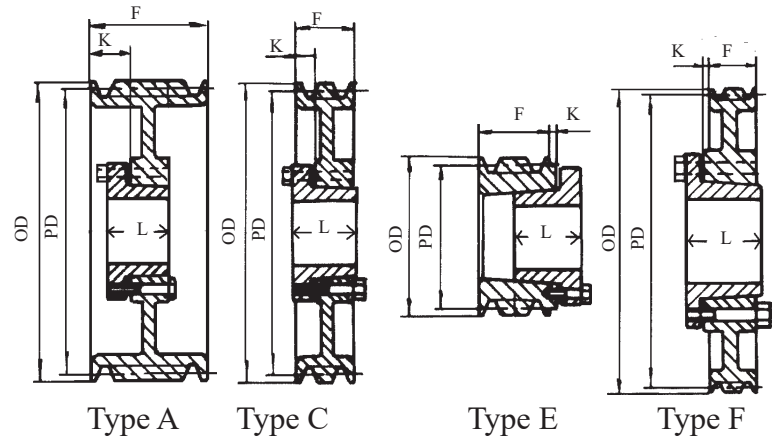

Diameters		2 Groove F = 1 11/16						3 Groove F = 2 3/8					
O.D.	P.D.	Part No.	Bush	Type	K	L	WT.	Part No.	Bush	Type	K	L	WT.
4.40	4.30	*2/5V440SH	SH	A-1	11/16	1 5/16	3.3	*3/5V440SDS	SDS	E-1	0	1 5/16	4.2
4.65	4.55	*2/5V465SDS	SDS	E-1	3/16	1 5/16	3.7	*3/5V465SDS	SDS	E-1	0	1 5/16	4.7
4.90	4.80	2/5V490SDS	SDS	A-1	11/16	1 5/16	3.9	3/5V490SDS	SDS	A-1	1 1/16	1 5/16	4.8
5.20	5.10	2/5V520SDS	SDS	A-1	11/16	1 5/16	4.6	3/5V520SDS	SDS	A-1	1 1/16	1 5/16	5.9
5.50	5.40	2/5V550SDS	SDS	A-1	11/16	1 5/16	5.1	3/5V550SDS	SDS	A-1	1 1/16	1 5/16	6.6
5.90	5.80	2/5V590SDS	SDS	A-1	11/16	1 5/16	5.6	3/5V590SDS	SDS	A-1	1 1/16	1 5/16	7.5
6.30	6.20	2/5V630SK	SK	C-1	7/16	1 15/16	7.4	3/5V630SK	SK	A-1	1 1/16	1 15/16	9.3
6.70	6.60	2/5V670SK	SK	C-1	7/16	1 15/16	7.5	3/5V670SK	SK	A-1	1 1/8	1 15/16	10.8
7.10	7.00	2/5V710SK	SK	C-1	7/16	1 15/16	7.9	3/5V710SF	SF	A-1	1 1/8	2 1/16	11.4
7.50	7.40	2/5V750SK	SK	C-1	7/16	1 15/16	8.7	3/5V750SF	SF	A-1	1 1/8	2 1/16	12.5
8.00	7.90	2/5V800SK	SK	C-2	7/16	1 15/16	10.0	3/5V800SF	SF	A-1	1 1/8	2 1/16	12.7
8.50	8.40	2/5V850SK	SK	C-2	7/16	1 15/16	10.8	3/5V850SF	SF	A-2	1 1/8	2 1/16	14.5
9.00	8.90	2/5V900SK	SK	C-2	7/16	1 15/16	11.4	3/5V900SF	SF	A-2	1 1/8	2 1/16	15.6
9.25	9.15	2/5V925SK	SK	C-2	7/16	1 15/16	12.0	3/5V925SF	SF	A-2	1 1/8	2 1/16	21.7
9.75	9.65	2/5V975SK	SK	C-2	7/16	1 15/16	12.6	3/5V975SF	SF	A-2	1 1/8	2 1/16	17.0
10.30	10.20	2/5V1030SK	SK	C-2	7/16	1 15/16	14.5	3/5V1030SF	SF	A-2	1 1/8	2 1/16	18.2
10.90	10.80	2/5V1090SK	SK	C-2	7/16	1 15/16	15.5	3/5V1090SF	SF	A-2	1 1/8	2 1/16	19.4
11.30	11.20	2/5V1130SK	SK	C-3	7/16	1 15/16	14.3	3/5V1130SF	SF	A-2	1 1/8	2 1/16	20.0
11.80	11.70	2/5V1180SK	SK	C-3	7/16	1 15/16	17.1	3/5V1180SF	SF	A-2	1 1/8	2 1/16	21.2
12.50	12.40	2/5V1250SF	SF	C-3	7/16	2 1/16	18.8	3/5V1250E	E	C-2	3/4	2 3/4	28.3
13.20	13.10	2/5V1320SF	SF	C-3	7/16	2 1/16	19.8	3/5V1320E	E	C-3	3/4	2 3/4	30.0
14.00	13.90	2/5V1400SF	SF	C-3	7/16	2 1/16	22.3	3/5V1400E	E	C-3	3/4	2 3/4	31.1
15.00	14.90	2/5V1500SF	SF	C-3	7/16	2 1/16	23.9	3/5V1500E	E	C-3	3/4	2 3/4	32.5
16.00	15.90	2/5V1600SF	SF	C-3	7/16	2 1/16	26.0	3/5V1600E	E	C-3	3/4	2 3/4	35.6
18.70	18.60	2/5V1870SF	SF	C-3	7/16	2 1/16	32.6	3/5V1870E	E	C-3	3/4	2 3/4	42.8
21.20	21.10	2/5V2120SF	SF	C-3	7/16	2 1/16	38.0	3/5V2120E	E	C-3	3/4	2 3/4	49.4
23.60	23.50	2/5V2360E	E	C-3	1/16	2 3/4	46.0	3/5V2360E	E	C-3	3/4	2 3/4	56.4
28.00	27.90	2/5V2800E	E	C-3	1/16	2 3/4	71.0	3/5V2800E	E	C-3	3/4	2 3/4	70.0
31.50	31.40							3/5V3150F	F	F-3	1/8	3 3/4	95.0
37.50	37.40							3/5V3750F	F	F-3	1/8	3 3/4	151.5
50.00	49.90							3/5V5000F	F	F-3	1/8	3 3/4	185.0

* = Can only be mounted from one direction.

Note: Cast iron sheaves may not exceed 6500 FPM.
This speed **DOES NOT** specify if dynamic balancing
(2 plane) is required. Contact customer service to
verify whether dynamic balancing is required.

QD Bushing Sheaves

Cast Iron Sheaves - Heavy Duty
Bushed, Four and Five Groove
5V QD Sheaves

Order part number size
Example: 4/5V440SD

For 5V & 5VX Belts
See pages 113, 115 & 116.
Order QD bushings separately.
Stock Bushings Located on Pages 84-85.

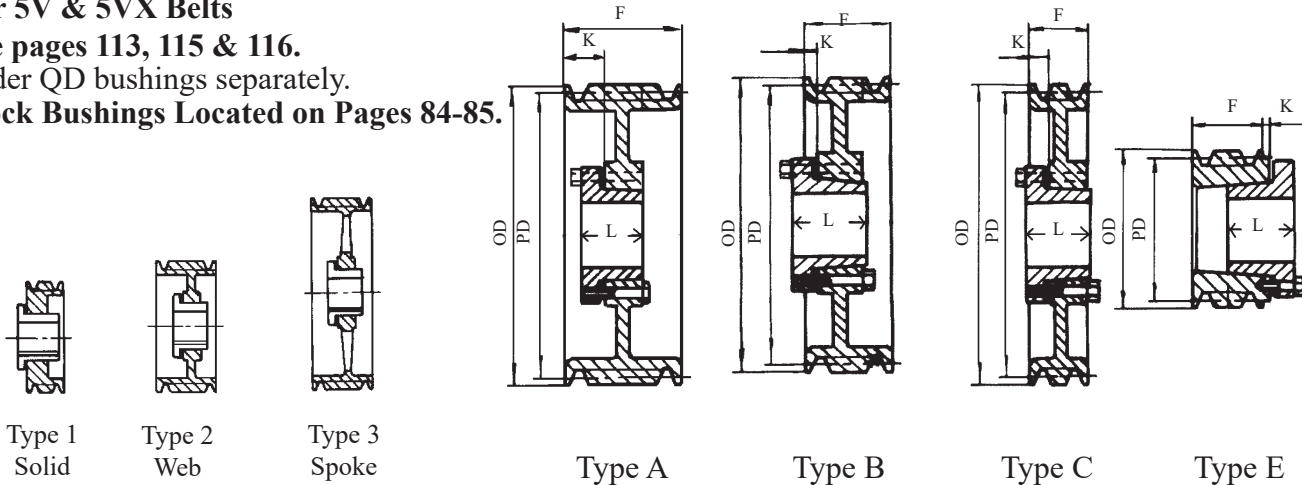

Diameters		4 Groove F = 3 1/16						5 Groove F = 3 3/4					
O.D.	P.D.	Part No.	Bush	Type	K	L	WT.	Part No.	Bush	Type	K	L	WT.
4.40	4.30	*4/5V440SD	SD	E-1	0	1 13/16	5.4	*5/5V440SD	SD	E-1	0	1 13/16	6.4
4.65	4.55	*4/5V465SD	SD	E-1	0	1 13/16	6.3	*5/5V465SD	SD	E-1	0	1 13/16	7.2
4.90	4.80	4/5V490SD	SD	A-1	1 5/16	1 13/16	6.8	5/5V490SD	SD	A-1	1 5/16	1 13/16	7.8
5.20	5.10	4/5V520SD	SD	A-1	1 5/16	1 13/16	7.7	5/5V520SD	SD	A-1	1 5/16	1 13/16	9.0
5.50	5.40	4/5V550SD	SD	A-1	1 5/16	1 13/16	8.9	5/5V550SD	SD	A-1	1 5/16	1 13/16	10.2
5.90	5.80	4/5V590SD	SD	A-1	1 5/16	1 13/16	10.2	5/5V590SK	SK	A-1	1 5/16	1 15/16	10.8
6.30	6.20	4/5V630SK	SK	A-1	1 5/16	1 15/16	10.8	5/5V630SK	SK	A-1	1 5/16	1 15/16	12.3
6.70	6.60	4/5V670SK	SK	A-1	1 5/16	1 15/16	12.4	5/5V670SF	SF	A-1	1 3/8	2 1/16	13.4
7.10	7.00	4/5V710SF	SF	A-1	1 1/16	2 1/16	13.4	5/5V710SF	SF	A-1	1 3/8	2 1/16	15.2
7.50	7.40	4/5V750SF	SF	A-1	1 1/16	2 1/16	15.1	5/5V750SF	SF	A-1	1 3/8	2 1/16	16.9
8.00	7.90	4/5V800E	E	B-1	1 7/16	2 3/4	18.0	5/5V800E	E	A-1	1 3/4	2 3/4	19.7
8.50	8.40	4/5V850E	E	B-1	1 7/16	2 3/4	20.1	5/5V850E	E	A-1	1 3/4	2 3/4	23.1
9.00	8.90	4/5V900E	E	B-1	1 7/16	2 3/4	22.3	5/5V900E	E	A-1	1 3/4	2 3/4	26.4
9.25	9.15	4/5V925E	E	B-1	1 7/16	2 3/4	23.9	5/5V925E	E	A-1	1 3/4	2 3/4	28.3
9.75	9.65	4/5V975E	E	B-2	1 7/16	2 3/4	23.3	5/5V975E	E	A-2	1 3/4	2 3/4	26.2
10.30	10.20	4/5V1030E	E	B-2	1 7/16	2 3/4	25.5	5/5V1030E	E	A-2	1 3/4	2 3/4	28.5
10.90	10.80	4/5V1090E	E	B-2	1 7/16	2 3/4	28.0	5/5V1090E	E	A-2	1 3/4	2 3/4	30.7
11.30	11.20	4/5V1130E	E	B-2	1 7/16	2 3/4	28.5	5/5V1130E	E	A-2	1 3/4	2 3/4	32.3
11.80	11.70	4/5V1180E	E	B-2	1 7/16	2 3/4	29.9	5/5V1180E	E	A-2	1 3/4	2 3/4	33.5
12.50	12.40	4/5V1250E	E	B-2	1 7/16	2 3/4	31.2	5/5V1250E	E	A-2	1 3/4	2 3/4	36.3
13.20	13.10	4/5V1320E	E	B-2	1 7/16	2 3/4	33.7	5/5V1320E	E	A-2	1 3/4	2 3/4	38.4
14.00	13.90	4/5V1400E	E	B-3	1 7/16	2 3/4	34.4	5/5V1400E	E	A-3	1 3/4	2 3/4	40.0
15.00	14.90	4/5V1500E	E	B-3	1 7/16	2 3/4	37.0	5/5V1500E	E	A-3	1 3/4	2 3/4	42.7
16.00	15.90	4/5V1600E	E	B-3	1 7/16	2 3/4	39.6	5/5V1600E	E	A-3	1 3/4	2 3/4	58.0
18.70	18.60	4/5V1870E	E	A-3	1 1/4	2 3/4	51.8	5/5V1870F	F	B-3	1 1/4	3 3/4	67.0
21.20	21.10	4/5V2120E	E	A-3	1 1/4	2 3/4	58.3	5/5V2120F	F	B-3	1 1/4	3 3/4	88.0
23.60	23.50	4/5V2360F	F	C-3	7/8	3 3/4	70.0	5/5V2360F	F	B-3	1 1/4	3 3/4	114.9
28.00	27.90	4/5V2800F	F	C-3	7/8	3 3/4	92.0	5/5V2800F	F	B-3	1 1/4	3 3/4	126.0
31.50	31.40	4/5V3150F	F	C-3	7/8	3 3/4	108.0	5/5V3150J	J	C-3	9/16	4 5/8	132.0
37.50	37.40	4/5V3750F	F	C-3	7/8	3 3/4	138.0	5/5V3750J	J	C-3	9/16	4 5/8	174.0
50.00	49.90	4/5V5000J	J	B-3	1/8	4 5/8	227.0	5/5V5000J	J	C-3	9/16	4 5/8	247.0

* = Can only be mounted from one direction.
Note: Cast iron sheaves may not exceed 6500 FPM.
 This speed **DOES NOT** specify if dynamic balancing
 (2 plane) is required. Contact customer service to verify
 whether dynamic balancing is required.

Cast Iron Sheaves - Heavy Duty
Bushed, Six and Seven Groove
5V QD Sheaves
Order part number size
Example: 6/5V440SD



For 5V & 5VX Belts

See pages 113, 115 & 116.

Order QD bushings separately.

Stock Bushings Located on Pages 84-85.

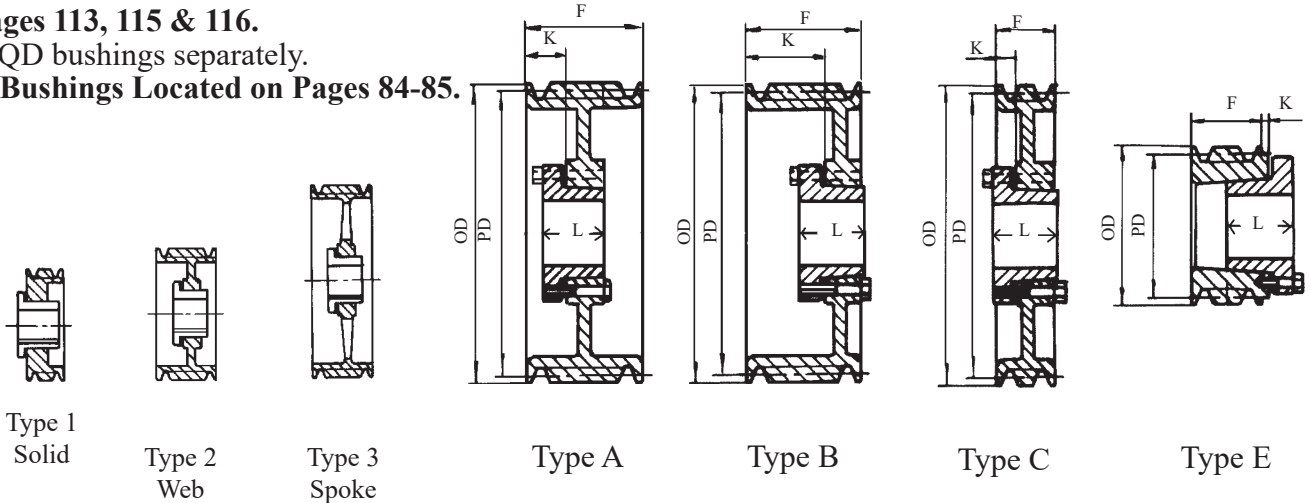

Type 1
Solid

Type 2
Web

Type 3
Spoke

Type A

Type B

Type C

Type E

Diameters		6 Groove F = 4 7/16						7 Groove F = 5 1/8					
O.D.	P.D.	Part No.	Bush	Type	K	L	WT.	Part No.	Bush	Type	K	L	WT.
4.40	4.30	*6/5V440SD	SD	E-1	0	1 13/16	7.7						
4.65	4.55	*6/5V465SD	SD	E-1	0	1 13/16	8.1						
4.90	4.80	6/5V490SD	SD	A-1	1 5/16	1 13/16	8.1						
5.20	5.10	6/5V520SD	SD	A-1	1 5/16	1 13/16	10.5						
5.50	5.40	6/5V550SD	SD	A-1	1 5/16	1 13/16	12.0						
5.90	5.80	6/5V590SK	SK	A-1	1 5/16	1 15/16	12.6						
6.30	6.20	6/5V630SK	SK	A-1	1 5/16	1 15/16	14.5						
6.70	6.60	6/5V670SF	SF	A-1	1 5/8	2 1/16	15.4						
7.10	7.00	6/5V710SF	SF	A-1	1 5/8	2 1/16	17.4	7/5V710SF	SF	A-1	2 1/8	2 1/16	17.7
7.50	7.40	6/5V750SF	SF	A-1	1 5/8	2 1/16	19.4	7/5V750SF	SF	A-1	2 1/8	2 1/16	20.1
8.00	7.90	6/5V800E	E	A-1	2	2 3/4	22.7	7/5V800E	E	A-1	2 1/2	2 3/4	23.8
8.50	8.40	6/5V850E	E	A-1	2	2 3/4	26.0	7/5V850E	E	A-1	2 1/2	2 3/4	26.5
9.00	8.90	6/5V900E	E	A-1	2	2 3/4	29.4	7/5V900E	E	A-1	2 1/2	2 3/4	32.0
9.25	9.15	6/5V925E	E	A-1	2	2 3/4	30.8	7/5V925E	F	A-1	2 9/16	3 3/4	37.5
9.75	9.65	6/5V975E	E	A-2	2	2 3/4	35.0	7/5V975E	F	A-1	2 9/16	3 3/4	43.0
10.30	10.20	6/5V1030E	E	A-2	2	2 3/4	33.0	7/5V1030F	F	A-1	2 9/16	3 3/4	44.3
10.90	10.80	6/5V1090E	E	A-2	2	2 3/4	35.6	7/5V1090F	F	A-2	2 9/16	3 3/4	45.5
11.30	11.20	6/5V1130E	E	A-2	2	2 3/4	36.7	7/5V1130F	F	A-2	2 9/16	3 3/4	47.0
11.80	11.70	6/5V1180E	E	A-2	2	2 3/4	41.4	7/5V1180F	F	A-2	2 9/16	3 3/4	50.0
12.50	12.40	6/5V1250F	F	B-2	15/16	3 3/4	45.2	7/5V1250F	F	A-2	2 9/16	3 3/4	53.3
13.20	13.10	6/5V1320F	F	B-2	15/16	3 3/4	50.0	7/5V1320F	F	A-2	2 9/16	3 3/4	56.0
14.00	13.90	6/5V1400F	F	B-2	15/16	3 3/4	52.6	7/5V1400F	F	A-2	2 9/16	3 3/4	60.5
15.00	14.90	6/5V1500F	F	B-3	15/16	3 3/4	55.2	7/5V1500F	F	A-2	2 9/16	3 3/4	65.0
16.00	15.90	6/5V1600F	F	B-3	1 15/16	3 3/4	58.0	7/5V1600F	F	A-2	2 9/16	3 3/4	71.0
18.70	18.60	6/5V1870F	F	A-3	1 5/16	3 3/4	70.0	7/5V1870J	J	A-3	1 9/16	4 5/8	91.0
21.20	21.10	6/5V2120F	F	A-3	1 5/16	3 3/4	81.0						
23.60	23.50	6/5V2360J	J	B-3	1 1/4	4 5/8	117.5						
28.00	27.90	6/5V2800J	J	B-3	1 1/4	4 5/8	125.0						
31.50	31.40	6/5V3150J	J	B-3	1 1/4	4 5/8	200.0						
37.50	37.40	6/5V3750J	J	B-3	1 1/4	4 5/8	235.0						
50.00	49.90	6/5V5000M	M	C-3	3/4	6 3/4	330.0						

* = Can only be mounted from one direction.

Note: Cast iron sheaves may not exceed 6500 FPM.

This speed **DOES NOT** specify if dynamic balancing (2 plane) is required. Contact customer service to verify whether dynamic balancing is required.

QD Bushing Sheaves

Cast Iron Sheaves - **Heavy Duty**
Bushed, **Eight and Ten Groove**
Order part number size
Example: 8/5V710SF



For 5V & 5VX Belts

See pages 113, 115 & 116.

Order QD bushings separately.

Stock Bushings Located on Pages 84-85.

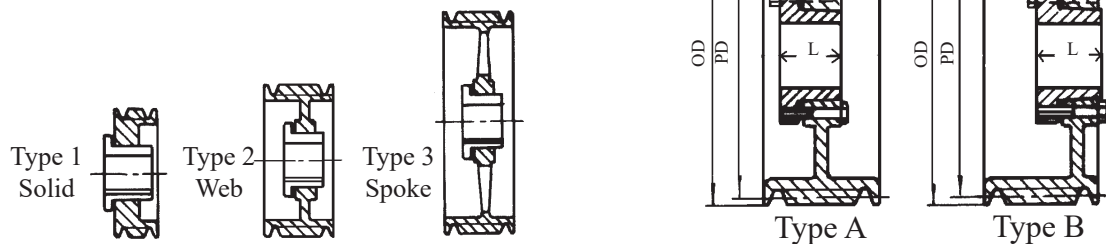

Diameters		8 Groove F = 5 13/16						10 Groove F = 7 3/16					
O.D.	P.D.	Part No.	Bush	Type	K	L	WT.	Part No.	Bush	Type	K	L	WT.
7.10	7.00	8/5V710SF	SF	A-1	2 1/8	2 1/16	20.7						
7.50	7.40	8/5V750SF	SF	A-1	2 1/8	2 1/16	23.1						
8.00	7.90	8/5V800E	E	A-1	2 1/2	2 3/4	26.8	10/5V800E	E	A-1	3 1/4	2 3/4	30.9
8.50	8.40	8/5V850E	E	A-1	2 1/2	2 3/4	29.5	10/5V850E	E	A-1	3 1/4	2 3/4	34.9
9.00	8.90	8/5V900E	E	A-1	2 1/2	2 3/4	35.0	10/5V900F	F	A-1	3 5/16	3 3/4	43.7
9.25	9.15	8/5V925F	F	A-1	2 9/16	3 3/4	40.5	10/5V925F	F	A-1	3 5/16	3 3/4	45.6
9.75	9.65	8/5V975F	F	A-1	2 9/16	3 3/4	46.0	10/5V975F	F	A-1	3 5/16	3 3/4	51.0
10.30	10.20	8/5V1030F	F	A-1	2 9/16	3 3/4	47.3	10/5V1030F	F	A-1	3 5/16	3 3/4	59.0
10.90	10.80	8/5V1090F	F	A-2	2 9/16	3 3/4	48.5	10/5V1090F	F	A-2	3 5/16	3 3/4	65.5
11.30	11.20	8/5V1130F	F	A-2	2 9/16	3 3/4	50.0	10/5V1130F	F	A-2	3 5/16	3 3/4	60.8
11.80	11.70	8/5V1180F	F	A-2	2 9/16	3 3/4	53.0	10/5V1180F	F	A-2	3 5/16	3 3/4	63.0
12.50	12.40	8/5V1250F	F	A-2	2 9/16	3 3/4	56.3	10/5V1250J	J	A-2	3 9/16	4 5/8	71.3
13.20	13.10	8/5V1320F	F	A-2	2 9/16	3 3/4	59.0	10/5V1320J	J	A-2	3 9/16	4 5/8	79.5
14.00	13.90	8/5V1400F	F	A-2	2 9/16	3 3/4	63.5	10/5V1400J	J	A-2	3 9/16	4 5/8	88.0
15.00	14.90	8/5V1500F	F	A-2	2 9/16	3 3/4	68.0	10/5V1500J	J	A-2	3 9/16	4 5/8	94.5
16.00	15.90	8/5V1600F	F	A-2	2 9/16	3 3/4	74.0	10/5V1600J	J	A-2	3 9/16	4 5/8	101.2
18.70	18.60	8/5V1870J	J	A-3	1 9/16	4 5/8	94.0	10/5V1870J	J	A-3	1 9/16	4 5/8	109.6
21.20	21.10	8/5V2120J	J	A-3	1 9/16	4 5/8	106.0	10/5V2120J	J	A-3	1 9/16	4 5/8	122.0
23.60	23.50	8/5V2360J	J	A-3	1 9/16	4 5/8	120.0	10/5V2360M	M	B-3	1 15/16	6 3/4	174.0
28.00	27.90	8/5V2800J	J	A-3	1 9/16	4 5/8	145.0	10/5V2800M	M	B-3	1 15/16	6 3/4	214.0
31.50	31.40	8/5V3150M	M	B-3	5/8	6 3/4	196.2	10/5V3150M	M	B-3	1 15/16	6 3/4	238.0
37.50	37.40	8/5V3750M	M	B-3	5/8	6 3/4	248.0	10/5V3750M	M	B-3	1 15/16	6 3/4	283.0
50.00	49.90	8/5V5000M	M	B-3	5/8	6 3/4	367.0	10/5V5000M	M	B-3	1 15/16	6 3/4	427.0

Note: Cast iron sheaves may not exceed 6500 FPM.
This speed **DOES NOT** specify if dynamic balancing
(2 plane) is required. Contact customer service to verify
whether dynamic balancing is required.

Cast Iron Sheaves - Heavy Duty
Bushed, **Four, Five, Six and Seven Groove**
8V QD Sheaves
Order part number size
Example: 4/8V1250F

For 8V Belts. See pages 113, 117 & 118.
Order QD bushings separately.
Stock Bushings Located on Pages 84-85.

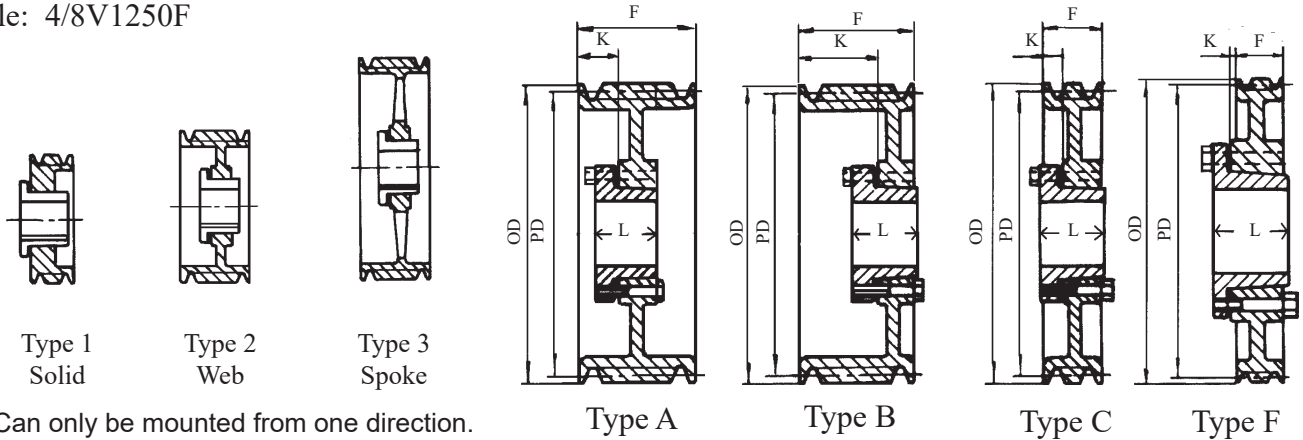

* = Can only be mounted from one direction.

Diameters		4 Groove F = 4 7/8						5 Groove F = 6					
O.D.	P.D.	Part No.	Bush	Type	K	L	WT.	Part No.	Bush	Type	K	L	WT.
12.50	12.30	4/8V1250F	F	A-2	1 3/16	3 3/4	60.0	5/8V1250F	F	A-2	2 5/16	3 3/4	82.8
13.20	13.00	4/8V1320F	F	A-2	1 3/16	3 3/4	64.0	5/8V1320F	F	A-2	2 5/16	3 3/4	96.0
14.00	13.80	4/8V1400F	F	A-2	1 3/16	3 3/4	68.3	5/8V1400F	F	A-2	2 5/16	3 3/4	81.0
15.00	14.80	4/8V1500F	F	A-2	1 3/16	3 3/4	72.6	5/8V1500F	F	A-2	2 5/16	3 3/4	84.5
16.00	15.80	4/8V1600F	F	A-2	1 3/16	3 3/4	77.0	5/8V1600F	F	A-2	2 5/16	3 3/4	95.5
17.00	16.80	4/8V1700F	F	A-3	1 3/16	3 3/4	83.5	5/8V1700J	J	A-2	2	4 5/8	104.5
18.00	17.80	4/8V1800F	F	A-3	1 3/16	3 3/4	90.0	5/8V1800J	J	A-2	2	4 5/8	115.2
19.00	18.80	4/8V1900F	F	A-3	1 3/16	3 3/4	112.0	5/8V1900J	J	A-3	2	4 5/8	122.0
20.00	19.80	4/8V2000J	J	A-3	1 7/16	4 5/8	114.0	5/8V2000J	J	A-3	2	4 5/8	133.0
21.20	21.00	4/8V2120J	J	A-3	1 7/16	4 5/8	140.0	5/8V2120J	J	A-3	2	4 5/8	140.0
22.40	22.20	4/8V2240J	J	A-3	1 7/16	4 5/8	150.0	5/8V2240M	M	B-3	13/16	6 3/4	182.0
24.80	24.60	4/8V2480M	M	F-3	5/16	6 3/4	211.0	5/8V2480M	M	B-3	13/16	6 3/4	201.0
30.00	29.80	4/8V3000M	M	F-3	5/16	6 3/4	264.0	5/8V3000M	M	B-3	13/16	6 3/4	254.0
35.50	35.30	4/8V3550M	M	F-3	5/16	6 3/4	367.0	5/8V3550M	M	B-3	13/16	6 3/4	298.0
40.00	39.80	4/8V4000M	M	F-3	5/16	6 3/4	300.0	5/8V4000M	M	B-3	13/16	6 3/4	337.0
44.50	44.30	4/8V4450M	M	C-3	13/16	6 3/4	350.0	5/8V4450N	N	C-3	15/16	8 1/8	375.0
53.00	52.80	4/8V5300M	M	C-3	13/16	6 3/4	400.0	5/8V5300N	N	F-3	1/4	8 1/8	625.0
Diameters		6 Groove F = 7 1/8						7 Groove F = 8 1/4					
O.D.	P.D.	Part No.	Bush	Type	K	L	WT.	Part No.	Bush	Type	K	L	WT.
12.50	12.30	6/8V1250F	F	A-2	2 5/16	3 3/4	81.0	7/8V1250J	J	A-1	3 9/16	4 5/8	113.0
13.20	13.00	6/8V1320F	F	A-2	2 5/16	3 3/4	85.4	7/8V1320J	J	A-1	3 9/16	4 5/8	127.0
14.00	13.80	6/8V1400F	F	A-2	2 5/16	3 3/4	96.0	7/8V1400J	J	A-2	3 9/16	4 5/8	123.0
15.00	14.80	6/8V1500J	J	A-2	2 9/16	4 5/8	110.0	7/8V1500J	J	A-2	3 15/16	4 5/8	142.0
16.00	15.80	6/8V1600J	J	A-2	2 9/16	4 5/8	118.0	7/8V1600J	J	A-2	3 15/16	4 5/8	160.0
17.00	16.80	6/8V1700J	J	A-2	2 9/16	4 5/8	126.0	7/8V1700M	M	A-2	3 15/16	6 3/4	226.0
18.00	17.80	6/8V1800J	J	A-2	2 9/16	4 5/8	133.0	7/8V1800M	M	A-2	3 15/16	6 3/4	228.0
19.00	18.80	6/8V1900J	J	A-3	2 9/16	4 5/8	157.0	7/8V1900M	M	A-2	3 15/16	6 3/4	220.0
20.00	19.80	6/8V2000M	M	B-3	15/16	6 3/4	185.0	7/8V2000M	M	A-3	3 15/16	6 3/4	210.0
21.20	21.00	6/8V2120M	M	B-3	1 15/16	6 3/4	194.0						
22.40	22.20	6/8V2240M	M	B-3	1 15/16	6 3/4	221.0						
24.80	24.60	6/8V2480M	M	B-3	1 15/16	6 3/4	248.0						
30.00	29.80	6/8V3000M	M	B-3	1 15/16	6 3/4	276.0						
35.50	35.30	6/8V3550N	N	C-3	1 1/8	8 1/8	444.0						
40.00	39.80	6/8V4000N	N	C-3	1 1/8	8 1/8	519.0						
44.50	44.30	6/8V4450N	N	C-3	7/8	8 1/8	600.0						
53.00	52.80	6/8V5300N	N	C-3	7/8	8 1/8	768.0						
63.00	62.80	*6/8V6300P	P	C-3	2	9 3/8	890.0						
71.00	70.80	*6/8V7100P	P	C-3	2	9 3/8	1000.0						

Note: Cast iron sheaves may not exceed 6500 FPM. This speed **DOES NOT** specify if dynamic balancing (2 plane) is required. Contact customer service to verify whether dynamic balancing is required.

QD Bushing Sheaves

Cast Iron Sheaves - **Heavy Duty**
Bushed, **Eight and Ten Groove**

Order part number size

Example: 8/8V1250J

For 8V Belts.

See pages 113, 117 & 118.

Order QD bushings separately.

Stock Bushings Located on Pages 84-85.

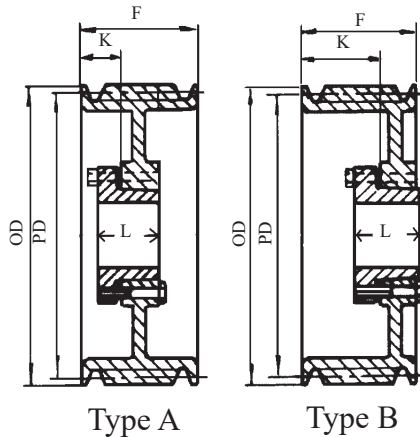
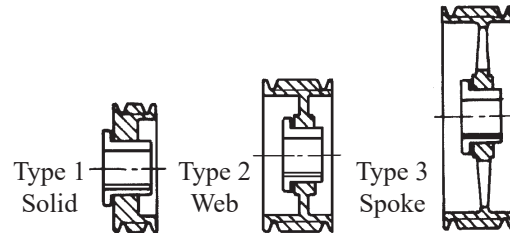

Diameters		8 Groove F = 9 3/8						10 Groove F = 11 5/8					
O.D.	P.D.	Part No.	Bush	Type	K	L	WT.	Part No.	Bush	Type	K	L	WT.
12.50	12.30	8/8V1250J	J	A-1	3 9/16	4 5/8	117.0	10/8V1250J	J	A-1	3 9/16	4 5/8	134.0
13.20	13.00	8/8V1320J	J	A-2	3 9/16	4 5/8	131.0	10/8V1320J	J	A-1	3 9/16	4 5/8	150.5
14.00	13.80	8/8V1400J	J	A-2	3 9/16	4 5/8	127.0	10/8V1400J	J	A-1	3 9/16	4 5/8	167.0
15.00	14.80	8/8V1500J	J	A-2	3 15/16	4 5/8	146.0	10/8V1500M	M	A-1	3 15/16	6 3/4	225.0
16.00	15.80	8/8V1600J	J	A-2	3 15/16	4 5/8	162.0	10/8V1600M	M	A-1	3 15/16	6 3/4	263.0
17.00	16.80	8/8V1700M	M	A-2	3 15/16	6 3/4	228.0	10/8V1700M	M	A-2	3 15/16	6 3/4	267.5
18.00	17.80	8/8V1800M	M	A-2	3 15/16	6 3/4	230.0	10/8V1800M	M	A-2	3 15/16	6 3/4	272.0
19.00	18.80	8/8V1900M	M	A-2	3 15/16	6 3/4	222.0	10/8V1900M	M	A-2	3 15/16	6 3/4	269.0
20.00	19.80	8/8V2000M	M	A-2	3 15/16	6 3/4	213.0	10/8V2000M	M	A-3	3 15/16	6 3/4	253.0
21.20	21.00	8/8V2120M	M	A-3	3 15/16	6 3/4	230.0	10/8V2120M	M	A-3	3 15/16	6 3/4	267.0
22.40	22.20	8/8V2240M	M	A-3	3 15/16	6 3/4	244.0	10/8V2240N	N	A-2	2 1/4	8 1/8	332.0
24.80	24.60	8/8V2480N	N	A-3	2 1/4	8 1/8	365.7	10/8V2480N	N	A-3	2 1/4	8 1/8	356.0
30.00	29.80	8/8V3000N	N	A-3	2 1/4	8 1/8	410.0	10/8V3000N	N	A-3	2 1/4	8 1/8	425.0
35.50	35.30	8/8V3550N	N	A-3	2 1/4	8 1/8	508.0	*10/8V3550P	P	A-3	2 5/8	9 3/8	635.0
40.00	39.80	8/8V4000N	N	A-3	2 1/4	8 1/8	592.0	*10/8V4000P	P	A-3	2 5/8	9 3/8	754.0
44.50	44.30	*8/8V4450P	P	B-3	2 5/8	9 3/8	860.0	*10/8V4450P	P	A-3	2 5/8	9 3/8	813.5
53.00	52.80	*8/8V5300P	P	B-3	2 5/8	9 3/8	992.0	*10/8V5300P	P	A-3	1 3/4	9 3/8	1137.0
63.00	62.80	*8/8V6300P	P	B-3	2 5/8	9 3/8	1050.0	*10/8V6300W	W	A-3	2 5/8	11 3/8	1500.0
71.00	70.80	*8/8V7100W	W	B-3	2 1/4	11 3/8	1808.0	*10/8V7100W	W	A-3	2 5/8	11 3/8	1916.0

* = Can only be mounted from one direction.

Note: Cast iron sheaves may not exceed 6500 FPM.

This speed **DOES NOT** specify if dynamic balancing (2 plane) is required. Contact customer service to verify whether dynamic balancing is required.

9 Groove & Severe Duty Ductile Iron Sheaves (Max Rim Speed = 8,000FPM) are available upon request.

Cast Iron Sheaves - **Heavy Duty**
Bushed, **Twelve Groove**
Order part number size
Example: 12/8V1250M
For 8V Belts.
See pages 113, 117 & 118.
Order QD bushings separately.
Stock Bushings Located on Pages 84-85.

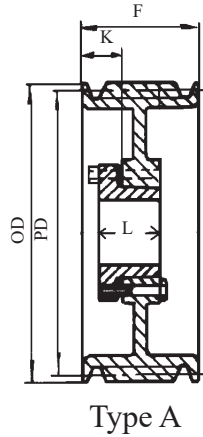
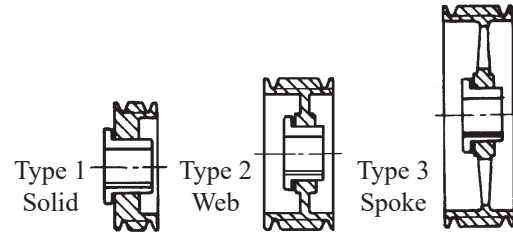

Diameters		12 Groove F = 13 7/8					
O.D.	P.D.	Part No.	Bush	Type	K	L	WT.
12.50	12.30	12/8V1250M	M	A-1	3 15/16	6 3/4	198.4
13.20	13.00	12/8V1320M	M	A-1	3 15/16	6 3/4	220.5
14.00	13.80	12/8V1400M	M	A-1	3 15/16	6 3/4	242.5
15.00	14.80	12/8V1500M	M	A-1	3 15/16	6 3/4	275.6
16.00	15.80	12/8V1600M	M	A-1	3 15/16	6 3/4	313.1
17.00	16.80	12/8V1700M	M	A-1	3 15/16	6 3/4	348.3
18.00	17.80	12/8V1800M	M	A-2	3 15/16	6 3/4	352.7
19.00	18.80	12/8V1900N	N	A-2	2 1/16	8 1/8	396.8
20.00	19.80	12/8V2000N	N	A-2	2 1/16	8 1/8	421.1
21.20	21.00	12/8V2120N	N	A-2	2 1/16	8 1/8	452.0
22.40	22.20	12/8V2240N	N	A-2	2 1/16	8 1/8	485.0
24.80	24.60	12/8V2480N	N	A-2	2 1/16	8 1/8	515.9
30.00	29.80	*12/8V3000P	P	A-3	2 3/8	9 3/8	646.0
35.50	35.30	*12/8V3550P	P	A-3	2 3/8	9 3/8	754.0
35.50	35.30	*12/8V3550W	W	A-3	2 3/8	11 3/8	869.1
40.00	39.80	*12/8V4000P	P	A-3	2 3/8	9 3/8	870.9
44.50	44.30	*12/8V4450P	P	A-3	2 3/8	9 3/8	992.1
53.00	52.80	*12/8V5300W	W	A-3	2 5/8	11 3/8	1410.0
63.00	62.80	*12/8V6300W	W	A-3	2 7/8	11 3/8	1700.0
71.00	70.80	*12/8V7100W	W	A-3	2 7/8	11 3/8	2000.0

* = Can only be mounted from one direction.
Note: Cast iron sheaves may not exceed 6500 FPM.
This speed **DOES NOT** specify if dynamic balancing (2 plane) is required. Contact customer service to verify whether dynamic balancing is required.

Severe Duty Ductile Iron Sheaves
(Max Rim Speed = 8,000FPM) are available upon request.

MasterDrive, Inc. offers the following stock sheaves specifically for the oilfield industry. More sizes available upon request.

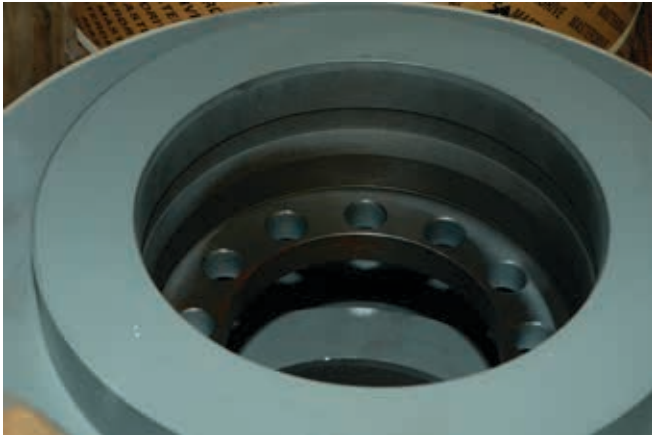

Part No.	Description
10/8V2120-752	GE752 Motor Mount Sheave, 10 Groove, 8V Section, 21.2" O.D.
12/8V2120-752	GE752 Motor Mount Sheave, 12 Groove, 8V Section, 21.2" O.D.
10/8V2240-752	GE752 Motor Mount Sheave, 10 Groove, 8V Section, 22.4" O.D.
12/8V2240-752	GE752 Motor Mount Sheave, 12 Groove, 8V Section, 22.4" O.D.
10/8V2480-752	GE752 Motor Mount Sheave, 10 Groove, 8V Section, 24.8" O.D.
12/8V2480-752	GE752 Motor Mount Sheave, 12 Groove, 8V Section, 24.8" O.D.
12/8V2480-GEB28	GEB28 Motor Mount Sheave, 12 Groove, 8V Section, 24.8" O.D.
10/8V2120-GEB29	GEB29 Motor Mount Sheave, 10 Groove, 8V Section, 21.2" O.D.
12/8V2120-GEB29	GEB29 Motor Mount Sheave, 12 Groove, 8V Section, 21.2" O.D.
12/8V2240-GEB29	GEB29 Motor Mount Sheave, 12 Groove, 8V Section, 22.4" O.D.
12/8V2480-GEB29	GEB29 Motor Mount Sheave, 12 Groove, 8V Section, 24.8" O.D.
12/8V2480N DI	Ductile Iron QD Sheave, 12 Groove, 8V Section, 24.8" O.D.
12/8V3550W DI	Ductile Iron Oversize Hub QD Sheave, 12 Groove, 8V Section, 35.5" O.D.
12/8V3550W	Oversize Hub QD Sheave, 12 Groove, 8V Section, 35.5" O.D.
12/8V3550W OFFSET	Oversize 1" Offset Hub QD Sheave, 12 Groove, 8V Section, 35.5" O.D.
12/8V4000W OFFSET	Oversize 1" Offset Hub QD Sheave, 12 Groove, 8V Section, 40.0" O.D.
12/8V4450W OFFSET	Oversize 1" Offset Hub QD Sheave, 12 Groove, 8V Section, 44.5" O.D.
12/8V4000W FLUSH	Oversize Flush Hub QD Sheave, 12 Groove, 8V Section, 40.0" O.D.
12/8V4000S FLUSH	Oversize Flush Hub QD Sheave, 12 Groove, 8V Section, 40.0" O.D.
8/8V3550W DI OFFSET	Ductile Iron 3" Offset Hub QD Sheave, 8 Groove, 8V Section, 35.5" O.D.
12/8V4000W DI OFFSET	Ductile Iron 1" Offset Hub QD Sheave, 12 Groove, 8V Section, 40.0" O.D.
12/8V4450W DI OFFSET	Ductile Iron 1" Offset Hub QD Sheave, 12 Groove, 8V Section, 44.5" O.D.
12/8V4450S DI OFFSET	Ductile Iron 1" Offset Hub QD Sheave, 12 Groove, 8V Section, 44.5" O.D.
12/8V6300W DI OFFSET	Ductile Iron 1" Offset Hub QD Sheave, 12 Groove, 8V Section, 63.0" O.D.
4C60-3-3/8	Bored-To-Size Sheave, 4 Groove, C Section, 6" P.D.
5C60-3-3/8	Bored-To-Size Sheave, 5 Groove, C Section, 6" P.D.
5C70-3-3/8	Bored-To-Size Sheave, 5 Groove, C Section, 7" P.D.
6C60-3-3/8	Bored-To-Size Sheave, 6 Groove, C Section, 6" P.D.
6C70-3-3/8	Bored-To-Size Sheave, 6 Groove, C Section, 7" P.D.
S9.1/4	QD Bushing 9.1/4 Bore Size

Cast Iron Sheaves - Heavy Duty
Bushed, One and Two Groove
A-B DST Sheaves
Order part number size
Example: 1B34P1



For A, AX, B & BX V-Belts.
See pages 102-108.
Order DST bushings separately
Stock Bushings Located
on Pages 89-90.

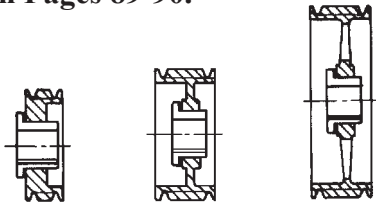

Type 1 Solid Type 2 Web Type 3 Spoke

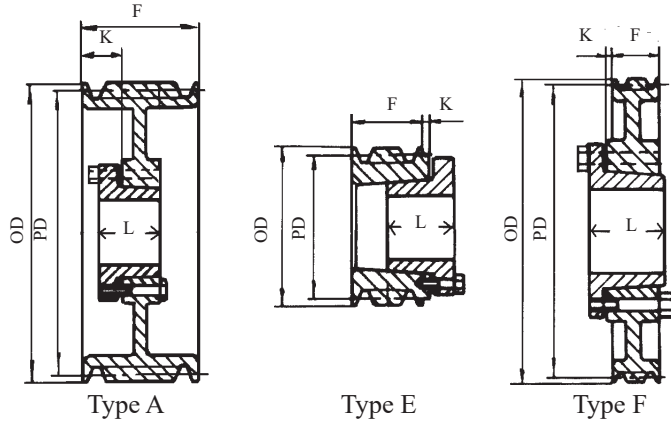

O.D.	P.D.		1 Groove F = 1						2 Groove F = 1 3/4					
	A	B	Part No.	Bush	Type	K	L	WT.	Part No.	Bush	Type	K	L	WT.
3.75	3.00	3.40	1B34P1	P1	E-1	0	1 15/16	2.0	2B34P1	P1	E-1	7/16	1 15/16	2.9
3.95	3.20	3.60	1B36P1	P1	E-1	0	1 15/16	2.3	2B36P1	P1	E-1	7/16	1 15/16	3.8
4.15	3.40	3.80	1B38P1	P1	E-1	0	1 15/16	2.6	2B38P1	P1	E-1	0	1 15/16	3.0
4.35	3.60	4.00	1B40P1	P1	F-1	0	1 15/16	2.1	2B40P1	P1	E-1	0	1 15/16	3.8
4.55	3.80	4.20	1B42P1	P1	F-1	0	1 15/16	2.4	2B42P1	P1	E-1	0	1 15/16	3.9
4.75	4.00	4.40	1B44P1	P1	F-1	0	1 15/16	2.8	2B44P1	P1	A-1	7/16	1 15/16	3.9
4.95	4.20	4.60	1B46P1	P1	F-1	0	1 15/16	3.1	2B46P1	P1	A-1	7/16	1 15/16	4.5
5.15	4.40	4.80	1B48P1	P1	F-1	0	1 15/16	3.5	2B48P1	P1	A-1	7/16	1 15/16	5.3
5.35	4.60	5.00	1B50P1	P1	F-1	0	1 15/16	3.9	2B50P1	P1	A-1	7/16	1 15/16	5.6
5.55	4.80	5.20	1B52P1	P1	F-1	0	1 15/16	4.1	2B52P1	P1	A-1	7/16	1 15/16	6.1
5.75	5.00	5.40	1B54P1	P1	F-1	0	1 15/16	4.6	2B54P1	P1	A-1	7/16	1 15/16	6.5
5.95	5.20	5.60	1B56P1	P1	F-1	0	1 15/16	5.1	2B56P1	P1	A-1	7/16	1 15/16	7.4
6.15	5.40	5.80	1B58P1	P1	F-1	0	1 15/16	5.6	2B58P1	P1	A-1	7/16	1 15/16	8.0
6.35	5.60	6.00	1B60P1	P1	F-2	0	1 15/16	6.0	2B60P1	P1	A-1	7/16	1 15/16	8.9
6.55	5.80	6.20	1B62P1	P1	F-2	0	1 15/16	5.5	2B62P1	P1	A-2	7/16	1 15/16	7.6
6.75	6.00	6.40	1B64P1	P1	F-2	0	1 15/16	5.8	2B64P1	P1	A-2	7/16	1 15/16	7.8
6.95	6.20	6.60	1B66P1	P1	F-2	0	1 15/16	5.9	2B66P1	P1	A-2	7/16	1 15/16	8.3
7.15	6.40	6.80	1B68P1	P1	F-2	0	1 15/16	6.1	2B68P1	P1	A-2	7/16	1 15/16	8.8
7.35	6.60	7.00	1B70P1	P1	F-2	5/32	1 15/16	6.4	2B70Q1	Q1	A-2	0	2 1/2	11.1
7.75	7.00	7.40	1B74P1	P1	F-2	5/32	1 15/16	7.3	2B74Q1	Q1	A-2	0	2 1/2	11.5
8.35	7.60	8.00	1B80P1	P1	F-2	5/32	1 15/16	7.8	2B80Q1	Q1	A-2	0	2 1/2	12.8
8.95	8.20	8.60	1B86P1	P1	F-2	5/32	1 15/16	8.6	2B86Q1	Q1	A-2	0	2 1/2	16.0
9.35	8.60	9.00	1B90P1	P1	F-2	5/32	1 15/16	8.9	2B90Q1	Q1	A-2	0	2 1/2	15.1
9.75	9.00	9.40	1B94P1	P1	F-2	5/32	1 15/16	9.1	2B94Q1	Q1	A-2	0	2 1/2	15.5
11.35	10.60	11.00	1B110P1	P1	F-3	5/32	1 15/16	11.1	2B110Q1	Q1	A-2	0	2 1/2	18.9
12.75	12.00	12.40	1B124Q1	Q1	F-3	3/8	2 1/2	17.8	2B124Q1	Q1	A-3	0	2 1/2	21.1
13.95	13.20	13.60	1B136Q1	Q1	F-3	3/8	2 1/2	18.2	2B136Q1	Q1	A-3	0	2 1/2	23.0
15.75	15.00	15.40	1B154Q1	Q1	F-3	3/8	2 1/2	20.3	2B154Q1	Q1	A-3	0	2 1/2	24.8
16.35	15.60	16.00	1B160Q1	Q1	F-3	3/8	2 1/2	22.0	2B160Q1	Q1	A-3	0	2 1/2	27.0
18.75	18.00	18.40	1B184Q1	Q1	F-3	3/8	2 1/2	27.5	2B184Q1	Q1	A-3	0	2 1/2	32.3
20.35	19.60	20.00	1B200Q1	Q1	F-3	3/8	2 1/2	27.2	2B200Q1	Q1	A-3	0	2 1/2	42.3
25.35	24.60	25.00	1B250Q1	Q1	F-3	3/8	2 1/2	42.4	2B250Q1	Q1	A-3	0	2 1/2	50.3
30.35	29.60	30.00							2B300Q1	Q1	A-3	0	2 1/2	68.8

Note: Cast iron sheaves may not exceed 6500 FPM. This speed **DOES NOT** specify if dynamic balancing (2 plane) is required. Contact customer service to verify whether dynamic balancing is required.

DST Bushing Sheaves

Cast Iron Sheaves - **Heavy Duty**
Bushed, **Three and Four Groove**
A-B DST Sheaves
Order part number size
Example: 3B34P2



For A, AX, B & BX V-Belts.

See pages 102-108.

Order DST bushings separately
Stock Bushings Located
on Pages 89-90.



Type 1
Solid



Type 2
Web

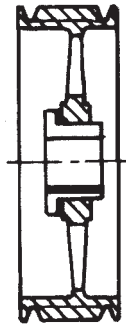

Type 3
Spoke

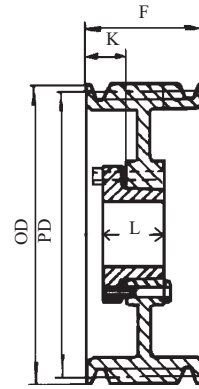

Type A

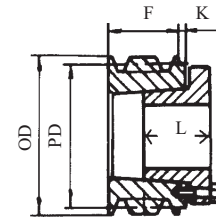

Type E

P.D.			3 Groove F = 2 1/2						4 Groove F = 3 1/4					
O.D.	A	B	Part No.	Bush	Type	K	L	WT.	Part No.	Bush	Type	K	L	WT.
3.75	3.00	3.40	3B34P2	P2	E-1	7/16	2 15/16	3.8	4B34P2	P2	E-1	7/16	2 15/16	4.5
3.95	3.20	3.60	3B36P2	P2	E-1	7/16	2 15/16	4.4	4B36P2	P2	E-1	7/16	2 15/16	5.3
4.15	3.40	3.80	3B38P1	P1	E-1	0	1 15/16	3.8	4B38P1	P1	E-1	0	1 15/16	4.8
4.35	3.60	4.00	3B40P1	P1	E-1	0	1 15/16	4.5	4B40P1	P1	E-1	0	1 15/16	5.5
4.55	3.80	4.20	3B42P1	P1	E-1	0	1 15/16	4.9	4B42P1	P1	E-1	0	1 15/16	5.9
4.75	4.00	4.40	3B44P1	P1	A-1	5/8	1 15/16	5.1	4B44P1	P1	A-2	5/8	1 15/16	6.5
4.95	4.20	4.60	3B46P1	P1	A-2	5/8	1 15/16	6.0	4B46P1	P1	A-2	5/8	1 15/16	7.1
5.15	4.40	4.80	3B48P1	P1	A-2	5/8	1 15/16	6.3	4B48P1	P1	A-2	5/8	1 15/16	7.5
5.35	4.60	5.00	3B50P1	P1	A-2	5/8	1 15/16	6.9	4B50P1	P1	A-2	5/8	1 15/16	8.3
5.55	4.80	5.20	3B52P1	P1	A-2	5/8	1 15/16	7.5	4B52P1	P1	A-2	5/8	1 15/16	9.1
5.75	5.00	5.40	3B54P1	P1	A-2	5/8	1 15/16	8.3	4B54P1	P1	A-2	5/8	1 15/16	9.6
5.95	5.20	5.60	3B56P1	P1	A-2	5/8	1 15/16	9.0	4B56P1	P1	A-2	5/8	1 15/16	10.6
6.15	5.40	5.80	3B58P1	P1	A-2	5/8	1 15/16	9.6	4B58P1	P1	A-2	5/8	1 15/16	11.6
6.35	5.60	6.00	3B60P1	P1	A-2	5/8	1 15/16	10.5	4B60P1	P1	A-2	5/8	1 15/16	11.9
6.55	5.80	6.20	3B62P1	P1	A-2	5/8	1 15/16	9.4	4B62P1	P1	A-2	5/8	1 15/16	11.1
6.75	6.00	6.40	3B64P1	P1	A-2	5/8	1 15/16	9.5	4B64P1	P1	A-2	5/8	1 15/16	11.8
6.95	6.20	6.60	3B66P1	P1	A-2	5/8	1 15/16	10.0	4B66P1	P1	A-2	5/8	1 15/16	12.0
7.15	6.40	6.80	3B68P1	P1	A-2	5/8	1 15/16	10.4	4B68P1	P1	A-2	5/8	1 15/16	12.5
7.35	6.60	7.00	3B70Q1	Q1	A-1	3/8	2 1/2	13.0	4B70Q1	Q1	A-2	3/4	2 1/2	15.3
7.75	7.00	7.40	3B74Q1	Q1	A-2	3/8	2 1/2	13.3	4B74Q1	Q1	A-2	3/4	2 1/2	15.3
8.35	7.60	8.00	3B80Q1	Q1	A-2	3/8	2 1/2	15.3	4B80Q1	Q1	A-2	3/4	2 1/2	17.0
8.95	8.20	8.60	3B86Q1	Q1	A-2	3/8	2 1/2	18.9	4B86Q1	Q1	A-2	3/4	2 1/2	20.8
9.35	8.60	9.00	3B90Q1	Q1	A-2	3/8	2 1/2	18.1	4B90Q1	Q1	A-2	3/4	2 1/2	20.6
9.75	9.00	9.40	3B94Q1	Q1	A-2	3/8	2 1/2	18.0	4B94Q1	Q1	A-2	3/4	2 1/2	20.1
11.35	10.60	11.00	3B110Q1	Q1	A-2	3/8	2 1/2	21.3	4B110Q1	Q1	A-2	3/4	2 1/2	25.8
12.75	12.00	12.40	3B124Q1	Q1	A-3	3/8	2 1/2	25.4	4B124Q1	Q1	A-3	3/4	2 1/2	27.5
13.95	13.20	13.60	3B136Q1	Q1	A-3	3/8	2 1/2	27.4	4B136Q1	Q1	A-3	3/4	2 1/2	31.5
15.75	15.00	15.40	3B154Q1	Q1	A-3	3/8	2 1/2	29.8	4B154Q1	Q1	A-3	3/4	2 1/2	36.0
16.35	15.60	16.00	3B160Q1	Q1	A-3	3/8	2 1/2	32.0	4B160Q1	Q1	A-3	3/4	2 1/2	39.0
18.75	18.00	18.40	3B184Q1	Q1	A-3	3/8	2 1/2	37.8	4B184Q1	Q1	A-3	3/4	2 1/2	44.8
20.35	19.60	20.00	3B200Q1	Q1	A-3	3/8	2 1/2	49.9	4B200Q1	Q1	A-3	3/4	2 1/2	57.0
25.35	24.60	25.00	3B250Q1	Q1	A-3	3/8	2 1/2	61.0	4B250Q1	Q1	A-3	3/4	2 1/2	69.5
30.35	29.60	30.00	3B300Q1	Q1	A-3	3/8	2 1/2	78.5	4B300Q1	Q1	A-3	3/4	2 1/2	90.8
38.35	37.60	38.00	3B380Q1	Q1	A-3	3/8	2 1/2	110.0	4B380Q1	Q1	A-3	3/4	2 1/2	125.0

Note: Cast iron sheaves may not exceed 6500 FPM. This speed **DOES NOT** specify if dynamic balancing (2 plane) is required. Contact customer service to verify whether dynamic balancing is required.

Cast Iron Sheaves - **Heavy Duty**
Bushed, **One and Two Groove**
A-B TB Sheaves
Order part number size
Example: 1B34-1210



For A, AX, B & BX V-Belts.
See pages 102-108.
Order TB bushings separately
Stock Bushings Located
on Pages 87-88.

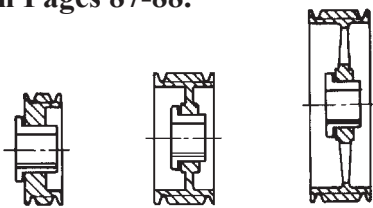

Type 1 Solid
Type 2 Web
Type 3 Spoke

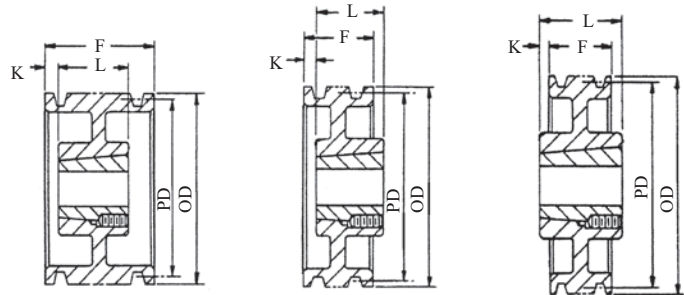

Type A Type E Type F

O.D.	P.D.		1 Groove F = 1B34-1210 THRU 1B154-2517 = 1 1B184-2517 = 1 1/8						2 Groove F = 1 3/4					
	A	B	Part No.	Bush	Type	K	L	WT.	Part No.	Bush	Type	K	L	WT.
3.75	3.00	3.40	1B34-1210	1210	A-1	0	1	2.2	2B34-1210	1210	A-1	3/4	1	2.9
3.95	3.20	3.60	1B36-1210	1210	A-1	0	1	2.6	2B36-1210	1210	A-1	3/4	1	3.8
4.15	3.40	3.80	1B38-1610	1610	A-1	0	1	2.8	2B38-1610	1610	A-1	3/4	1	3.0
4.35	3.60	4.00	1B40-1610	1610	A-1	0	1	3.0	2B40-1610	1610	A-1	3/4	1	3.8
4.55	3.80	4.20	1B42-1610	1610	A-1	0	1	3.5	2B42-1610	1610	A-1	3/4	1	3.9
4.75	4.00	4.40	1B44-1610	1610	A-1	0	1	3.8	2B44-1610	1610	A-1	3/4	1	3.9
4.95	4.20	4.60	1B46-1610	1610	A-1	0	1	4.0	2B46-1610	1610	A-1	3/4	1	4.5
5.15	4.40	4.80	1B48-1610	1610	A-1	0	1	4.5	2B48-1610	1610	A-1	3/4	1	5.3
5.35	4.60	5.00	1B50-1610	1610	A-1	0	1	4.8	2B50-1610	1610	A-1	3/4	1	5.6
5.55	4.80	5.20	1B52-1610	1610	A-1	0	1	5.0	2B52-1610	1610	A-1	3/4	1	6.1
5.75	5.00	5.40	1B54-1610	1610	A-1	0	1	5.5	2B54-1610	1610	A-1	3/4	1	6.5
5.95	5.20	5.60	1B56-1610	1610	A-1	0	1	6.0	2B56-1610	1610	A-1	3/4	1	7.4
6.15	5.40	5.80	1B58-1610	1610	A-1	0	1	6.3	2B58-1610	1610	A-1	3/4	1	8.0
6.35	5.60	6.00	1B60-1610	1610	A-1	0	1	6.7	2B60-1610	1610	A-1	3/4	1	8.9
6.55	5.80	6.20	1B62-1610	1610	A-1	0	1	7.0	2B62-1610	1610	A-1	3/4	1	7.6
6.75	6.00	6.40	1B64-1610	1610	A-1	0	1	8.0	2B64-1610	1610	A-1	3/4	1	7.8
6.95	6.20	6.60	1B66-1610	1610	A-1	0	1	8.5	2B66-1610	1610	A-1	3/4	1	8.3
7.15	6.40	6.80	1B68-1610	1610	A-1	0	1	9.0	2B68-1610	1610	A-1	3/4	1	8.8
7.75	7.00	7.40	1B74-2517	2517	E-1	0	1 3/4	9.4	2B74-2517	2517	A-1	0	1 3/4	11.5
8.95	8.20	8.60	1B86-2517	2517	E-2	0	1 3/4	12.0	2B86-2517	2517	A-2	0	1 3/4	16.0
9.75	9.00	9.40	1B94-2517	2517	E-2	0	1 3/4	14.0	2B94-2517	2517	A-2	0	1 3/4	15.5
11.35	10.60	11.00	1B110-2517	2517	E-3	0	1 3/4	18.0	2B110-2517	2517	A-3	0	1 3/4	18.9
12.75	12.00	12.40	1B124-2517	2517	F-3	1/4	1 3/4	18.5	2B124-2517	2517	A-3	0	1 3/4	21.1
15.75	15.00	15.40	1B154-2517	2517	F-3	1/4	1 3/4	19.0	2B154-2517	2517	A-3	0	1 3/4	24.8
18.75	18.00	18.40	1B184-2517	2517	F-3	3/16	1 3/4	24.0	2B184-2517	2517	A-3	0	1 3/4	32.3
20.35	19.60	20.00							2B200-3020	3020	F-3	0	2	42.3
25.35	24.60	25.00							2B250-3020	3020	F-3	0	2	50.3
30.35	29.60	30.00							2B300-3020	3020	F-3	0	2	68.8

Note: Cast iron sheaves may not exceed 6500 FPM. This speed **DOES NOT** specify if dynamic balancing (2 plane) is required. Contact customer service to verify whether dynamic balancing is required.

TB Bushing Sheaves

Cast Iron Sheaves - Heavy Duty
Bushed, **Three and Four Groove**
A-B TB Sheaves
Order part number size
Example: 3B34-1210



For A, AX, B & BX V-Belts.
See pages 102-108.
Order TB bushings separately
Stock Bushings Located
on Pages 87-88.

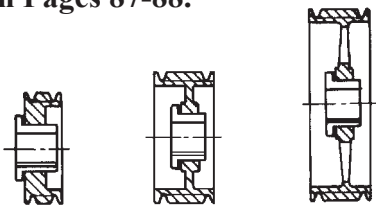

Type 1 Solid Type 2 Web Type 3 Spoke

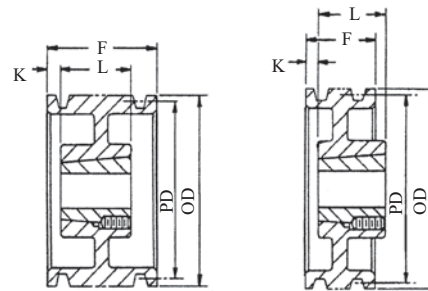

Type A Type E

O.D.	P.D.		3 Groove F = 2 1/2						4 Groove F = 3 1/4					
	A	B	Part No.	Bush	Type	K	L	WT.	Part No.	Bush	Type	K	L	WT.
3.75	3.00	3.40	3B34-1210	1210	A-1	1 1/2	1	3.0	4B34-1210	1210	A-1	2 1/4	1	3.0
3.95	3.20	3.60	3B36-1210	1210	A-1	1 1/2	1	3.5	4B36-1210	1210	A-1	2 1/4	1	3.5
4.15	3.40	3.80	3B38-1610	1610	A-1	1 1/2	1	4.0	4B38-1610	1610	A-1	2 1/4	1	4.0
4.35	3.60	4.00	3B40-1610	1610	A-1	1 1/2	1	5.0	4B40-1610	1610	A-1	2 1/4	1	5.0
4.55	3.80	4.20	3B42-1610	1610	A-1	1 1/2	1	6.0	4B42-1610	1610	A-1	2 1/4	1	5.5
4.75	4.00	4.40	3B44-1610	1610	A-1	1 1/2	1	6.5	4B44-1610	1610	A-1	2 1/4	1	6.0
4.95	4.20	4.60	3B46-1610	1610	A-1	1 1/2	1	7.0	4B46-1610	1610	A-1	2 1/4	1	7.0
5.15	4.40	4.80	3B48-1610	1610	A-1	1 1/2	1	8.0	4B48-1610	1610	A-1	2 1/4	1	8.0
5.35	4.60	5.00	3B50-1610	1610	A-1	1 1/2	1	8.5	4B50-2517	2517	A-1	1 1/2	1 3/4	8.5
5.55	4.80	5.20	3B52-1610	1610	A-1	1 1/2	1	9.0	4B52-2517	2517	A-1	1 1/2	1 3/4	9.0
5.75	5.00	5.40	3B54-2517	2517	A-1	1 1/2	1 3/4	9.5	4B54-2517	2517	A-1	1 1/2	1 3/4	9.5
5.95	5.20	5.60	3B56-2517	2517	A-1	1 1/2	1 3/4	10.0	4B56-2517	2517	A-1	1 1/2	1 3/4	10.0
6.15	5.40	5.80	3B58-2517	2517	A-1	3/4	1 3/4	10.5	4B58-2517	2517	A-1	1 1/2	1 3/4	12.0
6.35	5.60	6.00	3B60-2517	2517	A-1	3/4	1 3/4	11.0	4B60-2517	2517	A-1	1 1/2	1 3/4	12.5
6.55	5.80	6.20	3B62-2517	2517	A-1	3/4	1 3/4	11.5	4B62-2517	2517	A-1	1 1/2	1 3/4	13.0
6.75	6.00	6.40	3B64-2517	2517	A-1	3/4	1 3/4	12.0	4B64-2517	2517	A-1	1 1/2	1 3/4	14.0
6.95	6.20	6.60	3B66-2517	2517	A-1	3/4	1 3/4	12.3	4B66-2517	2517	A-1	1 1/2	1 3/4	15.0
7.15	6.40	6.80	3B68-2517	2517	A-1	3/4	1 3/4	12.8	4B68-2517	2517	A-1	1 1/2	1 3/4	16.0
7.75	7.00	7.40	3B74-2517	2517	A-1	3/4	1 3/4	16.0	4B74-2517	2517	A-1	1 1/2	1 3/4	20.0
8.95	8.20	8.60	3B86-2517	2517	A-2	3/4	1 3/4	19.0	4B86-2517	2517	A-2	1 1/2	1 3/4	21.0
9.75	9.00	9.40	3B94-2517	2517	A-2	3/4	1 3/4	21.0	4B94-2517	2517	A-2	1 1/2	1 3/4	23.0
11.35	10.60	11.00	3B110-2517	2517	A-3	3/4	1 3/4	24.0	4B110-2517	2517	A-3	1 1/2	1 3/4	28.0
12.75	12.00	12.40	3B124-2517	2517	A-3	0	1 3/4	28.0	4B124-2517	2517	A-3	3/8	1 3/4	34.0
15.75	15.00	15.40	3B154-2517	2517	A-3	0	1 3/4	30.0	4B154-2517	2517	A-3	3/8	1 3/4	42.0
18.75	18.00	18.40	3B184-2517	2517	A-3	0	1 3/4	44.0	4B184-2517	2517	A-3	1/2	1 3/4	53.0
20.35	19.60	20.00	3B200-3020	3020	A-3	0	2	58.0	4B200-3030	3030	A-3	1/2	3	63.0
25.35	24.60	25.00	3B250-3020	3020	A-3	0	2	74.0	4B250-3030	3030	A-3	0	3	80.0
30.35	29.60	30.00	3B300-3020	3020	A-3	0	2	84.0	4B300-3030	3030	A-3	0	3	100.0
38.35	37.60	38.00	3B380-3020	3020	E-3	0	2	135.0	4B380-3030	3030	A-3	0	3	142.0

Note: Cast iron sheaves may not exceed 6500 FPM. This speed **DOES NOT** specify if dynamic balancing (2 plane) is required. Contact customer service to verify whether dynamic balancing is required.

Cast Iron Sheaves - Heavy Duty
Bushed, **One and Two Groove**
3V TB Sheaves
Order part number size
Example: 1/3V265-1108



For 3V & 3VX V-Belts.
See pages 113-114
Order TB bushings separately
Stock Bushings Located
on Pages 87-88.

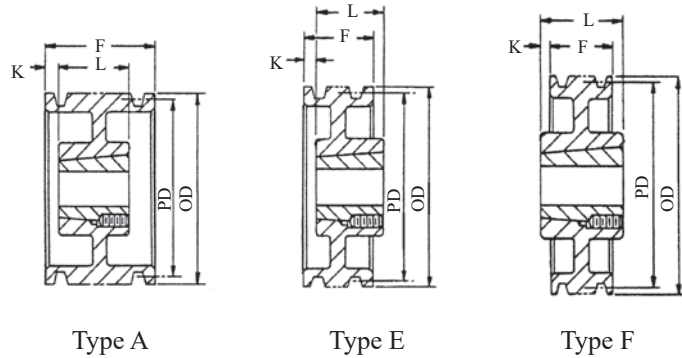
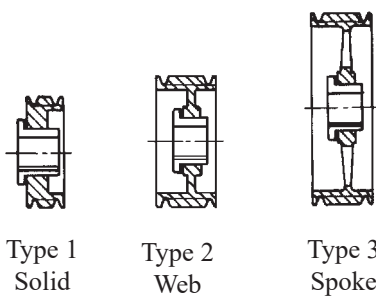

Diameters		1 Groove F = 11/16 1/3V 800-2517 & 1/3V1060-2517 F=3/4 1/3V1400-2517 & 1/3V1900-3020 F=13/16						2 Groove F = 1 3/32					
O.D.	P.D.	Part No.	Bush	Type	K	L	WT.	Part No.	Bush	Type	K	L	WT.
2.65	2.60	1/3V265-1108	1108	F-1	3/16	7/8	.8	2/3V265-1108	1108	A-1	7/32	7/8	.8
2.80	2.75	1/3V280-1108	1108	F-1	3/16	7/8	.9	2/3V280-1108	1108	A-1	7/32	7/8	.9
3.00	2.95	1/3V300-1108	1108	F-1	3/16	7/8	1.0	2/3V300-1210	1210	A-1	3/32	1	1.4
3.15	3.10	1/3V315-1108	1108	F-1	3/16	7/8	1.3	2/3V315-1210	1210	A-1	3/32	1	1.6
3.35	3.30	1/3V335-1610	1610	E-1	0	1	1.5	2/3V335-1610	1610	A-1	3/32	1	1.7
3.65	3.60	1/3V365-1610	1610	E-1	0	1	2.0	2/3V365-1610	1610	A-1	3/32	1	2.0
4.12	4.07	1/3V412-1610	1610	E-1	0	1	2.3	2/3V412-1610	1610	A-1	3/32	1	2.1
4.50	4.45	1/3V450-1610	1610	E-1	0	1	3.0	2/3V450-1610	1610	A-1	3/32	1	2.7
4.75	4.70	1/3V475-1610	1610	E-1	0	1	3.3	2/3V475-1610	1610	A-1	3/32	1	3.0
5.00	4.95	1/3V500-1610	1610	E-1	0	1	3.5	2/3V500-1610	1610	A-1	3/32	1	4.0
5.30	5.25	1/3V530-1610	1610	E-1	0	1	3.8	2/3V530-1610	1610	A-1	3/32	1	5.0
5.60	5.55	1/3V560-1610	1610	E-2	0	1	4.0	2/3V560-1610	1610	A-2	3/32	1	6.0
6.00	5.95	1/3V600-1610	1610	E-2	0	1	5.0	2/3V600-1610	1610	A-2	3/32	1	7.0
6.50	6.45	1/3V650-1610	1610	E-2	0	1	6.0	2/3V650-1610	1610	A-2	3/32	1	8.0
6.90	6.85	1/3V690-1610	1610	E-2	0	1	7.0	2/3V690-1610	1610	A-2	3/32	1	9.0
8.00	7.95	1/3V800-2517	2517	E-2	0	1 3/4	9.0	2/3V800-2517	2517	E-2	0	1 3/4	10.0
10.60	10.55	1/3V1060-2517	2517	E-3	0	1 3/4	13.0	2/3V1060-2517	2517	E-3	0	1 3/4	14.0
14.00	13.95	1/3V1400-2517	2517	E-3	0	1 3/4	15.0	2/3V1400-2517	2517	E-3	0	1 3/4	18.0
19.00	18.95	1/3V1900-3020	3020	E-3	0	2	27.0	2/3V1900-3020	3020	E-3	0	2	32.0
25.00	24.95							2/3V2500-3020	3020	F-3	1/8	2	45.0

Note: Cast iron sheaves may not exceed 6500 FPM.
This speed **DOES NOT** specify if dynamic balancing
(2 plane) is required. Contact customer service to
verify whether dynamic balancing is required.

TB Bushing Sheaves

Cast Iron Sheaves - Heavy Duty
Bushed, Three and Four Groove
3V TB Sheaves
Order part number size
Example: 3/3V265-1108

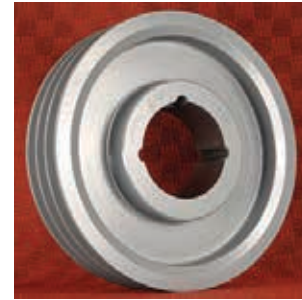

For 3V & 3VX V-Belts.
See pages 113-114
Order TB bushings separately
Stock Bushings Located
on Pages 87-88.

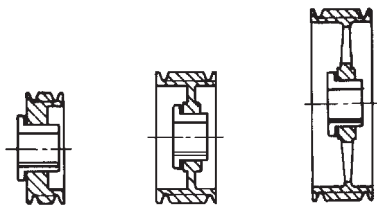

Type 1 Solid
Type 2 Web
Type 3 Spoke

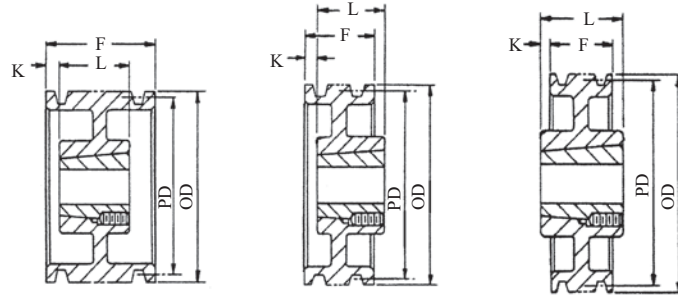

Type A
Type E
Type F

Diameters		3 Groove F = 1 1/2						4 Groove F = 1 29/32					
O.D.	P.D.	Part No.	Bush	Type	K	L	WT.	Part No.	Bush	Type	K	L	WT.
2.65	2.60	3/3V265-1108	1108	A-1	5/8	7/8	1.0	4/3V265-1108	1108	A-1	1 1/32	7/8	1.2
2.80	2.75	3/3V280-1108	1108	A-1	5/8	7/8	1.1	4/3V280-1108	1108	A-1	1 1/32	7/8	1.3
3.00	2.95	3/3V300-1210	1210	A-1	1/2	1	1.8	4/3V300-1210	1210	A-1	29/32	1	2.1
3.15	3.10	3/3V315-1210	1210	A-1	1/2	1	2.0	4/3V315-1210	1210	A-1	29/32	1	2.2
3.35	3.30	3/3V335-1610	1610	A-1	1/2	1	2.3	4/3V335-1610	1610	A-1	29/32	1	2.4
3.65	3.60	3/3V365-1610	1610	A-1	1/2	1	2.6	4/3V365-1610	1610	A-1	29/32	1	2.8
4.12	4.07	3/3V412-1610	1610	A-1	1/2	1	3.0	4/3V412-1610	1610	A-1	29/32	1	3.0
4.50	4.45	3/3V450-1610	1610	A-1	1/2	1	3.2	4/3V450-1610	1610	A-1	29/32	1	4.0
4.75	4.70	3/3V475-1610	1610	A-1	1/2	1	4.0	4/3V475-1610	1610	A-1	29/32	1	5.0
5.00	4.95	3/3V500-1610	1610	A-1	1/2	1	4.5	4/3V500-1610	1610	A-1	29/32	1	5.5
5.30	5.25	3/3V530-1610	1610	A-1	1/2	1	5.0	4/3V530-1610	1610	A-1	29/32	1	6.0
5.60	5.55	3/3V560-1610	1610	A-1	1/2	1	6.0	4/3V560-1610	1610	A-1	29/32	1	7.0
6.00	5.95	3/3V600-2517	2517	E-1	0	1 3/4	7.0	4/3V600-2517	2517	A-1	5/32	1 3/4	8.0
6.50	6.45	3/3V650-2517	2517	E-1	0	1 3/4	9.0	4/3V650-2517	2517	A-1	5/32	1 3/4	10.0
6.90	6.85	3/3V690-2517	2517	E-1	0	1 3/4	10.0	4/3V690-2517	2517	A-1	5/32	1 3/4	12.0
8.00	7.95	3/3V800-2517	2517	E-2	0	1 3/4	15.0	4/3V800-2517	2517	A-2	5/32	1 3/4	18.0
10.60	10.55	3/3V1060-2517	2517	E-3	0	1 3/4	18.0	4/3V1060-2517	2517	A-2	5/32	1 3/4	19.0
14.00	13.95	3/3V1400-2517	2517	E-3	0	1 3/4	20.0	4/3V1400-2517	2517	A-3	0	1 3/4	22.0
19.00	18.95	3/3V1900-3020	3020	E-3	0	2	36.0	4/3V1900-3020	3020	E-3	0	2	45.0
25.00	24.95	3/3V2500-3020	3020	E-3	0	2	47.0	4/3V2500-3020	3020	E-3	0	2	63.0
33.50	33.45	3/3V3350-3020	3020	F-3	1/4	2	76.0	4/3V3350-3030	3030	F-3	35/64	3	80.0

Note: Cast iron sheaves may not exceed 6500 FPM.
This speed **DOES NOT** specify if dynamic balancing
(2 plane) is required. Contact customer service to
verify whether dynamic balancing is required.

Cast Iron Sheaves - **Heavy Duty**
Bushed, **Five and Six Groove**
3V TB Sheaves
Order part number size
Example: 5/3V475-2517

For 3V & 3VX V-Belts.
See pages 113-114
Order TB bushings separately
Stock Bushings Located
on Pages 87-88.

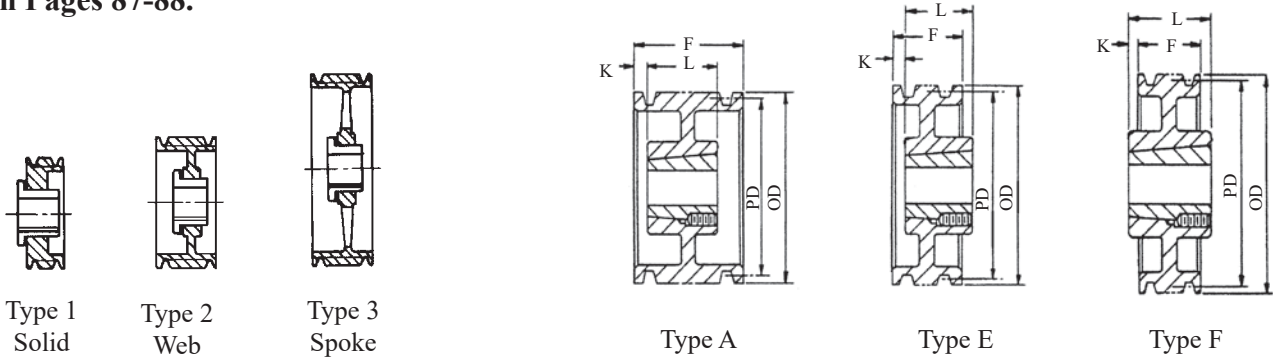

Diameters		5 Groove F = 2 5/16						6 Groove F = 2 23/32					
O.D.	P.D.	Part No.	Bush	Type	K	L	WT.	Part No.	Bush	Type	K	L	WT.
4.75	4.70	5/3V475-2517	2517	A-1	9/16	1 3/4	4.0	6/3V475-2517	2517	A-1	31/32	1 3/4	4.4
5.00	4.95	5/3V500-2517	2517	A-1	9/16	1 3/4	4.8	6/3V500-2517	2517	A-1	31/32	1 3/4	5.4
5.30	5.25	5/3V530-2517	2517	A-1	9/16	1 3/4	5.9	6/3V530-2517	2517	A-1	31/32	1 3/4	6.5
5.60	5.55	5/3V560-2517	2517	A-1	9/16	1 3/4	7.0	6/3V560-2517	2517	A-1	31/32	1 3/4	7.7
6.00	5.95	5/3V600-2517	2517	A-1	9/16	1 3/4	8.0	6/3V600-2517	2517	A-1	31/32	1 3/4	9.5
6.50	6.45	5/3V650-2517	2517	A-1	9/16	1 3/4	11.0	6/3V650-2517	2517	A-1	31/32	1 3/4	12.0
6.90	6.85	5/3V690-2517	2517	A-1	9/16	1 3/4	13.0	6/3V690-2517	2517	A-1	31/32	1 3/4	13.0
8.00	7.95	5/3V800-2517	2517	A-2	9/16	1 3/4	19.0	6/3V800-2517	2517	A-2	31/32	1 3/4	20.0
10.60	10.55	5/3V1060-2517	2517	A-2	9/16	1 3/4	21.0	6/3V1060-2517	2517	A-2	31/32	1 3/4	21.0
14.00	13.95	5/3V1400-2517	2517	A-3	0	1 3/4	30.0	6/3V1400-2517	2517	A-3	0	1 3/4	30.0
19.00	18.95	5/3V1900-3020	3020	E-3	0	2	51.0	6/3V1900-3020	3020	E-3	0	2	51.0
25.00	24.95	5/3V2500-3030	3030	E-3	0	2	76.0	6/3V2500-3030	3030	E-3	0	2	81.0
33.50	33.45	5/3V3350-3030	3030	F-3	11/32	3	97.0	6/3V3350-3030	3030	F-3	9/64	3	110.0

Note: Cast iron sheaves may not exceed 6500 FPM.
This speed **DOES NOT** specify if dynamic balancing
(2 plane) is required. Contact customer service to
verify whether dynamic balancing is required.

TB Bushing Sheaves

Cast Iron Sheaves - Heavy Duty
Bushed, Two and Three Groove
5V TB Sheaves

Order part number size
Example: 2/5V440-1610

For 5V & 5VX V-Belts.
See pages 113, 115 & 116.
Order TB bushings separately
Stock Bushings Located
on Pages 87-88.

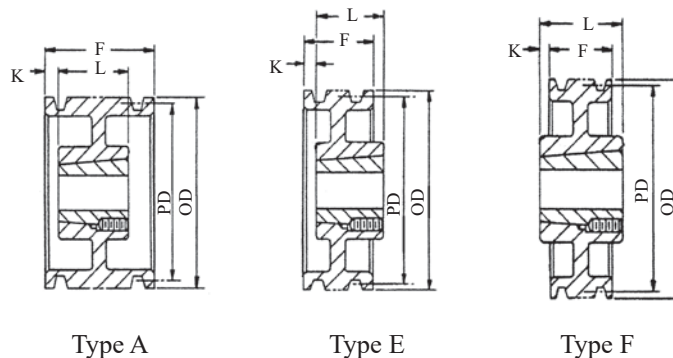
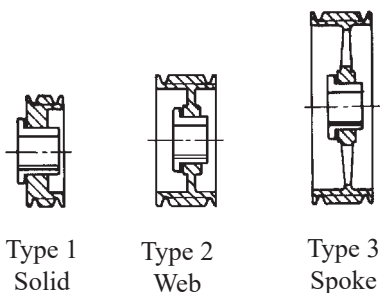

Diameters		2 Groove F = 1 11/16						3 Groove F = 2 3/8					
O.D.	P.D.	Part No.	Bush	Type	K	L	WT.	Part No.	Bush	Type	K	L	WT.
4.40	4.30	2/5V440-1610	1610	A-1	11/16	1	3.0	3/5V440-1610	1610	A-1	1 3/8	1	4.0
4.65	4.55	2/5V465-1610	1610	A-1	11/16	1	3.0	3/5V465-1610	1610	A-1	1 3/8	1	5.0
4.90	4.80	2/5V490-1610	1610	A-1	11/16	1	4.0	3/5V490-1610	1610	A-1	1 3/8	1	5.0
5.20	5.10	2/5V520-1610	1610	A-1	11/16	1	4.0	3/5V520-1610	1610	A-1	1 3/8	1	6.0
5.50	5.40	2/5V550-1610	1610	A-1	11/16	1	5.0	3/5V550-1610	1610	A-1	1 1/8	1	6.0
5.90	5.80	2/5V590-1610	1610	A-1	11/16	1	6.0	3/5V590-2517	2517	A-1	5/8	1 3/4	7.0
6.30	6.20	2/5V630-1610	1610	A-1	11/16	1	7.0	3/5V630-2517	2517	A-1	5/8	1 3/4	9.0
6.70	6.60	2/5V670-1610	1610	A-1	11/16	1	9.0	3/5V670-2517	2517	A-1	5/8	1 3/4	10.0
7.10	7.00	2/5V710-2517	2517	E-1	0	1 3/4	10.0	3/5V710-2517	2517	A-1	5/8	1 3/4	13.0
7.50	7.40	2/5V750-2517	2517	E-1	0	1 3/4	12.0	3/5V750-2517	2517	A-1	5/8	1 3/4	15.0
8.00	7.90	2/5V800-2517	2517	E-2	0	1 3/4	14.0	3/5V800-2517	2517	A-2	5/8	1 3/4	18.0
8.50	8.40	2/5V850-2517	2517	E-2	0	1 3/4	13.0	3/5V850-2517	2517	A-2	5/8	1 3/4	20.0
9.00	8.90	2/5V900-2517	2517	E-2	0	1 3/4	16.0	3/5V900-2517	2517	A-2	5/8	1 3/4	20.0
9.25	9.15	2/5V925-3020	3020	E-2	0	2	17.0	3/5V925-3020	3020	A-2	0	2	21.0
9.75	9.65	2/5V975-3020	3020	E-2	0	2	19.0	3/5V975-3020	3020	A-2	0	2	24.0
10.30	10.20	2/5V1030-3020	3020	E-2	0	2	22.0	3/5V1030-3020	3020	A-2	0	2	25.0
10.90	10.80	2/5V1090-3020	3020	E-2	0	2	24.0	3/5V1090-3020	3020	A-2	0	2	27.0
11.30	11.20	2/5V1130-3020	3020	E-2	0	2	25.0	3/5V1130-3020	3020	A-2	0	2	28.0
11.80	11.70	2/5V1180-3020	3020	E-2	0	2	26.0	3/5V1180-3020	3020	A-2	0	2	29.0
12.50	12.40	2/5V1250-3020	3020	E-2	0	2	28.0	3/5V1250-3020	3020	A-2	0	2	32.0
13.20	13.10	2/5V1320-3020	3020	E-3	0	2	21.0	3/5V1320-3020	3020	A-3	0	2	34.0
14.00	13.90	2/5V1400-3020	3020	E-3	0	2	23.0	3/5V1400-3020	3020	A-3	0	2	36.0
15.00	14.90	2/5V1500-3020	3020	E-3	0	2	26.0	3/5V1500-3020	3020	A-3	0	2	36.0
16.00	15.90	2/5V1600-3020	3020	E-3	0	2	28.0	3/5V1600-3020	3020	A-3	0	2	38.0
18.70	18.60	2/5V1870-3020	3020	E-3	0	2	40.0	3/5V1870-3020	3020	A-3	0	2	52.0
21.20	21.10	2/5V2120-3535	3535	F-3	3/8	3 1/2	45.0	3/5V2120-3535	3535	E-3	0	3 1/2	60.0
23.60	23.50	2/5V2360-3535	3535	F-3	3/8	3 1/2	56.0	3/5V2360-3535	3535	E-3	0	3 1/2	68.0
28.00	27.90	2/5V2800-3535	3535	F-3	3/8	3 1/2	68.0	3/5V2800-3535	3535	E-3	0	3 1/2	83.0
31.50	31.40							3/5V3150-3535	3535	E-3	0	3 1/2	96.0
37.50	37.40							3/5V3750-4040	4040	F-3	1/2	4	124.0
50.00	49.90							3/5V5000-4040	4040	F-3	1/2	4	186.0

Note: Cast iron sheaves may not exceed 6500 FPM.
This speed **DOES NOT** specify if dynamic balancing
(2 plane) is required. Contact customer service to
verify whether dynamic balancing is required.

Cast Iron Sheaves - **Heavy Duty**
Bushed, **Four and Five Groove**
5V TB Sheaves

Order part number size
Example: 4/5V440-1610

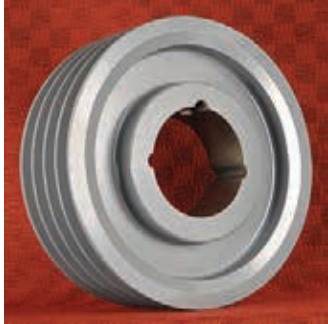

For 5V & 5VX V-Belts.
See pages 113, 115 & 116.
Order TB bushings separately
Stock Bushings Located
on Pages 87-88.

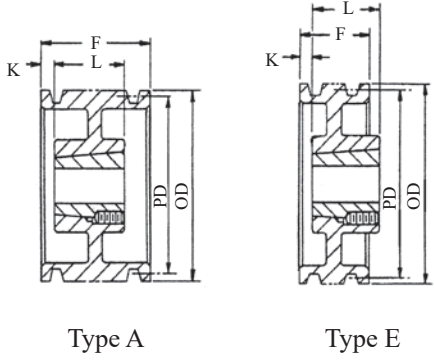
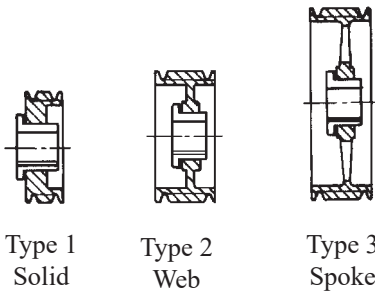

Diameters		4 Groove F = 3 1/16						5 Groove F = 3 3/4					
O.D.	P.D.	Part No.	Bush	Type	K	L	WT.	Part No.	Bush	Type	K	L	WT.
4.40	4.30	4/5V440-1610	1610	A-1	2 1/16	1	6.0						
4.65	4.55	4/5V465-1610	1610	A-1	2 1/16	1	6.0						
4.90	4.80	4/5V490-1610	1610	A-1	2 1/16	1	6.0						
5.20	5.10	4/5V520-1610	1610	A-1	1 13/16	1	7.0						
5.50	5.40	4/5V550-2517	2517	A-1	1 5/16	1 3/4	8.0						
5.90	5.80	4/5V590-2517	2517	A-1	1 5/16	1 3/4	10.0	5/5V590-2517	2517	A-1	3/4	1 3/4	11.0
6.30	6.20	4/5V630-2517	2517	A-1	1 5/16	1 3/4	11.0	5/5V630-2517	2517	A-1	3/4	1 3/4	12.0
6.70	6.60	4/5V670-2517	2517	A-1	1 5/16	1 3/4	12.0	5/5V670-2517	2517	A-1	3/4	1 3/4	13.0
7.10	7.00	4/5V710-2517	2517	A-1	1 5/16	1 3/4	15.0	5/5V710-3020	3020	A-1	1/2	2	16.0
7.50	7.40	4/5V750-2517	2517	A-1	1 5/16	1 3/4	18.0	5/5V750-3020	3020	A-1	1/2	2	19.0
8.00	7.90	4/5V800-2517	2517	A-1	1 5/16	1 3/4	21.0	5/5V800-3020	3020	A-1	1/2	2	22.0
8.50	8.40	4/5V850-2517	2517	A-1	1 5/16	1 3/4	20.0	5/5V850-3020	3020	A-1	1/2	2	26.0
9.00	8.90	4/5V900-2517	2517	A-1	1 5/16	1 3/4	22.0	5/5V900-3020	3020	A-1	1/2	2	30.0
9.25	9.15	4/5V925-3020	3020	A-2	1/2	2	27.0	5/5V925-3020	3020	A-2	1/2	2	31.0
9.75	9.65	4/5V975-3020	3020	A-2	1/2	2	31.0	5/5V975-3020	3020	A-2	1/2	2	36.0
10.30	10.20	4/5V1030-3020	3020	A-2	1/2	2	28.0	5/5V1030-3020	3020	A-2	1/2	2	33.0
10.90	10.80	4/5V1090-3020	3020	A-2	1/2	2	31.0	5/5V1090-3020	3020	A-2	1/2	2	36.0
11.30	11.20	4/5V1130-3020	3020	A-2	1/2	2	32.0	5/5V1130-3020	3020	A-2	1/2	2	38.0
11.80	11.70	4/5V1180-3020	3020	A-2	1/2	2	34.0	5/5V1180-3020	3020	A-2	1/2	2	40.0
12.50	12.40	4/5V1250-3020	3020	A-2	0	2	40.0	5/5V1250-3535	3535	A-2	0	3 1/2	54.0
13.20	13.10	4/5V1320-3020	3020	A-2	0	2	42.0	5/5V1320-3535	3535	A-2	0	3 1/2	57.0
14.00	13.90	4/5V1400-3535	3535	A-3	0	3 1/2	48.0	5/5V1400-3535	3535	A-2	0	3 1/2	57.0
15.00	14.90	4/5V1500-3535	3535	A-3	0	3 1/2	52.0	5/5V1500-3535	3535	A-3	0	3 1/2	65.0
16.00	15.90	4/5V1600-3535	3535	A-3	0	3 1/2	53.0	5/5V1600-3535	3535	A-3	0	3 1/2	70.0
18.70	18.60	4/5V1870-3535	3535	A-3	0	3 1/2	63.0	5/5V1870-3535	3535	A-3	0	3 1/2	84.0
21.20	21.10	4/5V2120-3535	3535	A-3	0	3 1/2	70.0	5/5V2120-4040	4040	E-3	0	4	81.0
23.60	23.50	4/5V2360-3535	3535	A-3	0	3 1/2	79.0	5/5V2360-4040	4040	E-3	0	4	92.0
28.00	27.90	4/5V2800-3535	3535	A-3	0	3 1/2	98.0	5/5V2800-4040	4040	E-3	0	4	115.0
31.50	31.40	4/5V3150-3535	3535	A-3	0	3 1/2	114.0	5/5V3150-4040	4040	E-3	0	4	115.0
37.50	37.40	4/5V3750-4040	4040	A-3	0	4	148.0	5/5V3750-4040	4040	E-3	0	4	190.0
50.00	49.90	4/5V5000-4040	4040	A-3	0	4	243.0	5/5V5000-4545	4545	E-3	0	4 1/2	280.0

Note: Cast iron sheaves may not exceed 6500 FPM.
This speed **DOES NOT** specify if dynamic balancing
(2 plane) is required. Contact customer service to
verify whether dynamic balancing is required.

TB Bushing Sheaves

Cast Iron Sheaves - **Heavy Duty**

Bushed, **Six Groove**

5V TB Sheaves

Order part number size

Example: 6/5V590-2517

For **5V & 5VX V-Belts**.

See pages 113, 115 & 116.

Order TB bushings separately

Stock Bushings Located

on Pages 87-88.

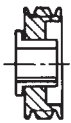

Type 1
Solid



Type 2
Web



Type 3
Spoke

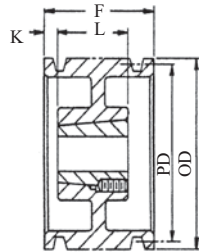

Type A

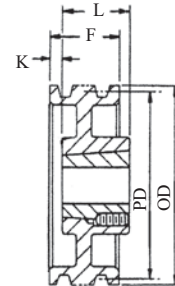

Type E

Diameters		6 Groove F = 4 7/16					
O.D.	P.D.	Part No.	Bush	Type	K	L	WT.
5.90	5.80	6/5V590-2517	2517	A-1	1	1 3/4	13.0
6.30	6.20	6/5V630-2517	2517	A-1	1	1 3/4	13.0
6.70	6.60	6/5V670-2517	2517	A-1	1	1 3/4	15.0
7.10	7.00	6/5V710-3020	3020	A-1	3/4	2	18.0
7.50	7.40	6/5V750-3020	3020	A-1	3/4	2	21.0
8.00	7.90	6/5V800-3020	3020	A-1	3/4	2	24.0
8.50	8.40	6/5V850-3020	3020	A-1	3/4	2	28.0
9.00	8.90	6/5V900-3020	3020	A-1	3/4	2	32.0
9.25	9.15	6/5V925-3535	3535	A-1	0	3 1/2	41.0
9.75	9.65	6/5V975-3535	3535	A-1	0	3 1/2	48.0
10.30	10.20	6/5V1030-3535	3535	A-1	0	3 1/2	56.0
10.90	10.80	6/5V1090-3535	3535	A-1	0	3 1/2	65.0
11.30	11.20	6/5V1130-3535	3535	A-1	0	3 1/2	53.0
11.80	11.70	6/5V1180-3535	3535	A-2	0	3 1/2	59.0
12.50	12.40	6/5V1250-3535	3535	A-2	0	3 1/2	59.0
13.20	13.10	6/5V1320-3535	3535	A-2	0	3 1/2	67.0
14.00	13.90	6/5V1400-3535	3535	A-3	0	3 1/2	67.0
15.00	14.90	6/5V1500-4040	4040	A-3	0	4	82.0
16.00	15.90	6/5V1600-4040	4040	A-3	0	4	84.0
18.70	18.60	6/5V1870-4040	4040	A-3	0	4	97.0
21.20	21.10	6/5V2120-4040	4040	A-3	0	4	91.0
23.60	23.50	6/5V2360-4040	4040	A-3	0	4	124.0
28.00	27.90	6/5V2800-4040	4040	A-3	0	4	149.0
31.50	31.40	6/5V3150-4040	4040	A-3	0	4	171.0
37.50	37.40	6/5V3750-4545	4545	E-3	0	4 1/2	214.0
50.00	49.90	6/5V5000-4545	4545	E-3	0	4 1/2	336.0

Note: Cast iron sheaves may not exceed 6500 FPM.
This speed **DOES NOT** specify if dynamic balancing
(2 plane) is required. Contact customer service to
verify whether dynamic balancing is required.

Flat Belt Pulleys

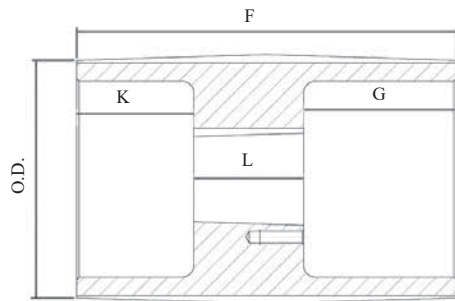

Part Number	Bushing	Dimensions					Wt.
		O.D.	F	L	K	G	
5X8FBPP2	P2	5.00	8.00	2.31	2.47	3.22	23.0
6X8FBPQ2	Q2	6.00	8.00	2.75	2.31	2.94	25.0
7X8FBPQ2	Q2	7.00	8.00	2.75	2.31	2.94	38.0
8X8FBPQ2	Q2	8.00	8.00	2.75	2.31	2.94	49.0

Note: All Flat Belt Pulleys are crowned and are grooved for self-cleaning.
Order bushing separately. (See pages 89-90)

Part Number Example: 5X8FBPP2
5" O.D. x 8" Face Width. Uses a P2 bushing.

P18L100-1108

Pulley Number of Teeth Belt Pitch Belt Width Bushing

Industry standard
nomenclature

18

3/8"

1"

1108

P24-8M-20-JA

Pulley Number of Teeth Belt Pitch Belt Width Bushing

Industry standard
nomenclature

18

8MM

20MM

JA

Note:

When PB is at the end of the part number this part comes with a plain bore and can be re-bored to meet a customer's need with a machine charge.

“L” Pitch Timing Pulley Dimensions

**For L Timing Belts.
See page 120
Order TB bushings separately
Stock Bushings Located
on Pages 87-88.**

The Timing Pulleys listed below are all stock sizes.
The figure following the type sketch letter in the “Type” column indicates the construction:
(1-Solid, 2-Web, 3-Spoked), and the letter F indicates the sprocket has flanges.

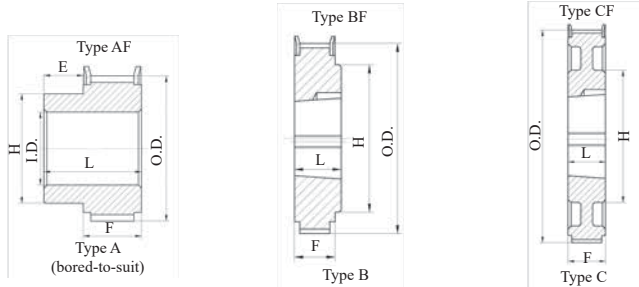

For belts 1/2 inch wide (050) * 3/8-inch pitch (L) * Face Width (F) = 3/4"												
Part Number	No. of Teeth	Pitch Dia.	O.D.		Bore	Type	Dimensions, Inches			Max. Bore No Keyway	Max. Bore Std. Keyway	Wt.
			Pulley	Flange			E	L	H			
P10L050-PB	10	1.19	1.16	1.38	MPB	A1F	9/32	1 1/64	7/8	9/16	1/2	.20
P12L050-PB	12	1.43	1.40	1.73	MPB	A1F	27/64	1 3/16	1 7/64	3/4	11/16	.34
P13L050-PB	13	1.55	1.52	1.73	MPB	A1F	27/64	1 3/16	1 7/64	3/4	11/16	.42
P14L050-PB	14	1.67	1.64	1.89	MPB	A1F	27/64	1 3/16	1 7/64	3/4	11/16	.48
P15L050-PB	15	1.79	1.76	2.01	MPB	A1F	27/64	1 3/16	1 1/4	7/8	13/16	.53
P16L050-PB	16	1.91	1.88	2.17	MPB	A1F	1/2	1 3/16	1 27/64	1 1/16	15/16	.62
P17L050-PB	17	2.03	2.00	2.24	MPB	A1F	1/2	1 1/4	1 1/2	1 1/8	1	.70
P18L050-1108	18	2.15	2.12	2.40	1108	B1F	***	7/8	1 25/32	***	1 1/8	.40
P20L050-1108	20	2.39	2.36	2.60	1108	B1F	***	7/8	1 27/32	***	1 1/8	.55
P21L050-1108	21	2.51	2.48	2.76	1108	B1F	***	7/8	1 59/64	***	1 1/8	.65
P22L050-1108	22	2.63	2.60	2.91	1108	B1F	***	7/8	2 3/32	***	1 1/8	.75
P23L050-1108	23	2.75	2.72	3.07	1108	B1F	***	7/8	2 1/8	***	1 1/8	.80
P24L050-1210	24	2.87	2.84	3.07	1210	B1F	***	1	2 9/32	***	1 1/4	.90
P25L050-1210	25	2.98	2.95	3.35	1210	B1F	***	1	2 23/64	***	1 1/4	1.00
P26L050-1210	26	3.10	3.07	3.35	1210	B1F	***	1	2 23/64	***	1 1/4	1.10
P28L050-1210	28	3.34	3.31	3.62	1210	B1F	***	1	2 31/64	***	1 1/4	1.30
P30L050-1610	30	3.58	3.55	3.74	1610	B1F	***	1	2 31/64	***	1 5/8	1.40
P32L050-1610	32	3.82	3.79	4.09	1610	B1F	***	1	2 31/64	***	1 5/8	1.65
P40L050-2012	40	4.78	4.75	5.00	2012	B1F	***	1 1/4	3 35/64	***	2	3.00
P48L050-2012	48	5.73	5.70	6.10	2012	B1F	***	1 1/4	3 35/64	***	2	4.55
P60L050-2012	60	7.16	7.13	***	2012	C2	***	1 1/4	4 21/64	***	2	6.15
P72L050-2012	72	8.59	8.56	***	2012	C2	***	1 1/4	4 21/64	***	2	9.55
P84L050-2517	84	10.03	10.00	***	2517	C2	***	1 3/4	4 59/64	***	2 1/2	13.75

PB pulleys have no keyway and no set screw.

L Timing Pulleys

“L” Pitch Timing Pulley Dimensions

The Timing Pulleys listed below are all stock sizes.

The figure following the type sketch letter in the “Type” column indicates the construction: (1-Solid, 2-Web, 3-Spoked), and the letter F indicates the sprocket has flanges.

For L Timing Belts.

See page 120

Order TB bushings separately

Stock Bushings Located

on Pages 87-88.

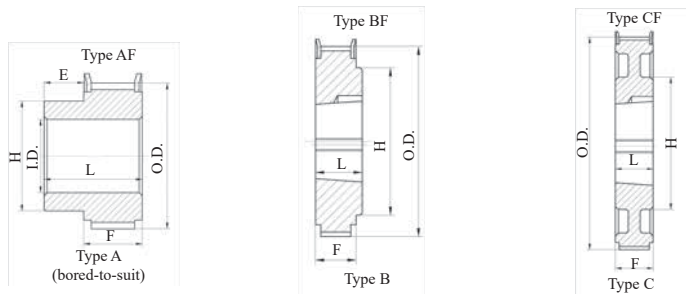

For belts 3/4 inch wide (075) * 3/8-inch pitch (L) * Face Width (F) = 1”												
Part Number	No. of Teeth	Pitch Dia.	O.D.		Bore	Type	Dimensions, Inches			Max. Bore No Keyway	Max. Bore Std. Keyway	Wt.
			Pulley	Flange			E	L	H			
P12L075-PB	12	1.43	1.40	1.73	MPB	A1F	1/2	1 1/2	1 7/64	3/4	11/16	.43
P13L075-PB	13	1.55	1.52	1.73	MPB	A1F	1/2	1 1/2	1 7/64	3/4	11/16	.50
P14L075-PB	14	1.67	1.64	1.89	MPB	A1F	1/2	1 1/2	1 7/64	3/4	11/16	.53
P15L075-PB	15	1.79	1.76	2.01	MPB	A1F	1/2	1 1/2	1 1/4	7/8	13/16	.60
P16L075-PB	16	1.91	1.88	2.13	MPB	A1F	5/8	1 5/8	1 27/64	1 1/16	15/16	.70
P17L075-PB	17	2.03	2.00	2.24	MPB	A1F	5/8	1 5/8	1 1/2	1 1/8	1	.80
P18L075-1108	18	2.15	2.12	2.36	1108	B1F	***	7/8	***	***	1 1/8	.45
P20L075-1108	20	2.39	2.36	2.60	1108	B1F	***	7/8	***	***	1 1/8	.65
P22L075-1108	22	2.63	2.60	2.80	1108	B1F	***	7/8	***	***	1 1/8	.90
P24L075-1210	24	2.87	2.84	3.07	1210	B1F	***	1	***	***	1 1/4	.90
P26L075-1210	26	3.10	3.07	3.35	1210	B1F	***	1	***	***	1 1/4	1.25
P28L075-1610	28	3.34	3.31	3.58	1610	B1F	***	1	***	***	1 5/8	1.20
P30L075-1610	30	3.58	3.55	3.82	1610	B1F	***	1	***	***	1 5/8	1.85
P32L075-1610	32	3.82	3.79	4.06	1610	B1F	***	1	***	***	1 5/8	1.85
P40L075-2012	40	4.78	4.75	5.00	2012	B1F	***	1 1/4	3 35/64	***	2	3.30
P48L075-2012	48	5.73	5.70	5.98	2012	B1F	***	1 1/4	3 35/64	***	2	5.35
P60L075-2012	60	7.16	7.13	***	2012	C2	***	1 1/4	4 21/64	***	2	6.45
P72L075-2012	72	8.59	8.56	***	2012	C2	***	1 1/4	4 21/64	***	2	9.70
P84L075-2517	84	10.03	10.00	***	2517	C2	***	1 3/4	4 59/64	***	2 1/2	14.55

PB pulleys have no keyway and no set screw.

“L” Pitch Timing Pulley Dimensions

**For L Timing Belts.
See page 120
Order TB bushings separately
Stock Bushings Located
on Pages 87-88.**

The Timing Pulleys listed below are all stock sizes.
The figure following the type sketch letter in the “Type” column indicates the construction:
(1-Solid, 2-Web, 3-Spoked), and the letter F indicates the sprocket has flanges.

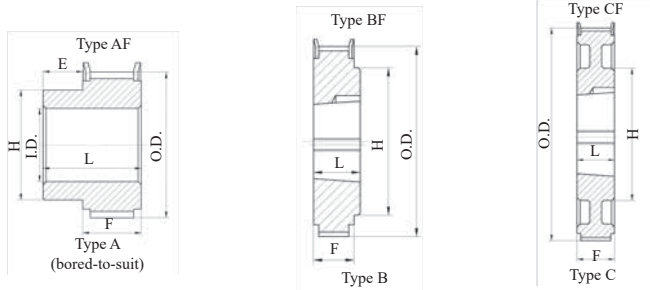

For belts 1 inch wide (100) * 3/8-inch pitch (L) * Face Width (F) = 1 1/4"												
Part Number	No. of Teeth	Pitch Dia.	O.D.		Bore	Type	Dimensions, Inches			Max. Bore No Keyway	Max. Bore Std. Keyway	Wt.
			Pulley	Flange			E	L	H			
P13L100-PB	13	1.55	1.52	1.73	MPB	A1F	33/64	1 49/64	1 7/64	3/4	11/16	.60
P14L100-PB	14	1.67	1.64	1.89	MPB	A1F	33/64	1 49/64	1 7/64	3/4	11/16	.65
P15L100-PB	15	1.79	1.76	2.01	MPB	A1F	33/64	1 49/64	1 1/4	7/8	13/16	.74
P16L100-PB	16	1.91	1.88	2.13	MPB	A1F	33/64	1 49/64	1 27/64	1 1/16	15/16	.80
P17L100-PB	17	2.03	2.00	2.24	MPB	A1F	33/64	1 49/64	1 1/2	1 1/8	1	1.00
P18L100-1108	18	2.15	2.12	2.36	1108	B1F	***	7/8	***	***	1 1/8	.55
P20L100-1108	20	2.39	2.36	2.60	1108	B1F	***	7/8	***	***	1 1/8	.80
P22L100-1108	22	2.63	2.60	2.80	1108	B1F	***	7/8	***	***	1 1/8	1.05
P24L100-1210	24	2.87	2.84	3.07	1210	B1F	***	1	***	***	1 1/4	1.25
P26L100-1210	26	3.10	3.07	3.35	1210	B1F	***	1	***	***	1 1/4	1.45
P28L100-1610	28	3.34	3.31	3.58	1610	B1F	***	1	***	***	1 5/8	1.45
P30L100-1610	30	3.58	3.55	3.82	1610	B1F	***	1	***	***	1 5/8	1.75
P32L100-1610	32	3.82	3.79	4.06	1610	B1F	***	1	***	***	1 5/8	2.15
P40L100-2012	40	4.78	4.75	5.00	2012	B1F	***	1 1/4	***	***	2	3.75
P48L100-2012	48	5.73	5.70	5.98	2012	B1F	***	1 1/4	***	***	2	6.10
P60L100-2012	60	7.16	7.13	***	2012	C2	***	1 1/4	4 21/64	***	2	6.95
P72L100-2012	72	8.59	8.56	***	2012	C2	***	1 1/4	4 21/64	***	2	10.60
P84L100-2517	84	10.03	10.00	***	2517	C2	***	1 3/4	4 59/64	***	2 1/2	15.15

PB pulleys have no keyway and no set screw.

H Timing Pulleys

“H” Pitch Timing Pulley Dimensions

The Timing Pulleys listed below are all stock sizes.

The figure following the type sketch letter in the “Type” column indicates the construction: (1-Solid, 2-Web, 3-Spoked), and the letter F indicates the sprocket has flanges.

For H Timing Belts.

See page 121

Order TB bushings separately

Stock Bushings Located

on Pages 87-88.

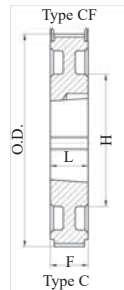
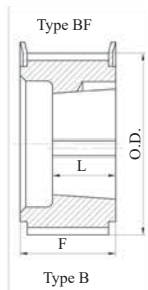

Part Number	No. of Teeth	Pitch Dia.	O.D.		Bore	Type	Dimensions, Inches		Max. Bore	Wt.
			Pulley	Flange			L	H		
P14H100-1008	14	2.23	2.18	2.40	1008	B1F	7/8	***	1	.70
P16H100-1108	16	2.54	2.49	2.76	1108	B1F	7/8	***	1 1/8	.90
P18H100-1210	18	2.86	2.81	3.07	1210	B1F	1	***	1 1/4	1.00
P20H100-1210	20	3.18	3.13	3.43	1210	B1F	1	***	1 1/4	1.45
P22H100-1610	22	3.50	3.45	3.74	1610	B1F	1	***	1 5/8	1.60
P24H100-1610	24	3.82	3.77	4.09	1610	B1F	1	***	1 5/8	2.10
P26H100-2012	26	4.14	4.09	4.45	2012	B1F	1 1/4	***	2	2.25
P28H100-2012	28	4.45	4.40	4.69	2012	B1F	1 1/4	***	2	2.95
P30H100-2012	30	4.77	4.72	5.00	2012	B1F	1 1/4	***	2	3.60
P32H100-2517	32	5.09	5.04	5.31	2517	B1F	1 3/4	4 7/16	2 1/2	4.20
P40H100-2517	40	6.36	6.31	6.65	2517	B1F	1 3/4	4 7/16	2 1/2	7.40
P48H100-2517	48	7.64	7.59	7.95	2517	B1F	1 3/4	4 7/16	2 1/2	9.95
P60H100-3020	60	9.55	9.50	***	3020	C2	2	6 7/64	3	16.45
P72H100-3020	72	11.46	11.41	***	3020	C2	2	6 7/64	3	22.75
P84H100-3020	84	13.37	13.32	***	3020	C2	2	6 7/64	3	29.90
P96H100-3020	96	15.28	15.23	***	3020	C2	2	6 7/64	3	28.75
P120H100-3020	120	19.10	19.05	***	3020	C3	2	6 7/64	3	42.25

“H” Pitch Timing Pulley Dimensions

The Timing Pulleys listed below are all stock sizes.
The figure following the type sketch letter in the “Type” column indicates the construction:
(1-Solid, 2-Web, 3-Spoked), and the letter F indicates the sprocket has flanges.

**For H Timing Belts.
See page 121
Order TB bushings separately
Stock Bushings Located
on Pages 87-88.**

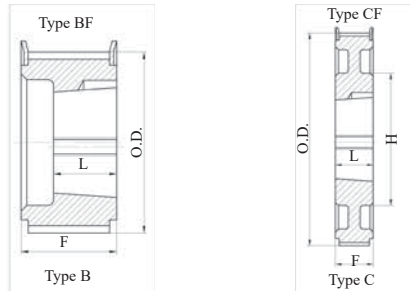

For belts 1-1/2 inches wide (150) * 1/2-inch pitch (H) Face Width (F) = 1-13/16"										
Part Number	No. of Teeth	Pitch Dia.	O.D.		Bore	Type	Dimensions, Inches		Max. Bore	Wt.
			Pulley	Flange			L	H		
P14H150-1008	14	2.23	2.18	2.40	1008	B1F	7/8	***	1	.80
P16H150-1108	16	2.55	2.49	2.76	1108	B1F	7/8	***	1 1/8	1.20
P18H150-1210	18	2.86	2.81	3.07	1210	B1F	1	***	1 1/4	1.30
P20H150-1210	20	3.18	3.13	3.43	1210	B1F	1	***	1 1/4	1.85
P22H150-1610	22	3.50	3.45	3.74	1610	B1F	1	***	1 5/8	2.10
P24H150-2012	24	3.82	3.77	4.09	2012	B1F	1 1/4	***	2	2.05
P26H150-2012	26	4.14	4.09	4.37	2012	B1F	1 1/4	***	2	2.80
P28H150-2012	28	4.45	4.40	4.69	2012	B1F	1 1/4	***	2	3.50
P30H150-2012	30	4.77	4.72	5.00	2012	B1F	1 1/4	***	2	4.30
P32H150-2517	32	5.09	5.04	5.31	2517	B1F	1 3/4	***	2 1/2	4.90
P40H150-2517	40	6.36	6.31	6.65	2517	B1F	1 3/4	***	2 1/2	8.20
P48H150-2517	48	7.64	7.59	7.95	2517	C2F	1 3/4	4 59/64	2 1/2	11.25
P60H150-3020	60	9.55	9.50	***	3020	C2	2	6 7/64	3	10.80
P72H150-3020	72	11.46	11.41	***	3020	C2	2	6 7/64	3	25.20
P84H150-3020	84	13.37	13.32	***	3020	C3	2	6 7/64	3	32.40
P96H150-3020	96	15.28	15.23	***	3020	C3	2	6 7/64	3	31.52
P120H150-3020	120	19.10	19.05	***	3020	C3	2	6 7/64	3	46.50

H Timing Pulleys

For H Timing Belts.
See page 121
Order TB bushings separately
Stock Bushings Located
on Pages 87-88.

“H” Pitch Timing Pulley Dimensions

The Timing Pulleys listed below are all stock sizes.

The figure following the type sketch letter in the “Type” column indicates the construction: (1-Solid, 2-Web, 3-Spoked), and the letter F indicates the sprocket has flanges.

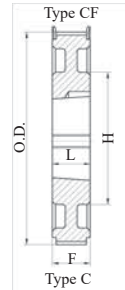
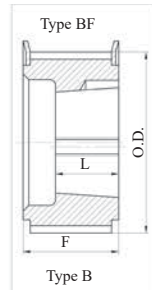

For belts 2 inches wide (200) * 1/2-inch pitch (H)						Face Width (F) = 2-11/32"				
Part Number	No. of Teeth	Pitch Dia.	O.D.		Bore	Type	Dimensions, Inches		Max. Bore	Wt.
			Pulley	Flange			L	H		
P16H200-1108	16	2.54	2.49	2.76	1108	B1F	7/8	***	1 1/8	1.50
P18H200-1215	18	2.86	2.81	3.07	1215	B1F	1 1/2	***	1 1/4	1.50
P20H200-1215	20	3.18	3.13	3.43	1215	B1F	1 1/2	***	1 1/4	2.30
P22H200-1615	22	3.50	3.45	3.74	1615	B1F	1 1/2	***	1 5/8	2.55
P24H200-2012	24	3.82	3.77	4.09	2012	B1F	1 1/4	***	2	2.45
P26H200-2012	26	4.14	4.09	4.45	2012	B1F	1 1/4	***	2	3.40
P28H200-2012	28	4.45	4.40	4.69	2012	B1F	1 1/4	***	2	4.15
P30H200-2012	30	4.77	4.72	5.00	2012	B1F	1 1/4	***	2	4.90
P32H200-2517	32	5.09	5.04	5.31	2517	B1F	1 3/4	***	2 1/2	5.75
P40H200-2517	40	6.36	6.31	6.65	2517	B1F	1 3/4	***	2 1/2	9.30
P48H200-3020	48	7.64	7.59	7.95	3020	B1F	2	***	3	16.40
P60H200-3020	60	9.55	9.50	***	3020	C2	2	6 7/64	3	20.10
P72H200-3020	72	11.46	11.41	***	3020	C2	2	6 7/64	3	27.15
P84H200-3020	84	13.37	13.32	***	3020	C3	2	6 7/64	3	34.62
P96H200-3535	96	15.28	15.23	***	3535	C3	3 1/2	6 57/64	3 1/2	43.95
P120H200-3535	120	19.10	19.05	***	3535	C3	3 1/2	6 57/64	3 1/2	58.92

“H” Pitch Timing Pulley Dimensions

For H Timing Belts.

See page 121

Order TB bushings separately

Stock Bushings Located

on Pages 87-88.

The Timing Pulleys listed below are all stock sizes.

The figure following the type sketch letter in the “Type” column indicates the construction:

(1-Solid, 2-Web, 3-Spoked), and the letter F indicates the sprocket has flanges.

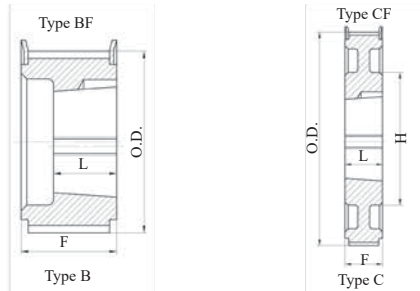

For belts 3 inches wide (300) * 1/2-inch pitch (H)					Face Width (F) = 3-3/8"					
Part Number	No. of Teeth	Pitch Dia.	O.D.		Bore	Type	Dimensions, Inches		Max. Bore	Wt.
			Pulley	Flange			L	H		
P16H300-1108	16	2.54	2.49	2.76	1108	B1F	7/8	***	1 1/8	2.00
P18H300-1215	18	2.86	2.81	3.07	1215	B1F	1 1/2	***	1 1/4	2.05
P20H300-1215	20	3.18	3.13	3.43	1215	B1F	1 1/2	***	1 1/4	3.05
P22H300-1615	22	3.50	3.45	3.74	1615	B1F	1 1/2	***	1 5/8	3.50
P24H300-2012	24	3.82	3.77	4.09	2012	B1F	1 1/4	***	2	4.05
P26H300-2012	26	4.14	4.09	4.45	2012	B1F	1 1/4	***	2	4.60
P28H300-2012	28	4.45	4.40	4.69	2012	B1F	1 1/4	***	2	5.40
P30H300-2012	30	4.77	4.72	5.00	2012	B1F	1 1/4	***	2	6.45
P32H300-2517	32	5.09	5.04	5.31	2517	B1F	1 3/4	***	2 1/2	7.25
P40H300-2517	40	6.36	6.31	6.65	2517	B1F	1 3/4	***	2 1/2	11.40
P48H300-3020	48	7.64	7.59	7.95	3020	B1F	2	***	3	19.25
P60H300-3020	60	9.55	9.50	***	3020	C2	2	6 7/64	3	22.60
P72H300-3020	72	11.46	11.41	***	3020	C2	2	6 7/64	3	30.70
P84H300-3020	84	13.37	13.32	***	3020	C3	2	6 7/64	3	37.45
P96H300-3535	96	15.28	15.23	***	3535	C3	3 1/2	6 57/64	3 1/2	51.84
P120H300-3535	120	19.10	19.05	***	3535	C3	3 1/2	6 57/64	3 1/2	75.08

5M HTD Timing Pulley Dimensions

For 5M HTD Timing Belts.

See page 122

Order QD bushings separately

Stock Bushings Located

on Pages 84-85.

The Timing Pulleys listed below are all stock sizes.

The figure following the type sketch letter in the "Type" column indicates the construction:

(1-Solid, 2-Web, 3-Spoked), and the letter F indicates the sprocket has flanges.

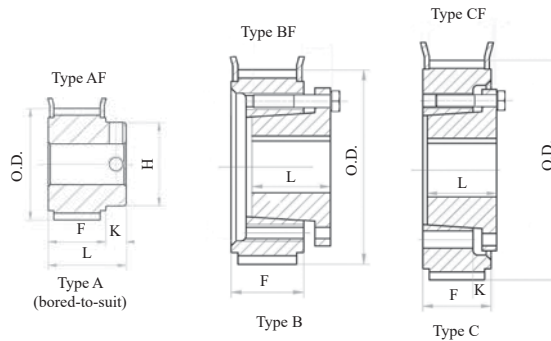

For belts 15MM wide * 5MM Pitch * Face Width (F) = 57/64"												
Part No.	No. of Teeth	Pitch Dia.	O.D.		Bore	Type	Dimensions			Max. Bore No Keyway	Max. Bore Std. Keyway	Wt.
			Pulley	Flange			L	H	K			
P32-5M-15-PB	32	2.01	1.96	2.17	MPB	A1F	1.64	1.50	0.75	1 1/8	1	0.91
P34-5M-15-PB	34	2.13	2.09	2.24	MPB	A1F	1.64	1.50	0.75	1 1/8	1	1.02
P36-5M-15-PB	36	2.26	2.21	2.40	MPB	A1F	1.64	1.50	0.75	1 1/8	1	1.14
*P38-5M-15-JA	38	2.38	2.34	2.60	JA	B1F	1.00	-	-	1 1/4	1 3/16	0.66
*P40-5M-15-JA	40	2.51	2.46	2.70	JA	B1F	1.00	-	-	1 1/4	1 3/16	0.74
*P44-5M-15-JA	44	2.76	2.71	2.91	JA	B1F	1.00	-	-	1 1/4	1 3/16	0.87
P48-5M-15-JA	48	3.01	2.97	3.27	JA	C1F	1.00	-	0.33	1 1/4	1 3/16	1.02
P52-5M-15-JA	52	3.26	3.21	3.43	JA	C1F	1.00	-	0.33	1 1/4	1 3/16	1.19
P56-5M-15-SH	56	3.51	3.47	3.74	SH	B1F	1.31	-	-	1 11/16	1 5/8	1.36
P60-5M-15-SH	60	3.76	3.72	4.02	SH	B1F	1.31	-	-	1 11/16	1 5/8	1.60
P64-5M-15-SH	64	4.01	3.97	4.25	SH	B1F	1.31	-	-	1 11/16	1 5/8	1.85
P68-5M-15-SDS	68	4.26	4.22	4.45	SDS	C1F	1.31	-	0.14	2	1 15/16	1.90
P72-5M-15-SDS	72	4.51	4.47	4.69	SDS	C1F	1.31	-	0.14	2	1 15/16	2.16
P80-5M-15-SDS	80	5.01	4.97	-	SDS	C1	1.31	-	0.14	2	1 15/16	2.73
P90-5M-15-SDS	90	5.64	5.59	-	SDS	C1	1.31	-	0.14	2	1 15/16	3.22
P112-5M-15-SDS	112	7.02	6.97	-	SDS	C1	1.31	-	0.14	2	1 15/16	4.79

* = Can only be mounted from one direction

PB pulleys have no keyway and no set screw. Rebore available upon request.

5M HTD Timing Pulley Dimensions

For 5M HTD Timing Belts.
See page 122
Order QD bushings separately
Stock Bushings Located
on Pages 84-85.

The Timing Pulleys listed below are all stock sizes.
The figure following the type sketch letter in the “Type” column indicates the construction:
(1-Solid, 2-Web, 3-Spoked), and the letter F indicates the sprocket has flanges.

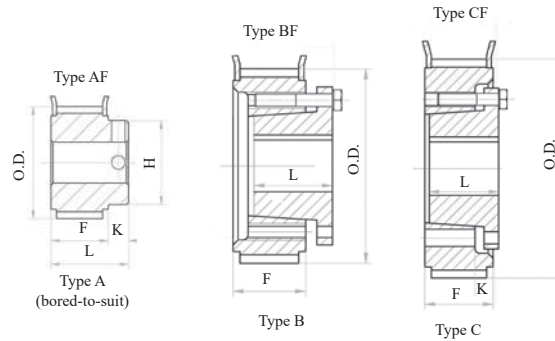

For belts 25MM wide * 5MM Pitch * Face Width (F) = 1 1/4"												
Part No.	No. of Teeth	Pitch Dia.	O.D.		Bore	Type	Dimensions			Max. Bore No Keyway	Max. Bore Std. Keyway	Wt.
			Pulley	Flange			L	H	K			
P32-5M-25-PB	32	2.01	1.96	2.17	MPB	A1F	2.03	1.50	0.75	1 1/8	1	0.97
P34-5M-25-PB	34	2.13	2.09	2.24	MPB	A1F	2.03	1.50	0.75	1 1/8	1	1.09
P36-5M-25-PB	36	2.26	2.21	2.40	MPB	A1F	2.03	1.50	0.75	1 1/8	1	1.22
*P38-5M-25-JA	38	2.38	2.34	2.60	JA	B1F	1.00	-	-	1 1/4	1 3/16	0.90
*P40-5M-25-JA	40	2.51	2.46	2.70	JA	B1F	1.00	-	-	1 1/4	1 3/16	1.00
*P44-5M-25-JA	44	2.76	2.71	2.91	JA	B1F	1.00	-	-	1 1/4	1 3/16	1.18
+P48-5M-25-JA	48	3.01	2.97	3.27	JA	C1F	1.00	-	0.72	1 1/4	1 3/16	1.31
P52-5M-25-JA	52	3.26	3.21	3.43	JA	C1F	1.00	-	0.72	1 1/4	1 3/16	1.51
P56-5M-25-SH	56	3.51	3.47	3.74	SH	C1F	1.31	-	0.47	1 11/16	1 5/8	1.70
P60-5M-25-SH	60	3.76	3.72	4.02	SH	C1F	1.31	-	0.47	1 11/16	1 5/8	1.96
P64-5M-25-SH	64	4.01	3.97	4.25	SH	C1F	1.31	-	0.47	1 11/16	1 5/8	2.24
P68-5M-25-SDS	68	4.26	4.22	4.45	SDS	C1F	1.31	-	0.53	2	1 15/16	2.30
P72-5M-25-SDS	72	4.51	4.47	4.69	SDS	C1F	1.31	-	0.53	2	1 15/16	2.59
P80-5M-25-SDS	80	5.01	4.97	-	SDS	C1	1.31	-	0.53	2	1 15/16	3.21
P90-5M-25-SDS	90	5.64	5.59	-	SDS	C1	1.31	-	0.53	2	1 15/16	3.77
P112-5M-25-SDS	112	7.02	6.97	-	SDS	C1	1.31	-	0.53	2	1 15/16	5.59

* = Can only be mounted from one direction

+ = Includes cap screws to be used in place of the ones that come with the bushing

PB pulleys have no keyway and no set screw. Rebore available upon request.

8M HTD Timing Pulley Dimensions

For 8M HTD Timing Belts.

See page 123

Order QD bushings separately

Stock Bushings Located

on Pages 84-85.

The Timing Pulleys listed below are all stock sizes.

The figure following the type sketch letter in the "Type" column indicates the construction:

(1-Solid, 2-Web, 3-Spoked), and the letter F indicates the sprocket has flanges.

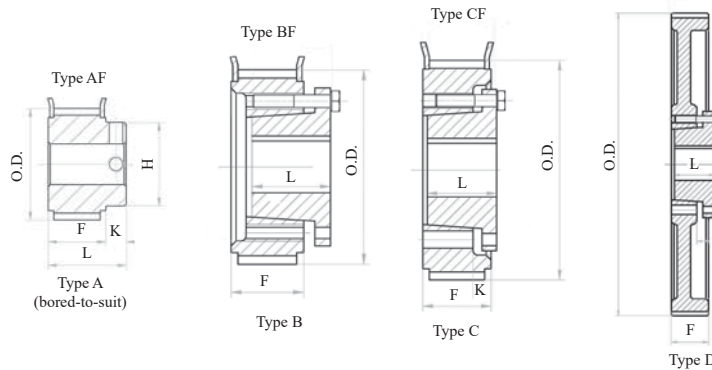

For belts 20MM wide * 8MM Pitch * Face Width (F) = 1 7/64"												
Part No.	No. of Teeth	Pitch Dia.	O.D.		Bore	Type	Dimensions			Max. Bore No Keyway	Max. Bore Std. Keyway	Wt.
			Pulley	Flange			L	H	K			
P22-8M-20-PB	22	2.21	2.15	2.46	MPB	A1F	1.85	1.61	0.75	1 5/16	1 1/8	1.11
*P24-8M-20-JA	24	2.41	2.35	2.70	JA	B1F	1.00	-	-	1 1/4	1 3/16	0.85
*P26-8M-20-JA	26	2.61	2.55	2.95	JA	B1F	1.00	-	-	1 1/4	1 3/16	1.01
P28-8M-20-H	28	2.81	2.76	3.15	H	B1F	1.34	-	-	-	1 1/2	1.10
P30-8M-20-H	30	3.01	2.96	3.35	H	B1F	1.34	-	-	-	1 1/2	1.29
P32-8M-20-H	32	3.21	3.15	3.54	H	B1F	1.34	-	-	-	1 1/2	1.46
P34-8M-20-SH	34	3.41	3.35	3.86	SH	B1F	1.31	-	-	1 11/16	1 5/8	1.56
P36-8M-20-SH	36	3.61	3.56	3.94	SH	C1F	1.31	-	0.29	1 11/16	1 5/8	1.76
P38-8M-20-SH	38	3.81	3.76	4.09	SH	C1F	1.31	-	0.29	1 11/16	1 5/8	1.97
P40-8M-20-SH	40	4.01	3.96	4.33	SH	C1F	1.31	-	0.29	1 11/16	1 5/8	2.19
P44-8M-20-SDS	44	4.41	4.36	4.69	SDS	C1F	1.31	-	0.35	2	1 15/16	2.48
P48-8M-20-SDS	48	4.81	4.76	5.16	SDS	C1F	1.31	-	0.35	2	1 15/16	2.97
P56-8M-20-SDS	56	5.61	5.56	5.98	SDS	C1F	1.31	-	0.35	2	1 15/16	4.04
P64-8M-20-SDS	64	6.42	6.36	6.89	SDS	C1F	1.31	-	0.35	2	1 15/16	5.27
P72-8M-20-SDS	72	7.22	7.17	7.56	SDS	C1F	1.31	-	0.35	2	1 15/16	5.70
P80-8M-20-SDS	80	8.02	7.97	8.39	SDS	C1F	1.31	-	0.35	2	1 15/16	7.19
P90-8M-20-SDS	90	9.02	8.97	-	SDS	D2	1.31	-	0.35	2	1 15/16	8.91

* = Can only be mounted from one direction

PB pulleys have no keyway and no set screw. Rebore available upon request.

8M HTD Timing Pulley Dimensions

For 8M HTD Timing Belts.
See page 123
Order QD bushings separately
Stock Bushings Located
on Pages 84-85.

The Timing Pulleys listed below are all stock sizes.
The figure following the type sketch letter in the “Type” column indicates the construction:
(1-Solid, 2-Web, 3-Spoked), and the letter F indicates the sprocket has flanges.

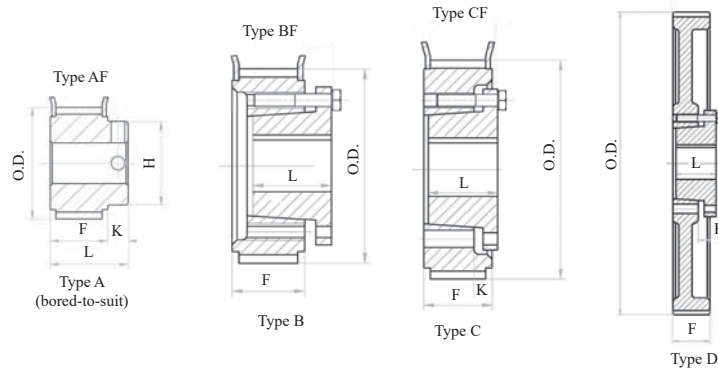

For belts 30MM wide * 8MM Pitch * Face Width (F) = 1 1/2"												
Part No.	No. of Teeth	Pitch Dia.	O.D.		Bore	Type	Dimensions			Max. Bore No Keyway	Max. Bore Std. Keyway	Wt.
			Pulley	Flange			L	H	K			
P22-8M-30-PB	22	2.21	2.15	2.46	MPB	A1F	2.25	1.61	0.75	1 5/16	1 1/8	1.35
P24-8M-30-PB	24	2.41	2.35	2.70	MPB	A1F	2.25	1.81	0.75	1 1/2	1 1/4	1.08
P26-8M-30-PB	26	2.61	2.55	2.95	MPB	A1F	2.25	2.00	0.75	1 3/4	1 3/8	1.29
P28-8M-30-H	28	2.81	2.76	3.15	H	B1F	1.34	-	-	-	1 1/2	1.41
P30-8M-30-H	30	3.01	2.96	3.35	H	B1F	1.34	-	-	-	1 1/2	1.65
P32-8M-30-H	32	3.21	3.15	3.54	H	B1F	1.34	-	-	-	1 1/2	1.82
+P34-8M-30-SH	34	3.41	3.35	3.86	SH	C1F	1.31	-	0.69	1 11/16	1 5/8	1.95
+P36-8M-30-SH	36	3.61	3.56	3.94	SH	C1F	1.31	-	0.69	1 11/16	1 5/8	2.18
+P38-8M-30-SH	38	3.81	3.76	4.09	SH	C1F	1.31	-	0.69	1 11/16	1 5/8	2.42
+P40-8M-30-SH	40	4.01	3.96	4.33	SH	C1F	1.31	-	0.69	1 11/16	1 5/8	2.67
+P44-8M-30-SDS	44	4.41	4.36	4.69	SDS	C1F	1.31	-	0.74	2	1 15/16	3.01
P48-8M-30-SDS	48	4.81	4.76	5.16	SDS	C1F	1.31	-	0.74	2	1 15/16	3.55
P56-8M-30-SDS	56	5.61	5.56	5.98	SDS	C1F	1.31	-	0.74	2	1 15/16	4.74
P64-8M-30-SK	64	6.42	6.36	6.89	SK	C1F	1.94	-	0.24	2 5/8	2 1/2	6.85
P72-8M-30-SK	72	7.22	7.17	7.56	SK	C1F	1.94	-	0.24	2 5/8	2 1/2	8.83
P80-8M-30-SK	80	8.02	7.97	8.39	SK	C2F	1.94	-	0.24	2 5/8	2 1/2	9.58
P90-8M-30-SK	90	9.02	8.97	-	SK	D2	1.94	-	0.24	2 5/8	2 1/2	11.66
P112-8M-30-SK	112	11.23	11.17	-	SK	D2	1.94	-	0.24	2 5/8	2 1/2	16.06

+ = Includes cap screws to be used in place of the ones that come with the bushing

PB pulleys have no keyway and no set screw. Rebore available upon request.

8M HTD Timing Pulley Dimensions

For 8M HTD Timing Belts.

See page 123

Order QD bushings separately
Stock Bushings Located
on Pages 84-85.

The Timing Pulleys listed below are all stock sizes.

The figure following the type sketch letter in the "Type" column indicates the construction:

(1-Solid, 2-Web, 3-Spoked), and the letter F indicates the sprocket has flanges.

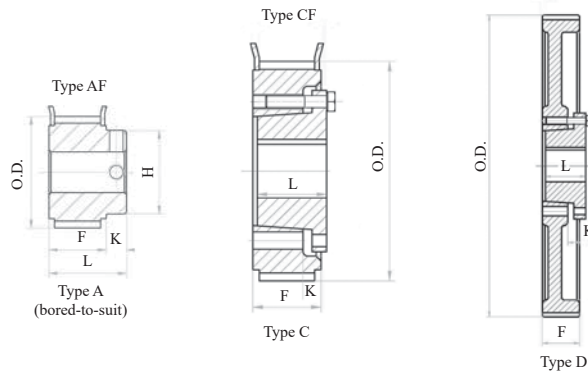

For belts 50MM wide * 8MM Pitch * Face Width (F) = 2 3/8"

Part No.	No. of Teeth	Pitch Dia.	O.D.		Bore	Type	Dimensions			Max. Bore No Keyway	Max. Bore Std. Keyway	Wt.
			Pulley	Flange			L	H	K			
P28-8M-50-PB	28	2.81	2.76	3.15	MPB	A1F	3.11	1.97	0.75	1 11/16	1 3/8	3.16
P30-8M-50-PB	30	3.01	2.96	3.35	MPB	A1F	3.11	2.17	0.75	1 7/8	1 1/2	3.53
P32-8M-50-PB	32	3.21	3.15	3.54	MPB	A1F	3.11	2.36	0.75	2 1/16	1 5/8	3.92
*P34-8M-50-SH	34	3.41	3.35	3.86	SH	C1F	1.31	-	0.50	1 11/16	1 5/8	2.86
*P36-8M-50-SH	36	3.61	3.56	3.94	SH	C1F	1.31	-	0.50	1 11/16	1 5/8	3.53
+P38-8M-50-SH	38	3.81	3.76	4.09	SH	C1F	1.31	-	0.50	1 11/16	1 5/8	3.26
+P40-8M-50-SH	40	4.01	3.96	4.33	SH	C1F	1.31	-	0.50	1 11/16	1 5/8	3.55
P44-8M-50-SD	44	4.41	4.36	4.69	SD	C1F	1.81	-	0.56	2	1 15/16	4.54
P48-8M-50-SD	48	4.81	4.76	5.16	SD	C1F	1.81	-	0.56	2	1 15/16	5.36
P56-8M-50-SK	56	5.61	5.56	5.98	SK	C1F	1.94	-	0.56	2 5/8	2 1/2	6.72
P64-8M-50-SK	64	6.42	6.36	6.89	SK	C1F	1.94	-	0.56	2 5/8	2 1/2	8.74
P72-8M-50-SK	72	7.22	7.17	7.56	SK	C1F	1.94	-	0.56	2 5/8	2 1/2	10.98
P80-8M-50-SF	80	8.02	7.97	8.39	SF	C1F	2.06	-	0.56	2 15/16	2 7/8	13.72
P90-8M-50-SF	90	9.02	8.97	-	SF	D1	2.06	-	0.56	2 15/16	2 7/8	15.64
P112-8M-50-SF	112	11.23	11.17	-	SF	D2	2.06	-	0.75	2 15/16	2 7/8	21.64

* = Can only be mounted from one direction

+ = Includes cap screws to be used in place of the ones that come with the bushing

PB pulleys have no keyway and no set screw. Rebore available upon request.

8M HTD Timing Pulley Dimensions

For 8M HTD Timing Belts.
See page 123
Order QD bushings separately
Stock Bushings Located
on Pages 84-85.

The Timing Pulleys listed below are all stock sizes.
The figure following the type sketch letter in the “Type” column indicates the construction:
(1-Solid, 2-Web, 3-Spoked), and the letter F indicates the sprocket has flanges.

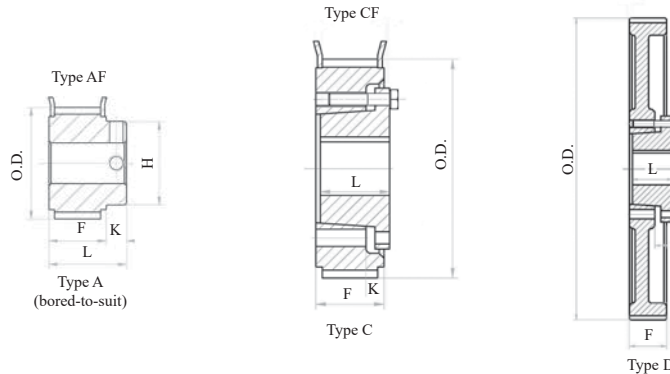

For belts 85MM wide * 8MM Pitch * Face Width (F) = 3 3/4"												
Part No.	No. of Teeth	Pitch Dia.	O.D.		Bore	Type	Dimensions			Max. Bore No Keyway	Max. Bore Std. Keyway	Wt.
			Pulley	Flange			L	H	K			
P34-8M-85-PB	34	3.41	3.35	3.86	MPB	A1F	4.49	2.76	0.75	2 1/2	2	6.56
+*P36-8M-85-SH	36	3.61	3.56	3.94	SH	C1F	1.31	-	1.47	1 11/16	1 5/8	4.68
+P38-8M-85-SH	38	3.81	3.76	4.09	SH	C1F	1.31	-	1.47	1 11/16	1 5/8	5.09
+P40-8M-85-SD	40	4.01	3.96	4.33	SD	C1F	1.81	-	1.24	2	1 15/16	5.51
+P44-8M-85-SD	44	4.41	4.36	4.69	SD	C1F	1.81	-	1.24	2	1 15/16	6.48
P48-8M-85-SD	48	4.81	4.76	5.16	SD	C1F	1.81	-	1.24	2	1 15/16	7.51
P56-8M-85-SK	56	5.61	5.56	5.98	SK	C1F	1.94	-	1.24	2 5/8	2 1/2	9.29
P64-8M-85-SK	64	6.42	6.36	6.89	SK	C1F	1.94	-	1.24	2 5/8	2 1/2	11.44
P72-8M-85-SF	72	7.22	7.17	7.56	SF	C1F	2.06	-	1.24	2 15/16	2 7/8	14.16
P80-8M-85-SF	80	8.02	7.97	8.39	SF	C1F	2.06	-	1.24	2 15/16	2 7/8	18.15
P90-8M-85-SF	90	9.02	8.97	-	SF	D1	2.06	-	1.24	2 15/16	2 7/8	23.35
P112-8M-85-SF	112	11.23	11.17	-	SF	D2	2.06	-	1.24	2 15/16	2 7/8	36.95

* = Can only be mounted from one direction

+ = Includes cap screws to be used in place of the ones that come with the bushing

PB pulleys have no keyway and no set screw. Rebore available upon request.

For 14M HTD Timing Belts.

See page 124

Order QD bushings separately

Stock Bushings Located

on Pages 84-85.

14M HTD Timing Pulley Dimensions

The Timing Pulleys listed below are all stock sizes.

The figure following the type sketch letter in the "Type" column indicates the construction:

(1-Solid, 2-Web, 3-Spoked), and the letter F indicates the sprocket has flanges.

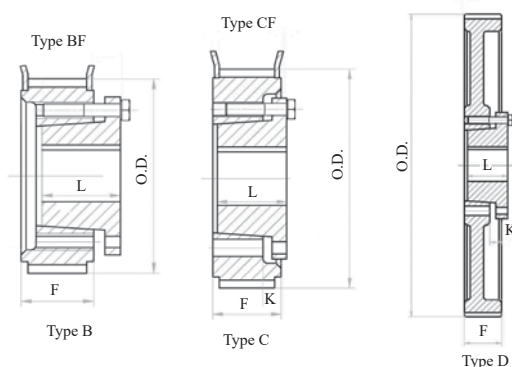

For belts 40MM wide * 14MM Pitch * Face Width (F) = 2 1/8"

Part No.	No. of Teeth	Pitch Dia.	O.D.		Bore	Type	Dimensions			Max. Bore No Keyway	Max. Bore Std. Keyway	Wt.
			Pulley	Flange			L	H	K			
*P28-14M-40-SK	28	4.91	4.81	5.55	SK	B1F	1.94	-	-	2 5/8	2 1/2	4.93
*P29-14M-40-SK	29	5.09	4.98	5.55	SK	B1F	1.94	-	-	2 5/8	2 1/2	5.41
P30-14M-40-SK	30	5.26	5.16	6.10	SK	C1F	1.94	-	0.44	2 5/8	2 1/2	5.73
P32-14M-40-SK	32	5.61	5.51	6.10	SK	C1F	1.94	-	0.44	2 5/8	2 1/2	6.44
P34-14M-40-SK	34	5.97	5.86	6.50	SK	C1F	1.94	-	0.44	2 5/8	2 1/2	7.45
P36-14M-40-SF	36	6.32	6.21	6.81	SF	C1F	2.06	-	0.44	2 15/16	2 7/8	7.83
P38-14M-40-SF	38	6.67	6.56	7.21	SF	C1F	2.06	-	0.44	2 15/16	2 7/8	8.85
P40-14M-40-SF	40	7.02	6.91	7.52	SF	C1F	2.06	-	0.44	2 15/16	2 7/8	10.05
P44-14M-40-E	44	7.72	7.61	8.23	E	C1F	2.75	-	0.50	-	3 1/2	11.89
P48-14M-40-E	48	8.42	8.31	8.90	E	C1F	2.75	-	0.50	-	3 1/2	15.24
P52-14M-40-E	52	9.12	9.01	9.61	E	C1F	2.75	-	0.25	-	3 1/2	18.13
P56-14M-40-E	56	9.83	9.72	10.39	E	C1F	2.75	-	0.25	-	3 1/2	21.22
P60-14M-40-E	60	10.53	10.42	11.14	E	C1F	2.75	-	0.50	-	3 1/2	24.60
P64-14M-40-E	64	11.23	11.12	11.73	E	C1F	2.75	-	0.50	-	3 1/2	22.36
P68-14M-40-E	68	11.93	11.82	12.48	E	C2F	2.75	-	0.50	-	3 1/2	23.90
P72-14M-40-E	72	12.63	12.52	13.19	E	C2F	2.75	-	0.31	-	3 1/2	24.41
P80-14M-40-E	80	14.04	13.93	14.65	E	C3F	2.75	-	0.50	-	3 1/2	27.01
P90-14M-40-E	90	15.82	15.68	-	E	D3	2.75	-	0.25	-	3 1/2	29.39
P112-14M-40-E	112	19.65	19.54	-	E	D3	2.75	-	0.25	-	3 1/2	41.04

* = Can only be mounted from one direction

14M HTD Timing Pulley Dimensions

For 14M HTD Timing Belts.
See page 124
Order QD bushings separately
Stock Bushings Located
on Pages 84-85.

The Timing Pulleys listed below are all stock sizes.
The figure following the type sketch letter in the “Type” column indicates the construction:
(1-Solid, 2-Web, 3-Spoked), and the letter F indicates the sprocket has flanges.

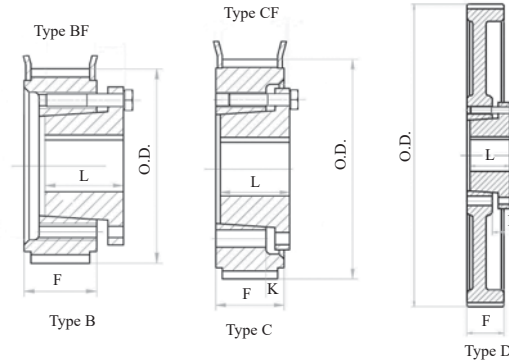

For belts 55MM wide * 14MM Pitch * Face Width (F) = 2 3/4"												
Part No.	No. of Teeth	Pitch Dia.	O.D.		Bore	Type	Dimensions			Max. Bore No Keyway	Max. Bore Std. Keyway	Wt.
			Pulley	Flange			L	H	K			
*P28-14M-55-SK	28	4.91	4.81	5.55	SK	B1F	1.94	-	-	2 5/8	2 1/2	6.14
*P29-14M-55-SK	29	5.09	4.98	5.55	SK	B1F	1.94	-	-	2 5/8	2 1/2	6.75
+P30-14M-55-SK	30	5.26	5.16	6.10	SK	C1F	1.94	-	0.75	2 5/8	2 1/2	7.07
+P32-14M-55-SK	32	5.61	5.51	6.10	SK	C1F	1.94	-	0.75	2 5/8	2 1/2	7.81
+P34-14M-55-SK	34	5.97	5.86	6.50	SK	C1F	1.94	-	0.75	2 5/8	2 1/2	9.04
+P36-14M-55-SF	36	6.32	6.21	6.81	SF	C1F	2.06	-	0.75	2 15/16	2 7/8	9.36
P38-14M-55-SF	38	6.67	6.56	7.21	SF	C1F	2.06	-	0.75	2 15/16	2 7/8	10.55
P40-14M-55-SF	40	7.02	6.91	7.52	SF	C1F	2.06	-	0.75	2 15/16	2 7/8	12.01
P44-14M-55-E	44	7.72	7.61	8.23	E	C1F	2.75	-	0.56	-	3 1/2	13.80
P48-14M-55-E	48	8.42	8.31	8.90	E	C1F	2.75	-	0.56	-	3 1/2	17.71
P52-14M-55-E	52	9.12	9.01	9.61	E	C1F	2.75	-	0.56	-	3 1/2	20.86
P56-14M-55-E	56	9.83	9.72	10.39	E	C1F	2.75	-	0.56	-	3 1/2	24.19
P60-14M-55-E	60	10.53	10.42	11.14	E	C1F	2.75	-	0.56	-	3 1/2	27.91
P64-14M-55-F	64	11.23	11.12	11.73	F	C1F	3.75	-	0.13	4	3 15/16	37.14
P68-14M-55-F	68	11.93	11.82	12.48	F	C1F	3.75	-	0.13	4	3 15/16	33.38
P72-14M-55-F	72	12.63	12.52	13.19	F	C1F	3.75	-	0.13	4	3 15/16	33.24
P80-14M-55-F	80	14.04	13.93	14.65	F	C1F	3.75	-	0.13	4	3 15/16	36.80
P90-14M-55-F	90	15.82	15.68	-	F	D2	3.75	-	0.13	4	3 15/16	39.60
P112-14M-55-F	112	19.65	19.54	-	F	D3	3.75	-	0.13	4	3 15/16	52.34

* = Can only be mounted from one direction

+ = Includes cap screws to be used in place of the ones that come with the bushing

14M HTD Timing Pulley Dimensions

For 14M HTD Timing Belts.

See page 124

Order QD bushings separately
Stock Bushings Located
on Pages 84-85.

The Timing Pulleys listed below are all stock sizes.

The figure following the type sketch letter in the “Type” column indicates the construction: (1-Solid, 2-Web, 3-Spoked), and the letter F indicates the sprocket has flanges.

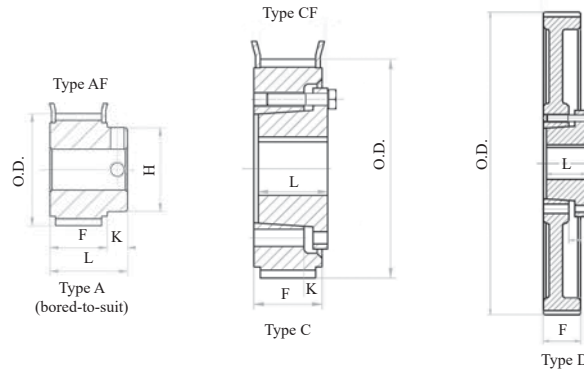

For belts 85MM wide * 14MM Pitch * Face Width (F) = 4"												
Part No.	No. of Teeth	Pitch Dia.	O.D.		Bore	Type	Dimensions			Max. Bore No Keyway	Max. Bore Std. Keyway	Wt.
			Pulley	Flange			L	H	K			
P28-14M-85-PB	28	4.91	4.81	5.55	MPB	A1F	4.00	3.69	1.00	3 7/16	2 3/4	8.94
P29-14M-85-PB	29	5.09	4.98	5.55	MPB	A1F	4.00	3.69	1.00	3 7/16	2 3/4	9.58
+P30-14M-85-SK	30	5.26	5.16	6.10	SK	C1F	1.94	-	1.37	2 5/8	2 1/2	10.17
+P32-14M-85-SK	32	5.61	5.51	6.10	SK	C1F	1.94	-	1.37	2 5/8	2 1/2	11.02
+P34-14M-85-SK	34	5.97	5.86	6.50	SK	C1F	1.94	-	1.37	2 5/8	2 1/2	12.72
+P36-14M-85-SF	36	6.32	6.21	6.81	SF	C1F	2.06	-	1.50	2 15/16	2 7/8	12.98
P38-14M-85-SF	38	6.67	6.56	7.21	SF	C1F	2.06	-	1.37	2 15/16	2 7/8	14.53
P40-14M-85-SF	40	7.02	6.91	7.52	SF	C1F	2.06	-	1.37	2 15/16	2 7/8	16.56
+P44-14M-85-E	44	7.72	7.61	8.23	E	C1F	2.75	-	1.19	-	3 1/2	18.31
P48-14M-85-E	48	8.42	8.31	8.90	E	C1F	2.75	-	1.19	-	3 1/2	22.67
P52-14M-85-E	52	9.12	9.01	9.61	E	C1F	2.75	-	1.19	-	3 1/2	26.33
P56-14M-85-F	56	9.83	9.72	10.39	F	C1F	3.75	-	0.75	4	3 15/16	33.44
P60-14M-85-F	60	10.53	10.42	11.14	F	C1F	3.75	-	0.75	4	3 15/16	38.80
P64-14M-85-F	64	11.23	11.12	11.73	F	C1F	3.75	-	0.75	4	3 15/16	44.12
P68-14M-85-F	68	11.93	11.82	12.48	F	C1F	3.75	-	0.75	4	3 15/16	41.42
P72-14M-85-F	72	12.63	12.52	13.19	F	C1F	3.75	-	0.75	4	3 15/16	43.74
P80-14M-85-F	80	14.04	13.93	14.65	F	C1F	3.75	-	0.75	4	3 15/16	46.21
P90-14M-85-F	90	15.82	15.68	-	F	D3	3.75	-	0.75	4	3 15/16	50.22
P112-14M-85-F	112	19.65	19.54	-	F	D3	3.75	-	0.75	4	3 15/16	65.42

+ = Includes cap screws to be used in place of the ones that come with the bushing

PB pulleys have no keyway and no set screw. Rebore available upon request.

14M HTD Timing Pulley Dimensions

For 14M HTD Timing Belts.
See page 124
Order QD bushings separately
Stock Bushings Located
on Pages 84-85.

The Timing Pulleys listed below are all stock sizes.
The figure following the type sketch letter in the "Type" column indicates the construction:
(1-Solid, 2-Web, 3-Spoked), and the letter F indicates the sprocket has flanges.

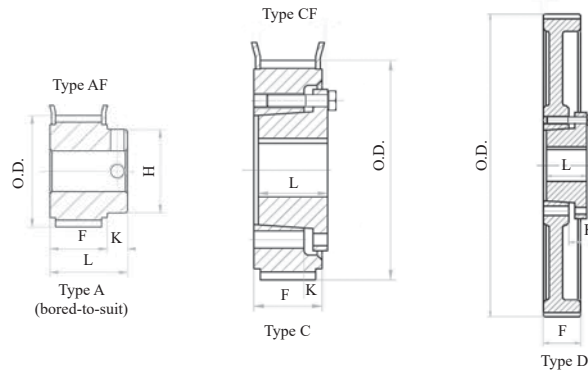

For belts 115MM wide * 14MM Pitch * Face Width (F) = 5 1/4"												
Part No.	No. of Teeth	Pitch Dia.	O.D.		Bore	Type	Dimensions			Max. Bore No Keyway	Max. Bore Std. Keyway	Wt.
			Pulley	Flange			L	H	K			
P28-14M-115-PB	28	4.91	4.81	5.55	MPB	A1F	5.00	3.69	1.25	3 7/16	2 3/4	11.10
P29-14M-115-PB	29	5.09	4.98	5.55	MPB	A1F	5.00	3.69	1.25	3 7/16	2 3/4	12.24
+P30-14M-115-SK	30	5.26	5.16	6.10	SK	C1F	1.94	-	2.00	2 5/8	2 1/2	12.94
+P32-14M-115-SK	32	5.61	5.51	6.10	SK	C1F	1.94	-	2.00	2 5/8	2 1/2	13.87
+P34-14M-115-SK	34	5.97	5.86	6.50	SK	C1F	1.94	-	2.00	2 5/8	2 1/2	16.01
+P36-14M-115-SF	36	6.32	6.21	6.81	SF	C1F	2.06	-	2.00	2 15/16	2 7/8	16.16
P38-14M-115-SF	38	6.67	6.56	7.21	SF	C1F	2.06	-	2.00	2 15/16	2 7/8	18.06
P40-14M-115-SF	40	7.02	6.91	7.52	SF	C1F	2.06	-	2.00	2 15/16	2 7/8	20.63
+P44-14M-115-E	44	7.72	7.61	8.23	E	C1F	2.75	-	2.00	-	3 1/2	22.28
P48-14M-115-E	48	8.42	8.31	8.90	E	C1F	2.75	-	1.94	-	3 1/2	27.62
P52-14M-115-F	52	9.12	9.01	9.61	F	C1F	3.75	-	1.38	4	3 15/16	34.08
P56-14M-115-F	56	9.83	9.72	10.39	F	C1F	3.75	-	1.38	4	3 15/16	39.38
P60-14M-115-F	60	10.53	10.42	11.14	F	C1F	3.75	-	1.38	4	3 15/16	45.41
P64-14M-115-J	64	11.23	11.12	11.73	J	C1F	4.63	-	1.00	-	4 1/2	53.84
P68-14M-115-J	68	11.93	11.82	12.48	J	C1F	4.63	-	1.00	-	4 1/2	60.87
P72-14M-115-J	72	12.63	12.52	13.19	J	C1F	4.63	-	1.00	-	4 1/2	68.57
P80-14M-115-J	80	14.04	13.93	14.65	J	C2F	4.63	-	1.00	-	4 1/2	65.99
P90-14M-115-J	90	15.82	15.68	-	J	D2	4.63	-	1.00	-	4 1/2	74.70
P112-14M-115-J	112	19.65	19.54	-	J	D3	4.63	-	1.00	-	4 1/2	86.79

+ = Includes cap screws to be used in place of the ones that come with the bushing

PB pulleys have no keyway and no set screw. Rebore available upon request.

1/SPZ60-1008

Number of Grooves	Belt Size	Pitch Dia.	Bushing
1	SPZ	60MM	1008

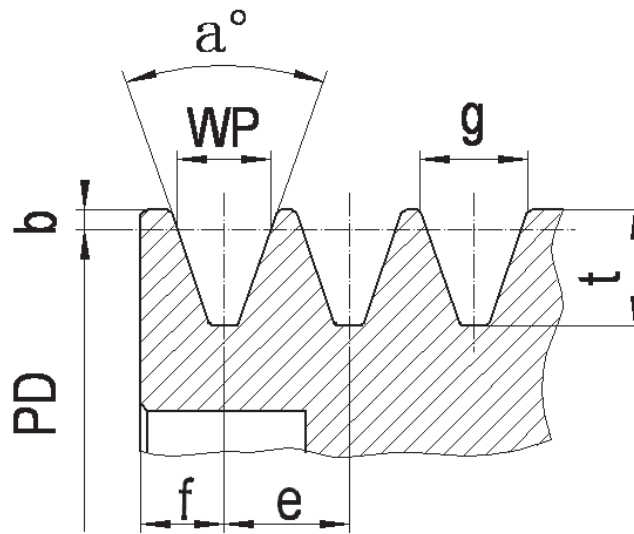

(mm)

Groove Profile	WP	b	t	e	f	PD	Angle a°	g
SPZ	8.5	2.0	11.0	12	8.0	≤ 80	34	9.72
						> 80	38	9.88
SPA	11.0	2.8	13.8	15	10.0	≤ 118	34	12.68
						> 118	38	12.89
SPB	14.0	3.5	17.5	19	12.5	≤ 190	34	16.14
						> 190	38	16.41
SPC	19.0	4.8	23.8	25.5	17.0	≤ 315	34	21.94
						> 315	38	22.31

Cast Iron Sheaves - **Heavy Duty**
Bushed, **One and Two Groove**
SPZ TB Sheaves

Order part number size
Example: 1/SPZ60-1008

For SPZ V-Belts

Order TB bushings separately (Pages 87-88)

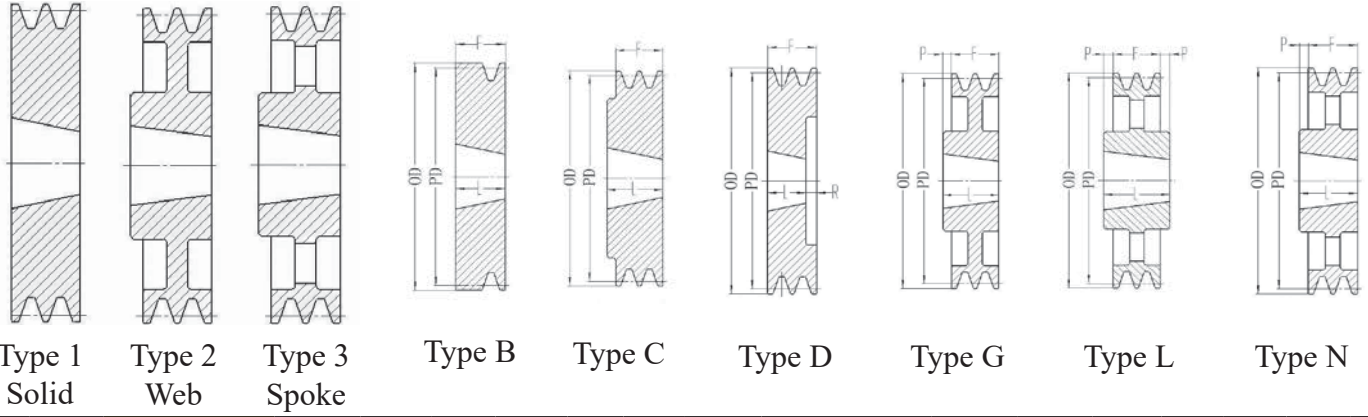

O.D. (mm)	P.D. (mm)	Part No.	Bush	Type	Dimensions (mm)				Wt.	Part No.	Bush	Type	Dimensions (mm)				Wt.
					F	L	R	P					F	L	R	P	
64	60	1/SPZ60-1008	1008	B-1	22	22	-	-	0.68	2/SPZ60-1108	1108	D-1	49	22	27	-	1.48
67	63	1/SPZ63-1108	1108	C-1	16	22	-	-	0.62	2/SPZ63-1108	1108	D-1	28	22	6	-	0.68
71	67	1/SPZ67-1108	1108	C-1	16	22	-	-	0.71	2/SPZ67-1108	1108	D-1	28	22	6	-	0.84
75	71	1/SPZ71-1108	1108	C-1	16	22	-	-	0.79	2/SPZ71-1108	1108	D-1	28	22	6	-	0.97
79	75	1/SPZ75-1108	1108	C-1	16	22	-	-	0.90	2/SPZ75-1210	1210	D-1	28	25	3	-	0.93
84	80	1/SPZ80-1210	1210	C-1	16	25	-	-	1.12	2/SPZ80-1210	1210	D-1	28	25	3	-	1.17
89	85	1/SPZ85-1210	1210	C-1	16	25	-	-	1.28	2/SPZ85-1610	1610	D-1	28	25	3	-	1.17
94	90	1/SPZ90-1210	1210	C-1	16	25	-	-	1.46	2/SPZ90-1610	1610	D-1	28	25	3	-	1.43
99	95	1/SPZ95-1210	1210	C-1	16	25	-	-	1.63	2/SPZ95-1610	1610	D-1	28	25	3	-	1.68
104	100	1/SPZ100-1210	1210	C-1	16	25	-	-	1.81	2/SPZ100-1610	1610	D-1	28	25	3	-	2.01
110	106	1/SPZ106-1610	1610	C-1	16	25	-	-	2.09	2/SPZ106-1610	1610	D-1	28	25	3	-	2.51
116	112	1/SPZ112-1610	1610	C-1	16	25	-	-	2.18	2/SPZ112-1610	1610	D-1	28	25	3	-	2.80
122	118	1/SPZ118-1610	1610	C-1	16	25	-	-	2.47	2/SPZ118-1610	1610	D-1	28	25	3	-	3.42
129	125	1/SPZ125-1610	1610	C-1	16	25	-	-	2.82	2/SPZ125-1610	1610	D-1	28	25	3	-	2.82
136	132	1/SPZ132-1610	1610	C-1	16	25	-	-	3.53	2/SPZ132-1610	1610	D-1	28	25	3	-	4.30
144	140	1/SPZ140-1610	1610	G-2	16	25	-	9	3.02	2/SPZ140-1610	1610	D-1	28	25	3	-	4.96
154	150	1/SPZ150-1610	1610	G-2	16	25	-	9	3.42	2/SPZ150-2012	2012	C-1	28	32	-	-	6.13
164	160	1/SPZ160-1610	1610	G-2	16	25	-	9	3.75	2/SPZ160-2012	2012	G-2	28	32	-	4	5.62
174	170	1/SPZ170-1610	1610	G-2	16	25	-	9	4.08	2/SPZ170-2012	2012	G-2	28	32	-	4	6.04
184	180	1/SPZ180-1610	1610	G-2	16	25	-	9	4.45	2/SPZ180-2012	2012	G-2	28	32	-	4	5.95
194	190	1/SPZ190-1610	1610	G-2	16	25	-	9	4.76	2/SPZ190-2012	2012	G-2	28	32	-	4	7.32
204	200	1/SPZ200-2012	2012	G-2	16	32	-	16	6.24	2/SPZ200-2012	2012	G-2	28	32	-	4	7.96
228	224	1/SPZ224-2012	2012	N-3	16	32	-	16	6.83	2/SPZ224-2012	2012	N-3	28	32	-	4	8.77
254	250	1/SPZ250-2012	2012	L-3	16	32	-	8	7.43	2/SPZ250-2012	2012	L-3	28	32	-	2	10.16
284	280	1/SPZ280-2012	2012	L-3	16	32	-	8	8.31								
319	315	1/SPZ315-2012	2012	L-3	16	32	-	8	10.91	2/SPZ315-2012	2012	L-3	28	32	-	2	11.93
359	355	1/SPZ355-2012	2012	L-3	16	32	-	8	11.57	2/SPZ355-2012	2012	L-3	28	32	-	2	16.76
404	400	1/SPZ400-2012	2012	L-3	16	32	-	8	14.11	2/SPZ400-2517	*2517	L-3	28	45	-	8.5	21.83
454	450									2/SPZ450-2517	*2517	L-3	28	45	-	8.5	22.71
504	500									2/SPZ500-2517	*2517	L-3	28	45	-	8.5	28.66

* Caution: Metric sheaves requiring TB bushing 2517 or 3535 MUST use bushings with BSW threads (2517-BSW or 3535-BSW)

SPZ Sheaves

Cast Iron Sheaves - **Heavy Duty**
Bushed, **Three and Four Groove**
SPZ TB Sheaves

Order part number size
Example: 3/SPZ63-1108

For SPZ V-Belts

Order TB bushings separately (Pages 87-88)

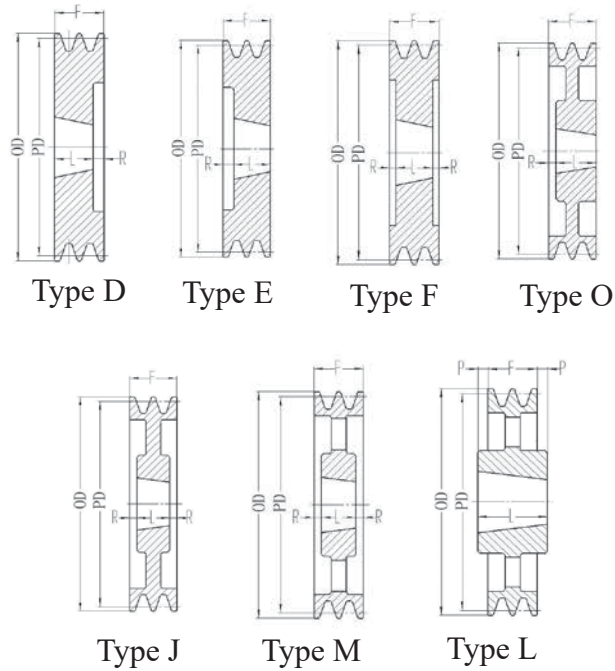
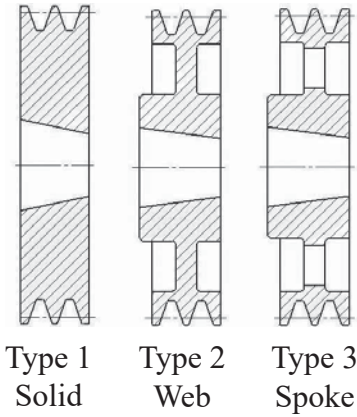

O.D. (mm)	P.D. (mm)	Part No.	Bush	Type	Dimensions (mm)				Wt.	Part No.	Bush	Type	Dimensions (mm)				Wt.
					F	L	R	P					F	L	R	P	
67	63	3/SPZ63-1108	1108	D-1	40	22	18	-	1.01								
71	67	3/SPZ67-1108	1108	D-1	40	22	18	-	1.17								
75	71	3/SPZ71-1108	1108	D-1	40	22	18	-	1.37								
79	75	3/SPZ75-1210	1210	D-1	40	25	15	-	1.28								
84	80	3/SPZ80-1210	1210	D-1	40	25	15	-	1.57	4/SPZ80-1210	1210	D-1	52	25	27	-	1.98
89	85	3/SPZ85-1610	1610	D-1	40	25	15	-	1.59	4/SPZ85-1610	1610	D-1	52	25	27	-	2.07
94	90	3/SPZ90-1610	1610	D-1	40	25	15	-	1.90	4/SPZ90-1610	1610	D-1	52	25	27	-	2.40
99	95	3/SPZ95-1610	1610	D-1	40	25	15	-	2.23	4/SPZ95-1610	1610	D-1	52	25	27	-	2.76
104	100	3/SPZ100-1610	1610	D-1	40	25	15	-	2.56	4/SPZ100-1610	1610	D-1	52	25	27	-	3.02
110	106	3/SPZ106-1610	1610	D-1	40	25	15	-	2.98	4/SPZ106-1610	1610	D-1	52	25	27	-	3.40
116	112	3/SPZ112-2012	2012	D-1	40	32	8	-	3.20	4/SPZ112-2012	2012	D-1	52	32	20	-	3.62
122	118	3/SPZ118-2012	2012	D-1	40	32	8	-	3.64	4/SPZ118-2012	2012	D-1	52	32	20	-	4.21
129	125	3/SPZ125-2012	2012	E-1	40	32	8	-	4.37	4/SPZ125-2012	2012	E-1	52	32	20	-	4.92
136	132	3/SPZ132-2012	2012	E-1	40	32	8	-	5.09	4/SPZ132-2012	2012	E-1	52	32	20	-	5.78
144	140	3/SPZ140-2012	2012	E-1	40	32	8	-	3.75	4/SPZ140-2012	2012	E-1	52	32	20	-	6.77
154	150	3/SPZ150-2012	2012	E-1	40	32	8	-	7.10	4/SPZ150-2517	*2517	E-1	52	45	7	-	8.33
164	160	3/SPZ160-2012	2012	E-1	40	32	8	-	8.36	4/SPZ160-2517	*2517	E-1	52	45	7	-	10.08
174	170	3/SPZ170-2012	2012	F-1	40	32	4	-	9.74	4/SPZ170-2517	*2517	E-1	52	45	7	-	11.95
184	180	3/SPZ180-2012	2012	O-2	40	32	8	-	7.43	4/SPZ180-2517	*2517	E-1	52	45	7	-	13.85
194	190	3/SPZ190-2012	2012	J-2	40	32	4	-	8.47	4/SPZ190-2517	*2517	J-2	52	45	3.5	-	17.26
204	200	3/SPZ200-2012	2012	J-2	40	32	4	-	9.22	4/SPZ200-2517	*2517	J-2	52	45	3.5	-	11.57
228	224	3/SPZ224-2012	2012	J-2	40	32	4	-	10.67	4/SPZ224-2517	*2517	J-2	52	45	3.5	-	13.43
254	250	3/SPZ250-2012	2012	M-3	40	32	4	-	12.32	4/SPZ250-2517	*2517	J-2	52	45	3.5	-	16.95
284	280	3/SPZ280-2517	2517	L-3	40	45	-	2.5	15.98	4/SPZ280-2517	*2517	M-3	52	45	3.5	-	17.28
319	315	3/SPZ315-2517	*2517	L-3	40	45	-	2.5	17.04	4/SPZ315-2517	*2517	M-3	52	45	3.5	-	19.07
359	355	3/SPZ355-2517	*2517	L-3	40	45	-	2.5	19.86	4/SPZ355-2517	*2517	M-3	52	45	3.5	-	25.64
404	400	3/SPZ400-2517	*2517	L-3	40	45	-	2.5	24.91	4/SPZ400-2517	*2517	M-3	52	45	3.5	-	28.66
454	450	3/SPZ450-2517	*2517	L-3	40	45	-	2.5	26.68	4/SPZ450-3020	3020	M-3	52	51	0.5	-	36.82
504	500	3/SPZ500-2517	*2517	L-3	40	45	-	2.5	30.58	4/SPZ500-3020	3020	M-3	52	51	0.5	-	42.99
634	630	3/SPZ630-3020	3020	L-3	40	51	-	5.5	49.16	4/SPZ630-3030	3030	L-3	52	76	-	12	67.02

72 * Caution: Metric sheaves requiring TB bushing 2517 or 3535 MUST use bushings with BSW threads (2517-BSW or 3535-BSW)

Cast Iron Sheaves - **Heavy Duty**
Bushed, **Five and Six Groove**
SPZ TB Sheaves

Order part number size
Example: 5/SPZ85-1610

For SPZ V-Belts

Order TB bushings separately (Pages 87-88)

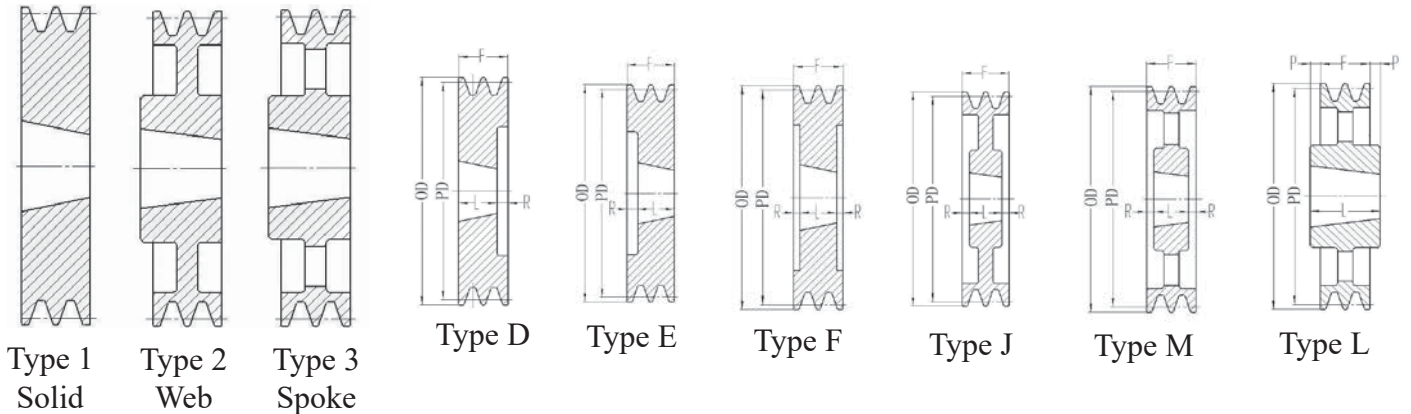

O.D. (mm)	P.D. (mm)	Part No.	Bush	Type	Dimensions (mm)				Wt.	Part No.	Bush	Type	Dimensions (mm)				Wt.
					F	L	R	P					F	L	R	P	
89	85	5/SPZ85-1610	1610	D-1	64	25	39	-	2.54								
94	90	5/SPZ90-1610	1610	D-1	64	25	39	-	2.91								
104	100	5/SPZ100-2012	2012	D-1	64	32	32	-	3.22	6/SPZ100-2012	2012	D-1	76	32	44	-	3.97
110	106	5/SPZ106-2012	2012	D-1	64	32	32	-	3.84	6/SPZ106-2012	2012	D-1	76	32	44	-	4.34
116	112	5/SPZ112-2012	2012	D-1	64	32	32	-	4.63	6/SPZ112-2012	2012	D-1	76	32	44	-	5.51
122	118	5/SPZ118-2012	2012	D-1	64	32	32	-	5.07	6/SPZ118-2517	*2517	D-1	76	45	31	-	4.96
129	125	5/SPZ125-2012	2012	D-1	64	32	32	-	5.73	6/SPZ125-2517	*2517	D-1	76	45	31	-	6.08
136	132	5/SPZ132-2517	*2517	D-1	64	45	19	-	6.17	6/SPZ132-2517	*2517	D-1	76	45	31	-	7.03
144	140	5/SPZ140-2517	*2517	E-1	64	45	19	-	7.76	6/SPZ140-2517	*2517	E-1	76	45	31	-	8.33
154	150	5/SPZ150-2517	*2517	E-1	76	45	31	-	9.26	6/SPZ150-2517	*2517	E-1	76	45	31	-	10.14
164	160	5/SPZ160-2517	*2517	E-1	64	45	19	-	10.87	6/SPZ160-2517	*2517	E-1	76	45	31	-	12.13
174	170	5/SPZ170-2517	*2517	E-1	64	45	19	-	12.94	6/SPZ170-2517	*2517	E-1	76	45	31	-	14.09
184	180	5/SPZ180-2517	*2517	E-1	64	45	19	-	15.15	6/SPZ180-2517	*2517	F-1	76	45	15.5	-	16.40
194	190	5/SPZ190-2517	*2517	J-2	64	45	9.5	-	16.76	6/SPZ190-2517	*2517	J-2	76	45	15.5	-	19.18
204	200	5/SPZ200-2517	*2517	J-2	64	45	9.5	-	13.87	6/SPZ200-2517	*2517	J-2	76	45	15.5	-	20.64
228	224	5/SPZ224-2517	*2517	J-2	64	45	9.5	-	19.36	6/SPZ224-2517	*2517	J-2	76	45	15.5	-	21.30
254	250	5/SPZ250-2517	*2517	J-2	64	45	9.5	-	20.00	6/SPZ250-2517	*2517	J-2	76	45	15.5	-	25.79
284	280	5/SPZ280-2517	*2517	M-3	64	45	9.5	-	21.16	6/SPZ280-2517	*2517	M-3	76	45	15.5	-	24.91
319	315	5/SPZ315-2517	*2517	M-3	64	45	9.5	-	23.68	6/SPZ315-2517	*2517	M-3	76	45	15.5	-	26.30
359	355	5/SPZ355-2517	*2517	M-3	64	45	9.5	-	27.40	6/SPZ355-2517	*2517	M-3	76	45	15.5	-	28.57
404	400	5/SPZ400-3020	3020	M-3	64	51	6.5	-	33.95	6/SPZ400-3030	3030	L-3	76	76	-	0	39.02
454	450	5/SPZ450-3020	3020	M-3	64	51	6.5	-	40.34	6/SPZ450-3030	3030	L-3	76	76	-	0	44.09
504	500	5/SPZ500-3030	3030	L-3	64	76	-	6	52.25	6/SPZ500-3030	3030	L-3	76	76	-	0	52.91
634	630	5/SPZ630-3030	3030	L-3	64	76	-	6	68.34	6/SPZ630-3535	3535	L-3	76	89	-	6.5	74.08

* Caution: Metric sheaves requiring TB bushing 2517 or 3535 MUST use bushings with BSW threads (2517-BSW or 3535-BSW)

SPA Sheaves

Cast Iron Sheaves - **Heavy Duty**
Bushed, **One and Two Groove**
SPA TB Sheaves
Order part number size
Example: 1/SPA80-1210
For SPA V-Belts
Order TB bushings separately
(Pages 87-88)

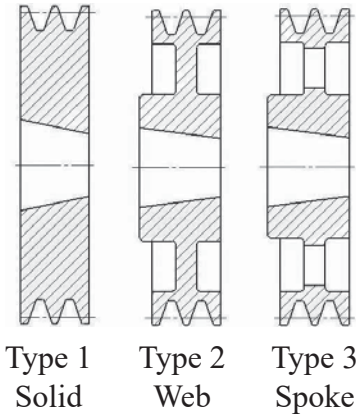

Type 1 Solid
Type 2 Web
Type 3 Spoke

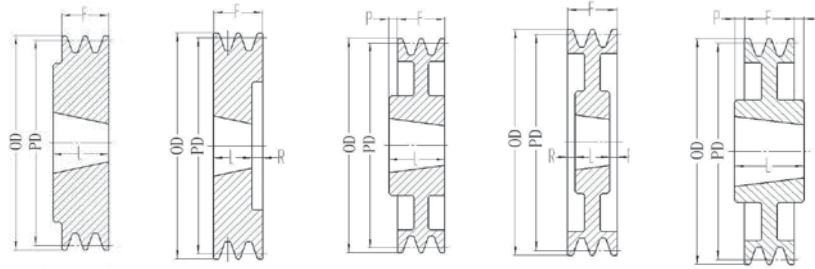

Type C Type D Type G Type J Type K

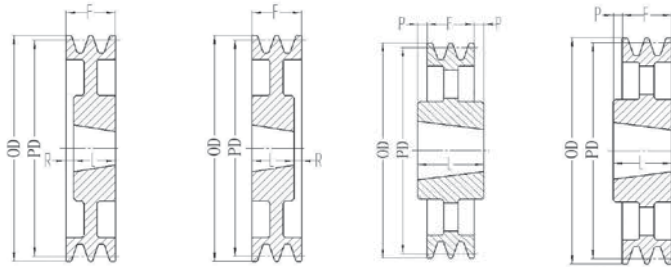

Type O Type P Type L Type N

O.D. (mm)	P.D. (mm)	Part No.	Bush	Type	Dimensions (mm)				Wt.	Part No.	Bush	Type	Dimensions (mm)				Wt.
					F	L	R	P					F	L	R	P	
85.6	80	1/SPA80-1210	1210	C-1	20	25	-	-	1.08	2/SPA80-1210	1210	D-1	35	25	10	-	1.37
90.6	85	1/SPA85-1210	1210	C-1	20	25	-	-	1.28	2/SPA85-1210	1210	D-1	35	25	10	-	1.63
95.6	90	1/SPA90-1210	1210	C-1	20	25	-	5	1.48	2/SPA90-1610	1610	D-1	35	25	10	-	1.59
100.6	95	1/SPA95-1210	1210	C-1	20	25	-	-	1.68	2/SPA95-1610	1610	D-1	35	25	10	-	1.94
105.6	100	1/SPA100-1610	1610	C-1	20	25	-	-	1.72	2/SPA100-1610	1610	D-1	35	25	10	-	2.29
111.6	106	1/SPA106-1610	1610	C-1	20	25	-	-	2.03	2/SPA106-1610	1610	D-1	35	25	10	-	2.65
117.6	112	1/SPA112-1610	1610	C-1	20	25	-	-	2.34	2/SPA112-1610	1610	D-1	35	25	10	-	3.04
123.6	118	1/SPA118-1610	1610	C-1	20	25	-	-	2.71	2/SPA118-1610	1610	D-1	35	25	10	-	3.51
130.6	125	1/SPA125-1610	1610	C-1	20	25	-	-	3.09	2/SPA125-1610	1610	D-1	35	25	10	-	4.12
137.6	132	1/SPA132-1610	1610	C-1	20	25	-	-	3.48	2/SPA132-2012	2012	D-1	35	32	3	-	4.67
145.6	140	1/SPA140-1610	1610	C-1	20	25	-	-	4.03	2/SPA140-2012	2012	D-1	35	32	3	-	5.51
155.6	150	1/SPA150-1610	1610	G-2	20	25	-	5	4.03	2/SPA150-2012	2012	D-1	35	32	3	-	6.59
165.6	160	1/SPA160-1610	1610	G-2	20	25	-	5	5.58	2/SPA160-2012	2012	D-1	35	32	3	-	7.83
175.6	170	1/SPA170-1610	1610	G-2	20	25	-	5	4.70	2/SPA170-2012	2012	P-2	35	32	3	-	7.23
185.6	180	1/SPA180-1610	1610	G-2	20	25	-	5	4.72	2/SPA180-2012	2012	J-2	35	32	1.5	-	7.52
195.6	190	1/SPA190-1610	1610	G-2	20	25	-	5	5.20	2/SPA190-2012	2012	O-2	35	32	3	-	8.20
205.6	200	1/SPA200-2012	2012	G-2	20	32	-	12	6.17	2/SPA200-2517	*2517	K-2	35	45	-	5	10.45
229.6	224	1/SPA224-2012	2012	N-3	20	32	-	12	8.16	2/SPA224-2517	*2517	N-3	35	45	-	10	13.27
255.6	250	1/SPA250-2012	2012	L-3	20	32	-	6	8.80	2/SPA250-2517	*2517	L-3	35	45	-	5	13.45
285.6	280	1/SPA280-2012	2012	N-3	20	32	-	12	10.14	2/SPA280-2517	*2517	N-3	35	45	-	10	14.18
320.6	315	1/SPA315-2012	2012	N-3	20	32	-	12	9.96	2/SPA315-2517	*2517	N-3	35	45	-	10	15.65
360.6	355	1/SPA355-2012	2012	N-3	20	32	-	12	12.28	2/SPA355-2517	*2517	N-3	35	45	-	10	17.86
405.6	400	1/SPA400-2012	2012	N-3	20	32	-	12	14.29	2/SPA400-2517	*2517	N-3	35	45	-	10	21.63
455.6	450	1/SPA450-2012	2012	N-3	20	32	-	12	16.87	2/SPA450-2517	*2517	N-3	35	45	-	10	33.73
505.6	500	1/SPA500-2517	*2517	N-3	20	45	-	25	22.49	2/SPA500-2517	*2517	N-3	35	45	-	10	28.15
635.6	630									2/SPA630-3020	3020	L-3	35	51	-	8	53.57

Cast Iron Sheaves - **Heavy Duty**
Bushed, **Three and Four Groove**
SPA TB Sheaves

Order part number size
Example: 3/SPA80-1210

For SPA V-Belts

Order TB bushings separately (Pages 87-88)

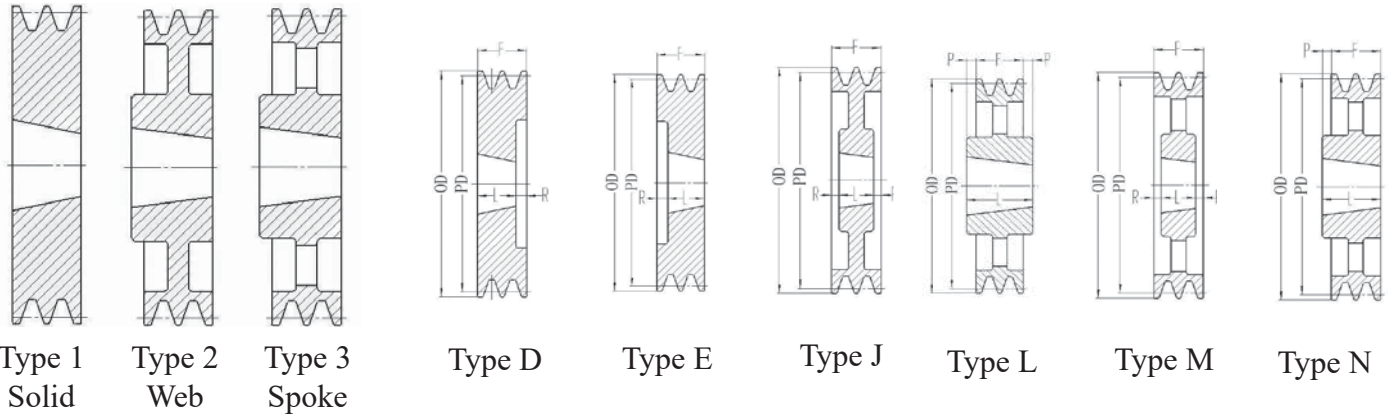

O.D. (mm)	P.D. (mm)	Part No.	Bush	Type	Dimensions (mm)				Wt.	Part No.	Bush	Type	Dimensions (mm)				Wt.
					F	L	R	P					F	L	R	P	
85.6	80	3/SPA80-1210	1210	D-1	50	25	25	-	1.83								
90.6	85	3/SPA85-1210	1210	D-1	50	25	25	-	2.14								
95.6	90	3/SPA90-1610	1610	D-1	50	25	25	-	2.27	4/SPA90-1615	1615	D-1	65	38	27	-	2.93
100.6	95	3/SPA95-1610	1610	D-1	50	25	25	-	2.62	4/SPA95-1615	1615	D-1	65	38	27	-	3.51
105.6	100	3/SPA100-1610	1610	E-1	50	25	25	-	2.87	4/SPA100-1615	1615	E-1	65	38	27	-	3.79
111.6	106	3/SPA106-1610	1610	E-1	50	25	25	-	3.40	4/SPA106-2012	2012	D-1	65	32	33	-	3.75
117.6	112	3/SPA112-2012	2012	D-1	50	32	18	-	3.48	4/SPA112-2012	2012	D-1	65	32	33	-	4.41
123.6	118	3/SPA118-2012	2012	E-1	50	32	18	-	4.06	4/SPA118-2012	2012	E-1	65	32	33	-	4.85
130.6	125	3/SPA125-2012	2012	E-1	50	32	18	-	4.96	4/SPA125-2012	2012	E-1	65	32	33	-	5.91
137.6	132	3/SPA132-2012	2012	E-1	50	32	18	-	5.69	4/SPA132-2517	*2517	E-1	65	45	20	-	6.04
145.6	140	3/SPA140-2517	*2517	D-1	50	45	5	-	8.44	4/SPA140-2517	*2517	E-1	65	45	20	-	7.52
155.6	150	3/SPA150-2517	*2517	D-1	50	45	5	-	8.07	4/SPA150-2517	*2517	E-1	65	45	20	-	9.22
165.6	160	3/SPA160-2517	*2517	D-1	50	45	5	-	9.70	4/SPA160-2517	*2517	E-1	65	45	20	-	11.13
175.6	170	3/SPA170-2517	*2517	D-1	50	45	5	-	11.64	4/SPA170-2517	*2517	E-1	65	45	20	-	13.01
185.6	180	3/SPA180-2517	*2517	D-1	50	45	5	-	13.49	4/SPA180-2517	*2517	E-1	65	45	20	-	14.33
195.6	190	3/SPA190-2517	*2517	D-1	50	45	5	-	15.55	4/SPA190-2517	*2517	E-1	65	45	20	-	17.11
205.6	200	3/SPA200-2517	*2517	J-2	50	45	2.5	-	12.61	4/SPA200-3020	3020	E-1	65	51	14	-	18.30
229.6	224	3/SPA224-2517	*2517	M-3	50	45	2.5	-	13.67	4/SPA224-3020	3020	E-1	65	51	14	-	24.47
255.6	250	3/SPA250-2517	*2517	M-3	50	45	2.5	-	16.09	4/SPA250-3020	3020	J-2	65	51	7	-	21.89
285.6	280	3/SPA280-2517	*2517	M-3	50	45	2.5	-	18.58	4/SPA280-3020	3020	M-3	65	51	7	-	25.13
320.6	315	3/SPA315-3020	3020	L-3	50	51	-	0.5	22.93	4/SPA315-3020	3020	M-3	65	51	7	-	27.56
360.6	355	3/SPA355-3020	3020	L-3	50	51	-	0.5	24.16	4/SPA355-3020	3020	M-3	65	51	7	-	27.54
405.6	400	3/SPA400-3020	3020	N-3	50	51	-	1	28.53	4/SPA400-3020	3020	M-3	65	51	7	-	38.14
455.6	450	3/SPA450-3020	3020	N-3	50	51	-	1	32.63	4/SPA450-3020	3020	M-3	65	51	7	-	38.36
505.6	500	3/SPA500-3020	3020	N-3	50	51	-	1	36.16	4/SPA500-3020	3020	M-3	65	51	7	-	43.10
565.6	560	3/SPA560-3020	3020	N-3	50	51	-	1	41.12	4/SPA560-3535	*3535	L-3	65	89	-	12	73.63
635.6	630	3/SPA630-3020	3020	N-3	50	51	-	1	48.66	4/SPA630-3535	*3535	L-3	65	89	-	12	82.45

* Caution: Metric sheaves requiring TB bushing 2517 or 3535 MUST use bushings with BSW threads (2517-BSW or 3535-BSW)

SPA Sheaves

Cast Iron Sheaves - **Heavy Duty**

Bushed, **Five Groove**

SPA TB Sheaves

Order part number size

Example: 5/SPA100-1615

For SPA V-Belts

Order TB bushings separately (Pages 87-88)

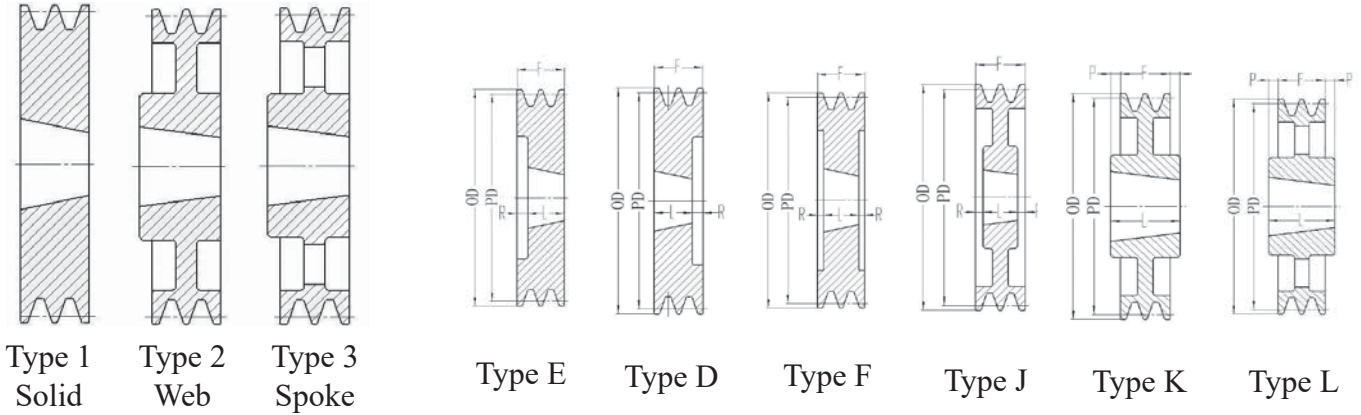

O.D. (mm)	P.D. (mm)	Part No.	Bush	Type	Dimensions (mm)				Wt.
					F	L	R	P	
105.6	100	5/SPA100-1615	1615	E-1	80	38	42	-	4.41
111.6	106	5/SPA106-2012	2012	D-1	80	32	48	-	4.63
117.6	112	5/SPA112-2012	2012	D-1	80	32	48	-	5.18
123.6	118	5/SPA118-2012	2012	E-1	80	32	48	-	5.89
130.6	125	5/SPA125-2012	2012	F-1	80	32	24	-	6.68
137.6	132	5/SPA132-2517	*2517	F-1	80	45	17.5	-	7.05
145.6	140	5/SPA140-2517	*2517	F-1	80	45	17.5	-	8.40
155.6	150	5/SPA150-2517	*2517	F-1	80	45	17.5	-	10.32
165.6	160	5/SPA160-2517	*2517	F-1	80	45	17.5	-	12.04
180.6	180	5/SPA180-3020	3020	F-1	80	51	14.5	-	14.82
205.6	200	5/SPA200-3020	3020	F-1	80	51	14.5	-	19.78
229.6	224	5/SPA224-3020	3020	E-1	80	51	29	-	26.01
255.6	250	5/SPA250-3020	3020	J-2	80	51	14.5	-	23.70
285.6	280	5/SPA280-3535	*3535	K-2	80	89	-	4.5	40.45
320.6	315	5/SPA315-3535	*3535	K-2	80	89	-	4.5	44.31
360.6	355	5/SPA355-3535	*3535	L-3	80	89	-	4.5	44.20
405.6	400	5/SPA400-3535	*3535	L-3	80	89	-	4.5	54.01
455.6	450	5/SPA450-3535	*3535	L-3	80	89	-	4.5	58.42
505.6	500	5/SPA500-3535	*3535	L-3	80	89	-	4.5	68.78
565.6	560	5/SPA560-3535	*3535	L-3	80	89	-	4.5	81.57
635.6	630	5/SPA630-3535	*3535	L-3	80	89	-	4.5	78.48

* Caution: Metric sheaves requiring TB bushing 2517 or 3535 MUST use bushings with BSW threads (2517-BSW or 3535-BSW)

Cast Iron Sheaves - **Heavy Duty**
Bushed, **One and Two Groove**
SPB TB Sheaves

Order part number size

Example: 1/SPB125-1610

For SPB V-Belts

Order TB bushings separately (Pages 87-88)

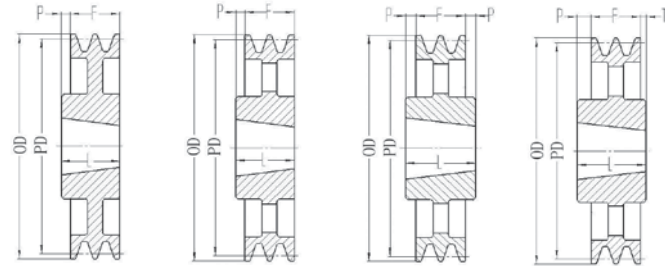
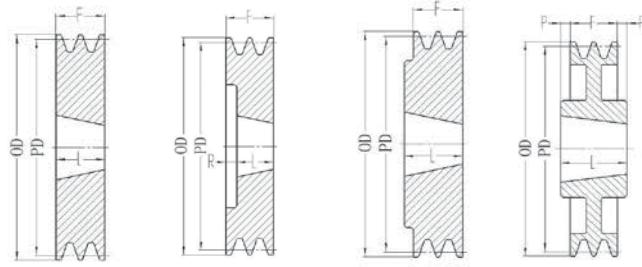
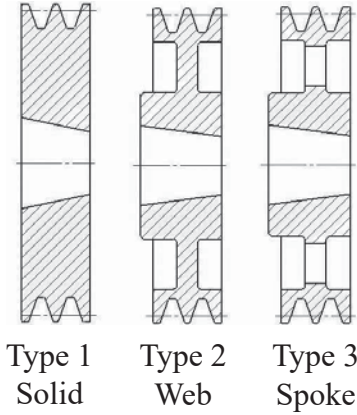

O.D. (mm)	P.D. (mm)	Part No.	Bush	Type	Dimensions (mm)				Wt.	Part No.	Bush	Type	Dimensions (mm)				Wt.
					F	L	R	P					F	L	R	P	
132	125	1/SPB125-1610	1610	A-1	25	25	-	-	3.33	2/SPB125-2012	2012	E-1	45	32	12	-	4.41
139	132	1/SPB132-1610	1610	A-1	25	25	-	-	3.92	2/SPB132-2012	2012	E-1	44	32	12	-	5.29
147	140	1/SPB140-1610	1610	A-1	25	25	-	-	4.56	2/SPB140-2012	2012	E-1	44	32	12	-	6.11
157	150	1/SPB150-1610	1610	K-2	25	25	-	0	4.19	2/SPB150-2012	2012	E-1	44	32	12	-	7.14
167	160	1/SPB160-1610	1610	K-2	25	25	-	0	6.28	2/SPB160-2012	2012	E-1	44	32	12	-	8.55
177	170	1/SPB170-1610	1610	K-2	25	25	-	0	7.32	2/SPB170-2012	2012	E-1	44	32	12	-	9.83
187	180	1/SPB180-1610	1610	K-2	25	25	-	0	5.78	2/SPB180-2517	*2517	C-1	44	45	-	-	12.13
197	190	1/SPB190-2012	2012	K-2	25	32	-	3.5	7.43	2/SPB190-2517	*2517	C-1	44	45	-	-	13.89
207	200	1/SPB200-2012	2012	K-2	25	32	-	3.5	8.16	2/SPB200-2517	*2517	G-2	44	45	-	1	11.75
219	212	1/SPB212-2012	2012	K-2	25	32	-	3.5	9.17	2/SPB212-2517	*2517	G-2	44	45	-	1	14.20
231	224	1/SPB224-2012	2012	K-2	25	32	-	3.5	9.57	2/SPB224-2517	*2517	G-2	44	45	-	1	14.88
243	236	1/SPB236-2012	2012	K-2	25	32	-	3.5	10.63	2/SPB236-2517	*2517	G-2	44	45	-	1	15.43
257	250	1/SPB250-2012	2012	K-2	25	32	-	3.5	11.60	2/SPB250-2517	*2517	G-2	44	45	-	1	18.10
287	280	1/SPB280-2012	2012	L-3	25	32	-	3.5	12.02	2/SPB280-2517	*2517	N-3	44	45	-	1	18.08
307	300									2/SPB300-2517	*2517	N-3	44	45	-	1	20.06
322	315	1/SPB315-2012	2012	L-3	25	32	-	3.5	13.71	2/SPB315-2517	*2517	N-3	44	45	-	1	21.16
342	335									2/SPB335-2517	*2517	N-3	44	45	-	1	29.76
362	355									2/SPB355-3020	3020	L-3	44	51	-	3.5	36.27
407	400									2/SPB400-3020	3020	L-3	44	51	-	3.5	31.26
457	450									2/SPB450-3020	3020	L-3	44	51	-	3.5	35.60
507	500									2/SPB500-3020	3020	L-3	44	51	-	3.5	38.36
567	560									2/SPB560-3030	3030	R-3	44	76	-	28.5	56.92
637	630									2/SPB630-3030	3030	L-3	44	76	-	16	56.00

* Caution: Metric sheaves requiring TB bushing 2517 or 3535 MUST use bushings with BSW threads (2517-BSW or 3535-BSW)

SPB Sheaves

Cast Iron Sheaves - **Heavy Duty**
Bushed, **Three and Four Groove**
SPB TB Sheaves

Order part number size
Example: 3/SPB125-2012

For SPB V-Belts

Order TB bushings separately (Pages 87-88)

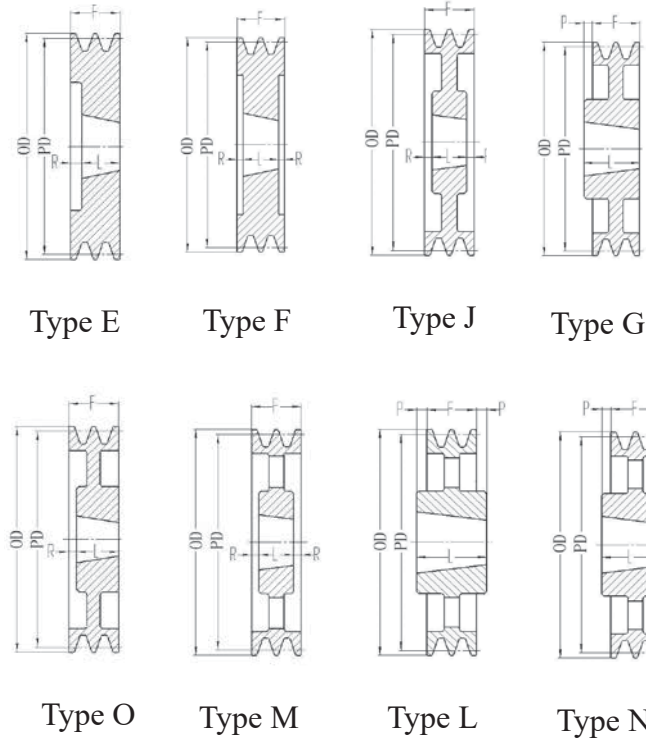
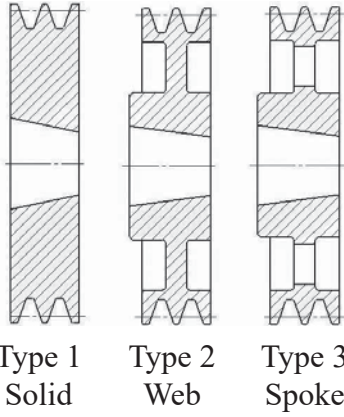

O.D. (mm)	P.D. (mm)	Part No.	Bush	Type	Dimensions (mm)				Wt.	Part No.	Bush	Type	Dimensions (mm)				Wt.
					F	L	R	P					F	L	R	P	
132	125	3/SPB125-2012	2012	E-1	63	32	31	-	5.60	4/SPB125-2012	2012	F-1	82	32	25	-	6.86
139	132	3/SPB132-2012	2012	E-1	63	32	31	-	6.61	4/SPB132-2012	2012	F-1	82	32	25	-	8.18
147	140	3/SPB140-2012	2012	E-1	63	32	31	-	7.74	4/SPB140-2517	*2517	F-1	82	45	18.5	-	8.38
157	150	3/SPB150-2517	*2517	E-1	63	45	18	-	8.80	4/SPB150-2517	*2517	F-1	82	45	18.5	-	10.54
167	160	3/SPB160-2517	*2517	E-1	63	45	18	-	10.60	4/SPB160-2517	*2517	F-1	82	45	18.5	-	13.43
177	170	3/SPB170-2517	*2517	E-1	63	45	18	-	12.13	4/SPB170-2517	*2517	F-1	82	45	18.5	-	14.46
187	180	3/SPB180-2517	*2517	E-1	63	45	18	-	14.40	4/SPB180-2517	*2517	F-1	82	45	18.5	-	16.53
197	190	3/SPB190-2517	*2517	E-1	63	45	18	-	15.65	4/SPB190-2517	*2517	F-1	82	45	18.5	-	18.30
207	200	3/SPB200-2517	*2517	E-1	63	45	18	-	18.96	4/SPB200-3020	3020	F-1	82	51	15.5	-	20.19
219	212	3/SPB212-2517	*2517	O-2	63	45	18	-	17.95	4/SPB212-3020	3020	F-1	82	51	15.5	-	23.48
231	224	3/SPB224-2517	*2517	O-2	63	45	18	-	19.84	4/SPB224-3020	3020	F-1	82	51	15.5	-	27.34
243	236	3/SPB236-2517	*2517	O-2	63	45	18	-	21.16	4/SPB236-3020	3020	J-2	82	51	15.5	-	31.09
257	250	3/SPB250-3020	3020	O-2	63	51	12	-	24.47	4/SPB250-3020	3020	J-2	82	51	15.5	-	27.36
287	280	3/SPB280-3020	3020	M-3	63	51	6	-	27.78	4/SPB280-3020	3020	J-2	82	51	15.5	-	30.86
307	300	3/SPB300-3020	3020	M-3	63	51	6	-	26.28	4/SPB300-3535	*3535	G-2	82	89	-	7	42.99
322	315	3/SPB315-3020	3020	M-3	63	51	6	-	30.42	4/SPB315-3535	*3535	L-3	82	89	-	3.5	44.75
342	335	3/SPB335-3020	3020	M-3	63	51	6	-	29.10	4/SPB335-3535	*3535	L-3	82	89	-	3.5	50.49
362	355	3/SPB355-3020	3020	M-3	63	51	6	-	33.51	4/SPB355-3535	*3535	L-3	82	89	-	3.5	49.16
407	400	3/SPB400-3535	*3535	L-3	63	89	-	13	50.38	4/SPB400-3535	*3535	L-3	82	89	-	3.5	59.97
457	450	3/SPB450-3535	*3535	N-3	63	89	-	26	55.01	4/SPB450-3535	*3535	N-3	82	89	-	7	63.01
507	500	3/SPB500-3535	*3535	N-3	63	89	-	26	59.75	4/SPB500-3535	*3535	N-3	82	89	-	7	71.43
567	560	3/SPB560-3535	*3535	N-3	63	89	-	26	79.37	4/SPB560-3535	*3535	N-3	82	89	-	7	94.36
637	630	3/SPB630-3535	*3535	N-3	63	89	-	26	80.25	4/SPB630-3535	*3535	N-3	82	89	-	7	87.30
717	710	3/SPB710-3535	*3535	L-3	63	89	-	13	97.11	4/SPB710-3535	*3535	L-3	82	89	-	3.5	117.95
807	800	3/SPB800-3535	*3535	L-3	63	89	-	13	110.34	4/SPB800-4040	4040	L-3	82	102	-	10	156.09
907	900									4/SPB900-4040	4040	L-3	82	102	-	10	168.21
1007	1000									4/SPB1000-4040	4040	L-3	82	102	-	10	203.71

Cast Iron Sheaves - **Heavy Duty**
Bushed, **Five and Six Groove**
SPB TB Sheaves

Order part number size
Example: 5/SPB140-2517

For SPB V-Belts

Order TB bushings separately (Pages 87-88)

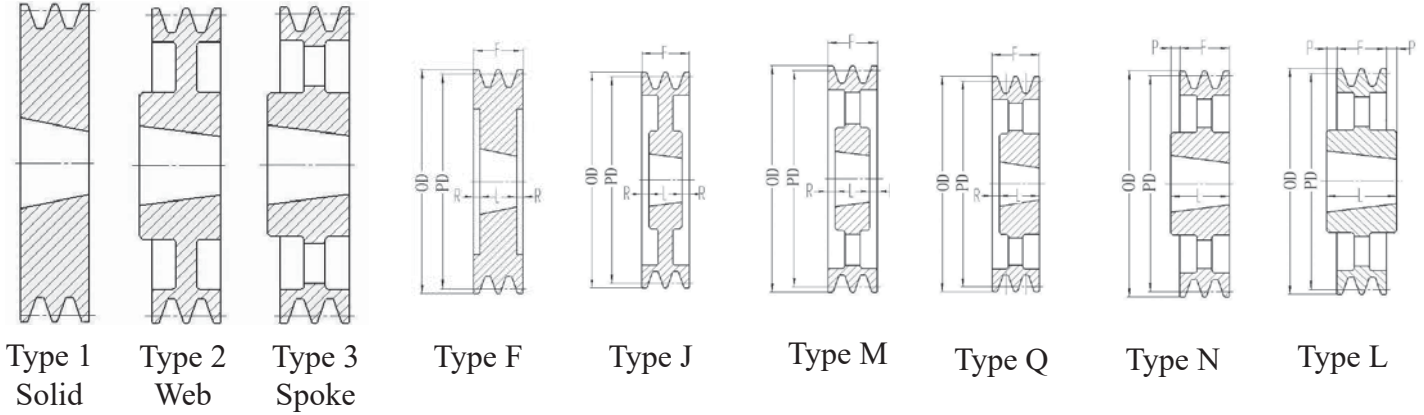

O.D. (mm)	P.D. (mm)	Part No.	Bush	Type	Dimensions (mm)				Wt.	Part No.	Bush	Type	Dimensions (mm)				Wt.
					F	L	R	P					F	L	R	P	
147	140	5/SPB140-2517	*2517	F-1	101	45	28	-	4.85	6/SPB140-2517	*2517	F-1	120	45	37.5	-	10.91
157	150	5/SPB150-2517	*2517	F-1	101	45	28	-	12.37	6/SPB150-2517	*2517	F-1	120	45	37.5	-	13.91
167	160	5/SPB160-2517	*2517	F-1	101	45	28	-	14.15	6/SPB160-3020	3020	F-1	120	51	34.5	-	12.99
177	170	5/SPB170-3020	3020	F-1	101	51	25	-	14.51	6/SPB170-3020	3020	F-1	120	51	34.5	-	16.53
187	180	5/SPB180-3020	3020	F-1	101	51	25	-	17.02	6/SPB180-3020	3020	F-1	120	51	34.5	-	19.07
197	190	5/SPB190-3020	3020	F-1	101	51	25	-	19.40	6/SPB190-3020	3020	F-1	120	51	34.5	-	22.05
207	200	5/SPB200-3020	3020	F-1	101	51	25	-	22.95	6/SPB200-3020	3020	F-1	120	51	34.5	-	25.57
219	212	5/SPB212-3020	3020	F-1	101	51	25	-	26.46	6/SPB212-3535	*3535	F-1	120	89	15.5	-	33.29
231	224	5/SPB224-3020	3020	F-1	101	51	25	-	30.86	6/SPB224-3535	*3535	F-1	120	89	15.5	-	38.80
243	236	5/SPB236-3535	*3535	F-1	101	89	6	-	41.89	6/SPB236-3535	*3535	F-1	120	89	15.5	-	44.97
257	250	5/SPB250-3535	*3535	F-1	101	89	6	-	50.27	6/SPB250-3535	*3535	F-1	120	89	15.5	-	52.91
287	280	5/SPB280-3535	*3535	J-2	101	89	6	-	44.75	6/SPB280-3535	*3535	J-2	120	89	15.5	-	50.71
307	300	5/SPB300-3535	*3535	J-2	101	89	6	-	49.60	6/SPB300-3535	*3535	J-2	120	89	15.5	-	52.03
322	315	5/SPB315-3535	*3535	J-2	101	89	6	-	50.27	6/SPB315-3535	*3535	J-2	120	89	15.5	-	56.22
342	335	5/SPB335-3535	*3535	J-2	101	89	6	-	52.03	6/SPB335-3535	*3535	J-2	120	89	15.5	-	55.12
362	355	5/SPB355-3535	*3535	J-2	101	89	6	-	59.70	6/SPB355-3535	*3535	J-2	120	89	15.5	-	63.05
407	400	5/SPB400-3535	*3535	M-3	101	89	6	-	61.73	6/SPB400-3535	*3535	M-3	120	89	15.5	-	68.78
457	450	5/SPB450-3535	*3535	Q-3	101	89	12	-	72.53	6/SPB450-4040	4040	Q-3	120	102	18	-	94.80
507	500	5/SPB500-3535	*3535	Q-3	101	89	12	-	59.86	6/SPB500-4040	4040	Q-3	120	102	18	-	99.54
567	560	5/SPB560-4040	4040	N-3	101	102	-	1	100.42	6/SPB560-4040	4040	Q-3	120	102	18	-	107.14
637	630	5/SPB630-4040	4040	N-3	101	102	-	1	118.83	6/SPB630-4040	4040	Q-3	120	102	18	-	144.40
717	710	5/SPB710-4040	4040	N-3	101	102	-	1	177.69	6/SPB710-4040	4040	M-2	120	102	9	-	160.94
807	800	5/SPB800-4040	4040	N-3	101	102	-	1	174.16	6/SPB800-4545	4545	M-3	120	114	3	-	203.55
907	900	5/SPB900-4040	4040	N-3	101	102	-	1	192.02	6/SPB900-4545	4545	M-3	120	114	3	-	228.62
1007	1000	5/SPB1000-4545	4545	L-3	101	114	-	6.5	270.73	6/SPB1000-4545	4545	M-3	120	114	3	-	282.63

* Caution: Metric sheaves requiring TB bushing 2517 or 3535 MUST use bushings with BSW threads (2517-BSW or 3535-BSW)

SPB Sheaves

Cast Iron Sheaves - Heavy Duty
Bushed, **Eight and Ten Groove**
SPB TB Sheaves

Order part number size
Example: 8/SPB170-3030

For SPB V-Belts

Order TB bushings separately (Pages 87-88)



Type 1
Solid



Type 2
Web

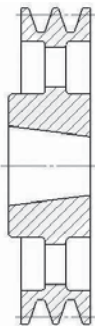

Type 3
Spoke

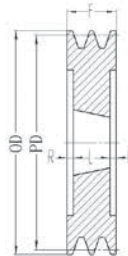

Type F

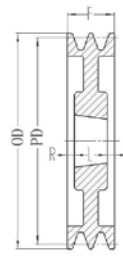

Type J

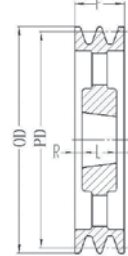

Type M

O.D. (mm)	P.D. (mm)	Part No.	Bush	Type	Dimensions (mm)			Wt.	Part No.	Bush	Type	Dimensions (mm)			Wt.
					F	L	R					F	L	R	
177	170	8/SPB170-3030	3030	F-1	158	76	41	22.71							
187	180	8/SPB180-3030	3030	F-1	158	76	41	24.91							
197	190	8/SPB190-3030	3030	F-1	158	76	41	29.08							
207	200	8/SPB200-3535	*3535	F-1	158	89	34.5	31.53							
219	212	8/SPB212-3535	*3535	F-1	158	89	34.5	37.70							
231	224	8/SPB224-3535	*3535	F-1	158	89	34.5	42.99	10/SPB224-3535	*3535	F-1	196	89	53.5	52.91
243	236	8/SPB236-3535	*3535	F-1	158	89	34.5	63.05	10/SPB236-3535	*3535	F-1	196	89	53.5	63.93
257	250	8/SPB250-3535	*3535	F-1	158	89	34.5	57.76	10/SPB250-3535	*3535	F-1	196	89	53.5	65.04
287	280	8/SPB280-3535	*3535	J-2	158	89	34.5	50.71	10/SPB280-3535	*3535	J-2	196	89	53.5	66.14
307	300	8/SPB300-3535	*3535	J-2	158	89	34.5	62.39							
322	315	8/SPB315-3535	*3535	J-2	158	89	34.5	65.04	10/SPB315-3535	*3535	J-2	196	89	53.5	78.26
342	335	8/SPB335-3535	*3535	J-2	158	89	34.5	68.56	10/SPB335-3535	*3535	J-2	196	89	53.5	91.71
362	355	8/SPB355-3535	*3535	J-2	158	89	34.5	75.84	10/SPB355-4040	4040	J-2	196	102	47	103.62
407	400	8/SPB400-4040	4040	J-2	158	102	28	109.35	10/SPB400-4040	4040	J-2	196	102	47	120.15
457	450	8/SPB450-4040	4040	M-3	158	102	28	99.87	10/SPB450-4545	4545	M-3	196	114	41	110.23
507	500	8/SPB500-4040	4040	M-3	158	102	28	103.11	10/SPB500-4545	4545	M-3	196	114	41	159.39
567	560	8/SPB560-4545	4545	M-3	158	114	22	126.99	10/SPB560-4545	4545	M-3	196	114	41	174.61
637	630	8/SPB630-4545	4545	M-3	158	114	22	174.61	10/SPB630-4545	4545	M-3	196	114	41	195.11
717	710	8/SPB710-4545	4545	M-3	158	114	22	205.47	10/SPB710-4545	4545	M-3	196	114	41	238.10
807	800	8/SPB800-4545	4545	M-3	158	114	22	253.97	10/SPB800-4545	4545	M-3	196	114	41	266.10
907	900	8/SPB900-4545	4545	M-3	158	114	22	247.58	10/SPB900-5050	5050	M-3	196	127	34.5	308.65
1007	1000	8/SPB1000-5050	5050	M-3	158	127	15.5	336.23	10/SPB1000-5050	5050	M-3	196	127	34.5	399.04

* Caution: Metric sheaves requiring TB bushing 2517 or 3535 MUST use bushings with BSW threads (2517-BSW or 3535-BSW)

Cast Iron Sheaves - **Heavy Duty**
Bushed, **Three and Four Groove**
SPC TB Sheaves

Order part number size
Example: 3/SPC200-2517

For SPC V-Belts

Order TB bushings separately (Pages 87-88)

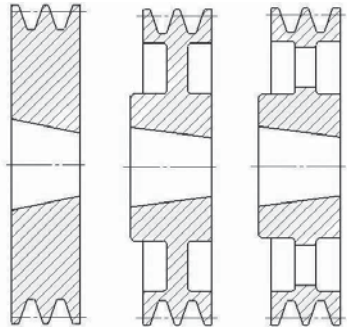

Type 1 Solid Type 2 Web Type 3 Spoke

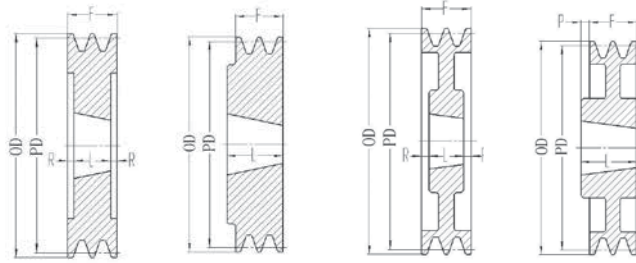

Type F Type C Type J Type G

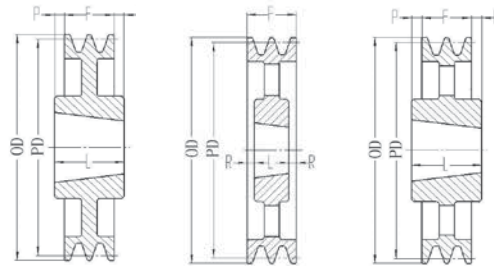

Type K Type M Type L

O.D. (mm)	P.D. (mm)	Part No.	Bush	Type	Dimensions (mm)				Wt.	Part No.	Bush	Type	Dimensions (mm)				Wt.
					F	L	R	P					F	L	R	P	
209.6	200	3/SPC200-2517	*2517	F-1	85	45	20	-	22.49	4/SPC200-3020	3020	F-1	110.5	51	29.8	-	24.91
221.6	212	3/SPC212-3020	3020	F-1	85	51	17	-	24.47	4/SPC212-3020	3020	F-1	110.5	51	29.8	-	28.44
233.6	224	3/SPC224-3020	3020	F-1	85	51	17	-	27.09	4/SPC224-3535	*3535	F-1	110.5	89	10.8	-	31.97
245.6	236	3/SPC236-3020	3020	F-1	85	51	17	-	31.09	4/SPC236-3535	*3535	F-1	110.5	89	10.8	-	44.49
259.6	250	3/SPC250-3020	3020	F-1	85	51	17	-	36.16	4/SPC250-3535	*3535	F-1	110.5	89	10.8	-	48.94
274.6	265	3/SPC265-3535	*3535	C-1	85	89	-	-	43.21	4/SPC265-3535	*3535	F-1	110.5	89	10.8	-	48.50
289.6	280	3/SPC280-3535	*3535	G-2	85	89	-	4	44.09	4/SPC280-3535	*3535	J-2	110.5	89	10.8	-	44.09
309.6	300	3/SPC300-3535	*3535	K-2	85	89	-	2	45.42	4/SPC300-3535	*3535	J-2	110.5	89	10.8	-	55.12
324.6	315	3/SPC315-3535	*3535	K-2	85	89	-	2	46.30	4/SPC315-3535	*3535	J-2	110.5	89	10.8	-	46.30
344.6	335	3/SPC335-3535	*3535	L-3	85	89	-	2	52.69	4/SPC335-3535	*3535	M-3	110.5	89	10.8	-	60.27
364.6	355	3/SPC355-3535	*3535	L-3	85	89	-	2	53.79	4/SPC355-3535	*3535	M-3	110.5	89	10.8	-	60.63
384.6	375	3/SPC375-3535	*3535	L-3	85	89	-	2	57.32	4/SPC375-3535	*3535	M-3	110.5	89	10.8	-	64.24
409.6	400	3/SPC400-3535	*3535	L-3	85	89	-	2	62.17	4/SPC400-3535	*3535	M-3	110.5	89	10.8	-	69.67
434.6	425	3/SPC425-3535	*3535	L-3	85	89	-	2	73.19	4/SPC425-3535	*3535	M-3	110.5	89	10.8	-	81.57
459.6	450	3/SPC450-3535	*3535	L-3	85	89	-	2	73.41	4/SPC450-3535	*3535	M-3	110.5	89	10.8	-	73.41
484.6	475	3/SPC475-3535	*3535	L-3	85	89	-	2	86.84	4/SPC475-3535	*3535	M-3	110.5	89	10.8	-	99.74
509.6	500	3/SPC500-3535	*3535	L-3	85	89	-	2	90.17	4/SPC500-3535	*3535	M-3	110.5	89	10.8	-	90.17
569.6	560									4/SPC560-4040	4040	M-3	110.5	102	4.3	-	121.14
639.6	630	3/SPC630-4040	4040	L-3	85	102	-	8.5	117.95	4/SPC630-4545	4545	L-3	110.5	114	-	1.8	167.88
809.6	800									4/SPC800-5050	5050	L-3	110.5	127	-	8.3	230.16

* Caution: Metric sheaves requiring TB bushing 2517 or 3535 MUST use bushings with BSW threads (2517-BSW or 3535-BSW)

SPC Sheaves

Cast Iron Sheaves - **Heavy Duty**
Bushed, **Five and Six Groove**
SPC TB Sheaves

Order part number size
Example: 5/SPC200-3535

For SPC V-Belts

Order TB bushings separately (Pages 87-88)



Type 1
Solid



Type 2
Web



Type 3
Spoke

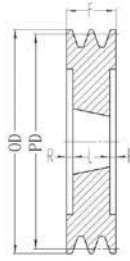

Type F

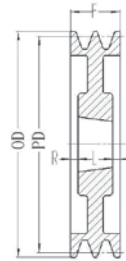

Type J

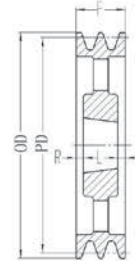

Type M

O.D. (mm)	P.D. (mm)	Part No.	Bush	Type	Dimensions (mm)			Wt.	Part No.	Bush	Type	Dimensions (mm)			Wt.
					F	L	R					F	L	R	
209.6	200	5/SPC200-3535	*3535	F-1	136	89	23.5	29.10	6/SPC200-3535	*3535	F-1	131.5	89	36.3	33.73
221.6	212	5/SPC212-3535	*3535	F-1	136	89	23.5	34.61	6/SPC212-3535	*3535	F-1	161.5	89	36.3	35.49
233.6	224	5/SPC224-3535	*3535	F-1	136	89	23.5	39.68	6/SPC224-3535	*3535	F-1	161.5	89	36.3	42.15
245.6	236	5/SPC236-3535	*3535	F-1	136	89	23.5	42.33	6/SPC236-3535	*3535	F-1	161.5	89	36.3	53.51
259.6	250	5/SPC250-3535	*3535	F-1	136	89	23.5	47.84	6/SPC250-3535	*3535	F-1	161.5	89	36.3	59.08
274.6	265	5/SPC265-3535	*3535	F-1	136	89	23.5	63.93	6/SPC265-3535	*3535	F-1	161.5	89	36.3	71.32
289.6	280	5/SPC280-3535	*3535	J-2	136	89	23.5	60.63	6/SPC280-3535	*3535	J-2	161.5	89	36.3	63.38
309.6	300	5/SPC300-3535	*3535	J-2	136	89	23.5	57.98	6/SPC300-3535	*3535	J-2	161.5	89	36.3	64.37
324.6	315	5/SPC315-3535	*3535	J-2	136	89	23.5	59.97	6/SPC315-3535	*3535	J-2	161.5	89	36.3	67.46
344.6	335	5/SPC335-3535	*3535	J-2	136	89	23.5	68.56	6/SPC335-3535	*3535	J-2	161.5	89	36.3	75.18
364.6	355	5/SPC355-3535	*3535	M-3	136	89	23.5	70.11	6/SPC355-3535	*3535	J-2	161.5	89	36.3	84.22
384.6	375	5/SPC375-3535	*3535	M-3	136	89	23.5	74.52	6/SPC375-4040	4040	J-2	161.5	102	29.8	96.56
409.6	400	5/SPC400-3535	*3535	M-3	136	89	23.5	85.10	6/SPC400-4040	4040	J-2	161.5	102	29.8	104.28
434.6	425	5/SPC425-3535	*3535	M-3	136	89	23.5	92.15	6/SPC425-4040	4040	J-2	161.5	102	29.8	121.58
459.6	450	5/SPC450-4040	4040	M-3	136	102	17	117.73	6/SPC450-4545	4545	J-2	161.5	114	23.8	139.77
484.6	475	5/SPC475-4040	4040	M-3	136	102	17	123.90	6/SPC475-4545	4545	J-2	161.5	114	23.8	142.64
509.6	500	5/SPC500-4040	4040	M-3	136	102	17	134.04	6/SPC500-4545	4545	M-3	161.5	114	23.8	149.91
569.6	560	5/SPC560-4545	4545	M-3	136	114	11	164.69	6/SPC560-5050	5050	M-3	161.5	127	17.3	189.38
639.6	630	5/SPC630-5050	5050	M-3	136	127	4.5	205.91	6/SPC630-5050	5050	M-3	161.5	127	17.3	220.24
719.6	710	5/SPC710-5050	5050	M-3	136	127	4.5	231.71	6/SPC710-5050	5050	M-3	161.5	127	17.3	266.98
809.6	800	5/SPC800-5050	5050	M-3	136	127	4.5	274.48	6/SPC800-5050	5050	M-3	161.5	127	17.3	327.61
1009.6	1000	5/SPC1000-5050	5050	M-3	136	127	4.5	358.91	6/SPC1000-5050	5050	M-3	161.5	127	17.3	418.88
1259.6	1250	5/SPC1250-5050	5050	M-3	136	127	4.5	465.17	6/SPC1250-5050	5050	M-3	161.5	127	17.3	487.44

* Caution: Metric sheaves requiring TB bushing 2517 or 3535 MUST use bushings with BSW threads (2517-BSW or 3535-BSW)

Cast Iron Sheaves - **Heavy Duty**
Bushed, **Eight and Ten Groove**
SPC TB Sheaves

Order part number size

Example: 8/SPC224-3535

For SPC V-Belts

Order TB bushings separately (Pages 87-88)



Type 1
Solid

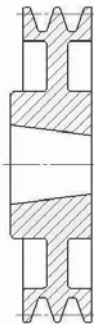

Type 2
Web

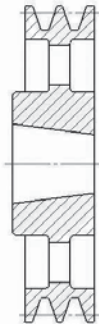

Type 3
Spoke

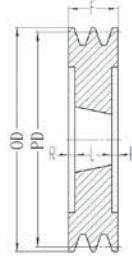

Type F

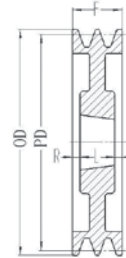

Type J

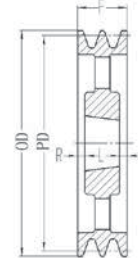

Type M

O.D. (mm)	P.D. (mm)	Part No.	Bush	Type	Dimensions (mm)			Wt.	Part No.	Bush	Type	Dimensions (mm)			Wt.
					F	L	R					F	L	R	
233.6	224	8/SPC224-3535	*3535	F-1	212.5	89	61.8	52.69							
245.6	236	8/SPC236-3535	*3535	F-1	212.5	89	61.8	60.41							
259.6	250	8/SPC250-3535	*3535	F-1	212.5	89	61.8	67.46	10/SPC250-4040	4040	F-1	263.5	102	80.8	75.18
274.6	265	8/SPC265-3535	*3535	F-1	212.5	89	61.8	70.55							
289.6	280	8/SPC280-3535	*3535	F-1	212.5	89	61.8	80.73	10/SPC280-4040	4040	F-1	263.5	102	80.8	99.65
309.6	300	8/SPC300-4040	4040	F-1	212.5	102	55.3	106.04	10/SPC300-4545	4545	F-1	263.5	114	74.8	116.18
324.6	315	8/SPC315-4040	4040	F-1	212.5	102	55.3	117.51	10/SPC315-4545	4545	F-1	263.5	114	74.8	135.36
344.6	335	8/SPC335-4040	4040	J-2	212.5	102	55.3	120.26							
364.6	355	8/SPC355-4040	4040	J-2	212.5	102	55.3	105.60	10/SPC355-4545	4545	F-1	263.5	102	80.8	174.16
384.6	375	8/SPC375-4545	4545	J-2	212.5	114	49.3	131.40							
409.6	400	8/SPC400-4545	4545	J-2	212.5	114	49.3	133.38	10/SPC400-5050	5050	J-2	263.5	127	68.3	165.13
434.6	425	8/SPC425-4545	4545	J-2	212.5	114	49.3	151.68							
459.6	450	8/SPC450-5050	5050	J-2	212.5	127	42.8	177.47	10/SPC450-5050	5050	J-2	263.5	127	68.3	199.52
484.6	475	8/SPC475-5050	5050	J-2	212.5	127	42.8	194.01							
509.6	500	8/SPC500-5050	5050	J-2	212.5	127	42.8	192.90	10/SPC500-5050	5050	J-2	263.5	127	68.3	233.91
569.6	560	8/SPC560-5050	5050	M-3	212.5	127	42.8	225.91	10/SPC560-5050	5050	M-3	263.5	127	68.3	250.22
639.6	630	8/SPC630-5050	5050	M-3	212.5	127	42.8	257.06	10/SPC630-5050	5050	M-3	263.5	127	68.3	330.69
719.6	710	8/SPC710-5050	5050	M-3	212.5	127	42.8	324.08	10/SPC710-5050	5050	M-3	263.5	127	68.3	368.61
809.6	800	8/SPC800-5050	5050	M-3	212.5	127	42.8	363.76	10/SPC800-5050	5050	M-3	263.5	127	68.3	434.31
1009.6	1000	8/SPC1000-5050	5050	M-3	212.5	127	42.8	489.65	10/SPC1000-5050	5050	M-3	263.5	127	68.3	508.61
1259.6	1250	8/SPC1250-5050	5050	M-3	212.5	127	42.8	639.34	10/SPC1250-5050	5050	M-3	263.5	127	68.3	791.70

* Caution: Metric sheaves requiring TB bushing 2517 or 3535 MUST use bushings with BSW threads (2517-BSW or 3535-BSW)

QD Bushings

JA-N bushings are reverse mountable

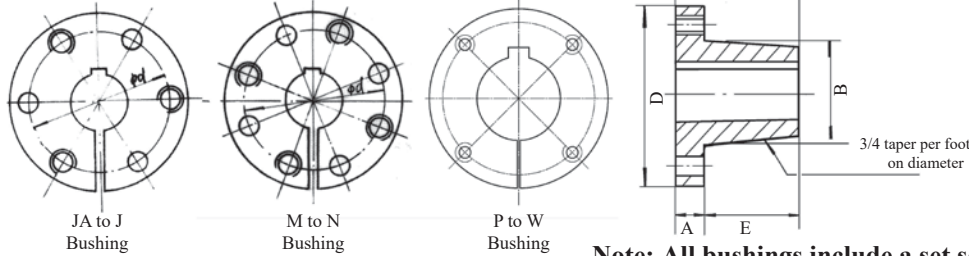

Note: All bushings include a set screw over the keyway. Except JA.

QD Bushings - Dimensions (inches)

Bushing	A	B	D	E	L	Ø d bolt Required	Cap Screws Grade 5		Set Screw Size
							Qty.	Size	
JA	5/16	1.375	2	11/16	1	1 21/32	3	10 x 1	-
SH	7/16	1.871	2 11/16	7/8	1 5/16	2 1/4	3	1/4 x 1 3/8	1/4
SDS	7/16	2.187	3 1/8	7/8	1 5/16	2 11/16	3	1/4 x 1 3/8	1/4
SD	7/16	2.187	3 1/8	1 3/8	1 13/16	2 11/16	3	1/4 x 1 7/8	1/4
SK	9/16	2.812	3 7/8	1 3/8	1 15/16	3 5/16	3	5/16 x 2	5/16
SF	5/8	3.125	4 5/8	1 7/16	2 1/16	3 7/8	3	3/8 x 2	3/8
E	7/8	3.834	6	1 7/8	2 3/4	5	3	1/2 x 2 3/4	3/8
F	1	4.437	6 5/8	2 3/4	3 3/4	5 5/8	3	9/16 x 3 5/8	1/2
J	1 1/8	5.148	7 1/4	3 1/2	4 5/8	6 1/4	3	5/8 x 4 1/2	5/8
M	1 1/4	6.500	9	5 1/2	6 3/4	7 7/8	4	3/4 x 6 3/4	3/4
N	1 1/2	7.000	10	6 5/8	8 1/8	8 1/2	4	7/8 x 8	3/4
P	1 3/4	8.250	11 3/4	7 5/8	9 3/8	10	4	1 x 9 1/2	3/4
W	2	10.437	15	9 3/8	11 3/8	12 3/4	4	1 1/8 x 11 1/2	3/4

Bushing	Bore Range-inch	Key Seat-inch	Wt.
JA	1/2, 9/16.....	1/8 x 1/16	.50
	5/8, 11/16, 3/4, 13/16, 7/8.....	3/16 x 3/32	.45
	15/16, 1.....	1/4 x 1/8	.35
	1 1/16, 1 1/8, 1 3/16.....	1/4 x 1/16 *	.35
	1 1/4.....	No Key	.30
SH	1/2, 9/16.....	1/8 x 1/16	1.20
	5/8, 11/16, 3/4, 13/16, 7/8.....	3/16 x 3/32	1.20
	15/16, 1, 1 1/16, 1 1/8, 1 3/16, 1 1/4.....	1/4 x 1/8	.95
	1 1/4†, 1 5/16, 1 3/8.....	5/16 x 5/32	.80
	1 7/16, 1 1/2, 1 9/16, 1 5/8.....	3/8 x 1/16 *	.75
	1 11/16.....	No Key	.60
SDS	1/2, 9/16.....	1/8 x 1/16	1.70
	5/8, 11/16, 3/4, 13/16, 7/8.....	3/16 x 3/32	1.65
	7/8†, 15/16, 1, 1 1/16, 1 1/8, 1 3/16, 1 1/4.....	1/4 x 1/8	1.45
	1 1/4†, 1 5/16, 1 3/8.....	5/16 x 5/32	1.30
	1 3/8†, 1 7/16, 1 1/2, 1 9/16, 1 5/8, 1 11/16.....	3/8 x 3/16	1.10
	1 3/4.....	3/8 x 1/8 *	1.00
	1 13/16.....	1/2 x 1/8 *	1.00
	1 7/8, 1 15/16.....	1/2 x 1/16 *	.90
	2.....	No Key	.80
SD	1/2, 9/16.....	1/8 x 1/16	2.00
	5/8, 11/16, 3/4, 13/16, 7/8.....	3/16 x 3/32	2.00
	15/16, 1, 1 1/16, 1 1/8, 1 3/16, 1 1/4.....	1/4 x 1/8	1.80
	1 1/4†, 1 5/16, 1 3/8.....	5/16 x 5/32	1.60
	1 3/8†, 1 7/16, 1 1/2, 1 9/16, 1 5/8, 1 11/16.....	3/8 x 3/16	1.40
	1 3/4.....	3/8 x 1/8 *	1.20
	1 13/16.....	1/2 x 1/8 *	1.20
	1 7/8, 1 15/16.....	1/2 x 1/16 *	1.00
	2.....	No Key	.80
SK	1/2, 9/16.....	1/8 x 1/16	3.80
	5/8, 11/16, 3/4, 13/16, 7/8.....	3/16 x 3/32	3.75
	15/16, 1, 1 1/16, 1 1/8, 1 3/16, 1 1/4.....	1/4 x 1/8	3.50
	1 1/4†, 1 5/16, 1 3/8.....	5/16 x 5/32	3.25
	1 5/16†, 1 3/8†, 1 7/16, 1 1/2, 1 9/16, 1 5/8,.....	3/8 x 3/16	3.00
	1 11/16, 1 3/4, 1 7/8+.....	3/8 x 3/16	2.75
	1 3/4†, 1 13/16, 1 7/8, 1 15/16, 2, 2 1/16, 2 1/8.....	1/2 x 1/4	2.40
	2 3/16, 2 1/4.....	1/2 x 1/8 *	2.00
	2 1/4†, 2 5/16, 2 3/8, 2 7/16, 2 1/2.....	5/8 x 1/16 *	1.75
	2 9/16, 2 5/8.....	No Key	1.20

Bushing	Bore Range-inch	Key Seat-inch	Wt.
SF	1/2, 9/16.....	1/8 x 1/16	5.45
	5/8, 3/4, 7/8.....	3/16 x 3/32	5.25
	15/16, 1, 1 1/16, 1 1/8, 1 3/16, 1 1/4.....	1/4 x 1/8	5.00
	1 5/16, 1 3/8.....	5/16 x 5/32	4.80
	1 3/8†, 1 7/16, 1 1/2, 1 9/16, 1 5/8,.....	3/8 x 3/16	4.50
	1 11/16, 1 3/4.....	3/8 x 3/16	4.25
	1 13/16, 1 7/8, 1 15/16, 2, 2 1/16.....	1/2 x 1/4	4.00
	2 1/8, 2 3/16, 2 1/4.....	1/2 x 1/4	3.55
	2 1/4†.....	5/8 x 5/16	3.50
	2 5/16, 2 3/8, 2 7/16, 2 1/2.....	5/8 x 3/16 *	3.30
	2 9/16, 2 5/8, 2 11/16, 2 3/4.....	5/8 x 1/16 *	2.80
	2 13/16, 2 7/8.....	3/4 x 1/16 *	2.45
	2 15/16.....	No Key	2.30
E	7/8, 15/16.....	3/16 x 3/32	11.45
	1, 1 1/8, 1 3/16, 1 1/4.....	1/4 x 1/8	11.30
	1 5/16, 1 3/8.....	5/16 x 5/32	11.00
	1 3/8†, 1 7/16, 1 1/2, 1 9/16, 1 5/8,.....	3/8 x 3/16	10.60
	1 11/16, 1 3/4.....	3/8 x 3/16	10.30
	1 13/16, 1 7/8, 1 15/16, 2, 2 1/16,.....	1/2 x 1/4	9.80
	2 1/8, 2 3/16, 2 1/4.....	1/2 x 1/4	9.30
	2 1/4†, 2 5/16, 2 3/8, 2 7/16, 2 1/2,.....	5/8 x 5/16	8.70
	2 9/16, 2 5/8, 2 11/16, 2 3/4.....	5/8 x 5/16	8.00
	2 13/16, 2 7/8, 2 15/16, 3, 3 1/8, 3 3/16, 3 1/4... 3 5/16, 3 3/8, 3 7/16, 3 1/2.....	3/4 x 1/8 *	7.00
		7/8 x 1/16 *	5.80

Note: JA, SH, SDS, SD, SK, SF, E, F, J & M Bushings are machined out of ductile iron.

* Shallow Keyseat - Keystock supplied with bushing

† Oversize Key

+ Undersize Key

Note: A rectangular key is supplied with bushings that have shallow keyseats. This key will fit the standard depth keyseat on the shaft and the shallow keyseat on the bushing.

Ordering Example: (JA1.1/16)

Bushing	Bore Range-inch	Key Seat-inch	Wt.	
F	1, 1 1/8, 1 3/16, 1 1/4.....	1/4 x 1/8	18.60	
	1 3/8.....	5/16 x 5/32	18.60	
	1 7/16, 1 1/2, 1 9/16, 1 5/8, 1 11/16, 1 3/4.....	3/8 x 3/16	18.00	
	1 13/16, 1 7/8, 1 15/16, 2, 2 1/16.....	1/2 x 1/4	16.80	
	2 1/8, 2 3/16, 2 1/4.....	1/2 x 1/4	16.00	
	2 1/4†, 2 5/16, 2 3/8, 2 7/16, 2 1/2, 2 9/16.....	5/8 x 5/16	15.50	
	2 5/8, 2 11/16, 2 3/4.....	5/8 x 5/16	14.20	
	2 13/16, 2 7/8, 2 15/16, 3, 3 1/8, 3 3/16, 3 1/4...	3/4 x 3/8	12.50	
	3 5/16, 3 3/8, 3 7/16, 3 1/2, 3 5/8, 3 11/16.....	7/8 x 3/16 *	10.50	
	3 3/4.....	7/8 x 3/16 *	9.80	
	3 7/8, 3 15/16.....	1 x 1/8 *	9.00	
	4.....	No Key	7.90	
	J	1 7/16, 1 1/2, 1 11/16, 1 3/4.....	3/8 x 3/16	28.00
		1 7/8, 1 15/16, 2, 2 1/16, 2 1/8, 2 3/16, 2 1/4....	1/2 x 1/4	26.50
2 5/16, 2 3/8, 2 7/16, 2 1/2, 2 5/8.....		5/8 x 5/16	24.50	
2 11/16, 2 3/4.....		5/8 x 5/16	23.50	
2 7/8, 2 15/16, 3, 3 1/8, 3 3/16, 3 1/4.....		3/4 x 3/8	21.50	
3 5/16, 3 3/8, 3 7/16, 3 1/2.....		7/8 x 7/16	19.50	
3 5/8, 3 11/16, 3 3/4.....		7/8 x 7/16	17.80	
3 13/16, 3 7/8, 3 15/16.....		1 x 3/8 *	17.50	
4, 4 1/8, 4 3/16, 4 1/4, 4 3/8, 4 7/16, 4 1/2.....		1 x 1/8 *	14.00	
M		1 15/16, 2, 2 3/16, 2 1/4.....	1/2 x 1/4	61.50
		2 3/8, 2 7/16, 2 1/2, 2 5/8, 2 11/16, 2 3/4.....	5/8 x 5/16	57.00
	2 7/8, 2 15/16, 3, 3 1/8, 3 3/16, 3 1/4.....	3/4 x 3/8	53.50	
	3 3/8, 3 7/16, 3 1/2, 3 5/8, 3 11/16, 3 3/4.....	7/8 x 7/16	50.00	
	3 13/16, 3 7/8, 3 15/16, 4, 4 1/8, 4 3/16, 4 1/4,..	1 x 1/2	45.00	
	4 3/8, 4 7/16, 4 1/2.....	1 x 1/2	40.00	
	4 5/8, 4 11/16, 4 3/4.....	1 1/4 x 5/8	37.00	
	4 7/8, 4 15/16, 5, 5 3/16, 5 1/4, 5 3/8, 5 7/16.....	1 1/4 x 1/4 *	34.00	
	5 1/2.....	1 1/4 x 1/4 *	28.70	
	N	2 15/16, 3, 3 1/4.....	3/4 x 3/8	80.00
3 3/8, 3 7/16, 3 1/2.....		7/8 x 7/16	76.50	
3 5/8, 3 3/4.....		7/8 x 7/16	73.50	
3 7/8, 3 15/16, 4, 4 3/16, 4 1/4, 4 3/8, 4 7/16.....		1 x 1/2	68.00	
4 1/2.....		1 x 1/2	63.00	
4 5/8, 4 3/4, 4 7/8, 4 15/16, 5.....		1 1/4 x 5/8	58.00	
5 3/16, 5 1/4, 5 7/16, 5 1/2.....		1 1/4 x 1/4 *	53.00	
5 7/8.....		1 1/2 x 1/4 *	44.00	
6.....		1 1/2 x 1/8 *	44.00	
P		3 3/4.....	7/8 x 7/16	97.00
	3 15/16, 4 7/16, 4 1/2.....	1 x 1/2	122.00	
	4 7/8, 4 15/16, 5, 5 7/16, 5 1/2.....	1 1/4 x 5/8	115.00	
	5 15/16.....	1 1/2 x 3/4	95.00	
	6, 6 7/16.....	1 1/2 x 1/4 *	95.00	
	6 3/4, 7.....	1 3/4 x 1/8 *	97.00	
W	5 3/4, 6, 6 1/2.....	1 1/2 x 3/4	190.00	
	6 3/4, 7, 7 1/4, 7 1/2.....	1 3/4 x 7/8	200.00	
	7 3/4, 8, 8 1/2.....	2 x 1/4 *	198.00	

Note: JA, SH, SDS, SD, SK, SF, E, F, J & M Bushings are machined out of ductile iron.

Bushing	Bore Range-mm	Key Seat-mm	Wt.
JA	15, 16	5 x 2.3	.50
	19, 20, 22	6 x 2.8	.40
	24, 25, 28	8 x 3.3	.40
SH	15	5 x 2.3	1.20
	20, 22	6 x 2.8	1.15
	24, 25	8 x 3.3	1.00
	28, 30	8 x 3.3	.95
	32, 35	10 x 3.3	.80
	38	10 x 2.8	.70
SDS	15	5 x 2.3	1.50
	20	6 x 2.8	1.50
	24, 25, 28, 30	8 x 3.3	1.50
	32, 35, 38	10 x 3.3	1.30
SD	40, 42	12 x 3.3	1.10
	24, 25, 28, 30	8 x 3.3	1.80
	32, 35, 38	10 x 3.3	1.60
SK	40, 42	12 x 3.3	1.30
	14	5 x 2.3	3.80
	20	6 x 2.8	3.30
	24, 25, 28, 30	8 x 3.3	3.50
	32, 35, 38	10 x 3.3	3.20
SF	40, 42	12 x 3.3	3.00
	45, 48, 50	14 x 3.8	2.50
	55	16 x 4.3	2.10
	60	18 x 0.6	1.70
	28, 30	8 x 3.3	5.00
	32, 35, 38	10 x 3.3	4.70
E	40, 42	12 x 3.3	4.50
	45, 48, 50	14 x 3.8	4.00
	55	16 x 4.3	3.60
	60, 65	18 x 4.4	3.00
	70, 75	20 x 4.9	7.50
	80	22 x 4.4	6.50
	35, 38	10 x 3.3	10.90
F	40, 42	12 x 3.3	10.50
	45, 48, 50	14 x 3.8	10.00
	55	16 x 4.3	9.30
	60, 65	18 x 4.4	8.60
	70, 75	20 x 4.9	7.50
	80	22 x 4.4	6.50
J	42	12 x 3.3	17.80
	45, 48, 50	14 x 3.8	17.10
	55	16 x 4.3	16.40
	60, 65	18 x 4.4	15.20
	70, 75	20 x 4.9	13.50
M	80, 85	22 x 5.4	11.00
	90	25 x 5.4	10.30
	50	14 x 3.8	27.00
	55	16 x 4.3	26.20
	60, 65	18 x 4.8	24.50
	70, 75	20 x 4.9	22.90
	80, 85	22 x 5.4	20.80
	90, 95	25 x 5.4	18.00
	100	28 x 6.4	18.20
	80	22 x 5.4	54.40
N	90	25 x 5.4	50.80
	100	28 x 6.4	46.00
	120	32 x 7.4	37.40
P	90	25 x 5.4	72.30
	100	28 x 6.4	72.30
W	115, 120	32 x 7.4	59.75
	120	32 x 7.4	100.00
	150	36 x 8.4	95.80

Ordering Example: (JA15MM) or (E35MM)

* Shallow Keyseat - (Ductile Iron) Keystock supplied with bushing

† Oversize Key

Note: A rectangular key is supplied with bushings that have shallow keyseats. This key will fit the standard depth keyseat on the shaft and the shallow keyseat on the bushing.

Ordering Example: (F1) or (F1.1/8) or (N5.7/8)

QD bushing sizes JA through N can be assembled in either of the two positions shown below. Sizes P through S should be assembled in position one. *Position One* is the conventional or standard mounting. *Position Two* (Reverse Mounting) may be necessary in some cases, such as mounting small sheaves with blind holes (not drilled through).

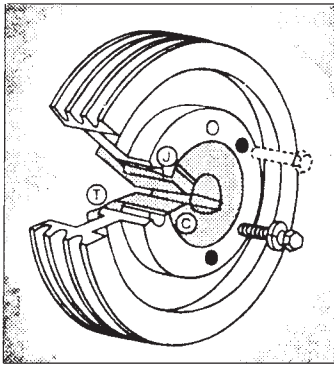

Position 1

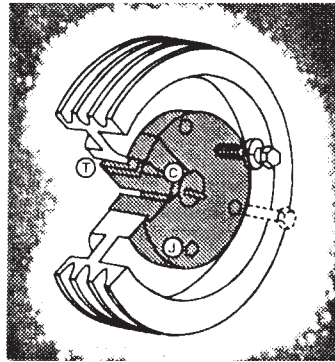

Position 2

Bushing Size	Cap Screw Size-Thread	Foot Pounds Wrench Torque*
JA	10-24	3
SH-SDS-SD	1/4-20	6
SK	5/16-18	10
SF	3/8-16	20
E	1/2-13	40
F	9/16-12	50
J	5/8-11	90
M	3/4-10	150
N	7/8-9	200
P	1-8	300
W	1-1/8-7	400
S	1-1/4-7	500

*For Normal Applications. For Severe (Rock-crusher type) applications these values can be increased by a maximum of 50%

Caution: Excessive cap-screw torque can cause sheave and/or bushing breakage. The use of lubricants can cause sheave breakage.

Therefore,

DO NOT USE LUBRICANTS IN THIS INSTALLATION!

INSTALLATION:

1. Make sure the tapered-cone surface of the bushing and the mating bore of the sheave are free of all foreign substances, such as dirt, excess paint accumulations, metal chips, lubricants, etc.
2. For position one or two (whichever applies), line up the unthreaded holes (C) with the threaded holes (t) and insert cap screws with lock washers engaging only two or three threads. (*a)
3. With key in shaft keyway, slide the loosely-assembled unit onto shaft and position for good belt alignment. (*b, *c) **Use no lubricants or anti-seize compound on threads or tapered surfaces.**
4. Carefully tighten the capscrews alternately and progressively until the tapers are seated (at approximately half the recommended torque).
5. Check alignment and sheave runout (wobble) and correct as necessary.
6. Continue careful alternate and progressive tightening of the cap screws to the recommended torque values shown in the table. **Maximum torque should be achieved on each individual bolt only two times in the consecutive tightening.**

Note: When properly mounted, there will be a gap between the bushing flange and sheave after the screws are tightened.

Caution: Use of Lubricants and or excessive screw torque can cause breakage

7. Tighten the set screw, when available, to hold the key securely during installation and until cap screws are securely tightened.

REMOVAL

1. Loosen and remove all mounting cap screws.
2. Insert cap screws in all threaded jack screw holes (J).
3. Start with the screws furthest from the bushing saw slot and tighten all jack screws alternately and progressively. Keep turning the screws in small equal amounts until the tapered surfaces disengage.

(*a) When mounting a sheave on M through W size bushing, position the threaded jack-apart hole (J) as far from the bushing saw as possible to reduce the possibility of bushing breakage.

(*b) When installing large or heavy parts in *Position One*, it may be easier to mount the key and bushing on the shaft first. Then place the sheave on the bushing and align the holes.

(*c) **Caution:** When mounting on a vertical shaft, provisions must be made, which will positively prevent the sheave and/or bushing from dropping during installation.

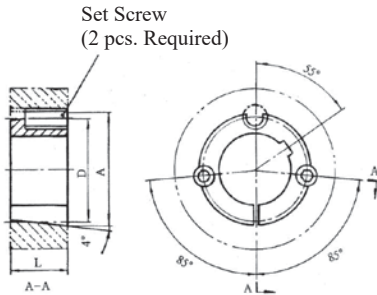

Set Screw
(2 pcs. Required)

Socket Head
Cap Screws (3 pcs. Required)

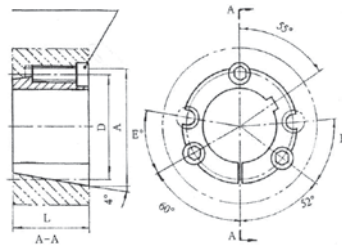

TB Bushing Dimensions				Set Screws
Bushing	L	A	D	Dia. x Length
1008	7/8	1.386	1 21/64	1/4-20 x 1/2
1108	7/8	1.511	1 29/64	1/4-20 x 1/2
1210	1	1.875	1 3/4	3/8-16 x 5/8
1215	1 1/2	1.875	1 3/4	3/8-16 x 5/8
1310	1	2.000	1 7/8	3/8-16 x 5/8
1610	1	2.250	2 1/8	3/8-16 x 5/8
1615	1 1/2	2.250	2 1/8	3/8-16 x 5/8
2012	1 1/4	2.750	2 5/8	7/16-14 x 7/8
2517	1 3/4	3.375	3 1/4	1/2-13 x 1
**2517-BSW	1 3/4	3.375	3 1/4	1/2-12 x 1
2525	2 1/2	3.375	3 1/4	1/2-13 x 1
3020	2	4.250	4	5/8-11 x 1 1/4
3030	3	4.250	4	5/8-11 x 1 1/4

TB Bushing Dimensions				Set Screws	Cap Screws
Bushing	L	A	D	Dia. x Length	E
3535	3 1/2	5	4.83	1/2-13 x 1 1/2	39°
**3535-BSW	3 1/2	5	4.83	1/2-12 x 1 1/2	39°
4040	4	5 3/4	5.54	5/8-11 x 1 3/4	40°
4545	4 1/2	6 3/8	6.13	3/4-10 x 2	40°
5050	5	7	6.72	7/8-9 x 2 1/4	37°

Bushing	Bore Range-inch	Key Seat- inch	Wt.
1008	1/2, 9/16	1/8 x 1/16	.27
	5/8, 11/16, 3/4, 13/16, 7/8	3/16 x 3/32	.21
	15/16, 1	1/4 x 1/16*	.16
1108	1/2, 9/16	1/8 x 1/16	.33
	5/8, 11/16, 3/4, 13/16, 7/8	3/16 x 3/32	.27
	15/16, 1	1/4 x 1/8	.22
	1 1/16, 1 1/8	1/4 x 1/16*	.17
1210	1/2, 9/16	1/8 x 1/16	.61
	5/8, 11/16, 3/4, 13/16, 7/8	3/16 x 3/32	.55
	15/16, 1, 1 1/16, 1 1/8, 1 3/16, 1 1/4	1/4 x 1/8	.49
1215	1/2, 9/16	1/8 x 1/16	.80
	5/8, 11/16, 3/4, 13/16, 7/8	3/16 x 3/32	.70
	15/16, 1, 1 1/16, 1 1/8, 1 3/16, 1 1/4	1/4 x 1/8	.60
1310	1/2, 9/16	1/8 x 1/16	.70
	5/8, 11/16, 3/4, 13/16, 7/8	3/16 x 3/32	.70
	15/16, 1, 1 1/16, 1 1/8, 1 3/16, 1 1/4	1/4 x 1/8	.60
	1 5/16, 1 3/8	5/16 x 5/32	.60
1610	1/2, 9/16	1/8 x 1/16	.90
	5/8, 11/16, 3/4, 13/16, 7/8	3/16 x 3/32	.80
	15/16, 1, 1 1/16, 1 1/8, 1 3/16, 1 1/4	1/4 x 1/8	.70
	1 5/16, 1 3/8	5/16 x 5/32	.70
	1 7/16, 1 1/2	3/8 x 3/16	.70
	1 9/16, 1 5/8	3/8 x 1/8*	.70
1615	1/2, 9/16	1/8 x 1/16	1.20
	5/8, 11/16, 3/4, 13/16, 7/8	3/16 x 3/32	1.20
	15/16, 1, 1 1/16, 1 1/8, 1 3/16, 1 1/4	1/4 x 1/8	1.20
	1 5/16, 1 3/8	5/16 x 5/32	1.20
	1 7/16, 1 1/2	3/8 x 3/16	.80
	1 9/16, 1 5/8	3/8 x 1/8*	.70
2012	1/2, 9/16	1/8 x 1/16	1.60
	5/8, 11/16, 3/4, 13/16, 7/8	3/16 x 3/32	1.50
	15/16, 1, 1 1/16, 1 1/8, 1 3/16, 1 1/4	1/4 x 1/8	1.50
	1 5/16, 1 3/8	5/16 x 5/32	1.40
	1 7/16, 1 1/2, 1 9/16, 1 5/8, 1 11/16, 1 3/4	3/8 x 3/16	1.20
	1 13/16, 1 7/8	1/2 x 1/4	1.20
	1 15/16, 2	1/2 x 3/16*	1.00

Bushing	Bore Range-inch	Key Seat- inch	Wt.
2517	1/2	1/8 x 1/16	3.50
&	5/8, 11/16, 3/4, 13/16, 7/8	3/16 x 3/32	3.30
**2517-BSW	15/16, 1, 1 1/16, 1 1/8, 1 3/16, 1 1/4	1/4 x 1/8	3.30
	1 5/16, 1 3/8	5/16 x 5/32	3.20
	1 7/16, 1 1/2, 1 9/16, 1 5/8, 1 11/16, 1 3/4	3/8 x 3/16	3.00
	1 13/16, 1 7/8, 1 15/16, 2, 2 1/16, 2 1/8, 2 3/16, 2 1/4	1/2 x 1/4	2.40
	2 5/16, 2 3/8, 2 7/16, 2 1/2	5/8 x 3/16*	1.90
2525	3/4, 7/8	3/16 x 3/32	4.70
	15/16, 1, 1 1/16, 1 1/8, 1 3/16, 1 1/4	1/4 x 1/8	4.70
	1 5/16, 1 3/8	5/16 x 5/32	4.50
	1 7/16, 1 1/2, 1 9/16, 1 5/8, 1 11/16, 1 3/4	3/8 x 3/16	4.20
	1 13/16, 1 7/8, 1 15/16, 2, 2 1/16, 2 3/16, 2 1/4	1/2 x 1/4	3.00
	2 5/16, 2 3/8, 2 7/16, 2 1/2	5/8 x 3/16*	2.50
3020	13/16	3/16 x 3/32	5.30
	15/16, 1, 1 1/8, 1 3/16, 1 1/4	1/4 x 1/8	6.50
	1 5/16, 1 3/8	5/16 x 5/32	6.30
	1 7/16, 1 1/2, 1 9/16, 1 5/8, 1 11/16, 1 3/4	3/8 x 3/16	5.80
	1 7/8, 1 15/16, 2, 2 1/16, 2 1/8, 2 3/16, 2 1/4	1/2 x 1/4	5.30
	2 5/16, 2 3/8, 2 7/16, 2 1/2, 2 5/8, 2 11/16, 2 3/4	5/8 x 5/16	4.50
	2 7/8, 2 15/16, 3	3/4 x 1/4*	3.80
3030	13/16	3/16 x 3/32	7.60
	15/16, 1, 1 1/16, 1 1/8, 1 3/16, 1 1/4	1/4 x 1/8	9.20
	1 5/16, 1 3/8	5/16 x 5/32	8.90
	1 7/16, 1 1/2, 1 9/16, 1 5/8, 1 11/16, 1 3/4	3/8 x 3/16	8.60
	1 13/16, 1 7/8, 1 15/16, 2, 2 1/16	1/2 x 1/4	7.60
	2 1/8, 2 3/16, 2 1/4	1/2 x 1/4	7.60
	2 5/16, 2 3/8, 2 7/16, 2 1/2	5/8 x 5/16	6.20
	2 5/8, 2 11/16, 2 3/4	5/8 x 5/16	6.20
	2 7/8, 2 15/16, 3	3/4 x 1/4*	5.00
3535	1 3/16, 1 1/4	1/4 x 1/8	14.00
&	1 3/8	5/16 x 5/32	14.00
**3535-BSW	1 7/16, 1 1/2, 1 5/8, 1 11/16, 1 3/4	3/8 x 3/16	14.00
	1 7/8, 1 15/16, 2, 2 1/8, 2 3/16, 2 1/4	1/2 x 1/4	13.00
	2 5/16, 2 3/8, 2 7/16, 2 1/2, 2 5/8, 2 11/16, 2 3/4	5/8 x 5/16	12.00
	2 7/8, 2 15/16, 3, 3 1/8, 3 3/16, 3 1/4	3/4 x 3/8	10.00
	3 5/16, 3 3/8, 3 7/16, 3 1/2	7/8 x 1/4*	8.50
4040	1 7/16, 1 1/2, 1 5/8, 1 11/16, 1 3/4	3/8 x 3/16	22.00
	1 7/8, 1 15/16, 2, 2 1/8, 2 3/16, 2 1/4	1/2 x 1/4	22.00
	2 3/8, 2 7/16, 2 1/2, 2 5/8, 2 11/16, 2 3/4	5/8 x 5/16	22.00
	2 7/8, 2 15/16, 3, 3 1/8, 3 3/16, 3 1/4	3/4 x 3/8	17.00
	3 3/8, 3 7/16, 3 1/2, 3 11/16, 3 3/4	7/8 x 7/16	15.00
	3 7/8, 3 15/16, 4	1 x 1/4*	12.50
4545	1 15/16, 2, 2 3/16	1/2 x 1/4	30.00
	2 3/8, 2 7/16, 2 5/8, 2 3/4	5/8 x 5/16	30.00
	2 7/8, 2 15/16, 3, 3 1/8, 3 3/16, 3 1/4	3/4 x 3/8	30.00
	3 3/8, 3 7/16, 3 1/2, 3 5/8, 3 3/4	7/8 x 7/16	22.00
	3 7/8, 3 15/16, 4, 4 1/8, 4 3/16, 4 1/4	1 x 1/2	18.00
	4 3/8, 4 7/16, 4 1/2	1 x 1/4*	16.00
5050	2 7/16	5/8 x 5/16	38.00
	2 15/16	3/4 x 3/8	38.00
	3 3/8, 3 7/16, 3 5/8	7/8 x 7/16	38.00
	3 7/8, 3 15/16, 4, 4 1/4, 4 3/8, 4 7/16, 4 1/2	1 x 1/2	27.00
	4 7/8, 4 15/16, 5	1 1/4 x 7/16*	21.50

All sizes made out of Cast Iron.

** These bushings are only to be used with metric sheaves.

* Shallow Keyseat - Keystock supplied with bushing † Oversize Key
Note: A rectangular key is supplied with bushings that have shallow keyseats. This key will fit the standard depth keyseat on the shaft and the shallow keyseat on the bushing. Ordering Example: (1008-1/2) or (3535-BSW-2.15/16)

TB Bushings

Bushing	Bore Range-mm	Keyway-mm	Wt.
1008	14, 16	5 x 2.3	.27
	18, 19, 20, 22	6 x 2.8	.27
	24, 25	8 x 2.3	.27
1108	14, 16	5 x 2.3	.33
	18, 19, 20, 22	6 x 2.8	.33
	24, 25	8 x 3.3	.33
	28	8 x 2.3	.33
1210	14, 16	5 x 2.3	.61
	18, 19, 20, 22	6 x 2.8	.61
	24, 25, 28, 30	8 x 3.3	.61
	32	10 x 3.3	.61
1215	14, 16	5 x 2.3	.80
	18, 19, 20, 22	6 x 2.8	.80
	24, 25, 28, 30	8 x 3.3	.80
	32	10 x 3.3	.80
1310	14, 16	5 x 2.3	.70
	18, 19, 20, 22	6 x 2.8	.70
	24, 25, 28, 30	8 x 3.3	.70
	32, 35	10 x 3.3	.70
1610	14, 16	5 x 2.3	.90
	18, 19, 20, 22	6 x 2.8	.90
	24, 25, 28, 30	8 x 3.3	.90
	32, 35, 38	10 x 3.3	.90
	40	12 x 3.3	.90
	42	12 x 2.8	.90
1615	14, 16	5 x 2.3	1.20
	18, 19, 20, 22	6 x 2.8	1.20
	24, 25, 28, 30	8 x 3.3	1.20
	32, 35, 38	10 x 3.3	1.20
	40	12 x 3.3	1.20
	42	12 x 2.8	1.20
2012	18, 19, 20, 22	6 x 2.8	1.70
	24, 25, 28, 30	8 x 3.3	1.70
	32, 35, 38	10 x 3.3	1.70
	40, 42	12 x 3.3	1.70
	45, 48, 50	14 x 3.8	1.70
2517 & **2517-BSW	20, 22	6 x 2.8	3.50
	24, 25, 28, 30	8 x 3.3	3.50
	32, 35, 38	10 x 3.3	3.50
	40, 42,	12 x 3.3	3.50
	45, 48, 50	14 x 3.8	3.50
	55	16 x 4.3	2.05
3020 and 3030	25, 28, 30	8 x 3.3	6.50
	32, 35, 38	10 x 3.3	6.50
	40, 42	12 x 3.3	6.50
	45, 48, 50	14 x 3.8	6.50
	55	16 x 4.3	6.50
	60, 65	18 x 4.4	4.50
3535 & **3535-BSW	70, 75	20 x 4.9	3.50
	35, 38	10 x 3.3	14.00
	40, 42	12 x 3.3	14.00
	45, 48, 50	14 x 3.8	14.00
	55	16 x 4.3	14.00
	60, 65	18 x 4.4	14.00
	70, 75	20 x 4.9	14.00
	80, 85	22 x 5.4	14.00
4040	90	25 x 5.4	14.00
	40, 42	12 x 3.3	22.00
	45, 48, 50	14 x 3.8	22.00
	55	16 x 4.3	22.00
	60, 65	18 x 4.4	22.00
	70, 75	20 x 4.9	22.00
	80, 85	22 x 5.4	22.00
	90, 95	25 x 5.4	22.00
4545	100	28 x 6.4	22.00
	55	16 x 4.3	30.00
	60, 65	18 x 4.4	30.00
	70, 75	20 x 4.9	30.00
	80, 85	22 x 5.4	30.00
	90, 95	25 x 5.4	30.00
5050	100, 105, 110	28 x 6.4	38.00
	60, 65	18 x 4.4	38.00
	70, 75	20 x 4.9	38.00
	80, 85	22 x 5.4	38.00
	90, 95	25 x 5.4	38.00
	115, 120, 125	32 x 7.4	38.00

** These bushings are only to be used with metric sheaves

TB BUSHINGS INSTALLATION

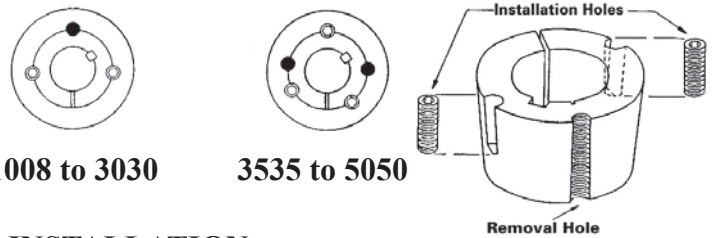

1008 to 3030

3535 to 5050

INSTALLATION

1. Properly clean shaft, bore and taper surface of bushing. Remove or degrease any oil, paint or dirt.
2. Install the bushing into the pulley hub. Be sure to match the hole pattern, not the threaded holes. Match the half threaded holes with the half straight holes (a complete hole will be threaded on one side only.)
3. Lightly oil the set screws(1008 to 3030) or the cap screws (3525 to 5050) , be sure to oil under the cap screw head. Install the screws into the holes that are threaded on the hub side (shown as  in diagram). DO NOT LUBRICATE THE BUSHING TAPER OR BORE. BREAKAGE OF PRODUCT MAY OCCUR.
4. Fit the pulley with the bushing onto the shaft and locate in the proper location. Install key into the keyway of the shaft and bushing.
5. Tighten screws alternately and gradually in accordance with the torques listed on the Recommended Wrench Torque chart.
6. Using a hammer with a block or sleeve (do not hit bushing directly with hammer) tap on large end of the bushing and re-tighten screws per the appropriate Wrench Torque Values.
7. Fill screw heads with grease to eliminate dirt build up.

REMOVAL

1. Remove all screws and lightly oil the point and threads. Oil under cap screws if used.
2. Install screws into the holes that are threaded only on the bushing side (shown as  in diagram).
3. Tighten screws uniformly and alternately until the bushing is loose from in the hub and pulley is free from the shaft. Tap on small end of bushing to assist removal if it does not loosen. Note: One screw is not used for removal.

Recommended Wrench Torque			
Bushing #	Lb-In	Nm ²	Set Screw Hex Size
1008,1108	53	6	1/8"
1210, 1215	176	20	3/16"
1310	176	20	3/16"
1610, 1615	176	20	3/16"
2012	273	31	7/32"
2517-BSW	422	48	6mm
2525	422	48	1/4"
3020, 3030	790	90	5/16"
3535-BSW	986	112	10mm
4040	1,670	190	1/2"
4545	2,380	270	5/8"
5050	3,080	350	3/4"

Ordering Example: (1008-14MM) or (3535-BSW-50MM)

DOUBLE SPLIT TAPER BUSHINGS

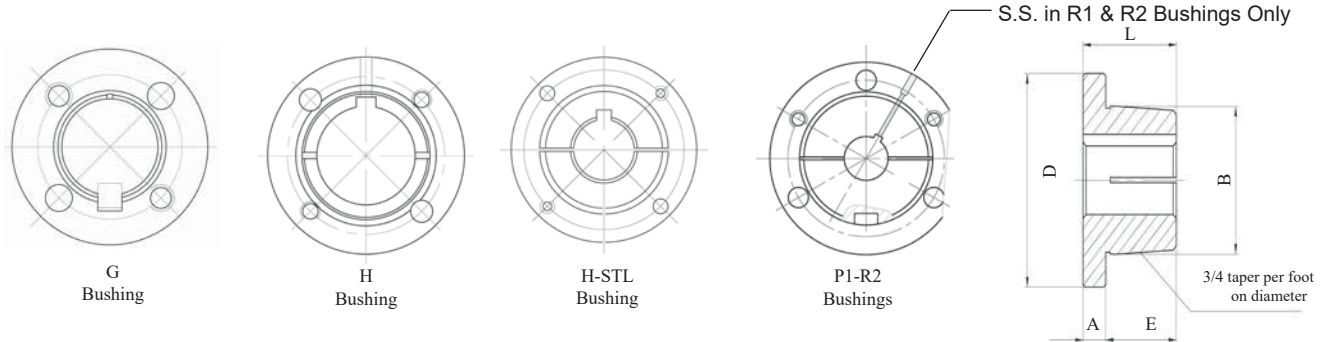

Double Split Taper Bushing - Dimensions (inches)						I d bolD Required	Cap Screws Grade 5 Min.	
Bushing	A	B	D	E	L		Qty.	Size
G	1/4	1.172	2	3/4	1	1 9/16	2	1/4 x 5/8
H*	11/32	1 5/8	2 1/2	1	1 11/32	2	2	1/4 x 1
H-STL**	1/4	1 5/8	2 1/2	1	1 1/4	2	2	1/4 x 3/4
P1	13/32	1 15/16	3	1 17/32	1 15/16	2 7/16	3	5/16 x 1
P2	13/32	1 15/16	3	2 17/32	2 15/16	2 7/16	3	5/16 x 1
Q1	17/32	2 7/8	4 1/8	1 31/32	2 1/2	3 3/8	3	3/8 x 1 1/4
Q2	17/32	2 7/8	4 1/8	2 31/32	3 1/2	3 3/8	3	3/8 x 1 1/4
R1	5/8	4	5 3/8	2 1/4	2 7/8	4 5/8	3	3/8 x 1 3/4
R2	5/8	4	5 3/8	4 1/4	4 7/8	4 5/8	3	3/8 x 1 3/4

*Standard H bushings are made out of powdered metal and include a set screw over the keyway.

**STL H bushings are optional and are made out of steel. These do not have a set screw.

Bushing	Bore Range-inch	Wt.	Key Seat-inch
G	3/8, 7/16, 1/2, 9/16..... 5/8, 11/16, 3/4, 13/16, 7/8 15/16, 1.....	0.40 0.40 0.40 0.40	None 1/8 x 1/16 3/16 x 3/32 1/4 x 1/16 *
H	3/8**, 7/16** 1/2**, 9/16** 5/8, 11/16, 3/4, 13/16, 7/8 15/16, 1, 1 1/16, 1 1/8, 1 3/16, 1 1/4 1 5/16, 1 3/8 1 3/8†, 1 7/16**, 1 1/2**	0.90 0.90 0.90 0.90 0.90 0.90	3/32 x 3/64 1/8 x 1/16 3/16 x 3/32 1/4 x 1/8 5/16 x 1/16 * 3/8 x 1/16 *
P1	1/2, 9/16, 5/8, 21/32, 11/16, 3/4, 25/32, 13/16, 7/8 15/16, 31/32, 1, 1 1/16, 1 1/8, 1 3/16, 1 1/4 1 5/16, 1 3/8 1 7/16, 1 1/2, 1 5/8, 1 11/16, 1 3/4	1.70 1.70 1.70 1.70 1.70	1/8 x 1/16 3/16 x 3/32 1/4 x 1/8 5/16 x 5/32 3/8 x 3/16
P2	3/4, 13/16, 7/8 15/16, 1, 1 1/16, 1 1/8, 1 3/16, 1 1/4 1 5/16, 1 3/8 1 7/16, 1 1/2, 1 9/16, 1 5/8, 1 11/16	2.18 2.18 2.18 2.18	3/16 x 3/32 1/4 x 1/8 5/16 x 5/32 3/8 x 3/16
Q1	3/4, 13/16, 7/8 15/16, 1, 1 1/16, 1 1/8, 1 3/16, 1 1/4, 1 5/16, 1 3/8 1 7/16, 1 1/2, 1 9/16, 1 5/8, 1 11/16, 1 3/4 1 13/16, 1 7/8, 1 15/16, 2, 2 1/16, 2 1/8, 2 3/16, 2 1/4 2 5/16, 2 3/8, 2 7/16, 2 1/2.....	4.60 4.60 4.60 4.60 4.60 4.60	3/16 x 3/32 1/4 x 1/8 5/16 x 5/32 3/8 x 3/16 1/2 x 1/4 5/8 x 5/16

Bushing	Bore Range-inch	Wt.	Key Seat-inch
Q2	1, 1 1/16, 1 1/8, 1 3/16, 1 1/4 1 5/16, 1 3/8 1 7/16, 1 1/2, 1 9/16, 1 5/8, 1 11/16, 1 3/4 1 13/16, 1 7/8, 1 15/16, 2 2 1/16, 2 1/8, 2 3/16, 2 1/4..... 2 5/16, 2 3/8, 2 7/16, 2 1/2, 2 9/16,	5.80 5.80 5.80 5.80 5.80 5.80	1/4 x 1/8 5/16 x 5/32 3/8 x 3/16 1/2 x 1/4 1/2 x 1/4 5/8 x 5/16
R1	1 1/8, 1 3/16, 1 1/4 1 5/16, 1 3/8, 1 7/16 1 1/2, 1 9/16, 1 5/8, 1 11/16, 1 3/4 1 13/16, 1 7/8, 1 15/16, 2, 2 1/16, 2 1/8, 2 3/16, 2 1/4..... 2 5/16, 2 3/8, 2 7/16, 2 1/2..... 2 9/16, 2 5/8, 2 11/16, 2 3/4..... 2 13/16, 2 7/8, 2 15/16, 3, 3 1/8, 3 3/16, 3 1/4 3 3/8, 3 7/16, 3 1/2, 3 5/8, 3 3/4	9.95 9.95 9.95 9.95 9.95 9.95 9.95 9.95 9.95	1/4 x 1/8 5/16 x 5/32 3/8 x 3/16 3/8 x 3/16 1/2 x 1/4 5/8 x 5/16 5/8 x 5/16 3/4 x 3/8 7/8 x 7/16
R2	1 3/8 1 7/16, 1 1/2, 1 9/16, 1 5/8, 1 11/16, 1 3/4 1 13/16, 1 7/8, 1 15/16, 2, 2 1/16, 2 1/8, 2 3/16, 2 1/4 2 5/16, 2 3/8, 2 7/16, 2 1/2..... 2 9/16, 2 5/8, 2 11/16, 2 3/4 2 13/16, 2 7/8, 2 15/16, 3, 3 1/8, 3 3/16, 3 1/4 3 3/8, 3 7/16, 3 1/2.....	14.38 14.38 14.38 14.38 14.38 14.38 14.38	5/16 x 5/32 3/8 x 3/16 1/2 x 1/4 5/8 x 5/16 5/8 x 5/16 3/4 x 3/8 7/8 x 7/16

* Shallow Keyseat - Keystock supplied with bushing

** These H bushings are only available in steel.

† Oversize Key

Note: A rectangular key is supplied with bushings that have shallow keyseats. This key will fit the standard depth keyseat on the shaft and the shallow keyseat on the bushing.

Ordering Example: (P1-1) or (Q1-1.1/16) or (H1-1/16) or (H1-1/16-STL)

All sizes except H are made out of Ductile Iron.

DOUBLE SPLIT TAPER BUSHINGS

Bushing	Bore Range-mm	Key Seat-mm	Wt.
G	10, 11, 12,	No Key	0.4
	14,16,	5 x 2.3	0.4
	18, 19, 20, 22,	6 x 2.8	0.4
	24	8 x 2.2	0.4
	25	8 x 1.7	0.4
H	10**, 11**	No Key	0.9
	14**, 15**, 16, 17	5 x 2.3	0.9
	18, 19, 20, 22	6 x 2.8	0.9
	24, 25, 28, 30	8 x 3.3	0.9
	32**, 35**	10 x 3.3	0.9
P1	14, 15, 16,	5 x 2.3	1.7
	18, 19, 20, 22	6 x 2.8	1.7
	24, 25, 28, 30	8 x 3.3	1.7
	32, 35, 36, 38,	10 x 3.3	1.7
	39, 40, 42	12 x 3.3	1.7
Q1	18, 19, 20, 22	6 x 2.8	4.60
	24, 25, 28, 30	8 x 3.3	4.60
	32, 35, 36, 38,	10 x 3.3	4.60
	40, 42	12 x 3.3	4.60
	45, 48, 50	14 x 3.8	4.60
	55	16 x 4.3	4.60
	60, 65	18 x 4.4	4.60
R1	28, 30	8 x 3.3	9.95
	32, 35, 36, 38	10 x 3.3	9.95
	39, 40, 42	12 x 3.3	9.95
	45, 48, 50	14 x 3.8	9.95
	55	16 x 4.3	9.95
	60, 65	18 x 4.4	9.95
	70, 75	20 x 4.9	9.95
	80, 85	22 x 5.4	9.95
	90, 95	25 x 5.4	9.95
R2	35, 36, 38	10 x 3.3	14.38
	39, 40, 42	12 x 3.3	14.38
	45, 48, 50	14 x 3.8	14.38
	55	16 x 4.3	14.38
	60, 65	18 x 4.4	14.38
	70, 75	20 x 4.9	14.38
	80, 85,	22 x 5.4	14.38
	90	25 x 5.4	14.38

** These H bushings are only available in steel.

DOUBLE SPLIT TAPER BUSHINGS INSTALLATION INSTRUCTIONS



INSTALLATION

1. Properly clean shaft, bore and taper surfaces of bushing. Remove and degrease any excess oil, paint or dirt, this includes the cap screws. Caution: Excessive cap screw torque can cause sheave or bushing breakage. The use of lubricants can cause sheave breakage. **DO NOT USE LUBRICANTS OF ANY TYPE WITH THIS INSTALLATION.**
2. Install the bushing into the hub and match the unthreaded bushing holes with the threaded holes of the hub. Install the cap screws and lock washers through the unthreaded holes and into the threaded holes of the hub. Engage only a few threads by hand – Do not use a wrench.
3. Install key into the keyway of the shaft and fit assembly onto the shaft and locate in the proper location.
4. Tighten cap screws alternately and gradually. Tighten cap screws to the recommended Wrench Torque Value using a torque wrench.

REMOVAL

Remove cap screws and insert into the tapped holes in the bushing. Tighten them alternately and gradually until the bushing disengages from the hub.

Recommended Wrench Torque		
Bushing #	lb-in	lb-ft
G	95	8
H	95	8
P1	192	16
P2	192	16
Q1	348	29
Q2	348	29
R1	348	29
R2	348	29

Minimum Plain Bore Bushings



QD Style

Part#	Bore Size
JAMPB	1/2
SHMPB	1/2
SDSMPB	1/2
SDMPB	1/2
SKMPB	1/2
SFMPB	1/2
EMPB	7/8
FMPB	1
JMPB	1 1/2
MMPB	2
NMPB	2 7/16
WMPB	4



DST Style

Part#	Bore Size
GMPB	3/8
HMPB	3/8
P1MPB	1/2
P2MPB	3/4
Q1MPB	3/4
Q2MPB	1
R1MPB	1 1/8
R2MPB	1 3/8



TB Style

Part#	Bore Size	Keyway
1008MPB	1/2	1/8 x 1/16
1108MPB	1/2	1/8 x 1/16
1210MPB	1/2	1/8 x 1/16
1215MPB	1/2	1/8 x 1/16
1310MPB	1/2	1/8 x 1/16
1610MPB	1/2	1/8 x 1/16
1615MPB	1/2	1/8 x 1/16
2012MPB	1/2	1/8 x 1/16
2517MPB	1/2	1/8 x 1/16
2525MPB	7/8	3/16 x 3/32
3020MPB	15/16	1/4 x 1/8
3030MPB	15/16	1/4 x 1/8
3535MPB	1 3/16	1/4 x 1/8
4040MPB	1 7/16	3/8 x 3/16
4545MPB	1 15/16	1/2 x 1/4
5050MPB	2 7/16	5/8 x 5/16

Replacement Bolt Kits for Bushings			
Bushing	Bolt Kit P/N	Bushing	Bolt Kit P/N
1008	1008BK	P1	P1BK
1108	1108BK	P2	P2BK
1210	1210BK	Q1	Q1BK
1215	1215BK	Q2	Q2BK
1310	1310BK	R1	R1BK
1610	1610BK	R2	R2BK
1615	1615BK	JA	JABK
2012	2012BK	SH	SHBK
2517	2517BK	SDS	SDSBK
2525	2525BK	SD	SDBK
3020	3020BK	SK	SKBK
3030	3030BK	SF	SFBK
3535	3535BK	E	EBK
4040	4040BK	F	FBK
4545	4545BK	J	JBK
5050	5050BK	M	MBK
G	GBK	N	NBK
H	HBK	P	PBK

Note: Each kit contains bolts and washers for one bushing.

Note: MPB bushings are unsplit and unless noted have no keyway for ease of machining. Bushings must be saw cut prior to use.

Weld-On Hubs

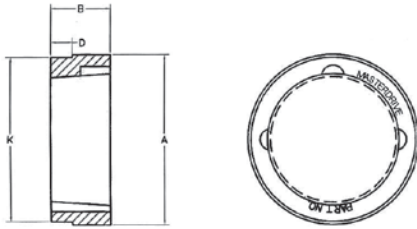

S Style TB Bushing Weld-On Hubs

S Style Weld-On Hub Dimensions						Thread Dia.
HUBS	Bushing	A	B	D	K	
S16-4	1610	3.000	1.000	0.275	2.875	3/8-16
S16-6	1610	3.000	1.000	0.450	2.875	3/8-16
S20-6	2012	3.563	1.250	0.450	3.438	7/16-14
S20-8	2012	3.563	1.250	0.570	3.438	7/16-14
S25-6	2517	4.250	1.750	0.450	4.125	1/2-13
S25-8	2517	4.250	1.750	0.565	4.125	1/2-13
S25-10	2517	4.250	1.750	0.685	4.125	1/2-13
S25-16	2517	4.250	1.750	1.090	4.125	1/2-13
S30-10	3020	5.250	2.000	0.675	5.125	5/8-11
S30-16	3020	5.250	2.000	1.090	5.125	5/8-11
S35	3535	6.500	3.500	1.160	6.375	1/2-13

TB BUSHING WELD-ON HUBS

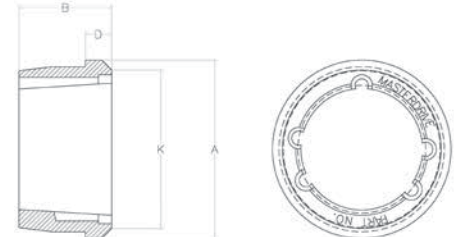

W Style TB Bushing Weld-On Hubs

W Style Weld-On Hub Dimensions						Thread Dia.
HUBS	Bushing	A	B	D	K	
W12	1215	2.875	1.500	0.625	2.500	3/8-16
W16	1615	3.250	1.500	0.625	2.875	3/8-16
W25	2517	4.875	1.750	0.750	4.375	1/2-13
WA30	3030	5.500	3.000	0.750	5.125	5/8-11
WA35	3535	6.750	3.500	1.000	6.250	1/2-13
WA40	4040	7.750	4.000	1.000	7.250	5/8-11
WA45	4545	8.750	4.500	1.000	8.000	3/4-10
WA50	5050	9.500	5.000	1.000	8.750	7/8-9

QD BUSHING WELD-ON HUBS

QD Weld-On Hub Dimensions					Thread Dia.
HUBS	D	L	BC	Type	
JA-A	2.250	0.563	1.656	1	10-24
SH-A	3.000	0.813	2.250	1	1/4-20
SDS-A	3.500	0.750	2.688	1	1/4-20
SK-A	4.375	1.250	3.313	1	5/16-18
SF-A	5.000	1.250	3.875	1	3/8-16
E-A	6.250	1.625	5.000	1	1/2-13
F-A	7.000	2.500	5.625	1	9/16-12
J-A	7.750	3.188	6.250	1	5/8-11

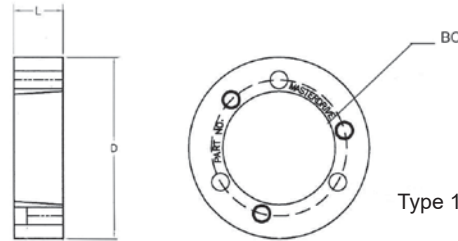

Type 1

QD Weld-On Hub Dimensions					Thread Dia.
HUBS	D	L	P	Type	
M-A	9.50	5.188	9.250	2	3/4-10
N-A	10.50	6.250	10.250	2	7/8-9

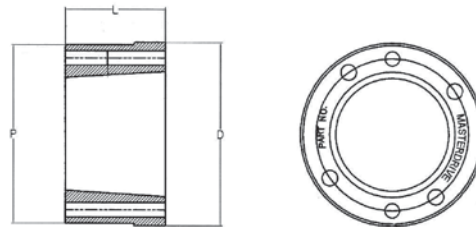

Type 2

Can only be mounted from one direction.

DST BUSHING WELD-ON HUBS

DST Style Weld-On Hub Dimensions					Thread Dia.
HUBS	O.D	A	C	X	
HG1	2.00	0.174	1.875	0.625	1/4-20
HH1	2.50	0.174	2.375	0.875	1/4-20
HCH1	2.50	0.625	2.375	0.875	1/4-20
HP1	3.00	0.292	2.875	1.313	5/16-18
HCP1	3.00	1.000	2.875	1.313	5/16-18
HP2	3.00	1.100	2.875	2.313	5/16-18
HQ1	4.50	0.709	4.375	1.750	3/8-16
HCQ1	4.50	1.250	4.375	1.750	3/8-16
HQ2	4.50	1.606	4.375	2.750	3/8-16
HR1	5.75	0.709	5.625	2.000	3/8-16
HR2	5.75	1.606	5.625	4.000	3/8-16

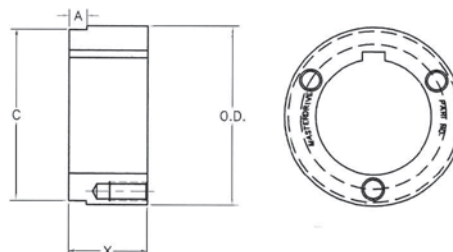

All sizes made out of **Low Carbon Steel**.

BCS Couplings

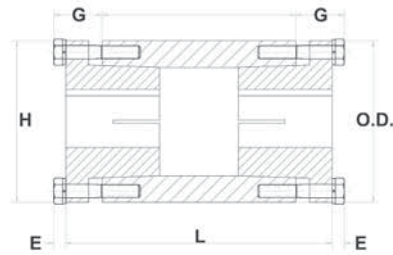

Type BCS-SF, BCS-SK & BCS-SD

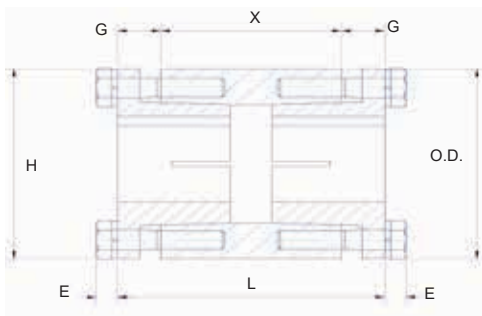

Type BCS-H

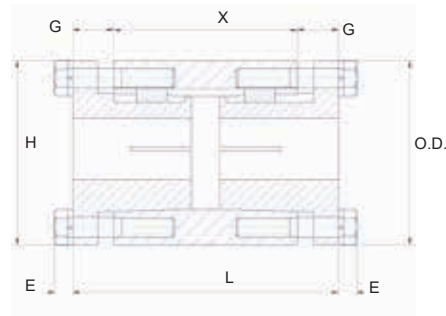

Type BCS-P1 & BCS-Q1

Part Number	Bushing		Dimensions						T*	Wt. Lbs.
	Size	Bore Range	O.D.	L	H	G	X	E		
BCS-SF	SF	1/2 - 2-15/16	4-5/8	6-7/16	4-5/8	7/8	3-3/4	1/2	11000	9.95
BCS-SK	SK	1/2 - 2-5/8	3-7/8	5-5/16	3-7/8	3/4	3-3/4	11/32	7000	6.20
BCS-SD	SD	1/2 - 2	3-1/8	5-5/32	3-1/8	11/16	3-3/4	1/4	5000	4.35
BCS-H	H	3/8 - 1-1/2	2-1/2	3	2-1/2	1/2	2	1/4	1700	1.70
BCS-P1	P1	1/2 - 1-3/4	3	4-11/32	3	11/16	3	3/8	5660	3.60
BCS-Q1	Q1	3/4 - 2-11/16	4-3/8	5-1/2	4-1/2	3/4	4	7/16	14600	9.95

T*= Maximum Recommended Torque in inch pounds for Normal Service. These ratings should be reduced by 50% for Heavy Duty Service.

Note: Two Bushings will need to be ordered per coupling.

All sizes made out of **Steel**.

JAW COUPLINGS



Hub Bore inch	Set Screw Size	Key Way- inch
L035 1/8, 3/16, 1/4, 5/16, 3/8	6-32	NONE
L050 1/4, 5/16, 3/8, 7/16	1/4-20	NONE
1/2, 9/16	1/4-20	1/8 x 1/16
5/8	1/4-20	3/16 x 3/32
L070 1/4, 5/16, 3/8, 7/16, 1/2	1/4-20	NONE
7/16, 1/2, 9/16	1/4-20	1/8 x 1/16
5/8, 11/16, 3/4	1/4-20	3/16 x 3/32
L075 1/4, 5/16, 3/8, 7/16, 1/2	1/4-20	NONE
7/16, 1/2, 9/16	1/4-20	1/8 x 1/16
5/8, 11/16, 3/4, 13/16, 7/8	1/4-20	3/16 x 3/32
L090 1/4, 5/16, 3/8, 7/16, 1/2	5/16-18	NONE
7/16, 1/2, 9/16	5/16-18	1/8 x 1/16
5/8, 11/16, 3/4, 13/16, 7/8	5/16-18	3/16 x 3/32
15/16, 1, 1 1/8	5/16-18	1/4 x 1/8
L095 7/16, 1/2	5/16-18	NONE
1/2, 9/16	5/16-18	1/8 x 1/16
5/8, 11/16, 3/4, 13/16, 7/8,	5/16-18	3/16 x 3/32
15/16, 1, 1 1/16, 1 1/8	5/16-18	1/4 x 1/8
L099 7/16, 1/2	5/16-18	NONE
7/16, 1/2, 9/16	5/16-18	1/8 x 1/16
5/8, 11/16, 3/4, 13/16, 7/8	5/16-18	3/16 x 3/32
15/16, 1, 1 1/16, 1 1/8, 1 3/16	5/16-18	1/4 x 1/8
L100 7/16,	5/16-18	NONE
1/2, 9/16	5/16-18	1/8 x 1/16
5/8, 11/16, 3/4, 13/16, 7/8	5/16-18	3/16 x 3/32
15/16, 1, 1 1/16, 1 1/8, 1 3/16, 1 1/4	5/16-18	1/4 x 1/8
1 5/16, 1 3/8	5/16-18	5/16 x 5/32
1 7/16	5/16-18	3/8 x 3/16

Hub Bore inch	Set Screw Size	Key Way- inch
L110 5/8, 11/16, 3/4, 13/16, 7/8	3/8-16	3/16 x 3/32
15/16, 1, 1 1/16, 1 1/8, 1 3/16, 1 1/4	3/8-16	1/4 x 1/8
1 5/16, 1 3/8	3/8-16	5/16 x 5/32
1 7/16, 1 1/2, 1 9/16, 1 5/8, 1 3/4	3/8-16	3/8 x 3/16
1 7/8	3/8-16	1/2 x 1/4
L150 1/2,	3/8-16	1/8 x 1/16
5/8, 3/4, 13/16, 7/8	3/8-16	3/16 x 3/32
15/16, 1, 1 1/16, 1 1/8, 1 3/16, 1 1/4	3/8-16	1/4 x 1/8
1 5/16, 1 3/8	3/8-16	5/16 x 5/32
1 7/16, 1 1/2, 1 9/16, 1 5/8, 1 11/16, 1 3/4 ...	3/8-16	3/8 x 3/16
1 7/8	3/8-16	1/2 x 1/4
L190 1/2,	1/2-13	1/8 x 1/16
3/4, 13/16, 7/8	1/2-13	3/16 x 3/32
15/16, 1, 1 1/16, 1 1/8, 1 3/16, 1 1/4	1/2-13	1/4 x 1/8
1 5/16, 1 3/8	1/2-13	5/16 x 5/32
1 7/16, 1 1/2, 1 9/16, 1 5/8, 1 11/16, 1 3/4 ...	1/2-13	3/8 x 3/16
1 7/8, 1 15/16, 2, 2 1/16, 2 1/8	1/2-13	1/2 x 1/4
L225 3/4, 13/16, 7/8	1/2-13	3/16 x 3/32
15/16, 1, 1 1/16, 1 1/8, 1 3/16, 1 1/4	1/2-13	1/4 x 1/8
1 5/16, 1 3/8	1/2-13	5/16 x 5/32
1 7/16, 1 1/2, 1 9/16, 1 5/8, 1 11/16, 1 3/4 ...	1/2-13	3/8 x 3/16
1 7/8, 1 15/16, 2, 2 1/16, 2 1/8, 2 3/16, 2 1/4	1/2-13	1/2 x 1/4
2 3/8, 2 7/16, 2 1/2, 2 5/8	1/2-13	5/8 x 5/16

Hub	Bore MM	Set Screw Size	Keway - MM
L050	10, 11, 12	1/4-20	NONE
L070	11, 12	1/4-20	NONE
	14, 15, 16	1/4-20	5 x 2.3
	19	1/4-20	6 x 2.8
L075	12	1/4-20	NONE
	14, 15, 16	1/4-20	5 x 2.3
	19, 20, 22	1/4-20	6 x 2.8
L090	17	5/16-18	5 x 2.3
	19, 20, 22	5/16-18	6 x 2.8
	24	5/16-18	8 x 3.3
L095	17	5/16-18	5 x 2.3
	19, 20, 22	5/16-18	6 x 2.8
	24, 25, 28	5/16-18	8 x 3.3
L099	22	5/16-18	6 x 2.8
	24, 25, 28	5/16-18	8 x 3.3
L100	24, 25, 28, 30	5/16-18	8 x 3.3
	35	5/16-18	10 x 3.3
L110	24, 25, 28, 30	3/8-16	8 x 3.3
	32, 38	3/8-16	10 x 3.3
	42	3/8-16	12 x 3.3
L150	32, 38	3/8-16	10 x 3.3
	42	3/8-16	12 x 3.3
	45, 48	3/8-16	14 x 3.8
L190	42	1/2-13	12 x 3.3
	55	1/2-13	16 x 4.3
L225	48	1/2-13	14 x 3.8
	55	1/2-13	16 x 4.3

Sizes L035-L095 are made of powdered metal.
 Sizes L100-L225 are made of cast iron.

JAW COUPLINGS

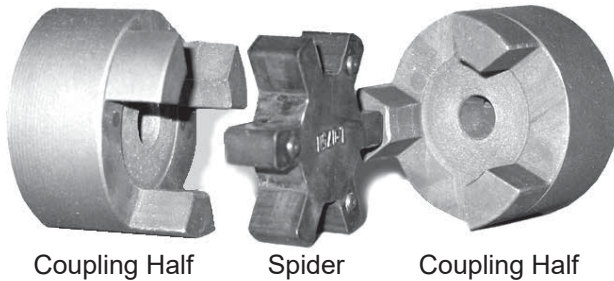

Coupling Half Spider Coupling Half

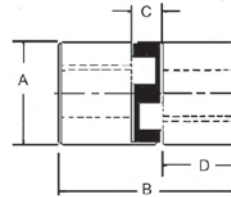

Type 1

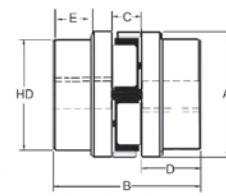

Type 2

Jaw Coupling - Dimensions (inches)

Coupling	Type	Hub Dia	Overall Length	Distance Between Flanges	Length Thru Bore	E	HD	Avg. Wt. Lbs	Set Screw Thread Size	Set Screw Qty.
		A	B	C	D					
L035	1	0.625	0.813	0.281	0.266	-	-	0.10	#6-32UNCX1/8"	1
L050	1	1.063	1.721	0.470	0.625	-	-	0.29	1/4"-20UNCX3/16"	1
L070	1	1.375	2.000	0.500	0.770	-	-	0.56	1/4"-20UNCX1/4"	2
L075	1	1.750	2.126	0.480	0.820	-	-	0.95	1/4"-20UNCX3/8"	2
L090	1	2.125	2.146	0.490	0.841	-	-	1.45	1/4"-20UNCX3/8"	2
L095	1	2.125	2.520	0.455	1.020	-	-	1.70	5/16"-18UNCX3/8"	2
L099	1	2.531	2.835	0.650	1.071	-	-	2.50	5/16"-18UNCX3/8"	2
L100	1	2.531	3.459	0.660	1.368	-	-	3.40	5/16"-18UNCX3/8"	2
L110	1	3.313	4.252	0.843	1.706	-	-	6.40	3/8"-16UNCX5/16"	2
L150	1	3.750	4.500	0.940	1.771	-	-	8.90	3/8"-16UNCX1/2"	2
L190	2	4.500	5.250	0.875	2.134	1.340	4	8.75	1/2"-13UNCX1/2"	2
L225	2	5.000	6.142	0.942	2.500	1.733	4.25	12.25	1/2"-13UNCX1/2"	2



Spiders - Buna-N (Rubber), Hytrel, Urethane, Bronze

Buna-N (Black)		Hytrel (White)		Urethane (Orange)		Bronze	
Part#	Wt.	Part#	Wt.	Part#	Wt.	Part#	Wt.
L035N	.01						
L050N	.01	L050H	.01	L050U	.01	L050B	.01
L070N	.01	L070H	.04	L070U	.01	L070B	.01
L075N	.01	L075H	.04	L075U	.02	L075B	.02
L090N	.01	L090H	.04	L090U	.02	L090B	.02
L095N	.01	L095H	.04	L095U	.02	L095B	.02
L099N	.01	L099H	.06	L099U	.02	L099B	.02
L100N	.01	L100H	.06	L100U	.02	L100B	.02
L110N	.16	L110H	.20	L110U	.20	L110B	.20
L150N	.30	L150H	.30	L150U	.30	L150B	.30
L190N	.40	L190H	.40	L190U	.40	L190B	.40
L225N	.40	L225H	.40	L225U	.40	L225B	.40

Note: All inserts have a closed center except Bronze inserts which have an open center.

JAW COUPLING SELECTION

Example: A 10 HP hydraulic motor running a centrifugal pump 16 hours a day. Motor shaft is 1-3/8” and pump shaft is 1-1/2”

<p>Step #1: Determine the prime mover class. (See the Prime Mover Classifications chart)</p>	<p>Hydraulic Motors fall under class A</p>
<p>Step #2: Determine the load characteristics and the service factor. (See the Load Characteristics and Service Factors chart)</p>	<p>Centrifugal Pumps are uniformly loaded. The prime mover class of the motor is A and the motor is running over 8 hours per day. The service factor would be 1.5.</p>
<p>Step #3: Calculate Design Horsepower or Design Torque.</p> <ul style="list-style-type: none"> • If Prime Mover is a 1200, 1800, or 3600 RPM motor: Design HP = Prime Mover HP x Service Factor. (See the Torque-Horsepower Ratings charts & reference the corresponding motor RPM column) • If Prime Mover is not one of the speeds above: Design HP @ 100 RPM = (Prime Mover HP x Service Factor x 100) / Coupling RPM. (See chart on pages 2-3 and reference HP @ 100 RPM column) • If using Prime Mover Torque: Design HP = Prime Mover Torque x Service Factor. (See chart on page 2 and reference Torque column) 	<p>Prime Mover is an 1800 RPM motor. Design HP = 10 x 1.5 = 15. Looking at the Torque-Horsepower Ratings charts the options are: L110 with Buna insert, L095 with Hytrel insert or L110 with urethane insert.</p>
<p>Step #4: Check the Torque-Horsepower Ratings charts for max. bore of coupling.</p>	<p>1-1/2” shaft on the pump is too large for L095 or L100 couplings. Use L110 with Buna insert. For complete coupling order: 1 - L110-1.3/8 1 - L110-1.1/2 & 1- L110N</p>

Prime Mover Classifications

Prime Mover	Class
Electric Motors (Standard duty, Hydraulic Motors, Turbines)	A
Gasoline or Steam Engines (4 or more cylinders)	B
Diesel or Gas Engines, High Torque Electric Motors	C

Load Characteristics and Service Factors

Typical Applications	Load	Characteristics	Prime Mover Class		
			A	B	C
Agitators (pure liquids), Blowers (centrifugal, Can and Bottle Filling Machines, Conveyors - uniformly loaded or fed (belt, chain, screw), Fans (centrifugal), Generators (uniform load), Pumps (centrifugal), Screens (air washing, water) Stokers (uniform load), Woodworking Machines (planers, routers, saws)	Uniform	Even loads - no shock - non reversing - infrequent starts (up to 10 per day) - low starting torques - Up to 8 hours per day - Over 8 hours per day	1.0 1.5	1.5 2.0	2.0 2.5
Beaters, Blowers (lobe, vane), Compressors (centrifugal, rotary), Conveyors - non uniformly loaded or fed (belt, bucket, chain, screw), Dredge Pumps, Fans (forced draft, propeller), Kilns, Paper Mills (calendars, converting machines, conveyors, dryers, mixers, winders), Printing Presses, Pumps (gear, rotary), Shredders, Textile Machinery (dryers, dyers)	Moderate shock	Uneven loads - moderate shock. Infrequent reversing-moderate torques - Up to 8 hours per day - Over 8 hours per day	1.5 2.0	2.0 2.5	2.5 3.0
Cranes (bridge, hoist, trolley), Fans (cooling tower), Generators (welding), Hammer Mills, Mills (ball, pebble, rolling, tube, tumbling), Pumps (oil well), Wire Drawing Machines	Heavy shock	Uneven loads - heavy shock - frequent starts and stops - high starting torques - high inertia peak loads - Up to 8 hours per day - Over 8 hours per day	2.0 2.5	2.5 3.0	3.0 3.5

Torque - Horsepower Ratings

Couplings using Buna-N (N) Inserts

Part No.	Max Bore	Max RPM	Torque In. Lbs.	HP per 100 RPM	HP/Speeds (RPM)		
					1200	1800	3600
L035	3/8	31000	3.5	0.006	0.07	0.10	0.20
L050	5/8	18000	26.3	0.042	0.50	0.75	1.50
L070	3/4	14000	43.2	0.069	0.82	1.23	2.47
L075	7/8	11000	90.0	0.143	1.71	2.57	5.14
L090	1	9000	144.0	0.228	2.74	4.11	8.23
L095	1-1/8	9000	194.0	0.308	3.69	5.54	11.08
L099	1-3/16	7000	318.0	0.505	6.05	9.08	18.16
L100	1-7/16	7000	417.0	0.662	7.94	11.91	23.82
L110	1-7/8	5000	792.0	1.257	15.08	22.62	45.24
L150	1-7/8	5000	1240.0	1.967	23.61	35.41	70.83
L190	2-1/8	5000	1726.0	2.739	32.86	49.29	98.59
L225	2-5/8	4600	2340.0	3.713	44.55	66.83	133.66

Couplings using Hytrel (H) Inserts

Part No.	Max Bore	Max RPM	Torque In. Lbs.	HP per 100 RPM	HP/Speeds (RPM)		
					1200	1800	3600
L035	3/8	31000	-	-	-	-	-
L050	5/8	18000	50.0	0.079	0.95	1.43	2.86
L070	3/4	14000	114	0.181	2.17	3.26	6.51
L075	7/8	11000	227	0.360	4.32	6.48	12.97
L090	1	9000	401	0.636	7.64	11.45	22.91
L095	1-1/8	9000	561	0.890	10.68	16.02	32.04
L099	1-3/16	7000	792	1.257	15.08	22.62	45.24
L100	1-7/16	7000	1134	1.799	21.59	32.39	64.77
L110	1-7/8	5000	2268	3.599	43.18	64.77	129.55
L150	1-7/8	5000	3708	5.883	70.60	105.90	211.80
L190	2-1/8	5000	4680	7.426	89.11	133.66	267.32
L225	2-5/8	4600	6228	9.882	118.58	177.87	355.74

Couplings using Urethane (U) Inserts

Part No.	Max Bore	Max RPM	Torque In. Lbs.	HP per 100 RPM	HP/Speeds (RPM)		
					1200	1800	3600
L035	3/8	31000	-	-	-	-	-
L050	5/8	18000	39.4	0.063	0.75	1.12	2.25
L070	3/4	14000	64.8	0.103	1.23	1.84	3.70
L075	7/8	11000	135	0.214	2.56	3.85	7.71
L090	1	9000	216	0.342	4.11	6.16	12.34
L095	1-1/8	9000	294	0.462	5.53	8.31	16.62
L099	1-3/16	7000	477	0.757	9.07	13.62	27.24
L100	1-7/16	7000	626	0.993	11.91	17.86	35.73
L110	1-7/8	5000	1188	1.885	22.62	33.93	67.86
L150	1-7/8	5000	1860	2.950	35.41	53.11	106.24
L190	2-1/8	5000	2589	4.108	49.29	73.93	147.88
L225	2-5/8	4600	3510	5.569	66.82	100.24	200.49

Torque - Horsepower Ratings

Couplings using Bronze (B) Inserts

Part No.	Max Bore	Max RPM	Torque In. Lbs.	HP per 100 RPM	HP/Speeds (RPM)		
					1200	1800	3600
L035	3/8	250	-	-	-	-	-
L050	5/8	250	50.0	0.079	0.95	1.43	2.86
L070	3/4	250	114	0.181	2.17	3.26	6.51
L075	7/8	250	227	0.360	4.32	6.48	12.97
L090	1	250	401	0.636	7.64	11.45	22.91
L095	1-1/8	250	561	0.890	10.68	16.02	32.04
L099	1-3/16	250	792	1.257	15.08	22.62	45.24
L100	1-7/16	250	1134	1.799	21.59	32.39	64.77
L110	1-7/8	250	2268	3.599	43.18	64.77	129.55
L150	1-7/8	250	3708	5.883	70.60	105.90	211.80
L190	2-1/8	250	4680	7.426	89.11	133.66	267.32
L225	2-5/8	250	6228	9.882	118.58	177.87	355.74

Insert Characteristics

Properties	Buna-N (N)	Urethane (U)	Hytrel (H)	Bronze (B)
Oil Resistance	Good	Good	Excellent	Excellent
Chemical Resistance	Poor	Good	Excellent	Excellent
Flexibility	Excellent	Good	Fair	Poor
Temperature Range	F -40 to +212 C -40 to +100	-30 to +160 -34 to +71	-60 to +250 -51 to +121	-40 to +450 -40 to +232
Torsional Stiffness	Full Soft	Medium Soft	Hard	Hard
Average Hardness (Shore Number)	80A	90A	55D	—
Max. Misalignment				
• Angular	1°	1°	1/2°	1/2°
• Parallel	0.15"	0.15"	0.15"	0.10"

MD Flex Couplings Type J

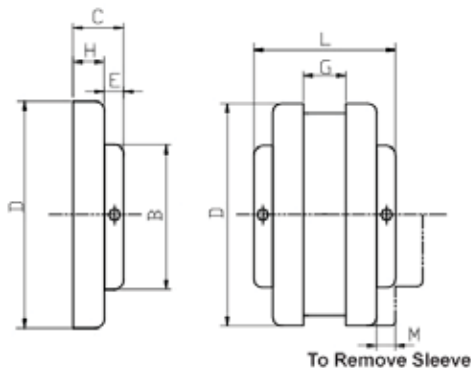

Flange Size	Dimensions (Inches)								Set Screw Thread Size	Set Screw Qty.	Wt. (lbs.)
	D	C	E	G	B	L	H	M			
3J	2.063	13/16	7/16	3/8	1 1/2	2	3/8	9/16	1/4-20 UNC X 1/4"	2	0.3
4J	2.461	7/8	7/16	5/8	1 5/8	2 3/8	7/16	3/4	1/4-20 UNC X 1/4"	2	0.4
5J	3.252	1 1/16	15/32	3/4	1 7/8	2 7/8	19/32	31/32	1/4-20 UNC X 1/4"	2	0.9
6J	4.000	1 7/32	19/32	7/8	1 15/16	3 5/16	5/8	1 3/32	5/16-18 UNC X 1/4"	2	1.2

Flange Size	Bore Range-inch	Keyseat-inch
3J	3/8	No Key
	1/2	1/8 x 1/16
	5/8, 3/4, 7/8	3/16 x 3/32
4J	1/2	1/8 x 1/16
	5/8, 3/4, 7/8	3/16 x 3/32
	15/16, 1	1/4 x 1/8
5J	1/2	1/8 x 1/16
	5/8, 3/4, 7/8	3/16 x 3/32
	15/16, 1, 1 1/8	1/4 x 1/8
6J	5/8, 3/4, 7/8	3/16 x 3/32
	15/16, 1, 1 1/8, 1 3/16, 1 1/4	1/4 x 1/8
	1 3/8	5/16 x 5/32

Flange Size	Bore Range-mm	Keyseat-mm
3J	11, 12	No Key
	14, 15, 16	5 x 2.3
	19	6 x 2.8
4J	14, 15, 16	5 x 2.3
	19, 20	6 x 2.8
	24, 25	8 x 3.3

Material: 3J-5J Powdered Metal, 6J Cast Iron

We do not recommend reboring the 3J & 4J flanges.

MD Flex Couplings Type S

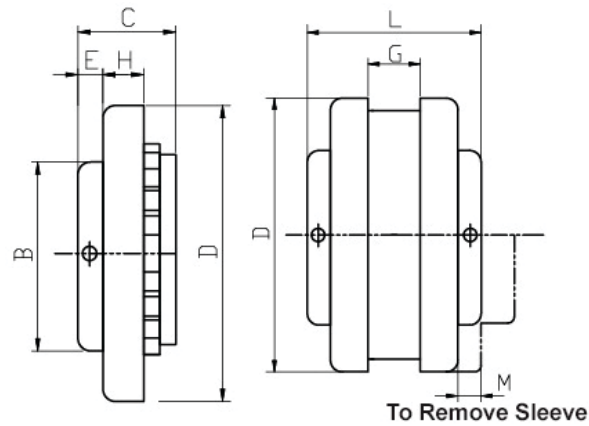

Flange Size	Dimensions (Inches)								Set Screw Thread Size	Set Screw Qty.	Wt. (lbs.)
	D	C	E	G	B	L	H	M			
5S	3.252	1 11/32	29/64	3/4	1 7/8	2 27/32	19/32	31/32	1/4-20 UNC X 1/4"	2	1.1
6S	4.000	1 5/8	9/16	7/8	2 1/2	3 9/16	25/32	1 3/32	5/16-18 UNC X 1/4"	2	1.9
7S	4.625	1 27/32	11/16	1	2 13/16	3 15/16	25/32	1 5/16	5/16-18 UNC X 1/4"	2	2.6
8S	5.449	2 3/32	3/4	1 1/8	3 1/4	4 7/16	29/32	1 1/2	3/8-16 UNC X 3/8"	2	4.4
9S	6.350	2 13/32	25/32	1 7/16	3 5/8	5 1/16	1 1/32	1 3/4	3/8-16 UNC X 3/8"	2	6.8
10S	7.500	2 23/32	13/16	1 5/8	4 3/8	5 11/16	1 7/32	2	3/8-16 UNC X 3/8"	2	10.5

Material: 5S Powdered Metal, 6S-10S Cast Iron

Flange Size	Bore Range-inch	Keyseat-inch
5S	5/8, 3/4, 13/16, 7/8	3/16 x 3/32
	15/16, 1, 1 1/16, 1 1/8, 1 3/16, 1 1/4	1/4 x 1/8
6S	3/4, 7/8	3/16 x 3/32
	15/16, 1, 1 1/16, 1 1/8, 1 3/16, 1 1/4	1/4 x 1/8
	1 5/16, 1 3/8	5/16 x 5/32
	1 7/16, 1 1/2	3/8 x 3/16
7S	3/4, 7/8	3/16 x 3/32
	15/16, 1, 1 1/16, 1 1/8, 1 3/16, 1 1/4	1/4 x 1/8
	1 5/16, 1 3/8	5/16 x 5/32
	1 7/16, 1 1/2, 1 5/8	3/8 x 3/16
8S	7/8	3/16 x 3/32
	15/16, 1, 1 1/16, 1 1/8, 1 3/16, 1 1/4	1/4 x 1/8
	1 5/16, 1 3/8	5/16 x 5/32
	1 7/16, 1 1/2, 1 9/16, 1 5/8, 1 11/16, 1 3/4	3/8 x 3/16
	1 7/8, 1 15/16, 2 1/16, 2 1/8	1/2 x 1/4
9S	15/16, 1, 1 1/16, 1 1/8, 1 1/4	1/4 x 1/8
	1 3/8	5/16 x 5/32
	1 7/16, 1 1/2, 1 9/16, 1 5/8, 1 11/16, 1 3/4	3/8 x 3/16
	1 7/8, 1 15/16, 2, 2 1/16, 2 1/8, 2 3/16, 2 1/4	1/2 x 1/4
	2 3/8, 2 1/2	5/8 x 5/16
10S	1 1/8, 1 1/4	1/4 x 1/8
	1 3/8	5/16 x 5/32
	1 7/16, 1 1/2, 1 9/16, 1 5/8, 1 11/16, 1 3/4	3/8 x 3/16
	1 7/8, 1 15/16, 2, 2 1/16, 2 1/8, 2 3/16, 2 1/4	1/2 x 1/4
	2 3/8, 2 7/16, 2 1/2, 2 5/8, 2 3/4	5/8 x 5/16
	2 7/8, 3	3/4 x 3/8

Flange Size	Bore Range-mm	Keyseat-mm
5S	14, 15, 16	5 x 2.3
	19, 20	6 x 2.8
	24, 25, 28	8 x 3.3
6S	15	5 x 2.3
	19, 20	6 x 2.8
	24, 25, 28, 30	8 x 3.3
	32, 35, 38	10 x 3.3
7S	19	6 x 2.8
	24, 25, 28, 30	8 x 3.3
	32, 35, 38	10 x 3.3
	42	12 x 3.3
8S	24, 28, 30	8 x 3.3
	32, 38	10 x 3.3
	42	12 x 3.3
	45, 48	14 x 3.8
9S	24, 30	8 x 3.3
	32, 38	10 x 3.3
	42	12 x 3.3
	45, 48	14 x 3.8
10S	30	8 x 3.3
	32, 35, 38	10 x 3.3
	42	12 x 3.3
	45, 48, 50	14 x 3.8
	55	16 x 4.3
	60	18 x 4.4

Element Characteristics

Shapes Available	EPDM	Neoprene	Hytrel
1pc, unsplit	JE	JN	H
1pc, split	JES	JNS	-
2pcs	-	-	HS
Typical Use	General Purpose	Oil Resist Non-flame	General Purpose
Rel. Rating	1X	1X	4X
Wind-Up Angular	15°	15°	7°
Misalignment	1°	1°	1/4°
Temperature (F)			
maximum	+272°	+200°	+250°
minimum	-30°	-0°	-65°

EPDM Elements

Dimensions

Part#	Coupling Size	D (Inches)	W (Inches)	Wt. (lbs.)
3JE	3	1 7/8	1	0.06
3JES	3	1 7/8	1	0.06
4JE	4	2 5/16	1 1/4	0.10
4JES	4	2 5/16	1 1/4	0.10
5JE	5	2 15/16	1 9/16	0.20
5JES	5	2 15/16	1 9/16	0.20
6JE	6	3 3/4	1 7/8	0.40
6JES	6	3 3/4	1 7/8	0.40
7JE	7	4 11/32	2 3/16	0.62
7JES	7	4 11/32	2 3/16	0.62
8JE	8	5 1/16	2 1/2	1.13
8JES	8	5 1/16	2 1/2	1.13
9JE	9	6	3	1.46
9JES	9	6	3	1.46
10JE	10	7 1/16	3 7/16	2.32
10JES	10	7 1/16	3 7/16	2.32

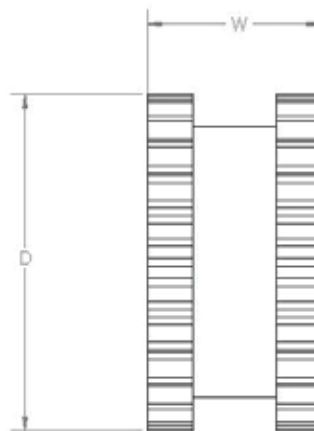

Coupling Ratings & Misalignment

Flange Size	EPDM Sleeves	Max. RPM	HP Per 100 RPM					Torque (in. lbs.)	Stiffness (in. lbs./rad)	E (inches)	Allow. Misalignment (inches)	
			Service Factor								Parallel	Angular
			1.0	1.5	2.0	2.5	3.0					
3	JE, JES	9200	0.1	0.07	0.05	0.04	0.03	60	229	1.188	0.010	0.035
4	JE, JES	7600	0.2	0.13	0.1	0.08	0.07	120	458	1.500	0.010	0.043
5	JE, JES	7600	0.4	0.27	0.2	0.16	0.13	240	916	1.938	0.015	0.056
6	JE, JES	6000	0.7	0.47	0.35	0.28	0.23	450	1718	2.375	0.015	0.070
7	JE, JES	5250	1.2	0.8	0.6	0.48	0.4	725	2769	2.563	0.020	0.081
8	JE, JES	4500	1.8	1.2	0.9	0.72	0.6	1135	4335	2.938	0.020	0.094
9	JE, JES	3750	2.9	1.93	1.45	1.16	0.97	1800	6875	3.500	0.025	0.109
10	JE, JES	3600	4.6	3.07	2.3	1.84	1.53	2875	10980	4.063	0.025	0.128

Neoprene Elements

Dimensions

Part#	Coupling Size	D (Inches)	W (Inches)	Wt. (lbs.)
3JN	3	1 7/8	1	0.06
3JNS	3	1 7/8	1	0.06
4JN	4	2 5/16	1 1/4	0.10
4JNS	4	2 5/16	1 1/4	0.10
5JN	5	2 15/16	1 9/16	0.20
5JNS	5	2 15/16	1 9/16	0.20
6JN	6	3 3/4	1 7/8	0.40
6JNS	6	3 3/4	1 7/8	0.40
7JN	7	4 11/32	2 3/16	0.62
7JNS	7	4 11/32	2 3/16	0.62
8JN	8	5 1/16	2 1/2	1.13
8JNS	8	5 1/16	2 1/2	1.13

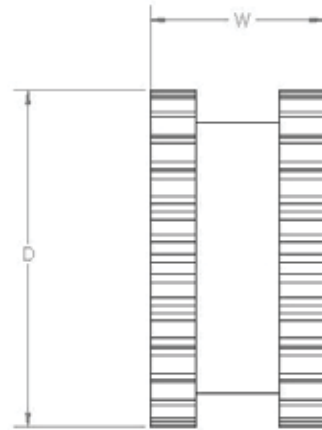

Coupling Ratings & Misalignment

Flange Size	Neoprene Sleeves	Max. RPM	HP Per 100 RPM					Torque (in. lbs.)	Stiffness (in. lbs./rad)	E (inches)	Allow. Misalignment (inches)	
			Service Factor								Parallel	Angular
			1.0	1.5	2.0	2.5	3.0					
3	JN, JNS	9200	0.1	0.07	0.05	0.04	0.03	60	229	1.188	0.010	0.035
4	JN, JNS	7600	0.2	0.13	0.1	0.08	0.07	120	458	1.500	0.010	0.043
5	JN, JNS	7600	0.4	0.27	0.2	0.16	0.13	240	916	1.938	0.015	0.056
6	JN, JNS	6000	0.7	0.47	0.35	0.28	0.23	450	1718	2.375	0.015	0.070
7	JN, JNS	5250	1.2	0.8	0.6	0.48	0.4	725	2769	2.563	0.020	0.081
8	JN, JNS	4500	1.8	1.2	0.9	0.72	0.6	1135	4335	2.938	0.020	0.094

Hytrel Elements

Dimensions

Part#	Coupling Size	D (Inches)	W (Inches)	Wt. (lbs.)
6H	6	3 3/4	1 7/8	0.44
6HS	6	3 3/4	1 7/8	0.44
7H	7	4 11/32	2 3/16	0.69
7HS	7	4 11/32	2 3/16	0.69
8H	8	5 1/16	2 1/2	1.40
8HS	8	5 1/16	2 1/2	1.40
9H	9	6	3	1.80
9HS	9	6	3	1.80
10H	10	7 1/16	3 7/16	2.90
10HS	10	7 1/16	3 7/16	2.90

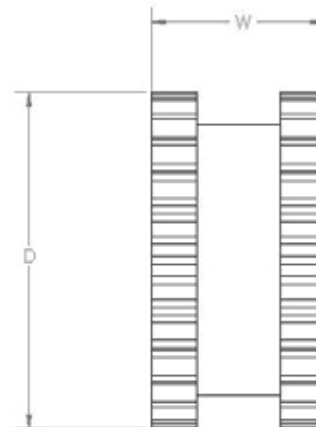

Coupling Ratings & Misalignment

Flange Size	Hytrel Sleeves	Max. RPM	HP Per 100 RPM					Torque (in. lbs.)	Stiffness (in. lbs./rad)	E (inches)	Allow. Misalignment (inches)	
			Service Factor								Parallel	Angular
			1.0	1.5	2.0	2.5	3.0					
6	H, HS	6000	2.90	1.93	1.45	1.16	0.97	1800	10000	2.372	0.010	0.016
7	H, HS	5250	4.60	3.07	2.30	1.84	1.53	2875	20000	2.563	0.012	0.020
8	H, HS	4500	7.20	4.80	3.60	2.88	2.40	4530	30000	2.938	0.015	0.025
9	H, HS	3750	11.40	7.60	5.70	4.56	3.80	7200	47500	3.500	0.017	0.028
10	H, HS	3600	18.00	12.00	9.00	7.20	6.00	11350	100000	4.063	0.020	0.032

MasterDrive[®] Light Duty V-Belts

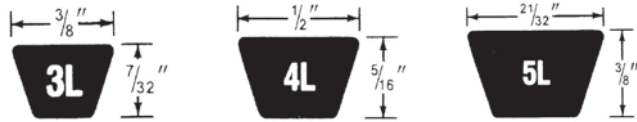
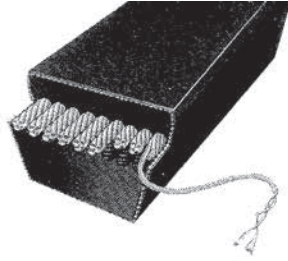

**MasterDrive[®]
Light Duty 3L V-Belts**

**MasterDrive[®]
Light Duty 4L V-Belts**

**MasterDrive[®]
Light Duty 5L V-Belts**

"3L" Light Duty V-Belts		
Outside		
Belt P/N	Length (inch)	Approx. Wt.
3L110	11.00	0.04
3L120	12.00	0.04
3L130	13.00	0.04
3L140	14.00	0.05
3L160	16.00	0.05
3L170	17.00	0.06
3L180	18.00	0.06
3L190	19.00	0.06
3L200	20.00	0.07
3L210	21.00	0.07
3L220	22.00	0.07
3L230	23.00	0.08
3L240	24.50	0.08
3L250	25.00	0.08
3L260	26.00	0.08
3L270	27.00	0.09
3L280	28.00	0.09
3L285	28.50	0.10
3L290	29.00	0.10
3L300	30.00	0.10
3L310	31.00	0.10
3L320	32.00	0.10
3L330	33.00	0.10
3L340	34.00	0.11
3L350	35.00	0.12
3L360	36.00	0.11
3L370	37.00	0.12
3L380	38.00	0.12
3L390	39.00	0.12
3L400	40.00	0.13
3L410	41.00	0.13
3L420	42.00	0.13
3L430	43.00	0.14
3L440	44.00	0.14
3L450	45.00	0.14
3L460	46.00	0.15
3L470	47.00	0.15

"3L" Light Duty V-Belts		
Outside		
Belt P/N	Length (inch)	Approx. Wt.
3L480	48.00	0.16
3L500	50.00	0.16
3L510	51.00	0.17
3L520	52.00	0.17
3L530	53.00	0.16
3L550	55.00	0.18
3L560	56.00	0.18
3L570	57.00	0.19
3L580	58.00	0.19
3L590	59.00	0.19
3L600	60.00	0.20
3L610	61.00	0.20
3L620	62.00	0.20
3L630	63.00	0.19
3L640	64.00	0.20
3L650	65.00	0.20
3L660	66.00	0.20
3L670	67.00	0.21
3L680	68.00	0.21
3L690	69.00	0.21
3L700	70.00	0.24
3L710	71.00	0.25
3L720	72.00	0.25
3L730	73.00	0.26
3L740	74.00	0.26

"4L" Light Duty V-Belts		
Outside		
Belt P/N	Length (inch)	Approx. Wt.
4L150	15.00	0.10
4L160	16.00	0.10
4L170	17.00	0.10
4L180	18.00	0.11
4L190	19.00	0.12
4L200	20.00	0.12
4L210	21.00	0.13
4L220	22.00	0.13

"4L" Light Duty V-Belts		
Outside		
Belt P/N	Length (inch)	Approx. Wt.
4L230	23.00	0.13
4L240	24.00	0.14
4L250	25.00	0.14
4L260	26.00	0.15
4L270	27.00	0.15
4L280	28.00	0.16
4L290	29.00	0.17
4L300	30.00	0.17
4L310	31.00	0.18
4L320	32.00	0.18
4L330	33.00	0.19
4L340	34.00	0.20
4L350	35.00	0.20
4L360	36.00	0.21
4L370	37.00	0.21
4L380	38.00	0.22
4L390	39.00	0.22
4L400	40.00	0.23
4L410	41.00	0.24
4L420	42.00	0.24
4L430	43.00	0.25
4L440	44.00	0.25
4L450	45.00	0.26
4L460	46.00	0.27
4L470	47.00	0.27
4L480	48.00	0.28
4L490	49.00	0.28
4L500	50.00	0.29
4L510	51.00	0.30
4L520	52.00	0.30
4L530	53.00	0.30
4L540	54.00	0.31
4L550	55.00	0.32
4L560	56.00	0.31
4L570	57.00	0.32
4L580	58.00	0.33
4L590	59.00	0.34
4L600	60.00	0.34
4L610	61.00	0.36
4L620	62.00	0.36

"4L" Light Duty V-Belts		
Outside		
Belt P/N	Length (inch)	Approx. Wt.
4L630	63.00	0.36
4L640	64.00	0.37
4L650	65.00	0.36
4L660	66.00	0.38
4L670	67.00	0.39
4L680	68.00	0.39
4L690	69.00	0.40
4L700	70.00	0.40
4L710	71.00	0.41
4L720	72.00	0.42
4L730	73.00	0.43
4L740	74.00	0.41
4L750	75.00	0.42
4L760	76.00	0.45
4L770	77.00	0.46
4L780	78.00	0.47
4L790	79.00	0.48
4L800	80.00	0.46
4L810	81.00	0.50
4L820	82.00	0.50
4L830	83.00	0.53
4L840	84.00	0.49
4L850	85.00	0.54
4L860	86.00	0.53
4L870	87.00	0.49
4L880	88.00	0.53
4L890	89.00	0.51
4L900	90.00	0.54
4L910	91.00	0.56
4L920	92.00	0.52
4L930	93.00	0.56
4L940	94.00	0.54
4L950	95.00	0.60
4L960	96.00	0.59
4L970	97.00	0.57
4L980	98.00	0.59
4L990	99.00	0.61
4L1000	100.00	0.62

"5L" Light Duty V-Belts		
Outside		
Belt P/N	Length (inch)	Approx. Wt.
5L230	23.00	0.21
5L240	24.00	0.22
5L250	25.00	0.23
5L260	26.00	0.24
5L270	27.00	0.23
5L280	28.00	0.26
5L290	29.00	0.27
5L300	30.00	0.28
5L310	31.00	0.28
5L320	32.00	0.30
5L330	33.00	0.31
5L340	34.00	0.32
5L350	35.00	0.33
5L360	36.00	0.34
5L370	37.00	0.35
5L380	38.00	0.35
5L390	39.00	0.36
5L400	40.00	0.38
5L410	41.00	0.39
5L420	42.00	0.40
5L430	43.00	0.40
5L440	44.00	0.41
5L450	45.00	0.43
5L460	46.00	0.43
5L470	47.00	0.44
5L480	48.00	0.45
5L490	49.00	0.46
5L500	50.00	0.47
5L510	51.00	0.48
5L520	52.00	0.48
5L530	53.00	0.50
5L540	54.00	0.51
5L550	55.00	0.50
5L560	56.00	0.51
5L570	57.00	0.52
5L580	58.00	0.54
5L590	59.00	0.56
5L600	60.00	0.67
5L610	61.00	0.58
5L620	62.00	0.59

"5L" Light Duty V-Belts		
Outside		
Belt P/N	Length (inch)	Approx. Wt.
5L630	63.00	0.60
5L640	64.00	0.61
5L650	65.00	0.62
5L660	66.00	0.60
5L670	67.00	0.63
5L680	68.00	0.64
5L690	69.00	0.65
5L700	70.00	0.66
5L710	71.00	0.67
5L720	72.00	0.68
5L730	73.00	0.69
5L740	74.00	0.71
5L750	75.00	0.71
5L760	76.00	0.72
5L770	77.00	0.73
5L780	78.00	0.74
5L790	79.00	0.77
5L800	80.00	0.76
5L810	81.00	0.77
5L820	82.00	0.76
5L830	83.00	0.79
5L840	84.00	0.78
5L850	85.00	0.83
5L860	86.00	0.82
5L870	87.00	0.85
5L880	88.00	0.84
5L890	89.00	0.85
5L900	90.00	0.87
5L910	91.00	0.82
5L920	92.00	0.84
5L930	93.00	0.88
5L940	94.00	0.91
5L950	95.00	0.92
5L960	96.00	0.89
5L970	97.00	0.87
5L980	98.00	0.95
5L990	99.00	0.94
5L1000	100.00	0.90

MasterDrive® Lawn & Garden Aramid V-Belts

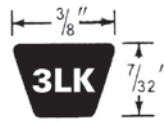
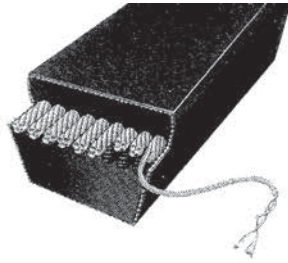

MasterDrive® Aramid 3LK V-Belts

MasterDrive® Aramid 4LK V-Belts

MasterDrive® Aramid 5LK V-Belts

"3LK" Aramid V-Belts		
Belt P/N	Outside Length (inch)	Approx. Wt.
3LK200	20.00	0.06
3LK210	21.00	0.06
3LK220	22.00	0.06
3LK230	23.00	0.06
3LK240	24.50	0.06
3LK250	25.00	0.06
3LK260	26.00	0.07
3LK270	27.00	0.07
3LK280	28.00	0.07
3LK290	29.00	0.08
3LK300	30.00	0.08
3LK310	31.00	0.09
3LK320	32.00	0.09
3LK330	33.00	0.09
3LK340	34.00	0.10
3LK350	35.00	0.10
3LK360	36.00	0.10
3LK370	37.00	0.11
3LK380	38.00	0.11
3LK390	39.00	0.11
3LK400	40.00	0.11
3LK410	41.00	0.12
3LK420	42.00	0.12
3LK430	43.00	0.12
3LK440	44.00	0.12
3LK450	45.00	0.12
3LK460	46.00	0.12
3LK470	47.00	0.13
3LK480	48.00	0.13
3LK490	49.00	0.13
3LK500	50.00	0.13
3LK510	51.00	0.14

"3LK" Aramid V-Belts		
Belt P/N	Outside Length (inch)	Approx. Wt.
3LK520	52.00	0.14
3LK530	53.00	0.14
3LK540	54.00	0.14
3LK550	55.00	0.15
3LK560	56.00	0.15
3LK570	57.00	0.15
3LK580	58.00	0.16
3LK590	59.00	0.16
3LK600	60.00	0.16
3LK610	61.00	0.16
3LK620	62.00	0.17
3LK630	63.00	0.17

"4LK" Aramid V-Belts		
Belt P/N	Outside Length (inch)	Approx. Wt.
4LK210	21.00	0.10
4LK215	21.50	0.11
4LK220	22.00	0.11
4LK230	23.00	0.11
4LK240	24.00	0.12
4LK250	25.00	0.12
4LK260	26.00	0.13
4LK270	27.00	0.13
4LK280	28.00	0.14
4LK290	29.00	0.14
4LK300	30.00	0.15
4LK310	31.00	0.15
4LK320	32.00	0.16
4LK330	33.00	0.16
4LK340	34.00	0.17
4LK350	35.00	0.17
4LK360	36.00	0.18

"4LK" Aramid V-Belts		
Belt P/N	Outside Length (inch)	Approx. Wt.
4LK370	37.00	0.20
4LK380	38.00	0.21
4LK390	39.00	0.22
4LK400	40.00	0.23
4LK410	41.00	0.23
4LK420	42.00	0.24
4LK430	43.00	0.25
4LK440	44.00	0.25
4LK450	45.00	0.26
4LK460	46.00	0.26
4LK470	47.00	0.27
4LK480	48.00	0.28
4LK490	49.00	0.28
4LK500	50.00	0.29
4LK510	51.00	0.29
4LK520	52.00	0.30
4LK530	53.00	0.30
4LK540	54.00	0.31
4LK550	55.00	0.32
4LK560	56.00	0.32
4LK570	57.00	0.33
4LK580	58.00	0.33
4LK590	59.00	0.34
4LK600	60.00	0.35
4LK610	61.00	0.35
4LK620	62.00	0.36
4LK630	63.00	0.36
4LK640	64.00	0.37
4LK650	65.00	0.37
4LK660	66.00	0.38
4LK670	67.00	0.39
4LK680	68.00	0.39

"4LK" Aramid V-Belts		
Belt P/N	Outside Length (inch)	Approx. Wt.
4LK690	69.00	0.40
4LK700	70.00	0.40
4LK710	71.00	0.41
4LK720	72.00	0.42
4LK730	73.00	0.42
4LK740	74.00	0.43
4LK750	75.00	0.43
4LK760	76.00	0.44
4LK770	77.00	0.44
4LK780	78.00	0.46
4LK790	79.00	0.47
4LK800	80.00	0.48
4LK810	81.00	0.49
4LK820	82.00	0.49
4LK830	83.00	0.50
4LK840	84.00	0.50
4LK850	85.00	0.51
4LK860	86.00	0.52
4LK870	87.00	0.52
4LK880	88.00	0.53
4LK890	89.00	0.53
4LK900	90.00	0.54
4LK910	91.00	0.55
4LK920	92.00	0.55
4LK930	93.00	0.56
4LK940	94.00	0.57
4LK950	95.00	0.57
4LK960	96.00	0.58
4LK970	97.00	0.58
4LK980	98.00	0.59
4LK990	99.00	0.60
4LK1000	100.00	0.60

"5LK" Aramid V-Belts		
Belt P/N	Outside Length (inch)	Approx. Wt.
5LK240	24.00	0.20
5LK250	25.00	0.20
5LK260	26.00	0.21
5LK270	27.00	0.22
5LK280	28.00	0.23
5LK290	29.00	0.24
5LK300	30.00	0.25
5LK310	31.00	0.26
5LK320	32.00	0.26
5LK330	33.00	0.27
5LK340	34.00	0.28
5LK350	35.00	0.29
5LK360	36.00	0.30
5LK370	37.00	0.31
5LK380	38.00	0.31
5LK390	39.00	0.32
5LK400	40.00	0.33
5LK410	41.00	0.34
5LK420	42.00	0.35
5LK430	43.00	0.36
5LK440	44.00	0.36
5LK450	45.00	0.37
5LK460	46.00	0.38
5LK470	47.00	0.40
5LK480	48.00	0.41
5LK490	49.00	0.42
5LK500	50.00	0.43
5LK510	51.00	0.44
5LK520	52.00	0.45
5LK530	53.00	0.46
5LK540	54.00	0.46
5LK550	55.00	0.47
5LK560	56.00	0.48
5LK570	57.00	0.49
5LK580	58.00	0.50
5LK590	59.00	0.51
5LK600	60.00	0.52
5LK610	61.00	0.53
5LK620	62.00	0.53

"5LK" Aramid V-Belts		
Belt P/N	Outside Length (inch)	Approx. Wt.
5LK630	63.00	0.54
5LK640	64.00	0.55
5LK650	65.00	0.56
5LK660	66.00	0.57
5LK670	67.00	0.58
5LK680	68.00	0.59
5LK690	69.00	0.60
5LK700	70.00	0.60
5LK710	71.00	0.61
5LK720	72.00	0.62
5LK730	73.00	0.63
5LK740	74.00	0.64
5LK750	75.00	0.65
5LK760	76.00	0.66
5LK770	77.00	0.66
5LK780	78.00	0.67
5LK790	79.00	0.68
5LK800	80.00	0.69
5LK810	81.00	0.71
5LK820	82.00	0.72
5LK830	83.00	0.73
5LK840	84.00	0.74
5LK850	85.00	0.74
5LK860	86.00	0.75
5LK870	87.00	0.76
5LK880	88.00	0.77
5LK890	89.00	0.78
5LK900	90.00	0.79
5LK910	91.00	0.80
5LK920	92.00	0.81
5LK930	93.00	0.81
5LK940	94.00	0.82
5LK950	95.00	0.83
5LK960	96.00	0.84
5LK970	97.00	0.85
5LK980	98.00	0.86
5LK990	99.00	0.87
5LK1000	100.00	0.88

MasterDrive[®] Classical V-Belts

A V-Belts

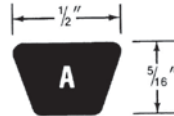
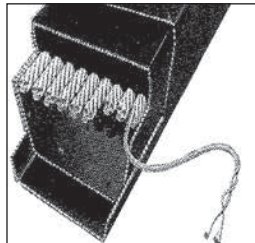

"A" V-Belts		
Outside		
Belt P/N	Length (inch)	Approx. Wt.
A19	21	0.12
A20	22	0.15
A21	23	0.16
A22	24	0.16
A23	25	0.17
A24	26	0.18
A25	27	0.18
A26	28	0.19
A27	29	0.20
A28	30	0.20
A29	31	0.21
A30	32	0.22
A31	33	0.22
A32	34	0.23
A33	35	0.24
A34	36	0.24
A35	37	0.25
A36	38	0.26
A37	39	0.26
A38	40	0.27
A39	41	0.27
A40	42	0.28
A41	43	0.29
A42	44	0.29
A43	45	0.30
A44	46	0.30
A45	47	0.31
A46	48	0.32
A47	49	0.32
A48	50	0.33
A49	51	0.33
A50	52	0.34

"A" V-Belts		
Outside		
Belt P/N	Length (inch)	Approx. Wt.
A51	53	0.34
A52	54	0.35
A53	55	0.36
A54	56	0.36
A55	57	0.37
A56	58	0.37
A57	59	0.38
A58	60	0.38
A59	61	0.39
A60	62	0.39
A61	63	0.40
A62	64	0.40
A63	65	0.41
A64	66	0.41
A65	67	0.42
A66	68	0.42
A67	69	0.43
A68	70	0.43
A69	71	0.44
A70	72	0.44
A71	73	0.45
A72	74	0.45
A73	75	0.45
A74	76	0.46
A75	77	0.47
A76	78	0.47
A77	79	0.48
A78	80	0.49
A79	81	0.49
A80	82	0.50
A81	83	0.50
A82	84	0.51

"A" V-Belts		
Outside		
Belt P/N	Length (inch)	Approx. Wt.
A83	85	0.52
A84	86	0.52
A85	87	0.53
A86	88	0.54
A87	89	0.54
A88	90	0.55
A89	91	0.56
A90	92	0.56
A91	93	0.57
A92	94	0.58
A93	95	0.59
A94	96	0.59
A95	97	0.60
A96	98	0.61
A97	99	0.61
A98	100	0.62
A99	101	0.63
A100	102	0.63
A101	103	0.64
A102	104	0.65
A103	105	0.65
A104	106	0.66
A105	107	0.67
A106	108	0.67
A107	109	0.69
A108	110	0.69
A109	111	0.70
A110	112	0.71
A112	114	0.71
A113	115	0.72
A114	116	0.72
A115	117	0.74

"A" V-Belts		
Outside		
Belt P/N	Length (inch)	Approx. Wt.
A116	118	0.74
A120	122	0.77
A123	125	0.79
A124	126	0.79
A125	127	0.81
A126	128	0.80
A128	130	0.83
A130	132	0.84
A133	135	0.86
A135	137	0.88
A136	138	0.88
A137	139	0.87
A138	140	0.88
A140	142	0.91
A144	146	0.94
A150	152	0.98
A154	156	0.95
A155	157	1.02
A156	158	1.03
A158	160	1.04
A160	162	1.06
A167	169	1.12
A173	175	1.15
A180	182	1.20
A237	239	1.65

MasterDrive® Classical Cogged V-Belts

AX V-Belts

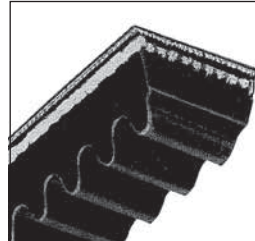
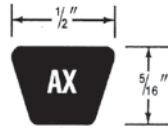

“AX” V-Belts Cogged		
Belt P/N	Outside Length (inch)	Approx. Wt.
AX20	22	0.14
AX21	23	0.14
AX22	24	0.15
AX23	25	0.15
AX24	26	0.16
AX25	27	0.17
AX26	28	0.17
AX27	29	0.18
AX28	30	0.18
AX29	31	0.19
AX30	32	0.20
AX31	33	0.20
AX32	34	0.21
AX33	35	0.21
AX34	36	0.22
AX35	37	0.23
AX36	38	0.23
AX37	39	0.24
AX38	40	0.24
AX39	41	0.25
AX40	42	0.25
AX41	43	0.26
AX42	44	0.26
AX43	45	0.27
AX44	46	0.27
AX45	47	0.28
AX46	48	0.28
AX47	49	0.29
AX48	50	0.29

“AX” V-Belts Cogged		
Belt P/N	Outside Length (inch)	Approx. Wt.
AX49	51	0.30
AX50	52	0.30
AX52	54	0.31
AX53	55	0.32
AX54	56	0.32
AX55	57	0.32
AX56	58	0.33
AX57	59	0.33
AX58	60	0.34
AX59	61	0.34
AX60	62	0.35
AX61	63	0.35
AX62	64	0.36
AX63	65	0.37
AX64	66	0.38
AX65	67	0.38
AX66	68	0.49
AX67	69	0.40
AX68	70	0.41
AX69	71	0.42
AX70	72	0.42
AX71	73	0.43
AX73	75	0.45
AX74	76	0.46
AX75	77	0.46
AX77	79	0.48
AX78	80	0.49
AX79	81	0.50
AX80	82	0.51

“AX” V-Belts Cogged		
Belt P/N	Outside Length (inch)	Approx. Wt.
AX81	83	0.52
AX82	84	0.52
AX83	85	0.53
AX84	86	0.54
AX85	87	0.55
AX86	88	0.56
AX87	89	0.57
AX88	90	0.58
AX89	91	0.59
AX90	92	0.60
AX91	93	0.60
AX92	94	0.61
AX93	95	0.62
AX95	97	0.64
AX97	99	0.66
AX98	100	0.67
AX99	101	0.68
AX100	102	0.69
AX103	105	0.72
AX105	107	0.74
AX110	112	0.79
AX112	114	0.81
AX120	122	0.90
AX128	130	0.96
AX136	138	1.02

MasterDrive[®] Classical V-Belts

B V-Belts

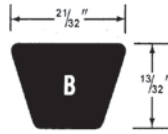
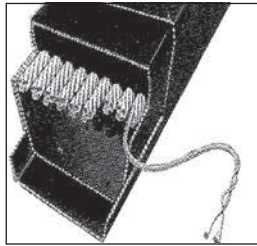

"B" V-Belts Outside		
Belt P/N	Length (inch)	Approx. Wt.
B24	27	0.27
B25	28	0.28
B26	29	0.30
B27	30	0.31
B28	31	0.32
B29	32	0.33
B30	33	0.34
B31	34	0.35
B32	35	0.36
B33	36	0.37
B34	37	0.39
B35	38	0.40
B36	39	0.41
B37	40	0.42
B38	41	0.43
B39	42	0.44
B40	43	0.45
B41	44	0.46
B42	45	0.47
B43	46	0.49
B44	47	0.50
B45	48	0.51
B46	49	0.52
B47	50	0.53
B48	51	0.54
B49	52	0.55
B50	53	0.56
B51	54	0.57
B52	55	0.58
B53	56	0.59
B54	57	0.61
B55	58	0.62
B56	59	0.63
B57	60	0.64
B58	61	0.65
B59	62	0.66
B60	63	0.67
B61	64	0.68
B62	65	0.69
B63	66	0.70
B64	67	0.71
B65	68	0.72
B66	69	0.73
B67	70	0.74
B68	71	0.76
B69	72	0.77
B70	73	0.78
B71	74	0.79

"B" V-Belts Outside		
Belt P/N	Length (inch)	Approx. Wt.
B72	75	0.80
B73	76	0.81
B74	77	0.82
B75	78	0.83
B76	79	0.84
B77	80	0.85
B78	81	0.86
B79	82	0.87
B80	83	0.88
B81	84	0.89
B82	85	0.90
B83	86	0.91
B84	87	0.92
B85	88	0.93
B86	89	0.94
B87	90	0.95
B88	91	0.96
B89	92	0.97
B90	93	0.98
B91	94	0.99
B92	95	1.00
B93	96	1.01
B94	97	1.03
B95	98	1.04
B96	99	1.05
B97	100	1.06
B98	101	1.07
B99	102	1.08
B100	103	1.09
B102	105	1.11
B103	106	1.12
B104	107	1.13
B105	108	1.14
B106	109	1.15
B107	110	1.16
B108	111	1.17
B109	112	1.18
B110	113	1.19
B112	115	1.21
B113	116	1.22
B114	117	1.23
B115	118	1.24
B116	119	1.25
B117	120	1.26
B118	121	1.28
B120	123	1.30
B122	125	1.32
B123	126	1.33

"B" V-Belts Outside		
Belt P/N	Length (inch)	Approx. Wt.
B124	127	1.34
B125	128	1.35
B126	129	1.36
B128	131	1.38
B130	133	1.41
B131	134	1.42
B132	135	1.43
B133	136	1.44
B134	137	1.45
B135	138	1.46
B136	139	1.47
B137	140	1.48
B138	141	1.49
B140	143	1.51
B141	144	1.52
B142	145	1.53
B143	146	1.55
B144	147	1.56
B145	148	1.57
B146	149	1.58
B147	150	1.59
B148	151	1.60
B149	152	1.61
B150	153	1.62
B151	154	1.63
B152	155	1.64
B153	156	1.65
B154	157	1.66
B155	158	1.67
B156	159	1.69
B158	161	1.71
B160	163	1.73
B161	164	1.74
B162	165	1.75
B163	166	1.76
B164	167	1.77
B165	168	1.78
B166	169	1.79
B167	170	1.80
B168	171	1.82
B169	172	1.83
B170	173	1.84
B173	176	1.87
B175	178	1.89
B178	181	1.92
B180	183	1.94
B182	185	1.97
B185	188	1.99

"B" V-Belts Outside		
Belt P/N	Length (inch)	Approx. Wt.
B187	190	2.10
B188	191	2.30
B190	193	2.05
B191	194	2.06
B192	195	2.07
B195	198	2.11
B196	199	2.12
B199	202	2.15
B201	204	2.18
B204	207	2.20
B205	208	2.21
B206	209	2.22
B210	213	2.27
B212	215	2.30
B214	217	2.32
B215	218	2.35
B218	221	2.37
B220	223	2.38
B221	224	2.39
B225	228	2.43
B230	233	2.47
B233	236	2.50
B236	239	2.53
B237	240	2.56
B240	243	2.59
B255	258	2.75
B257	260	2.79
B260	263	2.85
B270	273	2.91
B285	288	3.07
B291	294	3.10
B292	295	3.15
B293	296	3.16
B300	303	3.23
B315	318	3.39
B326	329	3.51
B330	333	3.55
B360	363	3.88
B375	378	4.00

MasterDrive® Classical Cogged V-Belts

BX V-Belts

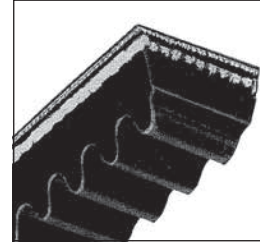
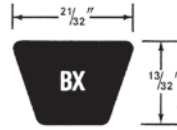

"BX" V-Belts Cogged		
Belt P/N	Length (inch)	Approx. Wt.
BX21	24	0.21
BX22	25	0.22
BX25	28	0.25
BX27	30	0.27
BX28	31	0.28
BX29	32	0.29
BX30	33	0.30
BX32	35	0.32
BX33	36	0.33
BX34	37	0.34
BX35	38	0.35
BX36	39	0.36
BX37	40	0.37
BX38	41	0.38
BX39	42	0.39
BX40	43	0.40
BX41	44	0.41
BX42	45	0.42
BX43	46	0.43
BX44	47	0.44
BX45	48	0.45
BX46	49	0.46
BX47	50	0.47
BX48	51	0.48
BX49	52	0.49
BX50	53	0.50
BX51	54	0.51
BX52	55	0.52
BX53	56	0.53
BX54	57	0.54
BX55	58	0.55
BX56	59	0.56
BX57	60	0.57
BX58	61	0.58
BX59	62	0.59
BX60	63	0.60
BX61	64	0.61
BX62	65	0.62
BX63	66	0.63
BX64	67	0.64
BX65	68	0.65

"BX" V-Belts Cogged		
Belt P/N	Length (inch)	Approx. Wt.
BX66	69	0.66
BX67	70	0.67
BX68	71	0.68
BX69	72	0.69
BX70	73	0.70
BX71	74	0.71
BX72	75	0.72
BX73	76	0.73
BX74	77	0.74
BX76	79	0.76
BX77	80	0.77
BX79	82	0.79
BX80	83	0.80
BX81	84	0.81
BX82	85	0.82
BX83	86	0.83
BX84	87	0.84
BX85	88	0.85
BX86	89	0.86
BX87	90	0.87
BX88	91	0.88
BX89	92	0.89
BX90	93	0.90
BX91	94	0.91
BX92	95	0.92
BX93	96	0.93
BX94	97	0.94
BX95	98	0.95
BX96	99	0.96
BX97	100	0.97
BX98	101	0.98
BX99	102	0.99
BX100	103	1.00
BX101	104	1.01
BX102	105	1.03
BX103	106	1.04
BX104	107	1.05
BX105	108	1.06
BX106	109	1.07
BX107	110	1.08
BX108	111	1.09

"BX" V-Belts Cogged		
Belt P/N	Length (inch)	Approx. Wt.
BX110	113	1.11
BX112	115	1.14
BX113	116	1.15
BX115	118	1.17
BX116	119	1.18
BX117	120	1.19
BX118	121	1.20
BX120	123	1.23
BX122	125	1.25
BX123	126	1.32
BX124	127	1.27
BX125	128	1.28
BX128	131	1.32
BX130	133	1.34
BX133	136	1.37
BX134	137	1.38
BX136	139	1.41
BX138	141	1.43
BX140	143	1.45
BX142	145	1.48
BX143	146	1.48
BX144	147	1.50
BX148	151	1.55
BX150	153	1.57
BX158	161	1.67
BX160	163	1.69
BX162	165	1.71
BX173	176	1.85
BX195	198	2.12

MasterDrive[®] Classical V-Belts

B Banded V-Belts

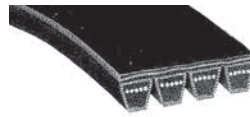

"B" V-Belts		
Outside		
Belt P/N	Length (inch)	Approx. Wt.
3/B55	58	2.16
4/B55	58	2.88
2/B60	63	1.57
3/B60	63	2.36
4/B60	63	3.14
3/B61	64	2.39
4/B61	64	3.19
5/B61	64	3.99
2/B62	65	1.62
3/B62	65	2.43
4/B62	65	3.25
2/B63	66	1.65
3/B63	66	2.47
4/B63	66	3.30
2/B64	67	1.67
3/B64	67	2.51
4/B64	67	3.35
5/B64	67	4.19
2/B65	68	1.70
3/B65	68	2.55
2/B66	69	1.73
3/B66	69	2.59
4/B66	69	3.46
2/B67	70	1.75
3/B67	70	2.63
2/B68	71	1.78
3/B68	71	2.67
4/B68	71	3.56
2/B70	73	1.83
3/B70	73	2.75
4/B70	73	3.67
2/B71	74	1.86
3/B71	74	2.79
4/B71	74	3.72
2/B72	75	1.88
3/B72	75	2.83
4/B72	75	3.77

"B" V-Belts		
Outside		
Belt P/N	Length (inch)	Approx. Wt.
2/B73	76	1.91
3/B73	76	2.87
5/B73	76	4.78
2/B74	77	1.94
3/B74	77	2.91
4/B74	77	3.88
5/B74	77	4.85
2/B75	78	1.96
3/B75	78	2.95
4/B75	78	3.93
5/B75	78	4.91
2/B77	80	2.01
3/B77	80	3.02
4/B77	80	4.03
5/B77	80	5.04
2/B78	81	2.04
3/B78	81	3.06
4/B78	81	4.09
5/B78	81	5.11
2/B79	82	2.07
4/B79	82	4.14
5/B79	82	5.17
2/B80	83	2.09
3/B80	83	3.14
4/B80	83	4.19
5/B80	83	5.24
2/B81	84	2.12
3/B81	84	3.18
4/B81	84	4.24
5/B81	84	5.30
2/B82	85	2.15
3/B82	85	3.22
4/B82	85	4.30
2/B83	86	2.17
3/B83	86	3.26
4/B83	86	4.35

"B" V-Belts		
Outside		
Belt P/N	Length (inch)	Approx. Wt.
2/B85	88	2.22
3/B85	88	3.34
4/B85	88	4.45
2/B86	89	2.25
3/B86	89	3.38
4/B86	89	4.51
5/B86	89	5.63
2/B87	90	2.28
3/B87	90	3.42
4/B87	90	4.56
5/B87	90	5.70
2/B88	91	2.30
3/B88	91	3.46
4/B88	91	4.61
5/B88	91	5.76
2/B90	93	2.36
3/B90	93	3.54
4/B90	93	4.72
2/B91	94	2.40
3/B91	94	3.60
4/B91	94	4.80
5/B91	94	6.00
2/B93	96	2.43
3/B93	96	3.65
4/B93	96	4.87
5/B93	96	6.09
2/B95	98	2.49
3/B95	98	3.73
4/B95	98	4.98
5/B95	98	6.22
3/B96	99	3.77
4/B96	99	5.03
2/B97	100	2.54
3/B97	100	3.81
4/B97	100	5.08
5/B97	100	6.35

"B" V-Belts		
Outside		
Belt P/N	Length (inch)	Approx. Wt.
2/B98	101	2.56
4/B98	101	5.12
2/B99	102	2.59
3/B99	102	3.89
4/B99	102	5.19
2/B100	103	2.62
3/B100	103	3.93
4/B100	103	5.24
2/B103	106	2.70
3/B103	106	4.05
4/B103	106	5.40
5/B103	106	6.75
2/B104	107	2.72
3/B104	107	4.09
4/B104	107	5.45
5/B104	107	6.81
2/B105	108	2.75
3/B105	108	4.13
4/B105	108	5.50
2/B107	110	2.80
3/B107	110	4.20
4/B107	110	5.61
2/B108	111	2.83
3/B108	111	4.24
4/B108	111	5.66
5/B108	111	7.07
2/B110	113	2.88
3/B110	113	4.32
4/B110	113	5.76
5/B110	113	7.21
2/B111	114	2.91
3/B111	114	4.36
4/B111	114	5.82
2/B112	115	2.93
3/B112	115	4.40
4/B112	115	5.87

MasterDrive[®] Classical V-Belts

B Banded V-Belts

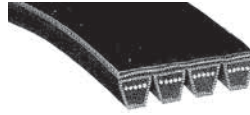

"B" V-Belts Outside		
Belt P/N	Length (inch)	Approx. Wt.
2/B114	117	2.98
3/B114	117	4.48
4/B114	117	5.97
2/B115	118	3.01
3/B115	118	4.52
2/B116	119	3.08
3/B116	119	4.60
4/B116	119	6.19
5/B116	119	7.70
2/B120	123	3.14
3/B120	123	4.72
4/B120	123	6.29
5/B120	123	7.86
2/B124	127	3.25
3/B124	127	4.87
4/B124	127	6.50
5/B124	127	8.12
2/B128	131	3.35
3/B128	131	5.03
4/B128	131	6.71
5/B128	131	8.39
2/B133	136	3.48
3/B133	136	5.23
4/B133	136	6.97
5/B133	136	8.71
2/B136	139	3.56
3/B136	139	5.34
4/B136	139	7.13
5/B136	139	8.91
2/B140	143	3.65
3/B140	143	5.50
4/B140	143	7.30

"B" V-Belts Outside		
Belt P/N	Length (inch)	Approx. Wt.
2/B144	147	3.77
3/B144	147	5.66
4/B144	147	7.55
5/B144	147	9.43
2/B148	151	3.88
3/B148	151	5.82
4/B148	151	7.76
5/B148	151	9.70
2/B150	153	3.93
3/B150	153	5.89
4/B150	153	7.86
5/B150	153	9.83
2/B154	157	4.00
3/B154	157	6.00
4/B154	157	8.00
5/B154	157	10.00
2/B158	161	4.14
3/B158	161	6.21
4/B158	161	8.28
5/B158	161	10.35
2/B162	165	4.24
3/B162	165	6.37
4/B162	165	8.49
5/B162	165	10.61
2/B173	176	4.53
3/B173	176	6.80
4/B173	176	9.07
5/B173	176	11.34
2/B180	183	4.72
3/B180	183	7.07
4/B180	183	9.43
5/B180	183	11.79

"B" V-Belts Outside		
Belt P/N	Length (inch)	Approx. Wt.
3/B190	193	7.40
4/B190	193	9.80
5/B190	193	12.40
2/B195	198	5.11
3/B195	198	7.66
4/B195	198	10.22
5/B195	198	12.78
2/B210	213	5.50
3/B210	213	8.25
4/B210	213	11.01
5/B210	213	13.76
2/B225	228	5.89
3/B225	228	8.84
4/B225	228	11.79
2/B240	243	6.29
3/B240	243	9.43
4/B240	243	12.58
2/B255	258	6.68
4/B255	258	13.37
3/B285	288	11.20
5/B285	288	18.68

MasterDrive[®] Classical Cogged V-Belts

BX Banded V-Belts

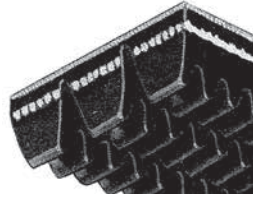

"BX" V-Belts Cogged		
Belt P/N	Outside Length (inch)	Approx. Wt.
2/BX105	108	3.10
3/BX105	108	4.65
4/BX105	108	6.20
2/BX128	131	3.80
2/BX136	139	4.00
3/BX136	139	6.00
4/BX136	139	8.00
5/BX136	139	10.10
2/BX144	147	4.27
3/BX144	147	6.41
4/BX144	147	8.55
5/BX144	147	10.68
2/BX158	161	4.69
3/BX158	161	7.03
5/BX158	161	11.72
2/BX195	198	5.78
3/BX195	198	8.68
4/BX195	198	11.57

MasterDrive® Classical V-Belts C V-Belts

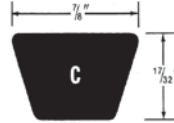
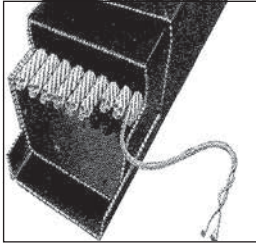

"C" V-Belts Outside		
Belt P/N	Length (inch)	Approx. Wt.
C46	50	0.80
C47	51	0.82
C48	52	0.83
C49	53	0.85
C51	55	0.88
C52	56	0.90
C53	57	0.92
C54	58	0.93
C55	59	0.95
C57	61	0.98
C58	62	1.00
C59	63	1.02
C60	64	1.04
C61	65	1.05
C62	66	1.07
C63	67	1.09
C64	68	1.10
C65	69	1.12
C66	70	1.14
C67	71	1.16
C68	72	1.17
C69	73	1.19
C70	74	1.21
C71	75	1.22
C73	77	1.26
C74	78	1.28
C75	79	1.29
C76	80	1.31
C78	82	1.34
C80	84	1.38
C81	85	1.39
C82	86	1.41
C83	87	1.43
C84	88	1.45
C85	89	1.46
C86	90	1.48

"C" V-Belts Outside		
Belt P/N	Length (inch)	Approx. Wt.
C87	91	1.50
C90	94	1.55
C91	95	1.56
C92	96	1.58
C93	97	1.60
C94	98	1.61
C95	99	1.63
C96	100	1.65
C97	101	1.67
C98	102	1.68
C99	103	1.70
C100	104	1.72
C101	105	1.73
C102	106	1.75
C103	107	1.77
C104	108	1.78
C105	109	1.80
C106	110	1.82
C107	111	1.83
C108	112	1.85
C109	113	1.87
C110	114	1.88
C111	115	1.90
C112	116	1.92
C113	117	1.93
C114	118	1.95
C115	119	1.97
C116	120	1.98
C117	121	2.00
C118	122	2.02
C119	123	2.04
C120	124	2.05
C122	126	2.09
C124	128	2.12
C125	129	2.14
C126	130	2.15

"C" V-Belts Outside		
Belt P/N	Length (inch)	Approx. Wt.
C128	132	2.19
C130	134	2.22
C131	135	2.24
C132	136	2.25
C133	137	2.27
C134	138	2.29
C135	139	2.30
C136	140	2.32
C138	142	2.35
C139	143	2.37
C140	144	2.48
C141	145	2.49
C142	146	2.51
C143	147	2.53
C144	148	2.55
C145	149	2.56
C147	151	2.60
C150	154	2.65
C151	155	2.67
C152	156	2.68
C153	157	2.70
C154	158	2.72
C155	159	2.74
C156	160	2.75
C158	162	2.79
C160	164	2.82
C162	166	2.86
C163	167	2.88
C164	168	2.89
C165	169	2.91
C166	170	2.92
C167	171	2.94
C168	172	2.96
C169	173	2.98
C170	174	3.00
C171	175	3.02

"C" V-Belts Outside		
Belt P/N	Length (inch)	Approx. Wt.
C173	177	3.05
C175	179	3.08
C177	181	3.12
C180	184	3.17
C182	186	3.20
C183	187	3.22
C184	188	3.24
C185	189	3.25
C187	191	3.28
C188	192	3.31
C190	194	3.34
C195	199	3.43
C196	200	3.44
C197	201	3.48
C202	206	3.55
C206	210	3.61
C207	211	3.63
C210	214	3.68
C212	216	3.72
C214	218	3.75
C218	222	3.82
C225	227	3.94
C235	237	4.00
C240	242	4.19
C246	248	4.30
C250	252	4.38
C255	257	4.45
C270	272	4.70
C280	282	4.87
C285	287	4.95
C300	302	5.20
C315	317	5.45
C320	322	5.54
C345	347	4.28
C360	362	6.20
C390	392	6.69

MasterDrive[®] Classical V-Belts

CX V-Belts

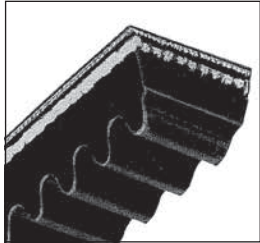
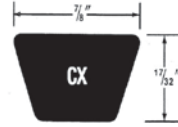

"CX" Cogged V-Belts		
Outside		
Belt P/N	Length (inch)	Approx. Wt.
CX51	55	0.89
CX60	64	1.05
CX68	72	1.22
CX75	79	1.37
CX81	85	1.51
CX85	89	1.60
CX90	94	1.72
CX95	99	1.84
CX96	100	1.87
CX100	104	1.97
CX101	105	1.99
CX109	113	2.20
CX112	116	2.28
CX115	119	2.36
CX124	128	2.57
CX126	130	2.61
CX128	132	2.65
CX132	136	2.72
CX136	140	2.80
CX144	148	2.95
CX150	154	3.06
CX158	162	3.20
CX162	166	3.28
CX173	177	3.47
CX180	184	3.60
CX195	199	3.85
CX210	214	4.11
CX225	227	4.35
CX240	242	4.60

MasterDrive® Classical V-Belts

C Banded V-Belts

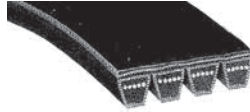

“C” Banded V-Belts		
Belt P/N	Outside	
	Length (inch)	Approx. Wt.
4/C68	72	6.64
5/C68	72	8.30
3/C71	75	5.20
4/C71	75	6.93
5/C71	75	8.66
2/C75	79	3.66
3/C75	79	5.49
4/C75	79	7.32
2/C81	85	3.95
3/C81	85	5.93
4/C81	85	7.90
5/C81	85	9.88
2/C85	89	4.15
3/C85	89	6.22
5/C85	89	10.37
2/C90	94	4.39
3/C90	94	6.59
4/C90	94	8.78
5/C90	94	10.98
2/C96	100	4.68
3/C96	100	7.03
4/C96	100	9.37
5/C96	100	11.71
2/C97	101	4.73
4/C97	101	9.47
5/C97	101	11.84
2/C99	103	4.83
3/C99	103	7.25
4/C99	103	9.66
2/C100	104	4.88
3/C100	104	7.32
4/C100	104	9.76
5/C100	104	12.20
2/C105	109	5.12
3/C105	109	7.69
4/C105	109	10.25
5/C105	109	12.81

“C” Banded V-Belts		
Belt P/N	Outside	
	Length (inch)	Approx. Wt.
2/C108	112	5.27
3/C108	112	7.90
4/C108	112	10.54
2/C109	113	5.32
3/C109	113	7.98
4/C109	113	10.64
5/C109	113	13.30
2/C112	116	5.46
3/C112	116	8.20
4/C112	116	10.93
5/C112	116	13.67
2/C120	124	5.85
3/C120	124	8.78
4/C120	124	11.71
5/C120	124	14.64
2/C124	128	6.05
3/C124	128	9.08
4/C124	128	12.10
5/C124	128	15.13
2/C128	132	6.24
3/C128	132	9.37
4/C128	132	12.49
5/C128	132	15.62
2/C136	140	6.64
3/C136	140	9.96
4/C136	140	13.28
5/C136	140	16.60
2/C144	148	7.03
3/C144	148	10.54
4/C144	148	14.06
5/C144	148	17.57
2/C158	162	7.71
3/C158	162	11.57
4/C158	162	15.42
5/C158	162	19.28

“C” Banded V-Belts		
Belt P/N	Outside	
	Length (inch)	Approx. Wt.
2/C162	166	7.90
3/C162	166	11.86
4/C162	166	15.81
5/C162	166	19.77
2/C173	177	8.44
3/C173	177	12.67
4/C173	177	16.89
5/C173	177	21.11
4/C180	184	17.57
5/C180	184	21.97
2/C195	199	9.52
3/C195	199	14.28
4/C195	199	19.04
2/C210	214	10.25
3/C210	214	15.37
4/C210	214	20.50
5/C210	214	25.63
2/C225	227	10.98
3/C225	227	16.47
4/C225	227	21.97
5/C225	227	27.46
2/C240	242	11.71
3/C240	242	17.57
4/C240	242	23.43
5/C240	242	29.29
2/C255	257	12.45
3/C255	257	18.67
4/C255	257	24.90
5/C255	257	31.12
2/C270	272	13.18
3/C270	272	19.77
4/C270	272	26.36
5/C270	272	32.95

“C” Banded V-Belts		
Belt P/N	Outside	
	Length (inch)	Approx. Wt.
2/C285	287	13.91
3/C285	287	20.87
4/C285	287	27.82
2/C300	302	14.64
3/C300	302	21.97
4/C300	302	29.29
5/C300	302	36.61
2/C315	317	15.37
3/C315	317	23.06
4/C315	317	30.75
5/C315	317	38.44
2/C330	332	16.11
3/C330	332	24.16
4/C330	332	32.22
5/C330	332	40.27
2/C345	347	16.84
4/C345	347	33.68
5/C345	347	42.11
2/C360	362	17.57
3/C360	362	26.36
4/C360	362	35.15
5/C360	362	43.94
2/C390	392	19.04
3/C390	392	28.56
4/C390	392	38.08
5/C390	392	47.60
3/C420	422	30.75
4/C420	422	41.01
5/C420	422	51.26

MasterDrive[®] Classical Cogged V-Belts **CX Banded V-Belts**

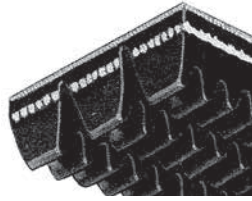

"CX" V-Belts Cogged		
	Outside	
Belt P/N	Length (inch)	Approx. Wt.
2/CX112	116	5.54
4/CX112	116	11.09
2/CX173	177	8.56
5/CX173	177	21.41

MasterDrive® Wedge and Cogged Raw Edge V-Belts 3V & 3VX, 5V & 5VX, 8V Belts

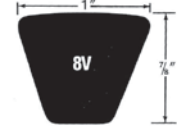
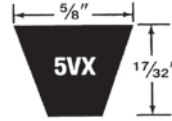
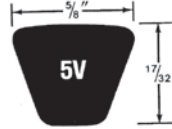
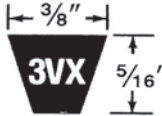
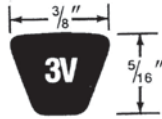

“3V & 3VX” V-Belts

“5V & 5VX” V-Belts

“8V” V-Belts

“3V” Belts		
Belt P/N	Outside Length (inch)	Approx. Wt.
3V250	25	0.11
3V265	26.5	0.12
3V280	28	0.13
3V300	30	0.14
3V315	31.5	0.14
3V335	33.5	0.15
3V355	35.5	0.16
3V375	37.5	0.17
3V400	40	0.18
3V450	45	0.21
3V475	47.5	0.22
3V500	50	0.23
3V530	53	0.24
3V560	56	0.26
3V600	60	0.28
3V630	63	0.29
3V670	67	0.31
3V710	71	0.33
3V750	75	0.35
3V800	80	0.37
3V850	85	0.39
3V900	90	0.42
3V950	95	0.44
3V1000	100	0.46
3V1060	106	0.49
3V1120	112	0.52
3V1180	118	0.55
3V1250	125	0.58
3V1320	132	0.61
3V1400	140	0.70

“3VX” Cogged Belts		
Belt P/N	Outside Length (inch)	Approx. Wt.
3VX250	25	0.10
3VX265	26.5	0.10
3VX280	28	0.11
3VX300	30	0.12
3VX315	31.5	0.12
3VX335	33.5	0.13
3VX355	35.5	0.14
3VX375	37.5	0.15
3VX400	40	0.16
3VX425	42.5	0.17
3VX450	45	0.18
3VX475	47.5	0.19
3VX500	50	0.20
3VX520	52	0.23
3VX530	53	0.21
3VX560	56	0.22
3VX600	60	0.24
3VX630	63	0.25
3VX670	67	0.26
3VX710	71	0.28
3VX750	75	0.30
3VX800	80	0.32
3VX850	85	0.34
3VX900	90	0.36
3VX950	95	0.38
3VX1000	100	0.40
3VX1060	106	0.42
3VX1120	112	0.44
3VX1180	118	0.47
3VX1250	125	0.50
3VX1320	132	0.52
3VX1400	140	0.56

“5V” Belts		
Belt P/N	Outside Length (inch)	Approx. Wt.
5V500	50	0.61
5V530	53	0.65
5V560	56	0.68
5V600	60	0.73
5V630	63	0.77
5V670	67	0.82
5V710	71	0.87
5V750	75	0.92
5V800	80	0.98
5V850	85	1.04
5V900	90	1.10
5V950	95	1.16
5V1000	100	1.23
5V1060	106	1.30
5V1120	112	1.37
5V1180	118	1.45
5V1250	125	1.53
5V1320	132	1.62
5V1400	140	1.80
5V1500	150	1.93
5V1600	160	2.06
5V1700	170	2.19
5V1800	180	2.32
5V1900	190	2.44
5V2000	200	2.57
5V2120	212	2.73
5V2240	224	2.88
5V2360	236	3.04
5V2500	250	3.22
5V2650	265	3.41
5V2800	280	3.60
5V3000	300	3.86
5V3150	315	4.06
5V3350	335	4.31
5V3550	355	4.57

“5VX” Cogged Belts		
Belt P/N	Outside Length (inch)	Approx. Wt.
5VX500	50	0.51
5VX530	53	0.55
5VX560	56	0.58
5VX630	63	0.65
5VX670	67	0.69
5VX710	71	0.73
5VX750	75	0.84
5VX800	80	0.90
5VX850	85	0.96
5VX900	90	1.01
5VX950	95	1.07
5VX1000	100	1.13
5VX1030	103	1.17
5VX1060	106	1.20
5VX1120	112	1.26
5VX1180	118	1.33
5VX1250	125	1.41
5VX1320	132	1.49
5VX1400	140	1.58
5VX1500	150	1.69
5VX1600	160	1.84
5VX1700	170	1.95
5VX1900	190	2.18
5VX2000	200	2.30

“8V” Belts		
Belt P/N	Outside Length (inch)	Approx. Wt.
8V1000	100	3.10
8V1060	106	3.28
8V1120	112	3.47
8V1180	118	3.65
8V1250	125	3.87
8V1320	132	4.09
8V1400	140	4.55
8V1500	150	4.87
8V1600	160	5.20
8V1700	170	5.52
8V1800	180	5.85
8V1900	190	6.17
8V2000	200	6.50
8V2120	212	6.89
8V2240	224	7.28
8V2360	236	7.67
8V2500	250	8.12
8V2800	280	9.06
8V3000	300	9.71
8V3150	315	10.19
8V3350	335	10.84
8V3550	355	11.49
8V3750	375	12.14
8V4000	400	12.95
8V4250	425	13.75

MasterDrive[®] Wedge and Cogged Raw Edge V-Belts **3V Banded Belts**

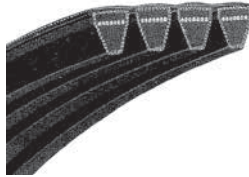

"3V" Banded Belts		
Belt P/N	Outside Length (inch)	Approx. Wt.
2/3V450	45	0.55
3/3V450	45	0.80
4/3V450	45	1.11
5/3V450	45	1.39
3/3V475	47.5	0.85
2/3V500	50	0.61
3/3V500	50	0.89
4/3V500	50	1.23
5/3V500	50	1.54
2/3V530	53	0.65
3/3V530	53	0.95
4/3V530	53	1.30
5/3V530	53	1.63
2/3V560	56	0.69
3/3V560	56	1.00
4/3V560	56	1.38
2/3V600	60	0.74
3/3V600	60	1.07
4/3V600	60	1.48
5/3V600	60	1.85
2/3V630	63	0.77
3/3V630	63	1.12
4/3V630	63	1.55

"3V" Banded Belts		
Belt P/N	Outside Length (inch)	Approx. Wt.
2/3V670	67	0.82
3/3V670	67	1.20
4/3V670	67	1.65
5/3V670	67	2.06
2/3V710	71	0.87
3/3V710	71	1.27
4/3V710	71	1.75
5/3V710	71	2.19
2/3V750	75	0.92
3/3V750	75	1.34
5/3V750	75	2.31
2/3V800	80	0.98
3/3V800	80	1.43
4/3V800	80	1.97
5/3V800	80	2.47
2/3V850	85	1.05
3/3V850	85	1.55
4/3V850	85	2.10
3/3V900	90	1.61
4/3V900	90	2.22
5/3V900	90	2.77
4/3V950	95	2.34
5/3V950	95	2.93

"3V" Banded Belts		
Belt P/N	Outside Length (inch)	Approx. Wt.
3/3V1000	100	1.78
4/3V1000	100	2.47
5/3V1000	100	3.08
4/3V1060	106	2.45
5/3V1060	106	3.07
2/3V1120	112	1.29
3/3V1120	112	2.00
4/3V1120	112	2.59
5/3V1120	112	3.24
2/3V1180	118	1.36
3/3V1180	118	2.11
3/3V1250	125	2.23
4/3V1250	125	2.90
5/3V1250	125	3.62
3/3V1400	140	2.50
4/3V1400	140	3.28

MasterDrive® Wedge and Cogged Raw Edge V-Belts **5V Banded Belts**

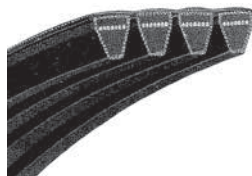

“5V” Banded Belts Outside		
Belt P/N	Length (inch)	Approx. Wt.
2/5V630	63	1.81
3/5V630	63	2.71
4/5V630	63	3.62
5/5V630	63	4.53
2/5V670	67	1.92
3/5V670	67	2.89
4/5V670	67	3.85
5/5V670	67	4.81
2/5V710	71	2.04
3/5V710	71	3.06
4/5V710	71	4.08
5/5V710	71	5.10
2/5V750	75	2.15
3/5V750	75	3.23
4/5V750	75	4.31
5/5V750	75	5.39
2/5V800	80	2.30
3/5V800	80	3.45
4/5V800	80	4.60
5/5V800	80	5.75
2/5V850	85	2.44
3/5V850	85	3.66
4/5V850	85	4.89
5/5V850	85	6.11
2/5V900	90	2.58
3/5V900	90	3.88
4/5V900	90	5.17
5/5V900	90	6.47
2/5V950	95	2.73
3/5V950	95	4.10
4/5V950	95	5.46
5/5V950	95	6.83
2/5V1000	100	2.87
4/5V1000	100	5.75
5/5V1000	100	7.19

“5V” Banded Belts Outside		
Belt P/N	Length (inch)	Approx. Wt.
2/5V1060	106	3.05
3/5V1060	106	4.57
4/5V1060	106	6.10
2/5V1120	112	3.22
3/5V1120	112	4.83
4/5V1120	112	6.44
5/5V1120	112	8.05
2/5V1180	118	3.39
3/5V1180	118	5.09
4/5V1180	118	6.79
5/5V1180	118	8.48
2/5V1250	125	3.58
3/5V1250	125	5.37
4/5V1250	125	7.16
5/5V1250	125	8.95
2/5V1320	132	3.78
3/5V1320	132	5.67
4/5V1320	132	7.56
5/5V1320	132	9.46
2/5V1400	140	4.01
3/5V1400	140	6.02
4/5V1400	140	8.02
2/5V1500	150	4.30
3/5V1500	150	6.45
4/5V1500	150	8.60
5/5V1500	150	10.75
2/5V1600	160	4.58
3/5V1600	160	6.88
4/5V1600	160	9.17
5/5V1600	160	11.46

“5V” Banded Belts Outside		
Belt P/N	Length (inch)	Approx. Wt.
2/5V1700	170	4.87
3/5V1700	170	7.31
4/5V1700	170	9.74
5/5V1700	170	12.18
2/5V1800	180	5.16
3/5V1800	180	7.74
5/5V1800	180	12.90
2/5V1900	190	5.44
3/5V1900	190	8.17
4/5V1900	190	10.89
5/5V1900	190	13.61
2/5V2000	200	5.73
3/5V2000	200	8.60
4/5V2000	200	11.46
5/5V2000	200	14.33
2/5V2120	212	6.07
3/5V2120	212	9.11
4/5V2120	212	12.15
5/5V2120	212	15.19
2/5V2240	240	6.80
3/5V2240	240	10.20
4/5V2240	240	13.60
5/5V2240	240	17.00
2/5V2360	236	7.16
3/5V2360	236	10.75
5/5V2360	236	17.91
3/5V2500	250	11.38
4/5V2500	250	15.18
5/5V2500	250	18.98

“5V” Banded Belts Outside		
Belt P/N	Length (inch)	Approx. Wt.
2/5V2650	265	8.04
3/5V2650	265	12.07
4/5V2650	265	16.09
5/5V2650	265	20.12
2/5V2800	280	8.50
3/5V2800	280	12.75
4/5V2800	280	17.00
2/5V3000	300	9.11
3/5V3000	300	13.66
4/5V3000	300	18.22
5/5V3000	300	22.77
2/5V3150	315	9.56
3/5V3150	315	14.35
4/5V3150	315	19.13
5/5V3150	315	23.91
2/5V3350	335	10.17
3/5V3350	335	15.26
4/5V3350	335	20.34
5/5V3350	335	25.43
2/5V3550	355	10.78
3/5V3550	355	16.17
4/5V3550	355	21.56

MasterDrive[®] Wedge and Cogged Raw Edge V-Belts **5VX Banded Belts**

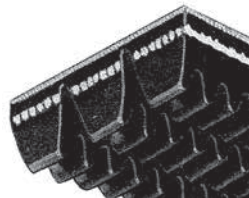

“5VX” Banded Belts		
Belt P/N	Outside Length (inch)	Approx. Wt.
2/5VX1000	100	2.88
3/5VX1000	100	4.32
4/5VX1000	100	5.76
5/5VX1000	100	7.20
2/5VX1060	106	3.05
3/5VX1060	106	4.58
4/5VX1060	106	6.10
5/5VX1060	106	7.63
2/5VX1120	112	3.22
3/5VX1120	112	4.84
4/5VX1120	112	6.45
5/5VX1120	112	8.06
2/5VX1180	118	3.40
3/5VX1180	118	5.10
4/5VX1180	118	6.80
5/5VX1180	118	8.50
2/5VX1250	125	3.60
3/5VX1250	125	5.40
4/5VX1250	125	7.20
5/5VX1250	125	9.00
2/5VX1320	132	3.80
3/5VX1320	132	5.70
4/5VX1320	132	7.60
5/5VX1320	132	9.50
2/5VX1400	140	4.28
3/5VX1400	140	6.43
4/5VX1400	140	8.57
5/5VX1400	140	10.71

“5VX” Banded Belts		
Belt P/N	Outside Length (inch)	Approx. Wt.
2/5VX1500	150	4.59
3/5VX1500	150	6.89
4/5VX1500	150	9.18
5/5VX1500	150	11.48
2/5VX1600	160	4.90
3/5VX1600	160	7.35
4/5VX1600	160	9.80
5/5VX1600	160	12.25
2/5VX1700	170	5.20
3/5VX1700	170	7.80
4/5VX1700	170	10.40
5/5VX1700	170	13.00
2/5VX1800	180	5.50
3/5VX1800	180	8.25
4/5VX1800	180	11.01
5/5VX1800	180	13.76
2/5VX1900	190	5.81
3/5VX1900	190	8.71
4/5VX1900	190	11.62
5/5VX1900	190	14.52
2/5VX2000	200	6.11
3/5VX2000	200	9.17
4/5VX2000	200	12.23
5/5VX2000	200	15.29

MasterDrive[®] Wedge and Cogged Raw Edge V-Belts **8V Banded Belts**

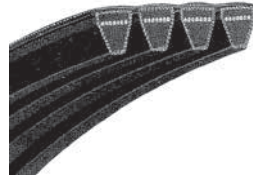

"8V" Banded Belts		
Belt P/N	Outside Length (inch)	Approx. Wt.
3/8V1000	100	11.02
3/8V1060	106	11.69
5/8V1060	106	19.48
3/8V1120	112	12.35
4/8V1120	112	16.47
5/8V1120	112	20.58
3/8V1180	118	13.01
4/8V1180	118	17.35
3/8V1250	125	13.78
4/8V1250	125	18.38
5/8V1250	125	22.97
3/8V1320	132	14.55
4/8V1320	132	19.41
5/8V1320	132	24.26
3/8V1400	140	15.44
4/8V1400	140	20.58
5/8V1400	140	25.73
3/8V1500	150	16.54
4/8V1500	150	22.05
5/8V1500	150	27.57
3/8V1600	160	17.64
4/8V1600	160	23.52
5/8V1600	160	29.41
3/8V1700	170	18.75
4/8V1700	170	25.00
5/8V1700	170	31.25
3/8V1800	180	19.85
4/8V1800	180	26.47
5/8V1800	180	33.08

"8V" Banded Belts		
Belt P/N	Outside Length (inch)	Approx. Wt.
3/8V1900	190	20.59
4/8V1900	190	27.45
5/8V1900	190	34.31
3/8V2000	200	21.67
4/8V2000	200	28.90
3/8V2120	212	22.97
4/8V2120	212	30.63
3/8V2240	224	24.27
4/8V2240	224	32.36
5/8V2240	224	40.46
4/8V2360	236	34.80
5/8V2360	236	43.50
3/8V2500	250	27.65
4/8V2500	250	36.86
5/8V2500	250	46.08
3/8V2650	265	29.30
4/8V2650	265	39.07
5/8V2650	265	48.84
3/8V2800	280	30.96
4/8V2800	280	41.29
5/8V2800	280	51.61
3/8V3000	300	33.18
4/8V3000	300	44.24
5/8V3000	300	55.30
4/8V3150	315	46.45
5/8V3150	315	58.06
3/8V3350	335	37.05
5/8V3350	335	61.75

"8V" Banded Belts		
Belt P/N	Outside Length (inch)	Approx. Wt.
3/8V3550	355	39.26
4/8V3550	355	52.35
5/8V3550	355	65.43
3/8V3750	375	41.47
4/8V3750	375	55.30
5/8V3750	375	69.12
3/8V4000	400	44.24
3/8V4250	425	47.00
4/8V4250	425	62.67
5/8V4250	425	78.34
3/8V4500	450	49.77
4/8V4500	450	66.36
5/8V4500	450	82.95

MasterDrive[®] Aramid Fiber Raw Edge V-Belts **8VK Banded Belts**

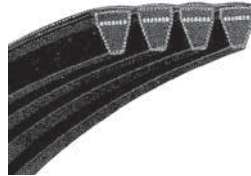

"8VK" Banded Belts			"8VK" Banded Belts			"8VK" Banded Belts			"8VK" Banded Belts		
Belt P/N	Outside Length (inch)	Approx. Wt.	Belt P/N	Outside Length (inch)	Approx. Wt.	Belt P/N	Outside Length (inch)	Approx. Wt.	Belt P/N	Outside Length (inch)	Approx. Wt.
2/8VK1000	100	6.58	2/8VK1700	170	11.18	2/8VK2800	280	18.42	2/8VK4750	475	31.24
3/8VK1000	100	9.87	3/8VK1700	170	16.77	3/8VK2800	280	27.63	3/8VK4750	475	46.86
4/8VK1000	100	13.16	4/8VK1700	170	22.36	4/8VK2800	280	36.84	4/8VK4750	475	62.48
5/8VK1000	100	16.48	5/8VK1700	170	27.95	5/8VK2800	280	46.05	5/8VK4750	475	78.10
2/8VK1060	106	6.98	2/8VK1800	180	11.84	2/8VK3000	300	19.74	2/8VK5000	500	32.90
3/8VK1060	106	10.47	3/8VK1800	180	17.76	3/8VK3000	300	29.61	3/8VK5000	500	49.35
4/8VK1060	106	13.96	4/8VK1800	180	23.68	4/8VK3000	300	39.48	4/8VK5000	500	65.80
5/8VK1060	106	17.45	5/8VK1800	180	29.60	5/8VK3000	300	49.35	5/8VK5000	500	82.25
2/8VK1120	112	7.36	2/8VK1900	190	12.50	2/8VK3150	315	20.72	2/8VK5600	560	36.84
3/8VK1120	112	11.04	3/8VK1900	190	18.75	3/8VK3150	315	31.08	3/8VK5600	560	56.26
4/8VK1120	112	14.72	4/8VK1900	190	25.00	4/8VK3150	315	41.44	4/8VK5600	560	73.68
5/8VK1120	112	18.40	5/8VK1900	190	31.25	5/8VK3150	315	51.80	5/8VK5600	560	92.10
2/8VK1180	118	7.76	2/8VK2000	200	13.16	2/8VK3350	335	22.04	2/8VK5900	590	39.48
3/8VK1180	118	11.64	3/8VK2000	200	19.74	3/8VK3350	335	33.06	3/8VK5900	590	59.22
4/8VK1180	118	15.52	4/8VK2000	200	26.32	4/8VK3350	335	44.08	4/8VK5900	590	78.96
5/8VK1180	118	19.40	5/8VK2000	200	32.90	5/8VK3350	335	55.10	5/8VK5900	590	98.70
2/8VK1250	125	8.22	2/8VK2120	212	13.94	2/8VK3550	355	23.36	2/8VK6000	600	41.44
3/8VK1250	125	12.33	3/8VK2120	212	20.91	3/8VK3550	355	35.04	3/8VK6000	600	62.16
4/8VK1250	125	16.44	4/8VK2120	212	27.88	4/8VK3550	355	46.72	4/8VK6000	600	82.88
5/8VK1250	125	20.55	5/8VK2120	212	34.85	5/8VK3550	355	58.40	5/8VK6000	600	103.60
2/8VK1320	132	8.68	2/8VK2240	224	14.74	2/8VK3750	375	24.66	2/8VK6600	660	43.42
3/8VK1320	132	13.02	3/8VK2240	224	22.11	3/8VK3750	375	36.99	3/8VK6600	660	65.13
4/8VK1320	132	17.36	4/8VK2240	224	29.48	4/8VK3750	375	49.32	4/8VK6600	660	86.84
5/8VK1320	132	21.70	5/8VK2240	224	36.85	5/8VK3750	375	61.65	5/8VK6600	660	108.55
2/8VK1400	140	9.20	2/8VK2360	236	15.52	2/8VK4000	400	26.32			
3/8VK1400	140	13.80	3/8VK2360	236	23.28	3/8VK4000	400	39.48			
4/8VK1400	140	18.40	4/8VK2360	236	31.04	4/8VK4000	400	52.64			
5/8VK1400	140	23.00	5/8VK2360	236	38.80	5/8VK4000	400	65.80			
2/8VK1500	150	9.86	2/8VK2500	250	16.44	2/8VK4250	425	27.96			
3/8VK1500	150	14.79	3/8VK2500	250	24.66	3/8VK4250	425	41.94			
4/8VK1500	150	19.72	4/8VK2500	250	32.88	4/8VK4250	425	55.92			
5/8VK1500	150	24.65	5/8VK2500	250	41.10	5/8VK4250	425	69.90			
2/8VK1600	160	10.52	2/8VK2650	265	17.44	2/8VK4500	450	29.60			
3/8VK1600	160	15.78	3/8VK2650	265	26.16	3/8VK4500	450	44.40			
4/8VK1600	160	21.04	4/8VK2650	265	34.88	4/8VK4500	450	59.20			
5/8VK1600	160	26.30	5/8VK2650	265	43.60	5/8VK4500	450	74.00			

150L075

Belt Pitch Length (inch)x10

Belt Pitch

Belt Width (inch)x100

15"

3/8"

3/4"

600-8M-50

Belt Pitch Length

Belt Pitch

Belt Width

600MM

8MM

50MM

MasterDrive[®] Timing Belts L Pitch

Belt Type	L		
Tooth Pitch	3/8"		
Code (Width)	050 (1/2") 075 (3/4") 100 (1") 150 (1 1/2")		
Size	Product Code	No. of Teeth	Belt Pitch Length (Inches)
	124L	33	12.38
	150L	40	15.00
	165L	44	16.50
	180L	48	18.00
	187L	50	18.75
	210L	56	21.00
	225L	60	22.50
	240L	64	24.00
	255L	68	25.50
	270L	72	27.00
	285L	76	28.50
	300L	80	30.00
	322L	86	32.25
	345L	92	34.50
	360L	96	36.00
	367L	98	36.75
	375L	100	37.50
	390L	104	39.00
	394L	105	39.38
420L	112	42.00	
435L	116	43.50	
450L	120	45.00	
480L	128	48.00	
510L	136	51.00	
540L	144	54.00	
600L	160	60.00	
630L	168	63.00	
934L	249	93.37	

MasterDrive® Timing Belts H Pitch

Belt Type	H			H		
Tooth Pitch	1/2"			1/2"		
Code (Width)	075(3/4") 100 (1") 150 (1 1/2") 200 (2") 300 (3")			075(3/4") 100 (1") 150 (1 1/2") 200 (2") 300 (3")		
Size	Product Code	No. of Teeth	Belt Pitch Length (Inches)	Product Code	No. of Teeth	Belt Pitch Length (Inches)
	240H	48	24.00	600H	120	60.00
	255H	51	25.50	1120H	224	112.00
	270H	54	27.00	1130H	226	113.00
	280H	56	28.00	630H	126	63.00
	300H	60	30.00	650H	130	65.00
	310H	62	31.00	660H	132	66.00
	330H	66	33.00	680H	136	68.00
	360H	72	36.00	700H	140	70.00
	390H	78	39.00	750H	150	75.00
	400H	80	40.00	770H	154	77.00
	410H	82	41.00	800H	160	80.00
	420H	84	42.00	850H	170	85.00
	430H	86	43.00	900H	180	90.00
	450H	90	45.00	950H	190	95.00
	480H	96	48.00	1000H	200	100.00
	510H	102	51.00	1100H	220	110.00
	540H	108	54.00	1250H	250	125.00
560H	112	56.00	1400H	280	140.00	
570H	114	57.00	1700H	340	170.00	

MasterDrive[®] HTD Timing Belts

5M Pitch

Belt Type	5M		
Tooth Pitch	5MM		
Code (Width)	9 (9MM) 15 (15MM) 25 (25MM)		
Size	Product Code	No. of Teeth	Belt Pitch Length (mm)
	180-5M	36	180
	340-5M	68	340
	350-5M	70	350
	400-5M	80	400
	410-5M	82	410
	420-5M	84	420
	450-5M	90	450
	475-5M	95	475
	500-5M	100	500
	520-5M	104	520
	600-5M	120	600
	670-5M	134	670
	740-5M	148	740
	770-5M	154	770
	800-5M	160	800
	835-5M	167	835
	850-5M	170	850
	920-5M	184	920
	950-5M	190	950
	965-5M	193	965
	980-5M	196	980
	1050-5M	210	1050
	1270-5M	254	1270
1420-5M	284	1420	
1690-5M	338	1690	
1800-5M	360	1800	
2000-5M	400	2000	

MasterDrive® HTD Timing Belts 8M Pitch

Belt Type	8M			8M		
Tooth Pitch	8MM			8MM		
Code (Width)	20 (20MM)	30 (30MM)	50 (50MM) 85 (85MM)	20 (20MM)	30 (30MM)	50 (50MM) 85 (85MM)
Size	Product Code	No. of Teeth	Belt Pitch Length (mm)	Product Code	No. of Teeth	Belt Pitch Length (mm)
	536-8M	67	536	1152-8M	144	1152
	560-8M	70	560	1160-8M	145	1160
	592-8M	74	592	1200-8M	150	1200
	600-8M	75	600	1280-8M	160	1280
	624-8M	78	624	1304-8M	163	1304
	632-8M	79	632	1360-8M	170	1360
	640-8M	80	640	1392-8M	174	1392
	656-8M	82	656	1400-8M	175	1400
	680-8M	85	680	1424-8M	178	1424
	720-8M	90	720	1432-8M	179	1432
	760-8M	95	760	1440-8M	180	1440
	776-8M	97	776	1480-8M	185	1480
	800-8M	100	800	1520-8M	190	1520
	840-8M	105	840	1600-8M	200	1600
	856-8M	107	856	1696-8M	212	1696
	880-8M	110	880	1728-8M	216	1728
	896-8M	112	898	1760-8M	220	1760
	912-8M	114	912	1800-8M	225	1800
	920-8M	115	920	1896-8M	237	1896
	936-8M	117	936	1904-8M	238	1904
	960-8M	120	960	1936-8M	242	1936
	968-8M	121	968	2000-8M	250	2000
	1000-8M	125	1000	2080-8M	260	2080
1040-8M	130	1040	2160-8M	270	2160	
1056-8M	132	1056	2240-8M	280	2240	
1064-8M	133	1064	2272-8M	284	2272	
1120-8M	140	1120	2400-8M	300	2400	

MasterDrive[®] HTD Timing Belts

14M Pitch

Belt Type	14M		
Tooth Pitch	14MM		
Code (Width)	40 (40MM) 55 (55MM) 85 (85MM) 115 (115MM)		
Size	Product Code	No. of Teeth	Belt Pitch Length (mm)
	784-14M	56	784
	826-14M	59	826
	924-14M	66	924
	966-14M	69	966
	1148-14M	82	1148
	1190-14M	85	1190
	1344-14M	96	1344
	1400-14M	100	1400
	1512-14M	108	1512
	1540-14M	110	1540
	1568-14M	112	1568
	1610-14M	115	1610
	1638-14M	117	1638
	1652-14M	118	1652
	1680-14M	120	1680
	1736-14M	124	1736
	1778-14M	127	1778
	1890-14M	135	1890
	1932-14M	138	1932
	1946-14M	139	1946
	2002-14M	143	2002
	2100-14M	150	2100
	2198-14M	157	2198
2310-14M	165	2310	
2450-14M	175	2450	

Installation

1. Clean sheaves/pulleys, and remove dust, dirt and oil.
2. Check for worn grooves using sheave gauge.
3. Use correct belt for sheave size
4. Never "roll" or "pry" the belts into the sheave grooves.
Move the driver unit to allow belt to slip on easily.
5. Check alignment. Drive shafts must be parallel.
6. Rotate each sheave to check for wobble or bent drive shaft.
7. Tighten the belt take-up and then run the belt 10 minutes.
Recheck and adjust tension, using tables on reverse.

Warning

When servicing a drive, be certain machinery is SHUT OFF and properly prevented from accidentally starting. Do not wear loose clothing, jewelry, etc. Keep guards on machinery when it is operating.

Rapid Belt Failure

SYMPTOM	CORRECTION
Belt cover wears rapidly	Replace sheaves
Slip burns-shiny sheave grooves	Increase tension
Belt hard and cracked	Heat condition; Ventilate drive; Check tension
Belt sticky or soft	Eliminate oil

Belt Tensioning

STEP 1: After measuring the belt span (see sketch) use a belt tension tester and apply perpendicular force to any ONE of the belts at the span mid-point. Measure the force required to deflect any of the belts 1/64 inch for every inch of span length. EXAMPLE: A 32" span deflection would be 1/64 inch x 32 or 1/2 inch.

Note: When new belts are installed on a drive, the tension will drop rapidly during the first few hours. Thus, for new belts, multiply the maximum deflection force shown in the tensioning tables by 1.33. Check tension frequently during the first 24 hours of operation. Subsequent retensioning should fall between the minimum and maximum forces shown in the tables. STEP 2: Compare Step 1 deflection force reading with range of force in the following tensioning tables. If the force is below the minimum after any adjustment per above note, then the belts are too loose.

If the force is greater than the maximum after any adjustment per above note, then the belts are too tight.

Readjust measured drive tension until the deflection force is between the maximum and minimum values shown in or calculated from the respective tensioning tables.

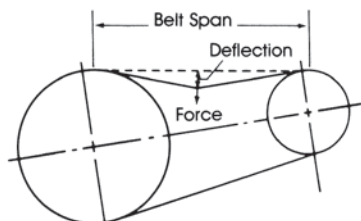

Classical V-Belt Tensioning Table

Belt	Small Sheave Dia. Range (inches)	Small Sheave RPM Range	Speed Ratio Range	Belt Deflection Force in Lbs.			
				Classical		Classical Cogged	
				Min.	Max.	Min.	Max.
A*	2.2	1750 to 3600	2.0 to 4.0	NR	NR	3.8	5.4
	3.2			3.1	4.5	3.9	5.6
	3.4-3.6			3.5	5.0	4.1	5.9
	3.8-4.2			3.8	5.4	4.3	6.3
B*	4.6-7.0	1160 to 1800	2.0 to 4.0	4.6	6.6	4.9	7.1
	4.0			NR	NR	7.1	10
	5.0-5.2			NR	NR	7.3	11
	5.4-5.6			6.0	8.8	7.4	11
C*	6.0-6.8	870 to 1800	2.0 to 4.0	6.6	9.6	7.7	11
	7.4-9.4			7.4	11	7.9	12
	6.8			NR	NR	12	18
	7.5			NR	NR	12	18
D*	8.0-8.5	690 to 1200	2.0 to 4.0	NR	NR	13	18
	9.0-10.5			12	17	13	19
	11.0-16.0			13	20	13	19
	13.0			20	29	-	-
E*	13.5-15.5	435 to 900	2.0 to 4.0	22	33	-	-
	16.0-22.0			25	37	-	-
	21.6			33	48	-	-
	24.0			33	48	-	-

* For Classical banded belts multiply the force in the table by the number of belts in the band.

Narrow V-Belt Tensioning Table

Belt	Small Sheave Dia. Range (inches)	Small Sheave RPM Range	Speed Ratio Range	Belt Deflection Force in Lbs.			
				Narrow		Narrow Cogged	
				Min.	Max.	Min.	Max.
3V*	2.20	1200-3600	2.00 to 4.00	NR	NR	2.8	4.1
	2.35-2.50			NR	NR	3.2	4.7
	2.65-2.80			3.2	4.7	3.5	5.1
	3.00-3.15			3.6	5.3	3.8	5.5
	3.35-3.65			4.1	5.9	4.1	6.0
	4.12-5.00			4.7	6.8	4.8	7.1
5V*	5.30-6.90	1200-3600	2.00 to 4.00	5.2	7.6	5.8	8.6
	4.40-4.65			NR	NR	9.0	13
	4.90-5.50			NR	NR	10	15
	5.90-6.70			NR	NR	11	17
	7.10-8.00			11	17	13	19
	8.50-10.90			13	19	14	20
8V*	11.80-16.00	600-1200	2.00 to 4.00	15	22	15	23
	12.50-17.00			31	45	-	-
	18.00-24.00	400-900		36	53	-	-

NR - Not Recommended

* For Narrow banded belts, multiply the force in the table by the number of belts in the band.

The deflection forces in these tables apply only to the listed belts currently being manufactured.

How to Diagnose V-Belt Failure



Snub Break

Cause

Cover wear indicates slip. Clean break reveals sudden snap.

Prevention

Maintain proper tension on the drive.



Distorted Belt

Cause

Breakdown of adhesion or broken cords.

Prevention

Do not pry belts on drives. Check sheaves for recommended diameters.

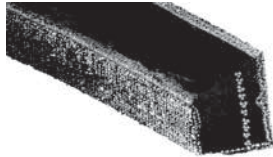

Abrasion

Cause

Foreign material and rust in sheaves wore away sidewalls, letting belt drop to bottom of groove.

Prevention

Dust guards help protect against abrasion. Tension must be maintained in dusty atmospheres.

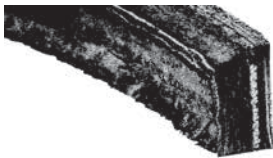

Oil Deterioration

Cause

Oil-softened rubber.

Prevention

Splash guards will protect drives against oil. Although Classical belts are oil resisting, excessive oil can cause some deterioration.



Cover Fabric Rupture

Cause

Cover fabric ruptured when belt was pried over sheave during installation.

Prevention

Proper installation of belts by moving motor so belts do not have to be pried into the grooves.



Slip Burn

Cause

Belt too loose. Belt didn't move, friction against sheave burned rubber. When belt finally grabbed, it snapped.

Prevention

Maintain proper tension on the drive.

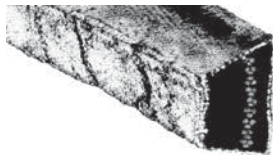

Base Cracking

Cause

Sever back-bend idlers. Improper storage. Excessive ambient operating temperature.

Prevention

Check storage conditions. If back-bend idler cannot be avoided, install idler for larger diameter. Avoid ambient temperature over 140°.

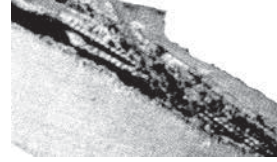

Ply Separation

Cause

Split along pitch line indicating belt ran over too small a sheave.

Prevention

Redesign drive using sheaves of proper size.

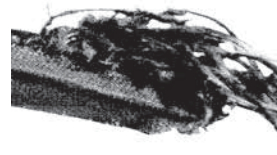

Ruptured

Cause

Ruptured cords in the plies.

Prevention

Check for rocks or tools falling into sheave grooves. Check tension. Belts loose enough to twist in groove can rupture cords.

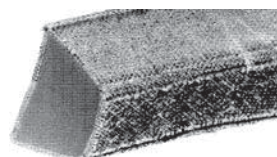

Worn Belt Sides

Cause

Misalignment. Grit or dirt. Normal wear.

Prevention

Align sheaves. Replace belts as required.

V-Belt	Belt Section	Minimum Sheave Pitch Diameter
Classical	A	3"
	B	5.4"
	C	9"
	D	13"
	E	21"
Classical Cogged	AX	2.2"
	BX	4"
	CX	6.8"
Narrow	3V	2.6"
	5V	7.1"
	8V	12.5"
Narrow Cogged	3VX	2.2"
	5VX	4.4"

Safety should be your number one concern.

- * Always turn equipment OFF before installing a belt.
- * Every v-belt should have a proper belt guard.
- * Before installation, check safe speed limits for sheaves.
- * Before installation, lock out the disconnect switch, control valve or the like.
- * Wear gloves when inspecting sheaves to prevent injury from burrs.

<i>Light Duty Sheaves & TB Bushings</i>		<i>Heavy Duty Sheaves</i>	
Description	Product Specifications	Description	Product Specifications
Gray Cast Iron <i>Light Duty</i>	SAE J431 Grade G2500 ASTM Class 25 Gray Iron	Gray Cast Iron <i>Heavy Duty</i>	SAE J431 Grade G3000 ASTM Class 30 Gray Iron
Composition	Typical Base Composition % Carbon 3.30-3.60 Silicon 2.10-2.50 Manganese 0.60-0.90 Sulfur (max ^a)15 Phosphorus (max)20 Approximate Carbon Equivalent ^b 4.10-4.30 ^a = typical value ^b = CE={%C + 1/3% Si.}	Composition	Typical Base Composition % Carbon 3.20-3.50 Silicon 1.90-2.30 Manganese 0.60-0.90 Sulfur (max ^a)15 Phosphorus (max)15 Approximate Carbon Equivalent ^b 3.90-4.20 ^a = typical value ^b = CE={%C + 1/3% Si.}
Mechanical Properties	Typical Values Tensile Strength - P.S.I. 24,500 min. Brinell Hardness - range 170-229	Mechanical Properties	Typical Values Tensile Strength - P.S.I. 29,500 min. Brinell Hardness - range 187-241
Microstructure	Pearlitic - Ferritic	Microstructure	Pearlitic
Primer/Paint	Cast iron sheaves are phosphorated before painting. This is to improve the cohesion between the paint film and the base to effectively keep the metal free from rust. A high quality phosphoric lacquer is used to form a dense and regular gray phosphating film over the iron. Paint Type: Amino Baking Enamel.		
TB Bushings & Jaw Couplings	Phosphorated Only		

OD & DOUBLE SPLIT TAPER BUSHINGS

Description	Product Specifications
Ductile (Nodular) Iron	SAE J434 Grade D4512 ASTM 65-45-12
Composition	Typical Composition Values % Carbon 3.20-4.10 Silicon 1.80-3.00 Manganese 0.10-1.00 Sulfur 0.005-0.035 Phosphorus 0.015-0.10
Mechanical Properties	Typical Values Tensile Strength P.S.I. 65,000 Brinell Hardness range 156-217 Yield Strength, 0.2% offset ..45,000
Microstructure	Pearlitic - Ferritic
Coating	Phosphorated - (Bushings are not painted)
Bolt Grade	Equivalent to SAE Grade 5

Jaw Couplings & H Bushings

Description	Product Specifications
Powdered Metal	FTG70CU-35
Composition	Typical Composition Values % Carbon 0.50-1.10 Copper 0.60-1.50 Silicon ≤0.10 Manganese ≤0.15 Sulfur ≤0.50 Phosphorus ≤0.10
Mechanical Properties	Typical Values Tensile Strength P.S.I. 49,700 Brinell Hardness range >100
Microstructure	Pearlitic - Ferritic
Bolt Grade (Bushings)	Equivalent to SAE Grade 5

All sheaves are statically balanced (sheave is put on a shaft to determine imbalance position & weight then the relevant weight is drilled off.) Dynamic balancing is necessary on certain applications (sheave & bushing are installed on a motor running at the desired RPM requirement and then balanced accordingly. Contact customer service to verify whether dynamic balancing is required.

<i>To Find</i>	<i>Given</i>	<i>Formula</i>	
1. Basic Geometry			
Circumference of a circle	Diameter	Circumference =	3.1416 x diameter
Diameter of a circle	Circumference	Diameter =	Circumference / 3.1416
2. Motion			
Ratio	High Speed & Low Speed	Ratio =	$\frac{\text{RPM High}}{\text{RPM Low}}$
RPM	Feet per Minute of Belt and Pulley Diameter	RPM =	$\frac{\text{FPM}}{.262 \times \text{diameter in inches}}$
Belt Speed Feet per Minute	RPM & Pulley Diameter	FPM =	.262 x RPM x diameter in inches
Ratio	Teeth of Pinion & Teeth of Gear	Ratio =	$\frac{\text{Teeth of Gear}}{\text{Teeth of Pinion}}$
Ratio	Two Sprockets or Pulley Diameters	Ratio =	$\frac{\text{Diameter Driven}}{\text{Diameter Driver}}$
3. Force - Work - Torque			
Force (F)	Torque & Diameter	F =	$\frac{\text{Torque} \times 2}{\text{Diameter}}$
Torque (T)	Force & Diameter	T =	(F x Diameter) / 2
Diameter (Dia.)	Torque & Force	Diameter =	(2 x T) / F
Work	Force & Distance	Work =	Force x Distance
Chain Pull	Torque & Diameter	Pull =	(T x 2) / Diameter
4. Power			
Chain Pull	Horsepower & Speed (FPM)	Pull =	(33,000 x HP) / Speed
Horsepower	Force & Speed (FPM)	HP =	(Force x Speed) / 33,000
Horsepower	RPM & Torque (#in.)	HP =	(Torque x RPM) / 63025
Horsepower	RPM & Torque (#ft.)	HP =	(Torque x RPM) / 5250
Torque	HP & RPM	T #in. =	(63025 x HP) / RPM
Torque	HP & RPM	T #ft. =	(5250 x HP) / RPM
5. Inertia			
Accelerating Torque (#ft.)	WK ² , RMP, Time	T =	$\frac{\text{WK}^2 \times \text{RPM}}{308 \times \text{Time}}$
Accelerating Time (Sec.)	Torque, WK ² , RPM	t =	$\frac{\text{WK}^2 \times \text{RPM}}{308 \times \text{Torque}}$
WK ² at motor	WK ² at Load, Ratio	WK ² Motor =	$\frac{\text{WK}^2}{\text{Ratio}^2}$
6. Gearing			
Gearset Centers	Pd Gear & Pd Pinion	Centers =	(Pd _G + Pd _p) / 2
Pitch Diameter	No. of Teeth & Diametral Pitch	Pd =	Teeth / DP
Pitch Diameter	No. of Teeth & Module	Pd =	(Teeth x Module) / 25.4
Diametral Pitch	Pd & No. of Teeth	DP =	Teeth / Pd
Module	Pd & No. of Teeth	Module =	(Pd x 25.4) / Teeth
Circular Pitch	Pd & No. of Teeth	CP =	(3.1416 x Pd) / Teeth
Circular Pitch	Diametral Pitch	CP =	3.1416 / DP
Number of Teeth	Pd & DP	Teeth =	Pd x DP
Number of Teeth	Pd & Module	Teeth =	(Pd x 25.4) / Module
Tooth Depth	Diametral Pitch	TD =	2.35 / DP
Tooth Depth	Module	TD =	(2.35 x Module) / 25.4

<i>To Find</i>	<i>Given</i>	<i>Formula</i>
7. Belting		
Effective Tension	T_1 and T_2	$T_e = T_1 - T_2$
Effective Tension	HP, RPM, Pulley Radius	$T_e = \frac{63025 \times \text{HP}}{\text{RPM} \times R}$
Effective Tension	Torque, Pulley Radius	$T_e = \text{Torque} / R$
Effective Tension	Horsepower, Belt Velocity (FPM)	$T_e = (\text{HP} \times 33000) / \text{FPM}$
Total Load	T_1 & T_2	$TL = T_1 + T_2$
8. Overhung Load		
Overhung Load	Torque, Diameter	$OHL = (T \times 2) / \text{Diameter}$
Overhung Load	Effective Tension, Belt Factor $f = 1.50$ V-Belts $f = 2.50$ flat belts	$OHL = T_e \times f$
Overhung Load	Horsepower, Speed (RPM) Diameter, factor $f = 1.0$ chain $f = 1.25$ gear drives $f = 1.50$ V-belts $f = 2.50$ flat belts	$OHL = \frac{126000 \times f \times \text{HP}}{\text{Diameter} \times \text{RPM}}$
Overhung Load	Weight	$OHL = \text{Weight}$
9. Electricity		
Motor Speed (RPM)	Number of Poles	$\text{RPM} = \frac{120 \times \text{HZ}}{\text{No. of Poles}}$
Horsepower Single Phase or Direct Current Motor	Volts, Amps, Power factor Efficiency	$\text{HP} = \frac{\text{Volts} \times \text{Amps} \times \text{Pf} \times \text{Eff.}}{746}$
Horsepower 3 Phase Motor	Volts, Amps, Power factor Efficiency	$\text{HP} = \frac{\text{Volts} \times \text{Amps} \times 1.73 \times \text{Pf} \times \text{Eff.}}{746}$
Horsepower	Watts	$\text{HP} = \text{Watts} / 746$
Horsepower	Kilowatts	$\text{HP} = \text{KW} / .746$
Motor Power (Watts), Single Phase	Volts, Amps, Pf, Eff.	$\text{Watts} = \text{V} \times \text{Amps} \times \text{Pf} \times \text{Eff.}$
Motor Power (Watts), 3 Phase	Volts, Amps, Pf, Eff.	$\text{Watts} = 1.73 \times \text{V} \times \text{Amps} \times \text{Pf} \times \text{Eff.}$
10. Temperature		
Degrees Fahrenheit	Degrees Centigrade	$^{\circ}\text{F} = (1.8 \times ^{\circ}\text{C}) + 32$
Degrees Centigrade	Degrees Fahrenheit	$^{\circ}\text{C} = 5/9 (^{\circ}\text{F} - 32)$
11. Metric Conversions		
Inches x 25.4 = Millimeters		Millimeter x .0394 = inches
Pounds x .455 = Kilograms		Kilogram x 2.2 = pounds
U.S. Gallons x 3.785 = Liters		Liter x .264 = U.S. Gallon
Pounds (Force) x 4.448 = Newtons		Newtons x .2246 = Pounds (Force)
Pounds inches x .113 = Newton Meters		Newton Meters x 8.85 = Pound-ins.
Horsepower x .746 = Kilowatts		Kilowatts x 1.34 = Horsepower
Pounds/in ² (psi) x .0069 = Newtons/mm ²		Newton /mm ² x 145 = Pounds/in ²
BTU x .00029 = Kilowatt Hours		Kilowatt Hours x 3415 = BTU's

Engineering Calculations Quick Reference Guide

Torque

$$\text{Horsepower} = \frac{\text{(Torque, Pound-inches) (RPM)}}{63,025}$$

$$\text{Horsepower} = \frac{\text{(Torque, Pound-feet) (RPM)}}{5,252}$$

Flywheel Effect, WR²

$$WR^2 = \frac{0.17773F (D_o^4 - D_i^4)}{1000} - \frac{NY (D_o - Z)^3}{1000} \text{ lb.-ft}^2$$

for gray iron. Multiply by 1.08 for steel.

Where: D_o = Outside diameter of rim, inches.
 D_i = Inside diameter of rim, inches.
 F = Face width of rim, inches
 N = Number of grooves
 Y = Groove constant from table
 Z = Groove constant from table

**Torque Required to Accelerate
or Decelerate a Flywheel**

The torque required to uniformly accelerate or decelerate a sheave, pulley or flywheel can be calculated as follows:

$$\text{Torque (in. lbs.)} = \frac{.03908 \times N \times W \times R^2}{t}$$

$$\text{Torque (ft. lbs.)} = \frac{.003257 \times N \times W \times R^2}{t}$$

N = Difference between initial and final RPM.

W = Weight of rim in pounds.

R = Mean Radius of Sheave Rim, Pulley or Flywheel in feet.

t = Time required to effect speed change, in seconds.

Data for WR² Calculations

Groove	Pitch Diameter	Add to PD to find D _o	Outside Diameter (in)	Outside Diameter (D _o) Minus Inside Diameter (D _i) for Standard Sheaves	Y	Z
3V	-	-	up to 10.6	1.2	.113	.30
	-	-	10.7 to 25.0	1.3	.113	.30
	-	-	25.1 to 35.5	1.5	.113	.30
5V	-	-	up to 21.2	1.9	.320	.50
	-	-	21.2 to 31.5	2.0	.320	.50
	-	-	37.5 to 50.00	2.2	.320	.50
8V	-	-	up to 22.4	2.7	.885	.80
	-	-	22.5 to 53.0	2.9	.885	.80
	-	-	53.1 & up	3.0	.885	.80
A Multi-Duty	All	.75	-	1.6	.377	.50
B Multi-Duty	All	.35	-	1.6	.377	.50
A	All	.25	-	1.5	.238	.40
B	All	.35	-	1.7	.384	.50
C	Up to 18.0	.40	-	2.1	.696	.65
C	20.1 to 50.0	.40	-	2.2	.696	.68
D	Up to 20.0	.60	-	2.9	1.280	.90
D	20.0 to 58.0	.60	-	3.0	1.280	.90
E (Special)		.80	-		2.050	1.14

V-Belt Drive Factors

Arc of Contact Correction Factors G and R

$\frac{D-d}{C}$	Small Sheave Arc of Contact	Factor G	Factor R	$\frac{D-d}{C}$	Small Sheave Arc of Contact	Factor G	Factor R
.00	180°	1.00	1.000	.80	133°	.87	.917
.10	174°	.99	.999	.90	127°	.85	.893
.20	169°	.97	.995	1.00	120°	.82	.866
.30	163°	.96	.989	1.10	113°	.80	.835
.40	157°	.94	.980	1.20	106°	.77	.800
.50	151°	.93	.968	1.30	99°	.73	.760
.60	145°	.91	.954	1.40	91°	.70	.714
.70	139°	.89	.937	1.50	83°	.65	.661

D = Diam. of large sheave
 C = Center distance
 d = Diam. of small sheave

Allowable Sheave Rim Speed

Sheave Material	Rim Speed in Feet per Minute
Cast Iron.....	6,500
Ductile Iron.....	8,000
Steel.....	10,000

NOTE: Above rim speed values are maximum for normal considerations. In some cases, these values may be exceeded. Consult factory and include complete details of proposed application.

Bearing Load Calculations

To find actual loads, it is necessary to know machine component weights and values of all other forces contributing to the load. Sometimes it becomes desirable to know the bearing load imposed by the V-belt drive alone. This can be done if you know bearing spacing with respect to the sheave center and shaft load and apply it to the formula:

Overhung Sheave

$$\text{Load at B, lbs} = \frac{\text{Shaft Load} \times (a+b)}{a}$$

$$\text{Load at A, lbs} = \frac{\text{Shaft load} \times b}{a}$$

Where: a and b = spacing, inches

Short Cut Ways to Figure Pump Drives

- *D = Diameter of pump sheave
- *d = Diameter of engine sheave
- SPM = Strokes Per Minute
- RPM = Engine Speed in Revolutions Per Minute
- R = Gear box ratio
- *C = Shaft center distance
- *Required values to determine belt length

$$\text{Belt length} = \frac{2C + 1.57(D+d) + \frac{(D-d)^2}{4C}}$$

$$D = \frac{\text{RPM} \times d}{\text{SPM} \times R} \quad \text{RPM} = \frac{\text{SPM} \times R \times D}{d}$$

$$d = \frac{\text{SPM} \times R \times D}{\text{RPM}} \quad R = \frac{\text{RPM} \times d}{\text{SPM} \times D}$$

$$\text{SPM} = \frac{\text{RPM} \times d}{R \times D}$$

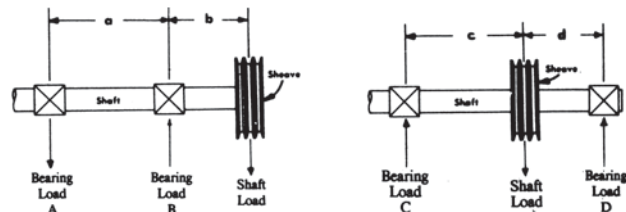

Sheave Between Bearings

$$\text{Load at D, lbs} = \frac{\text{Shaft Load} \times c}{c + d}$$

$$\text{Load at C, lbs} = \frac{\text{Shaft Load} \times d}{c + d}$$

Where: spacing, inches

V-Belt Tension

Belt Effective Pull

$$T_1 - T_2 = 33,000 \left(\frac{HP}{V} \right)$$

Where: T_1 = Tight Side Tension, pounds
 T_2 = Slack Side Tension, pounds
 HP = Design Horsepower
 V = Belt Speed, feet per minute

Total Belt Pull

$$T_1 + T_2 = 33,000 (2.5 - G) \left(\frac{HP}{GV} \right)$$

Where: T_1 = Tight Side Tension, pounds
 T_2 = Slack Side Tension, pounds
 HP = Design Horsepower
 V = Belt Speed, feet per minute
 G = Arc of Contact Correction Factor

Arc Correction Factor

$$G = 1.25 \left(1 - \frac{1}{e^{5123\theta}} \right)$$

Where: θ = arc of contact in radians

Belt Length

$$\text{Belt Length} = 2C + 1.57 (D+d) + \frac{(D-d)^2}{4C}$$

Belt Length = Belt outside diameter
 D = O.D. of large sheave
 d = O.D. of small sheave
 C = center distance between shafts

Belt Speed

$$V = \frac{(PD) (RPM)}{3.82} = (PD) (RPM) (.262)$$

Where: V = Belt Speed, feet per minute
 PD = Pitch Diameter of sheave or pulley
 RPM = Revolutions Per Minute of the same sheave or pulley

Tight Side Tension

$$T_1 = 41,250 \left(\frac{HP}{GV} \right)$$

Where: T_1 = Tight Side Tension, pounds
 HP = Design Horsepower
 V = Belt Speed, feet per minute
 G = Arc of Contact Correction Factor

Slack Side Tension

$$T_2 = 33,000 (1.25 - G) \left(\frac{HP}{GV} \right)$$

Where: T_2 = Slack Side Tension, pounds
 HP = Design Horsepower
 V = Belt Speed, feet per minute
 G = Arc of Contact Correction Factor

ENGINEERING INFORMATION—Torque and Horsepower Equivalents

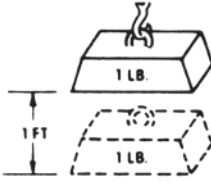

A foot-pound is the amount of energy expended in lifting a one-pound mass a distance of one foot against the pull of gravity.

FOOT-POUNDS INDICATE ENERGY

$$\begin{aligned} \text{Torque (in Pound-inches)} &= \frac{63,025 \times \text{HP}}{\text{RPM}} \\ &= \text{Force} \times \text{Lever Arm (in Inches)} \\ \text{Torque (in Pound-Feet)} &= \frac{5,252 \times \text{HP}}{\text{RPM}} \\ &= \text{Force} \times \text{Lever Arm (in Feet)} \end{aligned}$$

Force = Working Load in Pounds.
FPM = Feet Per Minute.
RPM = Revolutions Per Minute.
Lever Arm = Distance from the Force to the center of rotation in Inches or Feet.

How to Read Torque Tables

The tables on the following pages give the Torque in Pound-Inches for ranges of HP and RPM values.

For fractional HP values move the decimal points to the left in HP and Torque values.

HORSEPOWER

Common Unit of Mechanical power. (HP) One HP is the rate of work required to raise 33,000 pounds one foot in one minute.

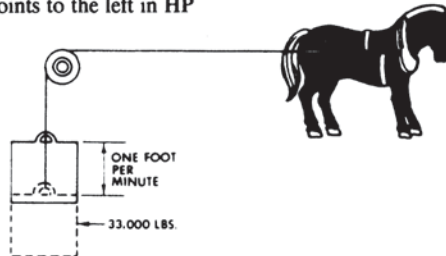

$$\begin{aligned} \text{HP} &= \frac{\text{Force} \times \text{FPM}}{33,000} \\ \text{HP} &= \frac{\text{Torque (in Pound-Inches)} \times \text{RPM}}{63,025} \\ \text{HP} &= \frac{\text{Torque (in Pound-Feet)} \times \text{RPM}}{5,252} \end{aligned}$$

Overhung Loads

An overhung load is a bending force imposed on a shaft due to the torque transmitted by V-drives, chain drives and other power transmission devices, other than flexible couplings.

Most motor and reducer manufacturers list the maximum values allowable for overhung loads. It is desirable that these figures be compared with the load actually imposed by the connected drive.

Overhung loads may be calculated as follows:

$$\text{O.H.L.} = \frac{63,000 \times \text{hp} \times F}{N \times R}$$

Where HP = Transmitted hp \times service factor.
N = RPM of shaft.
R = Radius of sprocket, pulley, etc.
F = Factor.

Weights of the drive components are usually negligible. The formula is based on the assumption that the load is applied at a point equal to one shaft diameter from the bearing face. Factor F depends on the type of drive used:

$$F = \begin{cases} 1.00 & \text{for single chain drives.} \\ 1.10 & \text{for TIMING belt drives.} \\ 1.25 & \text{for spur or helical gear or double-chain drives.} \\ 1.50 & \text{for V-belt drives.} \\ 2.50 & \text{for flat belt drives.} \end{cases}$$

Example: Find the overhung load imposed on a reducer by a double chain drive transmitting 7 hp @ 30 RPM. The pitch diameter of the sprocket is 10"; service factor is 1.3.

Solution:

$$\text{O.H.L.} = \frac{(63,000)(7 \times 1.3)(1.25)}{(30)(5)} = 4,780 \text{ lbs.}$$

Mathematical Equations

To find circumference of a circle, multiply diameter by 3.1416.
To find diameter of a circle multiply circumference by .31831.
To find area of a circle, multiply square of diameter by .7854.
To find area of a rectangle, multiply length by breadth.
To find area of a triangle, multiply base by $\frac{1}{2}$ perpendicular height.
To find area of ellipse, multiply product of both diameters by .7854.
To find area of parallelogram, multiply base by altitude.

To find side of an inscribed square, multiply diameter by 0.7071 or multiply circumference by 0.2251 or divide circumference by 4.4428.
To find side of inscribed cube, multiply radius of sphere by 1.1547.
To find side of an equal square, multiply diameter by .8862.
To find the surface of a sphere, square the diameter and multiply by 3.1416.
To find the volume of a sphere, cube the diameter and multiply by .5236.

A side of a square multiplied by 1.4142 equals diameter of its circumscribing circle.
A side of a square multiplied by 4.443 equals circumference of its circumscribing circle.
A side of a square multiplied by 1.128 equals diameter of an equal circle.
A side of a square multiplied by 3.547 equals circumference of equal circle.
To find gallon capacity of tanks (given dimensions of a cylinder in inches), square the diameter of the cylinder, multiply by the length and by .0034.

TORQUE

It is: a turning moment or twisting effort. Is it expressed in foot-pounds? or pound-feet?

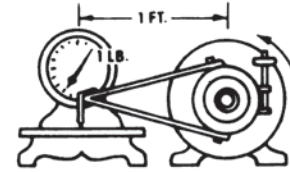

A pound-foot is the moment created by a force of one pound applied to the end of a lever arm one foot long.

POUND-FEET INDICATE TORQUE

Example:

25 HP at 150 RPM = 10504 Pound-Inches Torque
2.5 HP at 150 RPM = 1050.4 Pound-Inches Torque

For other values of RPM move decimal point in RPM values to the left or right as desired, and in Torque values move to the right or left (opposite way) the same number of places.

Example:

25 HP at 150 RPM = 10504 Pound-Inches Torque
25 HP at 1.50 RPM = 1050400 Pound-Inches Torque
2.5 HP at 1.50 RPM = 105040 Pound-Inches Torque

Torque in Pound-inches for Horsepower at Different Revolutions Per Minute

Torque for 1-50 hp @ 100-260 RPM

HP	Revolutions per Minute																
	100	110	120	130	140	150	160	170	180	190	200	210	220	230	240	250	260
1	630	572	525	484	450	420	393	370	350	331	315	300	286	274	262	252	242
2	1260	1145	1050	969	900	840	787	741	700	663	630	600	572	548	525	504	484
3	1890	1718	1575	1454	1350	1260	1181	1112	1050	995	945	900	859	822	787	756	727
4	2521	2291	2100	1939	1800	1680	1575	1482	1400	1326	1260	1200	1145	1096	1050	1008	969
5	3151	2864	2626	2424	2250	2100	1969	1853	1750	1658	1575	1500	1432	1370	1313	1260	1212
6	3781	3437	3151	2908	2701	2521	2363	2224	2100	1990	1890	1800	1718	1644	1575	1512	1454
7	4411	4010	3676	3393	3151	2941	2757	2595	2450	2321	2205	2100	2005	1918	1838	1764	1696
8	5042	4583	4201	3878	3601	3361	3151	2965	2801	2653	2521	2400	2291	2192	2100	2016	1939
9	5672	5156	4726	4363	4051	3781	3545	3336	3151	2985	2836	2701	2578	2466	2363	2268	2181
10	6302	5729	5252	4848	4501	4201	3939	3707	3501	3317	3151	3001	2864	2740	2626	2521	2424
11	6932	6302	5777	5332	4951	4621	4332	4078	3851	3648	3466	3301	3151	3014	2888	2773	2666
12	7563	6875	6302	5817	5402	5042	4726	4448	4201	3980	3781	3601	3437	3288	3151	3025	2908
13	8193	7448	6827	6302	5852	5462	5120	4819	4551	4312	4096	3901	3724	3562	3413	3277	3151
14	8823	8021	7352	6787	6302	5882	5514	5190	4901	4643	4411	4201	4010	3836	3676	3529	3393
15	9453	8594	7878	7272	6752	6302	5908	5561	5252	4975	4726	4501	4297	4110	3939	3781	3636
16	10084	9167	8403	7756	7202	6722	6302	5931	5602	5307	5042	4801	4583	4384	4201	4033	3878
17	10714	9740	8928	8241	7653	7142	6696	6302	5952	5639	5357	5102	4870	4658	4464	4285	4120
18	11344	10313	9453	8726	8103	7563	7090	6673	6302	5970	5672	5402	5156	4932	4726	4537	4363
19	11974	10886	9979	9211	8553	7983	7484	7044	6652	6302	5987	5702	5443	5206	4989	4789	4605
20	12605	11459	10504	9696	9003	8403	7878	7414	7002	6634	6302	6002	5729	5480	5252	5042	4848
21	13235	12032	11029	10181	9453	8823	8272	7785	7352	6965	6617	6302	6016	5754	5514	5294	5090
22	13865	12605	11554	10665	9903	9243	8665	8156	7703	7297	6932	6602	6302	6028	5777	5546	5332
23	14495	13178	12079	11150	10354	9663	9059	8526	8053	7629	7247	6902	6588	6302	6039	5798	5575
24	15126	13750	12605	11635	10804	10084	9453	8897	8403	7961	7563	7202	6875	6576	6302	6050	5817
25	15756	14323	13130	12120	11254	10504	9847	9268	8753	8292	7878	7503	7161	6850	6565	6302	6060
26	16386	14896	13655	12605	11704	10924	10241	9639	9103	8624	8193	7803	7448	7124	6827	6554	6302
27	17016	15469	14180	13089	12154	11344	10635	10009	9453	8956	8508	8103	7734	7398	7090	6806	6544
28	17647	16042	14705	13574	12605	11764	11029	10380	9803	9287	8823	8403	8021	7672	7352	7058	6787
29	18277	16615	15231	14059	13055	12184	11423	10751	10154	9619	9138	8703	8307	7946	7615	7310	7029
30	18907	17188	15756	14544	13505	12605	11817	11122	10504	9951	9453	9003	8594	8220	7878	7563	7272
31	19537	17761	16281	15029	13955	13025	12211	11492	10854	10283	9768	9303	8880	8494	8140	7815	7514
32	20168	18334	16806	15513	14405	13445	12605	11863	11204	10614	10084	9603	9167	8768	8403	8067	7756
33	20798	18907	17331	15998	14855	13865	12998	12234	11554	10946	10399	9903	9453	9042	8665	8319	7999
34	21428	19480	17857	16483	15306	14285	13392	12605	11904	11278	10714	10204	9740	9316	8928	8571	8241
35	22058	20053	18382	16968	15756	14705	13786	12975	12254	11609	11029	10504	10026	9590	9191	8823	8484
36	22689	20626	18907	17453	16206	15126	14180	13346	12605	11941	11344	10804	10313	9864	9453	9075	8726
37	23319	21199	19432	17937	16656	15546	14574	13717	12955	12273	11659	11104	10599	10138	9716	9327	8968
38	23949	21772	19958	18422	17106	15966	14968	14088	13305	12605	11974	11404	10886	10412	9978	9579	9211
39	24579	22345	20483	18907	17557	16386	15362	14458	13655	12936	12289	11704	11172	10686	10241	9831	9453
40	25210	22918	21008	19392	18007	16806	15756	14829	14005	13268	12605	12004	11459	10960	10504	10084	9696
41	25840	23491	21533	19877	18457	17226	16150	15200	14355	13600	12920	12304	11745	11234	10766	10336	9938
42	26470	24064	22058	20362	18907	17647	16544	15570	14705	13931	13235	12605	12032	11508	11029	10588	10181
43	27100	24637	22584	20846	19357	18067	16938	15941	15056	14263	13550	12905	12318	11782	11292	10840	10423
44	27731	25210	23109	21331	19807	18487	17331	16312	15406	14595	13865	13205	12605	12057	11554	11092	10665
45	28361	25783	23634	21816	20258	18907	17725	16683	15756	14927	14180	13505	12891	12331	11817	11344	10908
46	28991	26356	24159	22301	20708	19327	18119	17053	16106	15258	14495	13805	13177	12605	12079	11596	11150
47	29621	26928	24684	22786	21158	19747	18513	17424	16456	15590	14810	14105	13464	12879	12342	11848	11393
48	30252	27501	25210	23270	21608	20168	18907	17795	16806	15922	15126	14405	13750	13153	12605	12100	11635
49	30882	28074	25735	23755	22058	20588	19301	18166	17156	16253	15441	14705	14037	13427	12867	12352	11877
50	31512	28647	26260	24240	22509	21008	19695	18536	17507	16585	15756	15006	14323	13701	13130	12605	12120

Torque in Pound-inches for Horsepower at Different Revolutions Per Minute (Cont.)

Torque for 1-50 hp @ 270-1000 RPM

HP	Revolutions per Minute																	
	270	280	290	300	350	400	450	500	550	600	650	700	750	800	850	900	950	1000
1	233	225	217	210	180	157	140	126	114	105	96	90	84	78	74	70	66	63
2	466	450	434	420	360	315	280	252	229	210	193	180	168	157	148	140	132	126
3	700	675	651	630	540	472	420	378	343	315	290	270	252	236	222	210	199	189
4	933	900	869	840	720	630	560	504	458	420	387	360	336	315	296	280	265	252
5	1167	1125	1086	1050	900	787	700	630	572	525	484	450	420	393	370	350	331	315
6	1400	1350	1303	1260	1080	945	840	756	687	630	581	540	504	472	444	420	398	378
7	1633	1575	1521	1470	1260	1102	980	882	802	735	678	630	588	551	519	490	464	441
8	1867	1800	1738	1680	1440	1260	1120	1008	916	840	775	720	672	630	593	560	530	504
9	2100	2025	1955	1890	1620	1418	1260	1134	1031	945	872	810	756	709	667	630	597	567
10	2334	2250	2173	2100	1800	1575	1400	1260	1145	1050	969	900	840	787	741	700	663	630
11	2567	2475	2390	2310	1980	1733	1540	1386	1260	1155	1066	990	924	866	815	770	729	693
12	2801	2701	2607	2521	2160	1890	1680	1512	1375	1260	1163	1080	1008	945	889	840	796	756
13	3034	2926	2825	2731	2340	2048	1820	1638	1489	1365	1260	1170	1092	1024	963	910	862	819
14	3267	3151	3042	2941	2521	2205	1960	1764	1604	1470	1357	1260	1176	1102	1038	980	928	882
15	3501	3376	3259	3151	2701	2363	2100	1890	1718	1575	1454	1350	1260	1181	1112	1050	995	945
16	3734	3601	3477	3361	2881	2521	2240	2016	1833	1680	1551	1440	1344	1260	1186	1120	1061	1008
17	3968	3826	3694	3571	3061	2678	2380	2142	1948	1785	1648	1530	1428	1339	1260	1190	1127	1071
18	4201	4051	3911	3781	3241	2836	2521	2268	2062	1890	1745	1620	1512	1418	1334	1260	1194	1134
19	4435	4276	4129	3991	3421	2993	2661	2394	2177	1995	1842	1710	1596	1496	1408	1330	1260	1197
20	4668	4501	4346	4201	3601	3151	2801	2521	2291	2100	1939	1800	1680	1575	1482	1400	1326	1260
21	4901	4726	4563	4411	3781	3308	2941	2647	2406	2205	2036	1890	1764	1654	1557	1470	1393	1323
22	5135	4951	4781	4621	3961	3466	3081	2773	2521	2310	2133	1980	1848	1733	1631	1540	1459	1386
23	5368	5177	4998	4831	4141	3623	3221	2899	2635	2415	2230	2070	1932	1811	1705	1610	1525	1449
24	5602	5402	5215	5042	4321	3781	3361	3025	2750	2521	2327	2160	2016	1890	1779	1680	1592	1512
25	5835	5627	5433	5252	4501	3939	3501	3151	2864	2626	2424	2250	2100	1969	1853	1750	1658	1575
26	6069	5852	5650	5462	4681	4096	3641	3277	2979	2731	2521	2340	2184	2048	1927	1820	1724	1638
27	6302	6077	5867	5672	4861	4254	3781	3403	3093	2836	2617	2430	2268	2127	2001	1890	1791	1701
28	6535	6302	6085	5882	5042	4411	3921	3529	3208	2941	2714	2521	2352	2205	2076	1960	1857	1764
29	6769	6527	6302	6092	5222	4569	4061	3655	3323	3046	2811	2611	2436	2284	2150	2030	1923	1827
30	7002	6752	6519	6302	5402	4726	4201	3781	3437	3151	2908	2701	2520	2363	2224	2100	1990	1890
31	7236	6977	6737	6512	5582	4884	4341	3907	3552	3256	3005	2791	2605	2442	2298	2170	2056	1953
32	7469	7202	6954	6722	5762	5042	4481	4033	3666	3361	3102	2881	2689	2520	2372	2240	2122	2016
33	7703	7427	7171	6932	5942	5199	4621	4159	3781	3466	3199	2971	2773	2599	2446	2310	2189	2079
34	7936	7653	7389	7142	6122	5357	4761	4285	3896	3571	3296	3061	2857	2678	2520	2380	2255	2142
35	8169	7878	7606	7352	6302	5514	4901	4411	4010	3676	3393	3151	2941	2757	2595	2450	2321	2205
36	8403	8103	7823	7563	6482	5672	5042	4537	4125	3781	3490	3241	3025	2836	2669	2521	2388	2268
37	8636	8328	8041	7773	6662	5829	5182	4663	4239	3886	3587	3331	3109	2913	2743	2591	2454	2331
38	8870	8553	8258	7983	6842	5987	5322	4789	4354	3991	3684	3421	3193	2993	2817	2661	2520	2394
39	9103	8778	8475	8193	7022	6144	5462	4915	4469	4096	3781	3511	3277	3072	2891	2731	2587	2457
40	9337	9003	8693	8403	7202	6302	5602	5042	4583	4201	3878	3601	3361	3151	2965	2801	2653	2521
41	9570	9228	8910	8613	7382	6460	5742	5168	4698	4306	3975	3691	3445	3230	3040	2871	2720	2584
42	9803	9453	9127	8823	7563	6617	5882	5294	4812	4411	4072	3781	3529	3308	3114	2941	2786	2647
43	10037	9678	9345	9033	7743	6775	6022	5420	4927	4516	4169	3871	3613	3387	3188	3011	2852	2710
44	10270	9903	9562	9243	7923	6932	6162	5546	5042	4621	4266	3961	3697	3466	3262	3081	2919	2773
45	10504	10129	9779	9453	8103	7090	6302	5672	5156	4726	4363	4051	3781	3545	3336	3151	2985	2836
46	10737	10354	9997	9663	8283	7247	6442	5798	5271	4831	4460	4141	3865	3623	3410	3221	3051	2899
47	10971	10579	10214	9873	8463	7405	6582	5924	5385	4936	4557	4231	3949	3702	3484	3291	3118	2962
48	11204	10804	10431	10084	8643	7563	6722	6050	5500	5042	4654	4321	4033	3781	3559	3361	3184	3025
49	11437	11029	10649	10294	8823	7720	6862	6176	5614	5147	4751	4411	4117	3860	3633	3431	3250	3088
50	11671	11254	10866	10504	9003	7878	7002	6302	5729	5252	4848	4501	4201	3939	3707	3501	3317	3151

**Torque in Pound-inches for Horsepower at Different Revolutions Per Minute
(Cont.)**

Torque for 51-100 hp @ 100-260 RPM

HP	Revolutions per Minute																
	100	110	120	130	140	150	160	170	180	190	200	210	220	230	240	250	260
51	32142	29220	26785	24725	22959	21428	20089	18907	17857	16917	16071	15306	14610	13975	13392	12857	12362
52	32773	29793	27310	25210	23409	21848	20483	19278	18207	17249	16386	15606	14896	14249	13655	13109	12605
53	33403	30366	27836	25694	23859	22268	20877	19649	18557	17580	16701	15906	15183	14523	13918	13361	12847
54	34033	30939	28361	26179	24309	22689	21271	20019	18907	17912	17016	16206	15469	14797	14180	13613	13089
55	34663	31512	28886	26664	24759	23109	21664	20390	19257	18244	17331	16506	15756	15071	14443	13865	13332
56	35294	32085	29411	27149	25210	23529	22058	20761	19607	18575	17647	16806	16042	15345	14705	14117	13574
57	35924	32658	29937	27634	25660	23949	22452	21132	19957	18907	17962	17106	16329	15619	14968	14369	13817
58	36554	33231	30462	28118	26110	24369	22846	21502	20308	19239	18277	17406	16615	15893	15231	14621	14059
59	37184	33804	30987	28603	26560	24789	23240	21873	20658	19571	18592	17707	16902	16167	15493	14873	14301
60	37815	34377	31512	29088	27010	25210	23634	22244	21008	19902	18907	18007	17188	16441	15756	15126	14544
61	38445	34950	32037	29573	27461	25630	24028	22614	21358	20234	19222	18307	17475	16715	16018	15378	14786
62	39075	35523	32563	30058	27911	26050	24422	22985	21708	20566	19537	18607	17761	16989	16281	15630	15029
63	39705	36096	33088	30543	28361	26470	24816	23356	22058	20897	19852	18907	18048	17263	16544	15882	15271
64	48336	36669	33613	31027	28811	26890	25210	23727	22408	21229	20168	19207	18334	17537	16806	16134	15513
65	40966	37242	34138	31512	29261	27310	25604	24097	22759	21561	20483	19507	18621	17811	17069	16386	15756
66	41596	37815	34663	31997	29711	27731	25997	24468	23109	21892	20798	19807	18907	18085	17331	16638	15998
67	42226	38388	35189	32482	30162	28151	26391	24839	23459	22224	21113	20108	19194	18359	17594	16890	16241
68	42857	38961	35714	32967	30612	28571	26785	25210	23809	22556	21428	20408	19480	18633	17857	17142	16483
69	43487	39534	36239	33451	31062	28991	27179	25580	24159	22888	21743	20708	19766	18907	18119	17394	16725
70	44117	40106	36764	33936	31512	29411	27573	25951	24509	23219	22058	21008	20053	19181	18382	17647	16968
71	44747	40679	37289	34421	31962	29831	27967	26322	24859	23551	22373	21308	20339	19455	18644	17899	17210
72	45378	41252	37815	34906	32413	30252	28361	26693	25210	23883	22689	21608	20626	19729	18907	18151	17453
73	46008	41825	38340	35391	32863	30672	28755	27063	25560	24214	23004	21908	20912	20003	19170	18403	17695
74	46638	42398	38865	35875	33313	31092	29149	27434	25910	24546	23319	22208	21199	20277	19432	18655	17937
75	47268	42971	39390	36360	33763	31512	29543	27805	26260	24878	23634	22509	21485	20551	19695	18907	18180
76	47899	43544	39916	36845	34213	31932	29937	28176	26610	25210	23949	22809	21772	20825	19957	19159	18422
77	48529	44117	40441	37330	34663	32353	30330	28546	26960	25541	24264	23109	22058	21099	20220	19411	18665
78	49159	44690	40966	37815	35114	32773	30724	28917	27310	25873	24579	23409	22345	21373	20483	19663	18907
79	49789	45263	41491	38299	35564	33193	31118	29288	27661	26205	24894	23709	22631	21647	20745	19915	19149
80	50420	45836	42016	38784	36014	33613	31512	29658	28011	26536	25210	24009	22918	21921	21008	20168	19392
81	51050	46409	42542	39269	36464	34033	31906	30029	28361	26868	25525	24309	23204	22195	21271	20420	19634
82	51680	46982	43067	39754	36914	34453	32300	30400	28711	27200	25840	24609	23491	22469	21533	20672	19877
83	52310	47555	43592	40239	37365	34874	32694	30771	29061	27532	26155	24909	23777	22743	21796	20924	20119
84	52941	48128	44117	40724	37815	35294	33088	31141	29411	27863	26470	25210	24064	23017	22058	21176	20362
85	53571	48701	44642	41208	38265	35714	33482	31512	29761	28195	26785	25510	24350	23291	22321	21428	20604
86	54201	49274	45168	41693	38715	36134	33876	31883	30112	28527	27100	25810	24637	23565	22584	21680	20846
87	54831	49847	45693	42178	39165	36554	34269	32254	30462	28858	27415	26110	24923	23840	22846	21932	21089
88	55462	50420	46218	42663	39615	36974	34663	32624	30812	29190	27731	26410	25210	24114	23109	22184	21331
89	56092	50993	46743	43148	40066	37395	35057	32995	31162	29522	28046	26710	25496	24388	23371	22436	21574
90	56722	51566	47268	43632	40516	37815	35451	33366	31512	29854	28361	27010	25783	24662	23634	22689	21816
91	57352	52139	47794	44117	40966	38235	35845	33737	31862	30185	28676	27310	26069	24936	23897	22941	22058
92	57983	52712	48319	44602	41416	38655	36239	34107	32212	30517	28991	27611	26355	25210	24159	23193	22301
93	58613	53285	48844	45087	41866	39075	36633	34478	32563	30849	29306	27911	26642	25484	24422	23445	22543
94	59243	53857	49369	45572	42317	39495	37027	34849	32913	31180	29621	28211	26928	25758	24684	23697	22786
95	59873	54430	49895	46056	42767	39916	37421	35220	33263	31512	29936	28511	27215	26032	24947	23949	23028
96	60504	55003	50420	46541	43217	40336	37815	35590	33613	31844	30252	28811	27501	26306	25210	24201	23270
97	61134	55576	50945	47026	43667	40756	38209	35961	33963	32176	30567	29111	27788	26580	25472	24453	23513
98	61764	56149	51470	47511	44117	41176	38602	36332	34313	32507	30882	29411	28074	26854	25735	24705	23755
99	62394	56722	51995	47996	44567	41596	38996	36702	34663	32839	31197	29711	28361	27128	25997	24957	23998
100	63025	57295	52521	48481	45018	42016	39390	37073	35014	33171	31512	30012	28647	27402	26260	25210	24240

Torque in Pound-inches for Horsepower at Different Revolutions Per Minute (Cont.)

Torque for 51-100 hp @ 270-1000 RPM

HP	Revolutions per Minute																	
	270	280	290	300	350	400	450	500	550	600	650	700	750	800	850	900	950	1000
51	11904	11479	11083	10714	9183	8035	7141	6428	5844	5357	4945	4591	4285	4017	3781	3571	3383	3214
52	12138	11701	11301	10924	9363	8193	7282	6554	5958	5462	5042	4681	4369	4096	3855	3641	3449	3277
53	12371	11929	11518	11134	9543	8350	7422	6680	6073	5567	5138	4771	4453	4175	3929	3711	3516	3340
54	12605	12154	11735	11344	9723	8508	7563	6806	6187	5672	5235	4861	4537	4254	4003	3781	3582	3403
55	12838	12379	11953	11554	9903	8665	7703	6932	6302	5777	5332	4951	4621	4332	4078	3851	3648	3466
56	13071	12605	12170	11764	10084	8823	7843	7058	6417	5882	5429	5042	4705	4411	4152	3921	3715	3529
57	13305	12830	12387	11974	10264	8981	7983	7184	6531	5987	5526	5132	4789	4490	4226	3991	3781	3592
58	13538	13055	12605	12184	10444	9138	8123	7310	6646	6092	5623	5222	4873	4569	4300	4061	3847	3655
59	13772	13280	12822	12394	10624	9296	8263	7436	6760	6197	5720	5312	4957	4648	4374	4131	3914	3718
60	14005	13505	13039	12605	10804	9453	8403	7563	6875	6302	5817	5402	5041	4726	4448	4201	3980	3781
61	14239	13730	13257	12815	10984	9611	8543	7689	6990	6407	5914	5492	5126	4805	4522	4271	4046	3844
62	14472	13955	13474	13025	11164	9768	8683	7815	7104	6512	6011	5582	5210	4884	4597	4341	4113	3907
63	14705	14180	13691	13235	11344	9926	8823	7941	7219	6617	6108	5672	5294	4963	4671	4411	4179	3970
64	14939	14405	13908	13445	11524	10084	8963	8067	7333	6722	6205	5762	5378	5041	4745	4481	4245	4033
65	15172	14630	14126	13655	11704	10241	9103	8193	7448	6827	6302	5852	5462	5120	4819	4551	4312	4096
66	15406	14855	14343	13865	11884	10399	9243	8319	7563	6932	6399	5942	5546	5199	4893	4621	4378	4159
67	15639	15081	14560	14075	12064	10556	9383	8445	7677	7037	6496	6032	5630	5278	4967	4691	4444	4222
68	15873	15306	14778	14285	12244	10714	9523	8571	7792	7142	6593	6122	5714	5357	5041	4761	4511	4285
69	16106	15531	14995	14495	12424	10871	9663	8697	7906	7247	6690	6212	5798	5435	5116	4831	4577	4348
70	16339	15756	15212	14705	12605	11029	9803	8823	8021	7352	6787	6302	5882	5514	5190	4901	4643	4411
71	16573	15981	15430	14915	12785	11186	9943	8949	8135	7457	6884	6392	5966	5593	5264	4971	4710	4474
72	16806	16206	15647	15126	12965	11344	10084	9075	8250	7563	6981	6482	6050	5672	5338	5042	4776	4537
73	17040	16431	15864	15336	13145	11502	10224	9201	8365	7668	7078	6572	6134	5751	5412	5112	4842	4600
74	17273	16656	16082	15546	13325	11659	10364	9327	8479	7773	7175	6662	6218	5829	5486	5182	4909	4663
75	17507	16881	16299	15756	13505	11817	10504	9453	8594	7878	7272	6752	6302	5908	5561	5252	4975	4726
76	17740	17106	16516	15966	13685	11974	10644	9579	8708	7983	7369	6842	6386	5987	5635	5322	5041	4789
77	17973	17331	16734	16176	13865	12132	10784	9705	8823	8088	7466	6932	6470	6066	5709	5392	5108	4852
78	18207	17557	16951	16386	14045	12289	10924	9831	8938	8193	7563	7022	6554	6144	5783	5462	5174	4915
79	18440	17782	17168	16596	14225	12447	11064	9957	9052	8298	7659	7112	6638	6223	5857	5532	5241	4978
80	18674	18007	17386	16806	14405	12605	11204	10084	9167	8403	7756	7202	6722	6302	5931	5602	5307	5042
81	18907	18232	17603	17016	14585	12762	11344	10210	9281	8508	7853	7292	6806	6381	6005	5672	5373	5105
82	19141	18457	17820	17226	14765	12920	11484	10336	9396	8613	7950	7382	6890	6460	6080	5742	5440	5168
83	19374	18682	18038	17436	14945	13077	11624	10462	9511	8718	8047	7472	6974	6538	6154	5812	5506	5231
84	19607	18907	18255	17647	15126	13235	11764	10588	9625	8823	8144	7563	7058	6617	6228	5882	5572	5294
85	19841	19132	18472	17857	15306	13392	11904	10714	9740	8928	8241	7653	7142	6696	6302	5952	5639	5357
86	20074	19357	18690	18067	15486	13550	12044	10840	9854	9033	8338	7743	7226	6775	6376	6022	5705	5420
87	20308	19582	18907	18277	15666	13707	12184	10966	9969	9138	8435	7833	7310	6853	6450	6092	5771	5483
88	20541	19807	19124	18487	15846	13865	12324	11092	10084	9243	8532	7923	7394	6932	6524	6162	5838	5546
89	20775	20033	19342	18697	16026	14023	12464	11218	10198	9348	8629	8013	7478	7011	6599	6232	5904	5609
90	21008	20258	19559	18907	16206	14180	12605	11344	10313	9453	8726	8103	7562	7090	6673	6302	5970	5672
91	21241	20483	19776	19117	16386	14338	12745	11470	10427	9558	8823	8193	7647	7169	6747	6372	6037	5735
92	21475	20708	19994	19327	16566	14495	12885	11596	10542	9663	8920	8283	7731	7247	6821	6442	6103	5798
93	21708	20933	20211	19537	16746	14653	13025	11722	10656	9768	9017	8373	7815	7326	6895	6512	6169	5861
94	21942	21158	20428	19747	16926	14810	13165	11848	10771	9873	9114	8463	7899	7405	6969	6582	6236	5924
95	22175	21383	20646	19957	17106	14968	13305	11974	10886	9978	9211	8553	7983	7484	7043	6652	6302	5987
96	22408	21608	20863	20168	17286	15126	13445	12100	11000	10084	9308	8643	8067	7562	7118	6722	6368	6050
97	22642	21833	21080	20378	17466	15283	13585	12226	11115	10189	9405	8733	8151	7641	7192	6792	6435	6113
98	22875	22058	21298	20588	17647	15441	13725	12352	11229	10294	9502	8823	8235	7720	7266	6862	6501	6176
99	23109	22283	21515	20798	17827	15598	13865	12478	11344	10399	9599	8913	8319	7799	7340	6932	6567	6239
100	23342	22509	21732	21008	18007	15756	14005	12605	11459	10504	9696	9003	8403	7878	7414	7002	6634	6302

**A-C MOTOR INFORMATION
(NEMA Frame Designation)**

Frame Assignments

HP	Motor Speed, rpm				HP	Motor Speed, rpm			
	3600	1800	1200	900		3600	1800	1200	900
1/8 - 1/2	48	15	215T, 256U	254T, 256U	284T, 324U	286T, 326U
1/8 - 1/2	48	56	20	254T, 284U	256T, 286U	286T, 326U	324T, 364U
1/8	48	25	256T, 286U	284T, 324U	324T, 364U	326T, 365U
1/2 - 1	56	30	284TS, 324S	286T, 326U	326T, 365U	364T, 404U
3/4 - 1	56	40	286TS, 326S	324T, 364U	364T, 404U	365T, 404U
1/2	143T	50	324TS, 364US	326T, 365U, 365US	365T, 405U	404T, 444U
3/4	143T	145T	60	326TS, 365US	364TSΔ, 404U, 404US	404T, 444U	405T, 445U
1	143T	145T	182T	75	364TS, 404US	365TSΔ, 405U, 405US	405T, 445U	444T
1 1/2	143T	145T	182T	184T	100	365TS, 405US	404TSΔ, 444US	444T	445T
2	145T	145T	184T	213T	125	404TS, 444US	405TSΔ, 445US	445T
3	145T	182T	213T	215T, 254U	150	405TS, 445US	444TSΔ
5	182T	184T	215T, 254U	254T, 256U	200	444TS
7 1/2	184T	213T, 254U	254T, 256U	256T, 284U	250	445TS
10	213T, 254U	215T, 256U	256T, 284U	284T, 286U

Motor Frame Dimensions

Frame Size	D	E	2F	H Dia. (4) Holes	U Dia.	BA	V Min.	Key
48	3	2 1/8	2 3/4	1 1/32	1/2	2 1/2	...	3/16 Flat
56	3 1/2	2 7/16	3	1 1/32	5/8	2 3/4	...	3/16 x 3/16 x 1 3/8
143T	3 1/2	2 3/4	4	1 1/32	7/8	2 1/4	2	3/16 x 3/16 x 1 3/8
145T	3 1/2	2 3/4	5	1 1/32	7/8	2 1/4	2	3/16 x 3/16 x 1 3/8
182T	4 1/2	3 3/4	4 1/2	1 3/32	1 1/8	2 3/4	2 1/2	1/4 x 1/4 x 1 3/4
184T	4 1/2	3 3/4	5 1/2	1 3/32	1 1/8	2 3/4	2 1/2	1/4 x 1/4 x 1 3/4
213T	5 1/4	4 1/4	5 1/2	1 3/32	1 3/8	3 1/2	3 1/8	5/16 x 5/16 x 2 3/8
215T	5 1/4	4 1/4	7	1 3/32	1 3/8	3 1/2	3 1/8	5/16 x 5/16 x 2 3/8
254U	6 1/4	5	8 1/4	1 7/32	1 3/8	4 1/4	3 1/2	5/16 x 5/16 x 2 3/4
254T	6 1/4	5	8 1/4	1 7/32	1 5/8	4 1/4	3 3/4	3/8 x 3/8 x 2 7/8
256U	6 1/4	5	10	1 7/32	1 3/8	4 1/4	3 1/2	5/16 x 5/16 x 2 3/4
256T	6 1/4	5	10	1 7/32	1 5/8	4 1/4	3 3/4	3/8 x 3/8 x 2 7/8
284U	7	5 1/2	9 1/2	1 7/32	1 5/8	4 3/4	4 5/8	3/8 x 3/8 x 3 3/4
284T	7	5 1/2	9 1/2	1 7/32	1 7/8	4 3/4	4 3/8	1/2 x 1/2 x 3 1/4
284TS	7	5 1/2	9 1/2	1 7/32	1 5/8	4 3/4	3	3/8 x 3/8 x 1 7/8
286U	7	5 1/2	11	1 7/32	1 5/8	4 3/4	4 5/8	3/8 x 3/8 x 3 3/4
286T	7	5 1/2	11	1 7/32	1 7/8	4 3/4	4 3/8	1/2 x 1/2 x 3 1/4
286TS	7	5 1/2	11	1 7/32	1 5/8	4 3/4	3	3/8 x 3/8 x 1 7/8
324U	8	6 1/4	10 1/2	2 1/32	1 7/8	5 1/4	5 3/8	1/2 x 1/2 x 4 1/4
324T	8	6 1/4	10 1/2	2 1/32	2 1/8	5 1/4	5	1/2 x 1/2 x 3 7/8
324TS	8	6 1/4	10 1/2	2 1/32	1 7/8	5 1/4	3 1/2	1/2 x 1/2 x 2
326U	8	6 1/4	12	2 1/32	1 7/8	5 1/4	5 3/8	1/2 x 1/2 x 4 1/4
326T	8	6 1/4	12	2 1/32	2 1/8	5 1/4	5	1/2 x 1/2 x 3 7/8
326TS	8	6 1/4	12	2 1/32	1 7/8	5 1/4	3 1/2	1/2 x 1/2 x 2
364U	9	7	11 1/4	2 1/32	2 1/8	5 7/8	6 1/8	1/2 x 1/2 x 5
364US	9	7	11 1/4	2 1/32	1 7/8	5 7/8	3 1/2	1/2 x 1/2 x 2
364T	9	7	11 1/4	2 1/32	2 3/8	5 7/8	5 3/8	3/8 x 3/8 x 4 1/4
364TS	9	7	11 1/4	2 1/32	1 7/8	5 7/8	3 1/2	1/2 x 1/2 x 2
365U	9	7	12 1/4	2 1/32	2 1/8	5 7/8	6 1/8	1/2 x 1/2 x 5
365US	9	7	12 1/4	2 1/32	1 7/8	5 7/8	3 1/2	1/2 x 1/2 x 2
365T	9	7	12 1/4	2 1/32	2 3/8	5 7/8	5 3/8	3/8 x 3/8 x 4 1/4
365TS	9	7	12 1/4	2 1/32	1 7/8	5 7/8	3 1/2	1/2 x 1/2 x 2
404U	10	8	12 1/4	1 3/16	2 3/8	6 5/8	6 7/8	5/8 x 5/8 x 5 1/2
404US	10	8	12 1/4	1 3/16	2 1/8	6 5/8	4	1/2 x 1/2 x 2 3/4
404T	10	8	12 1/4	1 3/16	2 7/8	6 5/8	7	3/4 x 3/4 x 5 3/8
404TS	10	8	12 1/4	1 3/16	2 1/8	6 5/8	4	1/2 x 1/2 x 2 3/4
405U	10	8	13 3/4	1 3/16	2 3/8	6 5/8	6 7/8	5/8 x 5/8 x 5 1/2
405US	10	8	13 3/4	1 3/16	2 1/8	6 5/8	4	1/2 x 1/2 x 2 3/4
405T	10	8	13 3/4	1 3/16	2 7/8	6 5/8	7	3/4 x 3/4 x 5 3/8
405TS	10	8	13 3/4	1 3/16	2 1/8	6 5/8	4	1/2 x 1/2 x 2 3/4
444U	11	9	14 1/2	1 3/16	2 7/8	7 1/2	8 3/8	3/4 x 3/4 x 7
444US	11	9	14 1/2	1 3/16	2 1/8	7 1/2	4	1/2 x 1/2 x 2 3/4
444T	11	9	14 1/2	1 3/16	3 3/8	7 1/2	8 1/4	7/8 x 7/8 x 6 7/8
444TS	11	9	14 1/2	1 3/16	2 3/8	7 1/2	4 1/2	5/8 x 5/8 x 3
445U	11	9	16 1/2	1 3/16	2 7/8	7 1/2	8 3/8	3/4 x 3/4 x 7
445US	11	9	16 1/2	1 3/16	2 1/8	7 1/2	4	1/2 x 1/2 x 2 3/4
445T	11	9	16 1/2	1 3/16	3 3/8	7 1/2	8 1/4	7/8 x 7/8 x 6 7/8
445TS	11	9	16 1/2	1 3/16	2 3/8	7 1/2	4 1/2	5/8 x 5/8 x 3

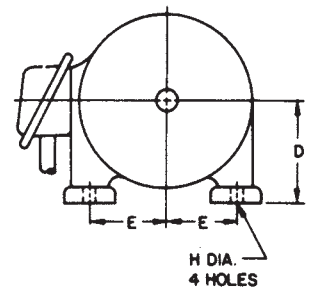
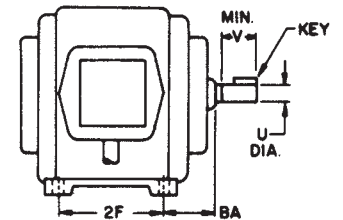

GENERAL ENGINEERING INFORMATION

ENGLISH STANDARD MEASURES

Long Measures

- 1 mile = 1760 yards = 5280 feet
- 1 yard = 3 feet = 36 inches
- 1 foot = 12 inches

Square Measure

- 1 square mile = 640 acres = 6400 square chains
- 1 acre = 10 square chains = 4840 square yards = 43,560 square feet
- 1 square rod = 30.25 square yards = 272.25 square feet = 625 square links
- 1 square yard = 9 square feet
- 1 square foot = 144 square inches
- An acre is equal to a square, the side of which is 208.7 feet

Dry Measure

- 1 bushel (U.S. or Winchester struck bushel) = 1.2445 cubic foot = 2150.42 cubic inches
- 1 bushel = 4 pecks = 42 quarts = 64 pints
- 1 peck = 8 quarts = 16 pints
- 1 quart = 2 pints
- 1 heaped bushel = 1-1/4 struck bushel
- 1 cubic foot = 0.8036 struck bushel
- 1 British Imperial bushel = 8 Imperial gallons = 1.2837 cubic foot = 2218.19 cubic inches

Liquid Measure

- 1 U.S. gallon = 0.1337 cubic foot = 231 cubic inches = 4 quarts = 8 pints
- 1 quart = 2 pints = 8 gills
- 1 pint = 4 gills
- 1 British Imperial gallon = 1.2003 U.S. gallons = 277.27 cubic inches
- 1 cubic foot = 7.48 U.S. gallons
- 1 barrel = 31.5 U.S. gallons

METRIC SYSTEM OF MEASUREMENTS

The principle units are the meter for length, the liter for capacity, and the gram for weight.

The following prefixes are used for sub-divisions and multiples: milli = 1/1000; centi = 1/100; deci = 1/10; deca = 10; hecto = 100; kilo = 1000.

Measure of Length

- 10 millimeters(mm) = 1 centimeter
- 10 centimeters = 1 decimeter(dm)
- 10 decimeters = 1 meter(m)
- 100 meters = 1 kilometer(km)

Measures of Weight

- 10 milligrams(mg) = 1 centigram(cg)
- 10 centigrams = 1 decigram(dg)
- 10 decigrams = 1 gram(g)
- 10 grams = 1 decagram(Dg)
- 10 decagrams = 1 hectogram(Hg)
- 10 hectograms = 1 kilogram(Kg)
- 1000 kilograms = 1 (metric) ton (T)

Square Measure

- 100 sq. millimeters(mm²) = 1 centigram
- 10 sq. centimeters = 1 sq. decimeter(dm²)
- 100 sq. decimeters = 1 sq. meter(m²)

Dry and Liquid Measure

- 10 millimeters(ml) = 1 centiliter(cl)
- 10 centiliters = 1 deciliter(dl)
- 100 liters = 1 hectoliter(Hl)
- 1 liter = 1 cu. decimeter = the volume of 1 Kg of pure water at a temperature of 39.2 degrees F.

Cubic Measure

- 1000 cu. millimeters(mm³) = 1 cu. centimeter(cm³)
- 1000 cu. centimeters = 1 cu. decimeter(dm³)
- 100 cu. decimeters = 1 cu. meter(m³)

Length Conversion Constants for Metric and U.S. Units

- Millimeters x .039370 = inches
- Meters x 39.370 = inches
- Meters x 3.2808 = feet
- Meters x 1.09361 = yards
- Kilometers x 3280.8 feet
- Kilometers x .62137 = statute miles
- Kilometers x .53959 = nautical miles
- Inches x 25.4001 = millimeters
- Inches x .0254 = meters
- Feet x .30480 = meters
- Yards x .91440 = meters
- Feet x .0003048 = kilometers
- Statute miles x 1.60935 kilometers
- Nautical miles x 1.85325 = kilometers

Circular and Angular Measure

- 60 seconds(") = 1 minute (')
- 60 minutes = 1 degree (°)
- 360 degrees = 1 circumference (C)
- 57.3 degrees = 1 radian
- 2 p radians = 1 circumference (C)

Temperature

The following equations are useful for converting temperature from one system to another:

F = degrees Fahrenheit; C = degrees Centigrade

Deg. C = (Deg. F 32) x 5/9

Deg. F = (Deg. C x 9/5) + 32

Avoirdupois or Commercial Weight

- 1 gross or long ton = 2240 pounds
- 1 net or short ton = 2000 pounds
- 1 pound = 16 ounces = 7000 grains
- 1 ounce = 16 drams = 437.5 grains

Cubic Measure

- 1 cubic yard = 27 cubic feet
- 1 cubic foot = 1728 cubic inches
- The following measures are used for wood and masonry:
- 1 cord of wood = 4 x 4 x 8 feet = 128 cubic feet
- 1 perch of masonry = 16-1/2 x 1-1/2 x 1 foot = 24-3/4 cubic feet

Shipping Measure

- For measuring entire internal capacity of a vessel:
- 1 register ton = 100 cubic feet
- For Measurement of Cargo:
- 1 U.S. shipping ton = 40 cubic feet = 32.143 U.S. bushels = 32.16 Imperial bushels
- British shipping ton = 42 cubic feet = 33.75 U.S. bushels = 32.72 Imperial bushels

Weight Conversion Constants for Metric and U.S. Units

- Grams x .981 = dynes
- Grams x 15.432 = grains
- Grams x .03527 = ounces (Avd.)
- Grams x 0.33818 = fluid ounces (water)
- Kilograms x 35.27 ounces (Avd.)
- Kilograms x 2.20462 = pounds (Avd.)
- Metric Tons (1000 Kg)x 1.0231 = Net ton (2000 lbs.)
- Metric tons (1000 Kg) x .98421 = gross tons (2240 lbs)
- Dynes x .0010193 = grams
- Grains x .0648 = grams
- Ounces (Avd.) x 28.35 = grams
- Fluid ounces (Water) x 29.57 = grams
- Ounces (Avd.) x .02835 = kilograms
- Pounds (Avd.) x .45359 = kilograms
- Net ton (2000 lbs) x .90719 = metric tons (1000 Kg)
- Gross ton (2240 lbs)x 1.01605 = Metric tons (1000 Kg)

Area Conversion Constants for Metric and U.S. Units

- Square millimeters x .00155 = sq. inches
- Square centimeters x .155 = sq. inches
- Square meters x 10.76387 = sq. feet
- Square meters x 1.19599 = sq. yards
- Hectares x 2.47104 = acres
- Square kilometers x 247.104 = acres
- Square kilometers x .3861 = sq. miles
- Square inches x 645.163 = sq. millimeters
- Square inches x 6.45163 = sq. centimeters
- Square feet x .0929 = sq. meters
- Square yards x .83613 = square meters
- Acres x .40469 = hectares
- Acres x .0040469 = sq. kilometers
- Square miles x 2.5899 = sq. kilometers

Volume Conversion Constants for Metric and U.S. Units

- Cubic centimeters x .033818 = fluid ounces
- Cubic centimeters x .061023 = cubic inches
- Cubic centimeters x .271 = fluid drams
- Liters x 61.023 = cubic inches
- Liters x 1.05668 = quarts
- Liters x .26417 = gallons
- Liters x .035317 = cubic feet
- Hectoliters x 26.417 = gallons
- Hectoliters x 3.5317 = cubic feet
- Hectoliters x 2.83794 = bushel
- Hectoliters x .1308 cubic yards
- Cubic meters x 264.17 = gallons
- Cubic meters x 35.317 = cubic feet
- Cubic meters x 1.308 = cubic yards
- Fluid ounces x 29.57 = cubic centimeters
- Cubic inches x 16.387 = cubic centimeters
- Fluid drams x 3.69 = cubic centimeters
- Cubic inches x .016387 = liters
- Quarts x .94636 = lites
- Gallons x 3.78543 = liters
- Cubic feet x 28.316 = liters
- Gallons x .0378543 = hectoliters
- Cubic feet x .28316 = hectoliters
- Bushels x .352379 = hectoliters
- Cubic yards x 7.645 hectoliters
- Gallons x .00378543 = cubic meters
- Cubic feet x .028316 = cubic metes
- Cubic yards x .7645 = cubic meters

Power and Heat Conversion Constants for Metric and U.S. Units

Calorie x 0.003968 = B.T.U.

B.T.U. x 252 = calories

Joules x .7373 = foot pounds

Foot pounds x 1.3563 = joules

Kilogram-meters x 7.233 = foot pounds

Foot pounds x 1.3825 = kilogram-meter

Kilowatts x 1.34 = horsepower

Horsepower x .746 = kilowatt

Kilowatt hours x 3415 = B.T.U.

B.T.U. x .00029282 = kilowatt hours

FRACTIONAL/DECIMAL/METRIC EQUIVALENTS

To convert inches to millimeters, multiply the inches by 25.4.
 To convert millimeters to inches, divide the millimeters by 25.4.
 (As established by the American Standards Association.)

inches fractional	decimal	inches fractional	decimal	m/m	inches	m/m	inches	m/m	inches	m/m	inches	m/m	inches	m/m	inches
	1/64 —.0156	33/64 —.5156		1	0.0394	51	2.0079	101	3.9764	151	5.9449	201	7.9134	251	9.8819
	1/32 —.0312	17/32 —.5312		2	0.0787	52	2.0472	102	4.0157	152	5.9843	202	7.9527	252	9.9212
		35/64 —.5469		3	0.1181	53	2.0866	103	4.0551	153	6.0236	203	7.9921	253	9.9606
	3/64 —.0469			4	0.1575	54	2.1260	104	4.0945	154	6.0630	204	8.0315	254	10.0000
1/16	— .0625	9/16	— .5625	5	0.1969	55	2.1654	105	4.1339	155	6.1024	205	8.0709	255	10.0394
	5/64 —.0781	37/64 —.5781		6	0.2362	56	2.2047	106	4.1732	156	6.1417	206	8.1102	256	10.0787
				7	0.2756	57	2.2441	107	4.2126	157	6.1811	207	8.1496	257	10.1181
	3/32 —.0938	19/32 —.5938		8	0.3150	58	2.2835	108	4.2520	158	6.2205	208	8.1890	258	10.1575
	7/64 —.1094	39/64 —.6094		9	0.3543	59	2.3228	109	4.2913	159	6.2598	209	8.2283	259	10.1968
		5/8	— .6250	10	0.3937	60	2.3622	110	4.3307	160	6.2992	210	8.2677	260	10.2362
1/8	— .1250			11	0.4331	61	2.4016	111	4.3701	161	6.3386	211	8.3071	261	10.2756
	9/64 —.1406	41/64 —.6406		12	0.4724	62	2.4409	112	4.4094	162	6.3780	212	8.3464	262	10.3149
	5/32 —.1562	21/32 —.6562		13	0.5118	63	2.4803	113	4.4488	163	6.4173	213	8.3858	263	10.3543
				14	0.5512	64	2.5197	114	4.4882	164	6.4567	214	8.4252	264	10.3937
	11/64 —.1719	43/64 —.6719		15	0.5906	65	2.5591	115	4.5276	165	6.4961	215	8.4646	265	10.4331
3/16	— .1875	11/16	— .6875	16	0.6299	66	2.5984	116	4.5669	166	6.5354	216	8.5039	266	10.4724
		45/64 —.7031		17	0.6693	67	2.6378	117	4.6063	167	6.5748	217	8.5433	267	10.5118
	13/64 —.2031			18	0.7087	68	2.6772	118	4.6457	168	6.6142	218	8.5827	268	10.5512
	7/32 —.2188	23/32 —.7188		19	0.7480	69	2.7165	119	4.6850	169	6.6535	219	8.6220	269	10.5905
	15/64 —.2344	47/64 —.7344		20	0.7874	70	2.7559	120	4.7244	170	6.6929	220	8.6614	270	10.6299
1/4	— .2500			21	0.8268	71	2.7953	121	4.7638	171	6.7323	221	8.7008	271	10.6693
	17/64 —.2656	25/32 —.7812		22	0.8661	72	2.8346	122	4.8031	172	6.7717	222	8.7401	272	10.7086
				23	0.9055	73	2.8740	123	4.8425	173	6.8110	223	8.7795	273	10.7480
	9/32 —.2812	49/64 —.7656		24	0.9449	74	2.9134	124	4.8819	174	6.8504	224	8.8189	274	10.7874
	19/64 —.2969	25/32 —.7812		25	0.9843	75	2.9528	125	4.9213	175	6.8898	225	8.8583	275	10.8268
5/16	— .3125	13/16	— .8125	26	1.0236	76	2.9921	126	4.9606	176	6.9291	226	8.8976	276	10.8661
		51/64 —.7969		27	1.0630	77	3.0315	127	5.0000	177	6.9685	227	8.9370	277	10.9055
	21/64 —.3281			28	1.1024	78	3.0709	128	5.0394	178	7.0079	228	8.9764	278	10.9449
	11/32 —.3438	53/64 —.8281		29	1.1417	79	3.1102	129	5.0787	179	7.0472	229	9.0157	279	10.9842
		27/32 —.8438		30	1.1811	80	3.1496	130	5.1181	180	7.0866	230	9.0551	280	11.0236
	23/64 —.3594	55/64 —.8594		31	1.2205	81	3.1890	131	5.1575	181	7.1260	231	9.0945	281	11.0630
3/8	— .3750			32	1.2598	82	3.2283	132	5.1969	182	7.1654	232	9.1338	282	11.1023
	25/64 —.3906	7/8	— .8750	33	1.2992	83	3.2677	133	5.2362	183	7.2047	233	9.1732	283	11.1417
		57/64 —.8906		34	1.3386	84	3.3071	134	5.2756	184	7.2441	234	9.2126	284	11.1811
	13/32 —.4062			35	1.3780	85	3.3465	135	5.3150	185	7.2835	235	9.2520	285	11.2205
	27/64 —.4219	29/32 —.9062		36	1.4173	86	3.3858	136	5.3543	186	7.3228	236	9.2913	286	11.2598
		59/64 —.9219		37	1.4567	87	3.4252	137	5.3937	187	7.3622	237	9.3307	287	11.2992
	7/16 —.4375	15/16	— .9375	38	1.4961	88	3.4646	138	5.4331	188	7.4016	238	9.3701	288	11.3386
	29/64 —.4531			39	1.5354	89	3.5039	139	5.4724	189	7.4409	239	9.4094	289	11.3779
	15/32 —.4688	61/64 —.9531		40	1.5748	90	3.5433	140	5.5118	190	7.4803	240	9.4488	290	11.4173
1/2	— .5000	31/32 —.9688		41	1.6142	91	3.5827	141	5.5512	191	7.5197	241	9.4882	291	11.4567
		63/64 —.9844		42	1.6535	92	3.6220	142	5.5906	192	7.5591	242	9.5275	292	11.4960
		1	— 1.0000	43	1.6929	93	3.6614	143	5.6299	193	7.5984	243	9.5669	293	11.5354
				44	1.7323	94	3.7008	144	5.6693	194	7.6378	244	9.6063	294	11.5748
				45	1.7717	95	3.7402	145	5.7087	195	7.6772	245	9.6457	295	11.6142
				46	1.8110	96	3.7795	146	5.7480	196	7.7165	246	9.6850	296	11.6535
				47	1.8504	97	3.8189	147	5.7874	197	7.7559	247	9.7244	297	11.6929
				48	1.8898	98	3.8583	148	5.8268	198	7.7953	248	9.7638	298	11.7323
				49	1.9291	99	3.8976	149	5.8661	199	7.8346	249	9.8031	299	11.7716
				50	1.9685	100	3.9370	150	5.9055	200	7.8740	250	9.8425	300	11.8110

