

CONVEYOR COMPONENTS



PULLEYS | LAGGING | IDLERS | IMPACT BEDS
MAGNETIC SEPARATORS | TAKE-UPS

DOUGLAS®



SINCE 1978

Drum Pulleys

All Douglas drum pulleys feature our exclusive single piece rolled rim, solid steel pipe or tubing design that ensures long-life, durability and helps ensure proper belt tracking.

One piece solid steel rims and end discs (see diagram below) are welded into a single assembly using the most precise welding methods available to ensure the maximum level of strength and durability.

Rubber lagging is applied in our plant using a state of the art autoclave for maximum bond and total quality control.

Six classes available to suit your specific needs:

Heavy Duty

Mine Duty

Pulp and Paper Mill Duty™

Quarry Duty

Extreme Duty

True Engineered Class

Integral End Discs Available in All Classes

Bucket Elevator Pulleys

XT style hubs and bushings are standard

Keyless Locking Elements Optional

Stainless steel hubs and bushings in XT Style

Lagging styles include:

- Standard Lagging in plain, herringbone/chevron, diamond, spiral or with machined finishes
- Ceramic Lagging for increased lagging life and more traction
- Replaceable Rim Lagging®

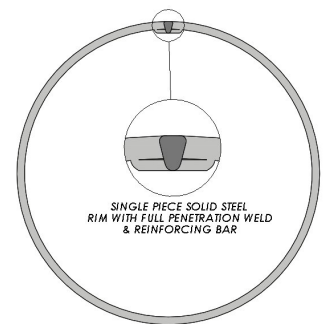
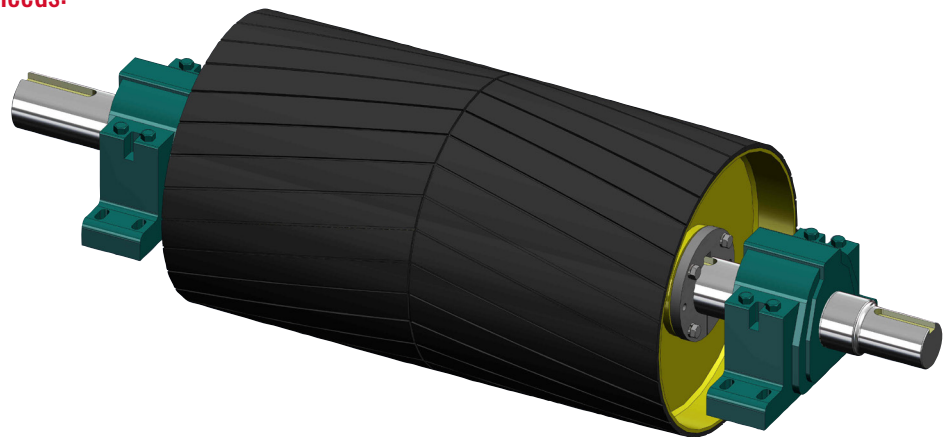

Wing Pulleys

The engineered angle of our gussets creates the optimum angle to discharge material away from the pulley and belt and offers enhanced self cleaning ability over other designs.

Six classes available to suit your specific needs:

- | | |
|---------------------------|-----------------------|
| Heavy Duty | Quarry Duty |
| Mine Duty | Extreme Duty |
| Pulp and Paper Mill Duty™ | True Engineered Class |
| Bucket Elevator Pulleys | |

Round Bar Better by Design

- Full 3/4" Thick Minimum Round Contact Bar Can Last 3X Longer
- Helps Prevent Wing Folding
- Round Bar Protects Belt Bottom Cover from Cuts and Tears
- Round Bar Increases Belt Fastener Life
- Self Cleaning Design Discharges Material Helping to Prevent Build Up
- Optional Wing Reinforcing Rings Available
- Spiral Wing Pulleys Available

Contact Bar Comparison

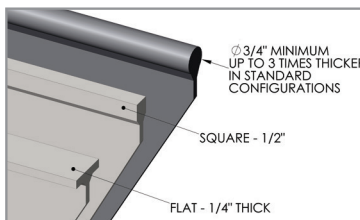

Douglas Solid 3/4" Steel Round Bar Wing Tips Wear Longer and Retain Roundness.

Wears twice as long as other manufacturers flat bar or 1/4" round

Protects underside of belt from cuts, smoother running

Large pulley are fitted with 1" solid steel bars for long life

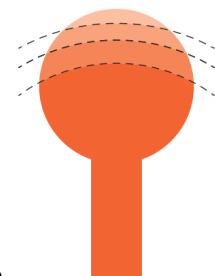

Vortex® Spiral Clean Pulley

US Patents 10,124,964 B2 and D838428

The Vortex® Spiral Clean Pulley is a new and innovative concept in self-cleaning pulley design. The innovative and patented design is for harsh operating conditions and for those applications where uninterrupted operation is a must.

Design Features

- More efficient self-cleaning ability than standard wing pulleys.
- Smoother running, reduced vibration, improved sealing at transfer points and less noise.
- Spiral design aids belt tracking and moves the belt gently toward the middle of the pulley.
- Unique continuous flight design with continuous welds prevents wing folding.
- Plow design moves material to the edge of the pulley and discharges it away from critical areas.
- Abrasion Resistant center and edge support is standard.
- XT style bushings standard. Keyless locking elements are also available options.
- Replaceable Rim Lagging®

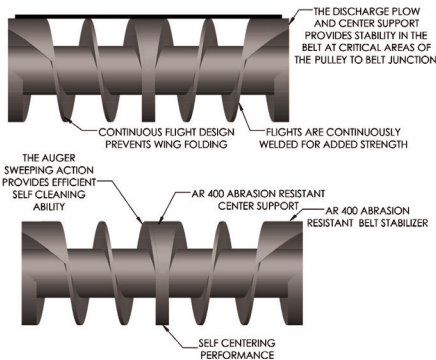

VORTEX® SPIRAL CLEAN PULLEY SECTION CHART						
Available Diameter	12	14	16	18	20	24
Standard Face Widths	26	32	38	44	51	63

Other sizes available on request.



Additional Pulley Systems

Integra™ Series Drum & Wing Pulleys

Integral Bearing Pulleys Offer Many Performance Benefits

- May be used in all non-drive applications
- Available in drum, self cleaning wing and Vortex™ styles
- Available in Mine Duty & Extreme Duty™ Series
- Integral End disk eliminates chance of hub weld failure
- Piloted flanged bearing design simple to install, maintain & repair
- Sealed for life bearings equal less maintenance
- “Off the Shelf” bearing availability reduces down time and cost
- Up to 33% higher load ratings as a result of reduced bearing centers



Spiral Wing Pulleys

Helically wound flat bar, wrapped over self-cleaning wings, creates continuous belt contact, smooths vibration and reduces the level of noise and amount of vibration, improves sealing at transfer points.

- Less noise.
- Less vibration
- Continuous belt contact.
- XT style bushings standard. Keyless locking elements optional.



Ceramic Pulley Lagging

Douglas® Ceramic Pulley Lagging delivers substantially increased traction over conventional pulley lagging. Lagging compound features unique Kevlar® enhanced rubber formulation resulting in a tougher, longer lasting product. Durable ceramic tiles last longer than standard rubber lagging resulting in a reduction in the number of times the pulley must be changed over the life of the conveyor system. The ceramic tiles are bonded to the rubber on all four sides as well as the bottom.

- As much as twice the coefficient of friction over non lagged pulleys
- As much as 50% higher coefficient of friction over standard rubber lagging
- 38% ceramic contact surface with the belt (Medium Duty)
- Virtually eliminates belt slippage
- Improves belt tracking
- Easily sheds water and dirt
- Lower belt tension and less take-up weight increases life of components and belt



Vulcanized Pulley Lagging

Douglas® Truck Tire Tuff™ Conveyor Pulley Lagging delivers increased traction and pulley life over non lagged pulleys. Increased traction between the pulley face and the belt bottom cover reduces belt slippage and helps to improve belt tracking. Vulcanized rubber lagging protects the pulley's face from wear and extends pulley service life. Lagging is applied in our plant for total quality control. We also relag and recondition old pulleys making them look and perform like new.

- As much as 50% increase in coefficient of friction over non lagged pulleys
- Protects pulley face from wear and extends pulley service life
- Herringbone and Diamond Grooves shed water and dirt promoting a self-cleaning effect
- Improves Belt Tracking



Standard Thicknesses	Standard Grooving Patterns	Standard Material	Standard Durometer	Special Durometers	Special Materials
1/4", 3/8", 1/2", 3/4"	Plain Wrap Impression*, Herringbone**, Diamond	SBR	60-65 Shore A	40, 80	MSHA, Nitrile, Neoprene, EPDM, SCOF, Tan Neoprene



Replaceable Rim Lagging®

Replaceable Rim Lagging® is an innovative way to cover new pulleys and recover old pulleys. Engineered sections are made for specific pulleys and effectively cover the pulley face in a protective shell of rubber and steel and are an ideal way to save money and time.



Design Features

- Up to 70% labor savings on installation.
- 30% more coverage resulting in increased traction
- 3/16" solid steel backing plate.
- Vulcanized in house using state of the art computer controlled autoclave.
- 1/2" 60-65 Durometer SBR compound suitable for a wide variety of applications.
- The ability to re-lag the pulley in the field without removing it from the conveyor.
- ROLLED CROWN FACE standard.
- Diamond grooving is standard making installation fast and easy.
- Fewer sections means less gaps and more rubber coverage.
- No excess or wasted material. No undesirable seams.
- Bolt-on option available.
- Ceramic Lagging available.

Quick Comparison Replaceable Rim Lagging vs. Other

PULLEY SIZE	REPLACEABLE RIM LAGGING	OTHER
20X51	4 Pieces/4 Rows	8 Pieces/10 Rows
24X38	4 Pieces/4 Rows	7 Pieces/12 Rows
36X44	5 Pieces/5 Rows	15 Pieces/18 Rows

Detailed Comparison Replaceable Rim Lagging vs. Other

	REPLACEABLE RIM LAGGING	OTHER LAGGING SYSTEMS
Number of Pieces	3	4
Thickness of Rubber	1/2"	1/2"
Thickness of Steel	3/16"	1/16" (.0625)
Crown Face or Flat Face	Option of both	Option of both
Layout, Measuring and Sawing	None	Yes estimated at 3-4 hours
Number of Welds	20 X 1" tack welds estimated to take 1-2 hours	84 tack welds estimated to take as much as 3 hours
Total Estimated Time for Installation	1-2 hours*	6+ hours*

* Note that the time reflected is for installing RRL and Slide Lagging in a new application. Additional time will be needed to clean pulleys that are already lagged i.e. for field installation.

Number of Sections

REPLACEABLE RIM LAGGING® SECTION CHART										
Diameter	12	14	16	18	20	24	30	36	42	48
Weight P.I.W.	2.09	2.44	2.8	3.48	3.63	4.18	5.23	6.28	7.33	8.37
# of Segments Required	3	3	4	4	4	4	4	5	5	5

CEMA B, C, D & E Idlers

Douglas® manufactured Idlers are engineered for demanding CEMA B, C, D or E applications. Douglas idlers are available in a wide variety of configurations including: troughing, return, impact, rubber disc return, self aligning trough, self aligning return, scale quality and live shaft.

Douglas idlers feature:

- Deep drawn steel end cap with metal outer seal provides excellent durability and protection
- Exclusive Triple Lip Polyurethane Contact Seal helps prevent bearing contamination
- The optional Defender™ Polymer Flinger helps prevent material buildup between the end of the roll and the frame as well as helps provide additional sealing in wet and corrosive applications
- CNC Machined, shouldered shaft helps ensure proper bearing alignment
- Rigid, self cleaning, welded steel frame with interchangeable mounting slots
- Reduced friction levels help conserve energy
- Meets or exceeds CEMA B, C, D & E idler ratings

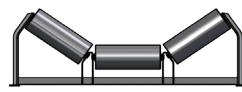

Equal Troughing



Unequal Troughing



Feeder / Picking



Channel Mount Low Profile

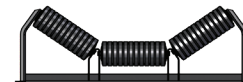

Impact Troughing

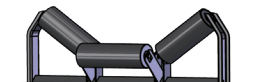

Offset Center Roll Troughing

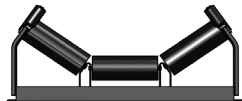

Self-Aligning Troughing

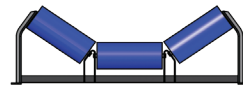

Equal Troughing With Spun Urethane Coating



2-Roll Troughing

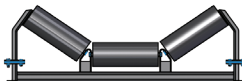

Scale Quality Troughing



Self-Aligning Return



Live Shaft Rubber Disc



Live Shaft Steel



Squirrel Cage Rolls



Flat Carrying Idler



Rubber Disc Flat Idler



Rubber Disc Return



Negotiator Self-Aligning Return



V-Return



Beater Rolls



Channel Inset Return



Channel Inset Rubber Disc Return



Return



Return With Spun Urethane Coating

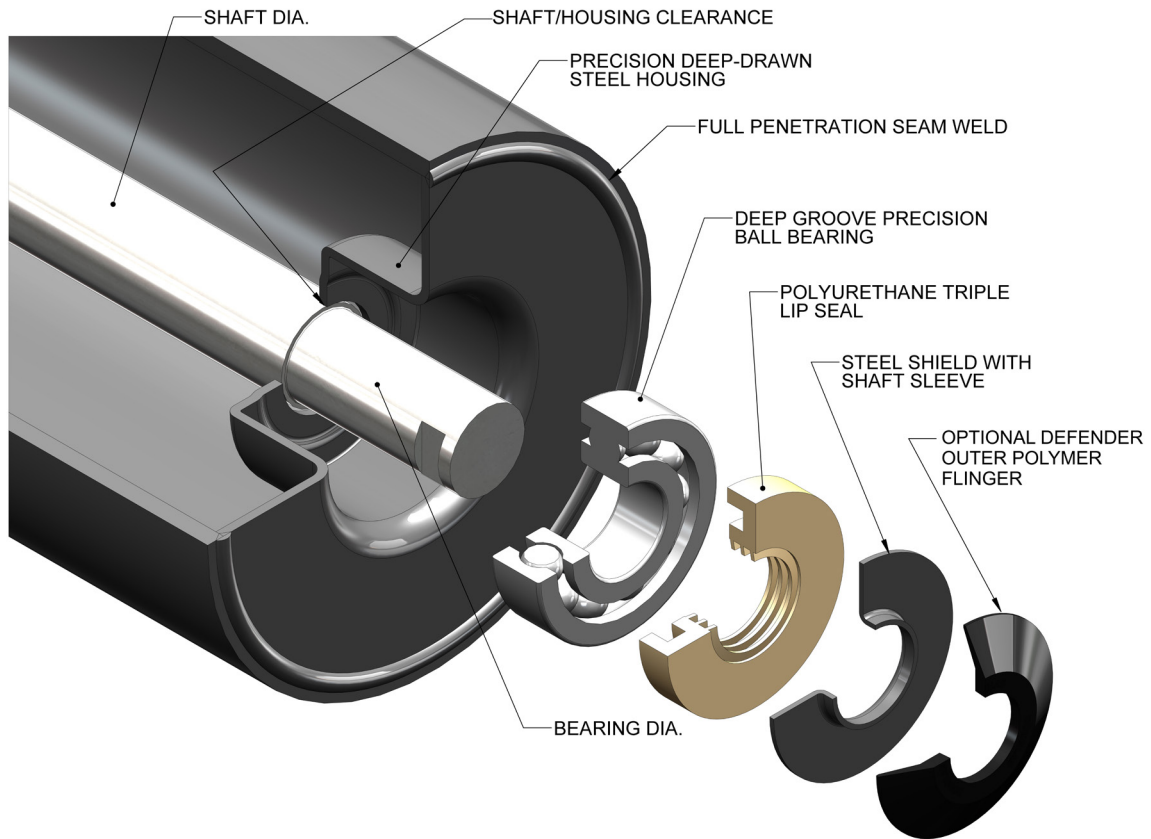

Idler Features

- 1** Foot Bracket - open design allows for single or double bolt hole mounting
- 2** Self-cleaning base angle design
- 3** Die formed End Brackets provide clearance preventing material from being trapped between roll and end bracket
- 4** Bearing housings are welded 100% within the tubing O.D. (Welds do not contact the conveyor belt)
- 5** Retainer clip holds rolls within the frame and offers easy roll removal
- 6** Narrow roll gaps protect belt from excessive wear
- 7** 50ksi Steel used in idler frames
Lighter Weight and 50% Stronger than A36

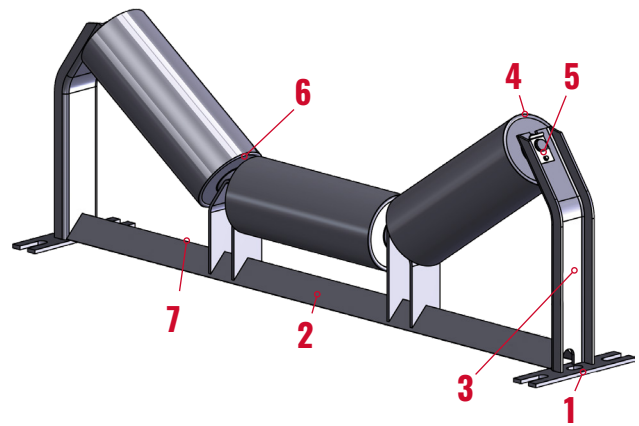

IDLER SPECIFICATIONS					
Class	Bearing Dia.	Shaft Dia.	Roll Dia.	Roll Thickness	Belt Width
CEMA-B	20mm	0.88"	4" & 5"	11 Ga	18" - 48"
CEMA-C	20mm	0.88"	4", 5", & 6"	11 Ga	18" - 60"
CEMA-D	25mm	1.19"	5" & 6"	9 Ga & 8 Ga	24" - 72"
CEMA-E	30mm	1.31"	6" & 7"	3/16" & 1/4"	36" - 96"



Magnetic Separators & Pulleys

Douglas® magnetic separators are for use in helping separate tramp ferrous metals from conveyed material and are suspended above the belt. Magnetic pulleys are manufactured to CEMA standards and can be used in most any head pulley application.

CEMA Class Permanent Magnetic Head Pulleys (PMG)

- Meets or exceeds CEMA/ANSI specifications
- Exclusive One Piece Rolled in Crown ensures consistent, proper belt tracking and tighter tolerances
- Remove potentially harmful tramp ferrous metal before it damages expensive processing equipment
- Crown face pulleys are furnished standard, flat face must be specified
- Douglas hubs and bushings are interchangeable with XT® style
- Stainless Steel Rim standard on all permanent magnetic pulleys

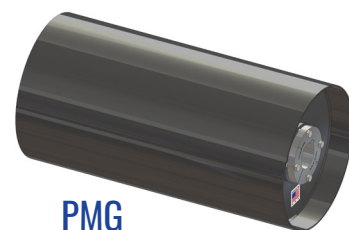

PMG

Self Cleaning Permanent Magnetic Separator (CBM - Standard Power or CBX - Super Power)

- Automatically discharges tramp metal away from the conveyor
- Heavy grade structural steel frame complete with CEMA class lagged crown face head pulley, tail pulley and Slide Tube® belt take-ups
- Heavy duty rubber cover belt standard with hot vulcanized cleats
- Shipped complete, factory test run and ready for installation
- CLASS II shaft mount gear drive with TEFC motor

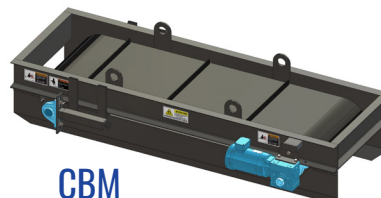

CBM

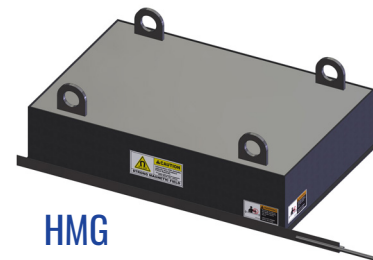

HMG

Standard Manual Cleaning Permanent Magnetic Separators (HMG - Standard Power or XMG - Super Power)

- Manual cleaning of ferrous metal required
- Pivot arm or cleaning drawer available for easy cleaning
- Shipped complete and ready for installation

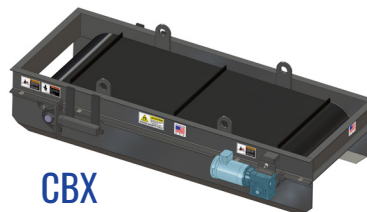

CBX

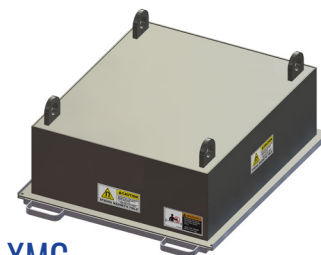

XMG



Electromagnetic Separators

Douglas® Helios™ electromagnetic separators are used in applications where a stronger magnetic field is required due to suspension height, belt speed or burden depth. These magnets are popular for protection of downstream equipment in conveyor systems, including crushers and bark hogs.

Electromagnetic separators are oil-filled and utilize state-of-the-art anodized aluminum coils, expansion tanks, and solid core construction for maximum performance and longevity. Douglas also offers robust power supplies. NEMA 4 enclosures are standard with 480 VDC power supplies. Custom cabinets and special voltage inputs are available on request. Anodized aluminum coils have a standard 10 year warranty.

Sizes Available

- 18" to 72" belt widths
- Up to 26" suspension heights
- Custom sizes and application specific designs

Self Cleaning Electromagnetic Separators (ESH)

- Automatically discharges tramp metal away from the conveyor
- Heavy grade structural steel frame complete with CEMA class lagged crown face head pulley, tail pulley and Slide Tube® belt take-ups
- Heavy duty rubber cover belt standard with hot vulcanized cleats
- Shipped complete, factory test run and ready for installation
- CLASS II shaft mount gear drive with TEFC motor (custom drives available)



ESH

Manual Cleaning Electromagnetic Separators (EMH)

- Manual cleaning of ferrous metal required
- Power off for easy cleaning
- Shipped complete and ready for installation



EMH



Metal Detectors

Douglas® Assurance™ metal detectors are available in dual probe configurations. The compact design allows installation in almost any application. The sensitivity can continuously be adjusted if only larger pieces of metal are to be detected. The control unit has self-adjusting electronics housed in a durable, metal cabinet. Power switches and output relays are gold plated providing reliable service. The unit can be integrated into an existing plant control system without any extra components.

Ideally suited for Quarries, Mining, Recycling, Slag Processing, Cement, Brick Plants, Forest Products and Recycling as well as other applications.

- Detects both ferrous and non-ferrous metals
- Magnetite from iron oxide and ore are ignored
- Can be operated in close proximity to frequency converters
- Can be operated near magnets (minimum distance of 6 feet)
- Probe(s) constructed of high temperature PVC plastic for durability
- Special secondary sensitivity in area of metal splice or repair clip
- Adjustable primary sensitivity during operation
- Accepts both 110 VAC and 220 VAC single phase power



Impact Beds & Bars

Douglas Impact Beds are engineered to protect the conveyor belt at key transfer point areas. They help to keep material on the belt where it belongs. Impact beds help to absorb shock loads and support the full width of the conveyor belt. They help to eliminate the cost of idler maintenance and failure. No more bent idler shafts and frames, or worn out rollers to replace.

Titan™ Adjustable Impact Bed Assembly (IBA)

- Adjustable wing height easily changes from flat, 20° or 35° as needed
- Support arms adjustable from flat to 20° and 35°
- Easy installation, fold one side flat and slide under the belt
- 48" and 60" long beds and bars available
- Center impact rolls available (IRB)

Titan™ Sectional Impact Bed Assembly (ISE)

- Reduce down-time with 3 easily removable sections while the conveyor belt is in place
- Fixed angles of 20°, 35° or 45° (specify at time of order)
- Removable sections allow simple bar replacement
- Sections allow for ease of installation in tight or out of the way applications
- 48" and 60" long beds and bars available
- Center impact rolls available (ISR)

Impact Bed Bars (IBB) & T-Bolts (ITB)

- Replacement Impact Bars mount using field proven T-Bolt locking system
- Profiled leading edge helps increase service life of bars
- Anodized aluminum insert helps to prevent corrosion and ensure simple bar replacement
- Easily retrofits to many other manufacturer's impact bed assemblies
- 48" and 60" long bars available

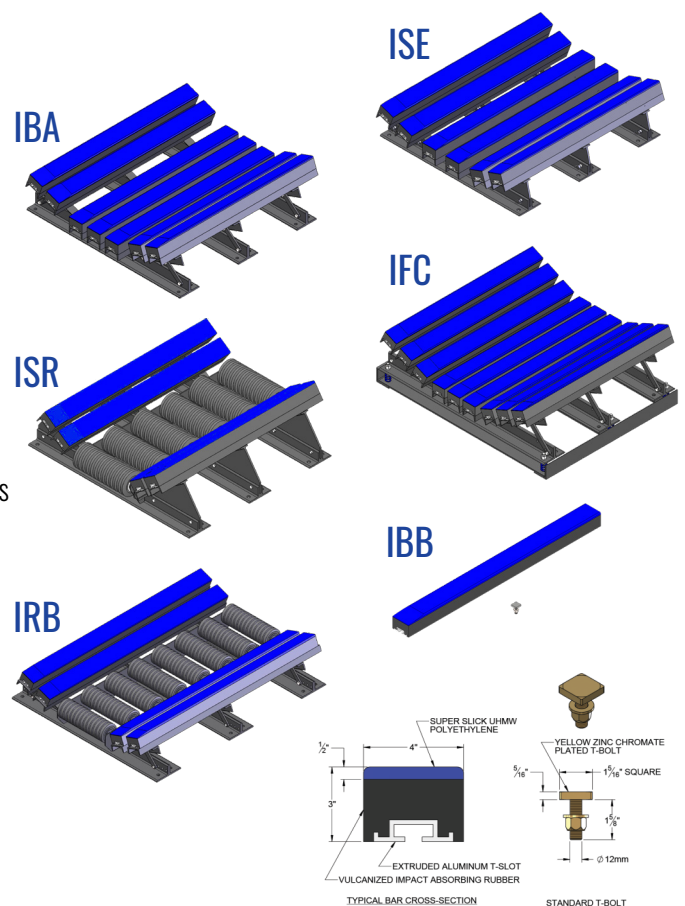

Take-Up Frames & Assemblies



DOUGLAS MANUFACTURING
STT-A3012
MADE WITH PRIDE IN PELL CITY, AL USA

The Slide Tube™ (STT) tough and dependable. The space saving design eliminates the need for additional take-up supports and allows for even load distribution.

The Top Angle (TAF) features a bolted top angle protects the threaded rod and allows for relatively simple bearing removal and replacement. Available with an optional channel or round bar bottom piece to accommodate SKF and Linkbelt or Dodge bearings respectively.

The Center Pull (CPT) is suitable to a wide variety of applications. The location of the threaded rod, in the center of the frame and bearing, helps to ensure even tensioning during operation. ACME™ all thread rod standard.

The Heavy Duty Top Mount (HDT) is designed for severe applications. The single piece heavy mounting plate is designed for a four bolt pattern style bearing but can be manufactured for two bolt bearings. The extra heavy welded steel construction helps ensure long-life and dependability in the roughest applications

The Light Duty Top Mount (LDT) is a two piece saddle design that is adjustable and can accommodate a wide range of 2 bolt pillow block bearings.

The Wide Slot Side Mount (WST) is designed to fit in very tight spaces. It mounts on the side of a conveyor frame or chute and uses wide slot ball bearings.

The Scissors Pivot® Gravity Take-Up (STU) is an engineered take-up system that incorporates a standard assembly consisting of 3 pulley assemblies, a lever arm and support chains (not shown). It automatically adjusts for belt stretch and is engineered for proper belt tension.

ACME™ all thread rod standard. ¹Bearings are provided separately.

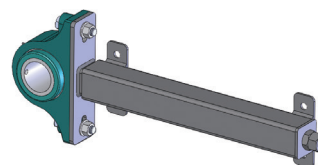

STT

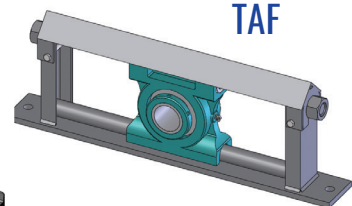

TAF

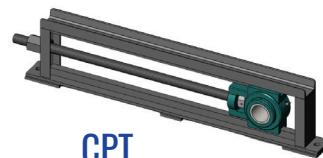

CPT

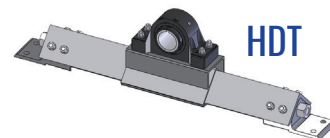

HDT

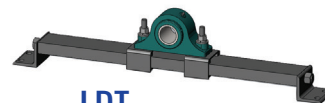

LDT

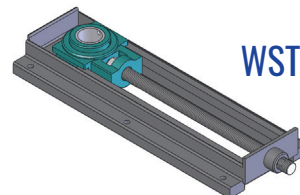

WST

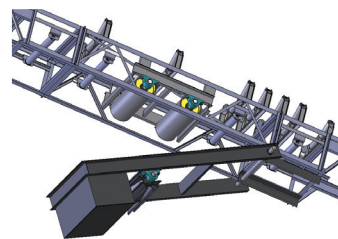

STU

Premium Return Roll Guard **GUARDIAN³**
U.S. Patent Number 6,318,545 B1

Guardian³ Premium Return Roll Guard

DESIGN FEATURES

- Patented 180° UHMW Cage provides complete pinch point protection and catches the roll if it breaks away from the brackets.
- UHMW UV stable cage has increased slot sizes and new self cleaning slots in the bottom to help resist material build-up inside the guard.
- UHMW will not corrode, resists impact damage and wear from abrasion.
- UHMW side shield totally encapsulates the roll and snaps into place easily and securely using the provided heavy gauge steel mounting brackets.

EASY INSTALLATION

Two options are provided for mounting: galvanized steel nuts, bolts and washers and optional pin and clevis for use on the back side of the roll to allow for easy maintenance and cleaning.

The end shield is snapped securely in place using the provided hanging brackets and integrated mounting system.

EASY MAINTENANCE

The Guardian³ requires little to no maintenance due to its unique, trouble free design. The wider self cleaning slots in the bottom of the guard help with self-cleaning ability and the deep reservoir design means less frequent cleaning if material build-up occurs. Clean out is a snap. Simply remove the fast action pins and allow the Guardian³ to open to the cleaning position. The side shield is designed with a single large maintenance and viewing port to allow for greasing of idlers and roller inspection without the need to remove the side shield.

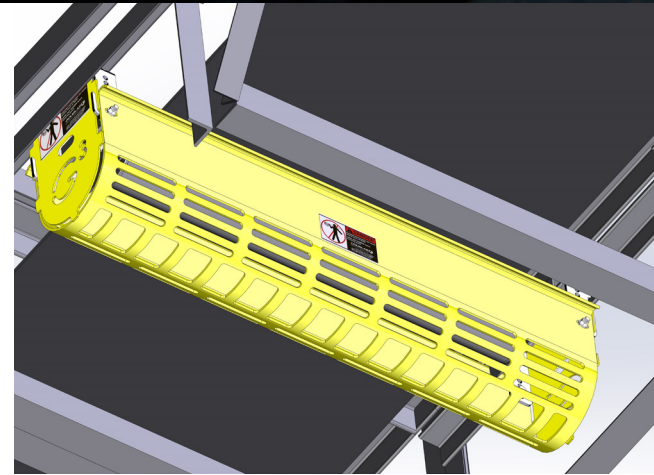

COMPLIES WITH MSHA TITLE 30 CFR

- 56.14110 Flying or Falling Material
- 56.14112 Guard Construction
- 56.14107 Moving Machine Parts
- 5.1722 Mechanical Equipment Guards
- 7.400 Mechanical Equipment Guards

2-3/4 X 2 SLOTS DESIGNED TO ENHANCE
SELF CLEANING

Meets OSHA requirements 1910.219 for
mechanical power - transmission apparatus
and 56.14107 for moving machine parts

U.S. Patent Number 6,318,545 B1

CEMA E VERSION AVAILABLE



CEMENT



FOREST PRODUCTS



AGGREGATE



SHIP LOADING



COAL AND POWER GENERATION



MINING



AGRICULTURE

For more than forty years Douglas has codified its legacy as a leader and innovator in the conveyor industry. Douglas is on a mission to maintain its status as a recognized leader and continue to help our customers make their conveyor operations safer and more profitable.

4 STOCKING LOCATIONS

24-48 HOUR DELIVERY



MADE IN THE USA



SINCE 1978



300 Industrial Park Drive, Pell City, AL 35125 (U.S.A)

Visit us at douglasmanufacturing.com

Contact us 205-884-1200 or sales@douglasmanufacturing.com

