



PRODUCTS AND SERVICES THAT LEAD TO SOLUTIONS
ALL IN ONE BROCHURE



AGGREGATE



CEMENT



COAL



ENERGY



METALS



MINERALS



PULP & PAPER



RECYCLING



SHIPPING
TERMINAL

Need Solutions...*to improve efficiency, safety and productivity?* **ask... ASGCO®**
www.asgco.com | [800.344.4000](tel:800.344.4000) | info@asgco.com





ABOUT US

PRODUCTS AND SERVICE THAT LEAD TO SOLUTIONS

At ASGCO®, our core motivation is to solve problems. We love a challenge, and thrive under pressure. We don't just provide the highest quality products and service; we deliver solutions.

Providing solutions for your conveyor issues is at our core. From engineers to designers, from technicians to product specialists. It's what drives everyone at ASGCO®, and the job is never done until our customer is satisfied.....**IT'S OUR GUARANTEE!**



MAXIMIZING EFFICIENCY



INCREASING PRODUCTIVITY



IMPROVING SAFETY

A HERITAGE OF INNOVATION

Since our founding in 1971, by Alfred S. Gibbs and his son Todd, ASGCO® has pioneered some of the most effective products in use for improving bulk material handling. We believe in taking care of the customer with great quality products and exceptional service. This has been a successful and standard policy at ASGCO® for many years and will continue in the future..

FOCUSED ON SOLUTIONS

At ASGCO® we continue to strive to make the handling of bulk materials cleaner, safer, and more productive. No matter what the basic assignment, we always seek out ways to increase production and to reduce operating costs. ASGCO® uses innovative products and engineered solutions to solve problems happening now and to prevent problems from happening in the future.

JUST ASK ASGCO!

What may seem like a problem to our customers is just a chance for us to put every resource we have in motion. And no matter what the basic assignment, we always seek out ways to increase production and to reduce operating costs. Our team is always ready. All you need to do is ask ASGCO®!

OUR PROMISE...

Applies to every client, every time. Always think and work in terms of solutions that are best for the customer in the long term. Provide prompt, reliable service to every client, every time. Develop and sell products that satisfy the practical working needs of our customers.

“Today, ASGCO® “Complete Conveyor Solutions” is recognized as the world-wide leader in bulk conveyor material handling systems.”

PROVIDING THE WORLD'S MATERIAL HANDLING INDUSTRY WITH
EFFICIENT, SAFE AND PRODUCTIVE
COMPLETE CONVEYOR SOLUTIONS

PRIMARY BELT CLEANERS

Skalper® Belt Cleaner 2
 Super-Skalper® HD Belt Cleaners 2
 Skalper® MDX Belt Cleaners 2
 Pit Skalper® 3
 Mini-Skalper® 3
 Excalibur™ Belt Cleaners 3

PRIMARY & SECONDARY BLADE & TENSIONER CHARTS ... 4-5

SECONDARY BELT CLEANERS

BC-2™ 6
 Razor-Back® Belt Cleaner 6
 Razor-Back® Retractable Belt Cleaner 6
 Razor-Back MDX™ Belt Cleaner 7
 TORO™ Belt Cleaner 7
 Wash Box Belt Cleaning System 7
 Chevron™ Belt Cleaner 8
 Rotary Rubber Brush Cleaner 8
 Hinged V-Plow™ 8
 V-Plow Xd™ 8
 Diagonal Plow 8
 Vibrating Dribble Chute 8

CONVEYOR IDLERS

Steep Angle Accessories 9
 Tru-Trainer® Flat Return 10
 Tru-Trainer® Dual Return 10
 Tru-Trainer® Dual V-Return 10
 Tru-Trainer® Dual Return Urethane 10
 Tru-Trainer® Dual V-Return Urethane 10
 Tru-Trainer® Tapered Troughing Idler 11
 Dura-Sleeve™ Idlers 11
 Slide-Lers™ 11

LOAD ZONE & TRANSFER POINT

Slide-N-Roll™ Beds 12
 3 Roll Slide-N-Roll™ Beds 12
 Roller Cassette™ Beds 12
 Impact Cradle Bed™ 13
 Pro-Zone™ 13

SKIRTING & DUST CONTROL

Double Handle Clamp-Mount® System 14
 Clamp-Mount™ MDX 14
 Tri-Seal™ 14
 Multi-Seal™ 14
 SX3™ 14
 Dura-Seal™ (ORG) 14
 B&R Dura-Seal™ 14
 Dura-Tuff™ 14
 External Wear Liner 15
 E-Z Mount® 15
 Dust Control Curtain 15
 Chute Tail Box 15

TRANSFER POINT DESIGN & FABRICATION

ASGCO® Flo-Control™ - Conveyor Transfer Points 16
 3-DEM™ Transfer Point Design 16

WEAR LINERS

Armorite® 700 17
 Skirtboard Wear Liners (Urethane, Steel Rubber, Ceramic) 17
 X-Wear™ Mine Duty Wear Liner 17
 X-Wear™ Urethane Magnetic Liner & Patch 18
 X-Wear™ (Ceramic) 18
 Nitronic SX™ 18

PULLEY LAGGING

Arrowhead® Ceramic Pulley Lagging 19
 Semi-Ceramic™ Pulley Lagging 19
 Arrowhead® Drive & Plain Rubber Pulley Lagging 19

SAFETY EQUIPMENT & GUARDING

Safe-Guard® Return Idler Guard 20
 Safe-Guard® HD Return Idler Guard 20
 Safe-Guard® V-Return Idler Guard 20
 Safe-Guard® Return Idler Cage 20
 Safe-Guard® Flat Guard 20
 Safe-Guard® Chute Inspection Doors 21
 Safe-Grip™ Belt Clamps 21
 Safe-Guard® Return Roll Changer 21

VULCANIZING PRESSES

Vul-Con™ Sectional Press 22
 Vul-Con™ EZ Series Press 22
 Control Box 22

CONVEYOR TRAINING & ACCESSORIES

ASGCO® Conveyor Training ACT™ 23
 - Conveyor Training 101 Program 23
 - Conveyor Product Installation Training 23

SERVICE & SUPPORT

Laser Alignment 24
 Point Cloud 24
 ASGCO® Services 24

PRIMARY BELT CLEANERS - MINE DUTY

Skalper® Belt Cleaner

Our newly enhanced Skalper® series of conveyor belt pre-cleaners have been installed and have solved carry-back problems all over the world. The simple and highly effective Skalper® belt cleaner removes carry-back from the conveyor system.

- **Skalper®** - (patented) one piece blade maintains an effective cleaning edge throughout the life of the blade
- **E-Z Torque®** - (patented) torsion style tensioning system provides a constant consistent tension throughout the life of the blade
- **Available** - with Force-1™ Tensioner



Maximum Belt Speed – 1000 fpm (5.0 m/sec)
Pulley Diameter – 12" – 36" (300 – 900mm)
Applications – Coal Fired Power Plants, Hard Rock Mining, Steel Mills, Iron Ore, Aggregate and Mineral (Phosphate, Potash, Salt) Mining
CEMA Class 4



Super-Skalper® HD Belt Cleaner

The Super-Skalper® HD conveyor belt pre-cleaner can tackle the toughest carry-back applications. The Super-Skalper® blade provides carry-back removal for high-speed belts, large head pulleys and large sizes and volumes of material, typically found in above and below ground mining.

- **One Piece Single Mounting Tube** - for new robust, enhanced HD E-Z Torque® tensioner.
- **E-Z Torque® HD Tensioner** - (lifetime warranty) patented made of all 304 stainless steel mounting plates, collars and springs allows the blades to self adjust throughout the entire life of the blade.
- **Available** - with Spring Shoc™ or Air-Shoc™ and 3 piece designed mounting tube



Maximum Belt Speed – 1200 fpm (6.0 m/sec)
Pulley Diameter – 20" + (400mm +)
Applications – Underground Mining, Hard Rock Mining, Metals (copper/gold) Mining, Steel Mills, Iron Ore, Bulk Shipping Terminals, Coal Fired Power Plants, Coal Preparation Plants
CEMA Class 5



Skalper MDX® Belt Cleaner

The Skalper MDX® conveyor belt pre-cleaner is designed for high speed and high tonnage conveyor systems in above ground and underground mining. The heavy-duty urethane blade mounts against the head pulley for efficient conveyor belt cleaning, and our unique torque cam action lever adjusts itself to remove high volumes of carry-back while minimizing blade wear and wear from mechanical fasteners. Guaranteed mine tough!

- **Impact absorbing Torque-Cam™** - action mounting system adjusts itself when large impact forces from mechanical fasteners or large lumps of carry-back hit the cleaner
- **Engineered** - for the most abusive conditions and applications
- **Installed** - as individual blade or as a cartridge
- **Available** - with Spring Shoc™ or Air-Shoc™



Maximum Belt Speed – 1200 fpm (6.0 m/sec)
Pulley Diameter – 24" + (600mm +)
Applications – Underground Mining, Hard Rock Mining, Oil Sands Mining, Metals (copper/gold) Mining, Steel Mills, Iron Ore, Bulk Shipping Terminals
CEMA Class 5

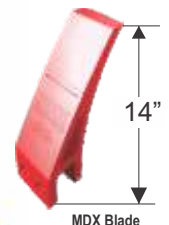

PRIMARY BELT CLEANERS

Pit-Skalper® Belt Cleaner

ASGCO® Pit-Skalper® conveyor belt pre-cleaner is highly effective in challenging service conditions to remove carry-back from the conveyor system.

- **Pit-Skalper® Blade design** - (patented) maintains an effective cleaning edge throughout the life of the blade
- **Zinc Plated** - blade mounting tube and bracket assemblies offer the highest standard in corrosion resistance in a variety of applications.
- **E-Z Torque® Tensioner** - is a patented tensioner featuring stainless steel spring, allows the blades to self adjust throughout the entire life of the blade and is the most robust and accurate belt cleaner tensioner in the industry.



Maximum Belt Speed – 600 fpm (3.0 m/sec)
 Pulley Diameter – 10" – 20" (250 – 500mm)
 Applications – Aggregate, Ready Mix, Asphalt, Recycling, Sand and Gravel
CEMA Class 3

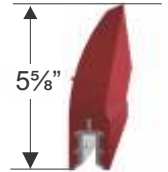

Mini-Skalper® Belt Cleaner

The unique Mini-Skalper® conveyor belt pre-cleaner is designed for small diameter pulleys where space and size is a factor. This belt cleaner is ideal in situations where the head pulley is less than 16" (400mm) in diameter or tight locations.

- **Mini-Skalper®** - (patented) compact one piece blade maintains an effective cleaning edge throughout the life of the blade
- **Force-1™** - Tensioning system provides constant tension
- **Blade-Wear Indicator** - allows you to monitor blade wear easily without having to shut the system down for inspection.

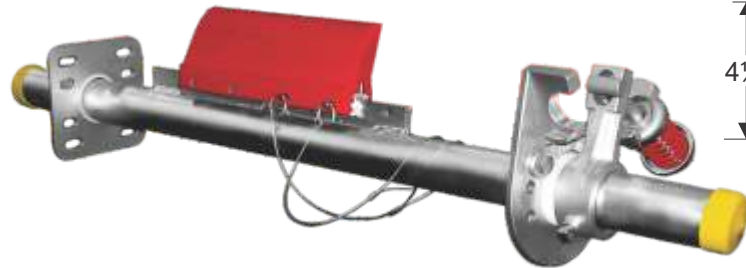

Maximum Belt Speed – 500 fpm (2.5 m/sec)
 Pulley Diameter – 6" – 22" (150 – 550mm)
 Applications – Aggregate, Sand & Gravel, Redi-Mix and Asphalt, Cement, Wood Processing Recycling
CEMA Class 2

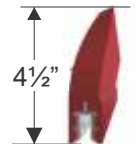

Excalibur® Food Grade Conveyor Belt Cleaner

Excalibur® is particularly suited for light duty thermoplastic belts with widths from several inches to 10'. Excalibur® is designed and configured to meet the most stringent sanitary requirements of the food manufacturing industry and uses USFDA and USDA approved materials.

- Sanitary and safe lightweight
- Works great on flexible modular plastic table top conveyor belting
- Features a unique blade, holder and tensioning mechanism
- Snap-on/off conveyor belt scraper blade
- FDA/USDA compliant materials



Pulley Diameter – 1" – 8+" (25– 200mm)
 Applications – Food, Baking, Meat and Poultry and Pet Food Processing Industry (FDA Industry)
CEMA Class 2

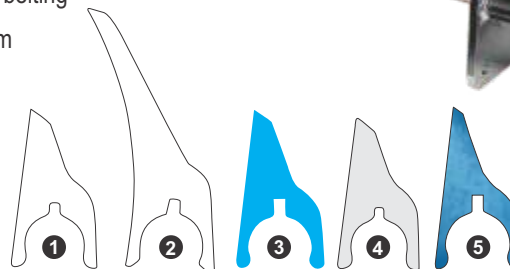

Replacement Blades Snap-On
 01. UHMW Natural
 02. UHMW Long Neck
 03. UHMW Blue
 04. Nylon Blade
 05. Metal Detectable

PRIMARY BELT CLEANERS

Primary belt cleaners are installed at the 9 o'clock position on the face of the head pulley, referred to as the primary position. It should be mounted below the trajectory flow of the material being discharged from the belt. These are the most common type of belt cleaner.

Pre-Cleaner	Mini-Skalper®	Skalper®	E-Z Skalper®	Super-Skalper®	Skalper MDX™
Belt Width	18"-48" 450-1200 mm	18"-96" 450-2400 mm	18"-96" 450-2400 mm	36"-96" 900-2400 mm	36"-96" 900-2400 mm
Belt Speed	< 500 fpm 2.5m/sec.	< 1000 fpm 5.0m/sec.	< 1000 fpm 5.0m/sec.	< 1200 fpm 6.0m/sec.	< 1200 fpm 6m/sec.
Head Pulley Diameter	6-22" 150-550 mm	16"-36" 400-900 mm	16"-36" 400-900 mm	20" + 400 mm +	24" + 600 mm +
Primary Tensioners					
Force-1™	YES	YES	YES	NO	NO
E-Z Torque®	YES	YES	YES	YES	NO
Air-Shoc™ (Primary)	NA	NA	NA	YES	YES
Spring-Shoc™ (Primary)	NA	NA	NA	NA	YES
Belt Conditions					
OK on reversible belt?	YES	YES	NO	YES	YES
Blade Materials					
Skalper® IV	YES	YES	YES	YES	YES
Skalper® III	YES	YES	N/A	NO	NO
Skalper® II	YES	YES	YES	YES	YES
Skalper® HT	YES	YES	YES	YES	YES
Skalper® UHT	YES	YES	YES	YES	YES
Skalper® XC (Ceramic)	N/A	N/A	N/A	YES	YES
Skalper® AR	YES	YES	YES	YES	YES

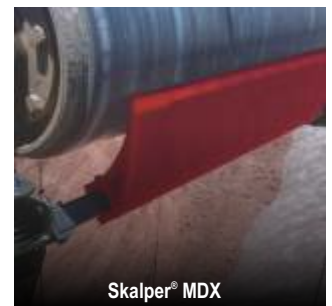
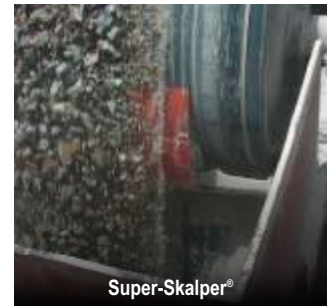
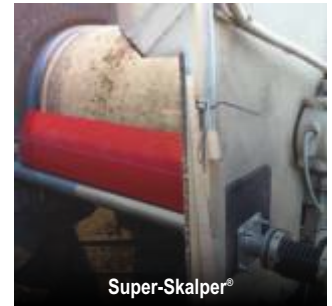
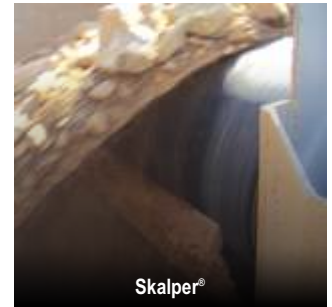

Skalper® Blades

Skalper® Blade Materials							
Blade Type	Skalper®IV	Skalper®III	Skalper®II	Skalper®HT	Skalper®UHT	Skalper®XC	Skalper®AR
Durometer	82	82	95	82	95	82	95
Description	Abrasion Resistant	General Use	Xtra Abrasion Resistant	High Temp	Ultra High Temp	Ceramic	Acid Resistant
Belt Speed	< 1000 fpm < 5m/sec	< 700 fpm < 3.5m/sec	< 1200 fpm < 6m/sec	< 1000 fpm < 6m/sec	< 1200 fpm < 6m/sec	< 1400 fpm < 7m/sec	< 1400 fpm
Temperature Range	-20-180°F -28 to 82°C	-20-180°F -28 to 82°C	-20-180°F -28 to 82°C	-20-225°F -28 to 107°C	-20-300°F -28 to 148°C	-40-225°F -40 to 107°C	-40-225°F -40 to 107°C
Use w/Mech. Fasteners	Yes	Yes	No	Yes	No	No	No

Primary Tensioners

E-Z Torque®	Spring Shoc™	Air-Shoc™	Force-1™
<ul style="list-style-type: none"> All 304 stainless steel construction Lifetime Warranty Stainless steel torsion spring will not take a set 	<ul style="list-style-type: none"> Zinc plated mild steel construction Lifetime Warranty Rubber and UHMW impact bushing 	<ul style="list-style-type: none"> Enclosed air system with auto-motive quality shocks maintain constant blade to belt contact for continuous cleaning pressure. 	<ul style="list-style-type: none"> All 304 stainless steel construction Lifetime Warranty Compact size

Primary Mounting Brackets

E-Z Torque® Extension Bracket	Boss Block	Mounting Plate
<ul style="list-style-type: none"> E-Z Torque tension side extension bracket provides additional clearance for ease of tensioning Made from zinc plated mild steel 	<ul style="list-style-type: none"> W1" X L8" with (4) 5/8-11 tapped holes Weld on both sides of pulley and bolt on steel plate 	<ul style="list-style-type: none"> H15" X L30" with (4) 5/8-11 holes For use with Boss Block to mount pre-cleaners on open head pulleys

SECONDARY BELT CLEANERS

Secondary belt cleaners are installed after the point where the belt leaves the head (discharge) pulley and or anywhere on the return side of the belt where it can be cleaned and maintained effectively.

Secondary Cleaners	TORO™	Razor-Back®	Razor-Back MDX®	Chevron™	BC-2™
Belt Width	18"-96" 450-1200 mm	18"-96" 450-2400 mm	18"-96" 450-2400 mm	18"-96" 450-2400 mm	18"-72" 450-1800
Belt Speed	<1000 fpm 5m/sec.	< 1000 fpm 5m/sec.	< 1200 fpm 6m/sec.	< 500 fpm 2.5m/sec.	<800 fpm 4 m/sec.
Secondary Tensioners					
Bolt-Up™	YES	YES	NA	NA	YES
Spring-Shoc™	YES	YES	NA	NA	NA
Bolt-Up™ MDX	NO	NO	YES	NA	NA
Air-Shoc™ MDX	NO	NO	YES	NA	NA
Spring-Shoc™ MDX	NA	NA	YES	NA	NA
Belt Conditions					
OK on reversible belt?	YES	NO	NO	YES	NO
Blade Materials					
TORO™ U-Tips	YES	N/A	N/A	N/A	N/A
TORO™ F-Tips	YES	N/A	N/A	N/A	N/A
TORO™ C-Tips	YES	N/A	N/A	N/A	N/A
F-Tips	N/A	YES	N/A	N/A	N/A
C-Tips	N/A	YES	N/A	N/A	YES
V-Tips	N/A	YES	N/A	N/A	YES
U-Tips	N/A	YES	N/A	N/A	N/A
XC-Tips	N/A	YES	YES	N/A	N/A
MDX F-Tips	N/A	YES	YES	N/A	N/A
MDX C-Tips	N/A	YES	YES	N/A	N/A
MDX V-Tips	N/A	YES	YES	N/A	N/A



Secondary Blades

Blade Materials											
Blade Type	TORO™ U-Tips	TORO™ F-Tips	TORO™ C-Tips	F-Tips	C-Tips	V-Tips	U-Tip	XC-Tip	MDX F-Tips	MDX C-Tips	MDX V-Tips
Belt Speed	< 1000 fpm < 5 m/sec	<1000 fpm < 5 m/sec	< 1000 fpm < 5 m/sec	< 1000 fpm < 5 m/sec	< 1000 fpm < 5 m/sec	< 1000 fpm < 5 m/sec	< 1000 fpm < 5 m/sec	< 1400 fpm < 7 m/sec	< 1200 fpm < 6 m/sec	< 1200 fpm < 6 m/sec	< 1200 fpm < 6 m/sec
Temperature Range	-20-180°F -28 to 82°C	-20-180°F -28 to 82°C	-20-180°F -28 to 82°C	-20-400°F -28 to 204°C	-20-400°F -28 to 204°C	-20-400°F -28 to 204°C	-20-180°F -28 to 82°C	-20-400°F -28 to 204°C	-20-400°F -28 to 204°C	-20-400°F -28 to 204°C	-20-400°F -28 to 204°C
Use w/Mech. Fasteners	Yes	Yes	Yes	Yes	Yes	No	Yes	No	Yes	Yes	No

Secondary Belt Cleaner Tensioners

Bolt-up™ / Bolt-up MDX™	Spring-Shoc™ / MDX	Duo-Spring™	Air-Shoc MDX™	Secondary Mounting Bracket
<p>Push-Up Pull-Up</p> <ul style="list-style-type: none"> • Powder coated steel bracket • 304 stainless steel construction of adj. blocks • Lifetime Warranty • Visual tension check • Push-up or Pull-up tensioning options 	<ul style="list-style-type: none"> • Zinc plated steel HD construction • Lifetime Warranty • UHMW slide bushings • Push-up or Pull-up tensioning options 	<ul style="list-style-type: none"> • All 304 stainless steel construction • Lifetime Warranty • Push-up or Pull-up tensioning options 	<ul style="list-style-type: none"> • Zinc plated steel HD construction • Lifetime Warranty • UHMW slide bushings 	<ul style="list-style-type: none"> • Powder coated mild steel • Available in Stainless Steel upon request

SECONDARY BELT CLEANERS

BC-2 Belt Cleaner

- **High Belt Cleaning Efficiency.** The overlapping tungsten carbide blades and the constant tension provided by the patent pending stainless steel spring self-tensioning arm assembly.
- **Made for Mining and Tough Applications.** Our heavy duty 2-7/8" corrosion resistant zinc coated (Made in the USA) steel mounting tube and stainless steel spring self-tensioning arms and blades provide constant cleaning without the rust of chipped powder coating.
- **Flexible Configuration.** Engineered to be installed in different configurations and also gives you the option to locate the blades directly on the bottom of the head pulley.
- **Safe and Easy to Service.** Each tungsten carbide blade can be replaced from the self-tensioning arms without the need to replace the arm every blade change.

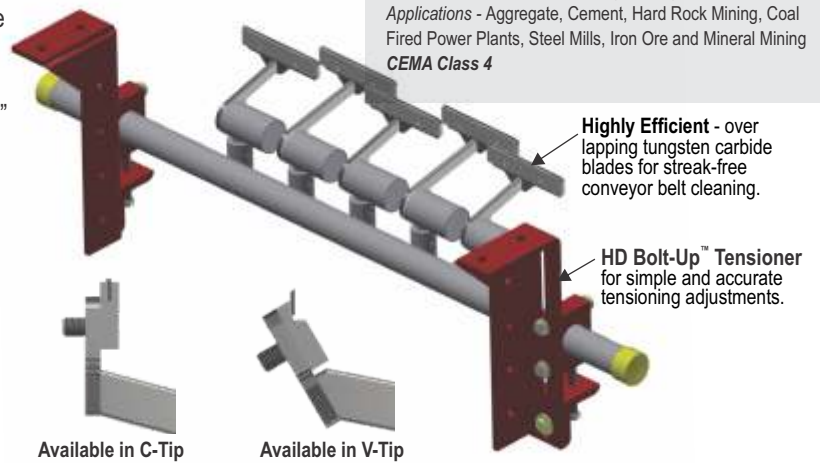

Razor-Back® Belt Cleaner

- Impact absorbing, self-tensioning cushions allow each blade to flex individually and allow a more constant effective tension against the conveyor belt.
- Available with replaceable V-Tips for vulcanized conveyor belts or C-Tips or F-Tips for conveyor belts with mechanical fasteners.
- Slide-out service cartridge allows for easy service and inspection
- Available with optional water spray.

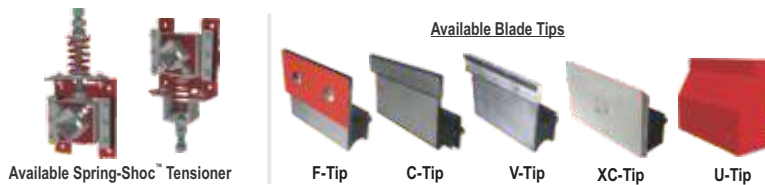

Maximum Belt Speed - 1000 fpm (5.0 m/sec)
Applications - Coal Fired Power Plants, Hard Rock Mining, Steel Mills, Iron Ore, Aggregate and Mineral (Phosphate, Potash, Salt) Mining
CEMA Class 3 - Bolt-Up™ / CEMA Class 4 Spring-Shoc™

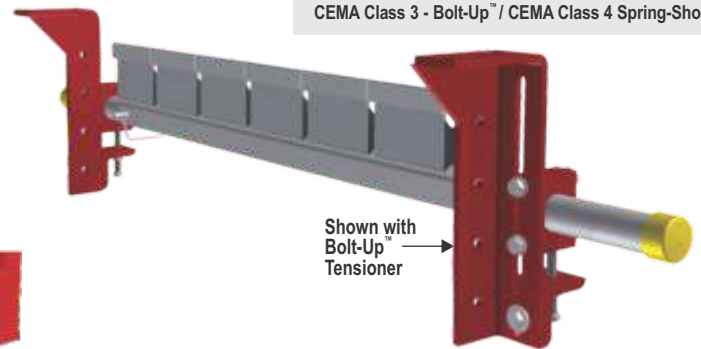

Razor-Back® Retractable System

- **Longwearing Abrasion Resistant** - tungsten carbide blades provides and maintains a great cleaning edge against the conveyor belt.
- **Quick-Change** - slide-out mounting system allows for simple removal of the cartridge from one side of the conveyor system, without having to break the plane of the conveyor structure, or having to remove mounting brackets or the main mounting tube.
- **Compact Design** - allows for an installation that requires less than 9" of clearance to be installed and maintained.



Maximum Belt Speed - 1000fpm (5.0 m/sec)
Pulley Diameter - 16" - 36" (400 - 900mm)
Applications - Coal Fired Power Plants, Hard Rock Mining, Steel Mills, Iron Ore, Aggregate and Mineral (Phosphate, Potash, Salt) Mining
CEMA Class 4

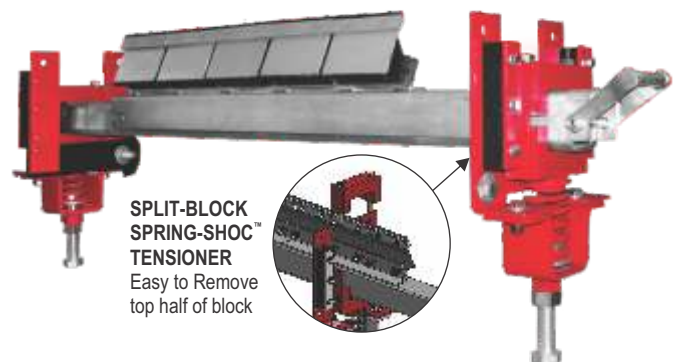

SECONDARY BELT CLEANERS

Razor-Back® MDX Belt Cleaner

- **Force-Flex™** – (patent pending) impact absorbing rubber and spring-loaded tensioning cushions maintain a constant effective force between the belt cleaner and the conveyor belt.
- **Available** – with replaceable MDX™ V-Tips for vulcanized conveyor belts or MDX™ C-Tips for conveyor belts with mechanical fasteners.
- **Slide-out** – service cartridge allows for easy service and inspection.
- **Available** – with Bolt-up™, Spring-Shoc™ or Air-Shoc™ Tensioning Systems.

Available Tensioners



Air-Shoc™ Bolt-Up™ MDX

Available Blade Tips

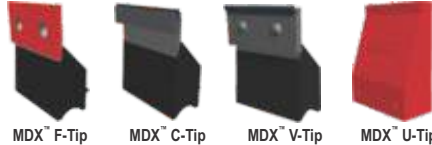

MDX™ F-Tip MDX™ C-Tip MDX™ V-Tip MDX™ U-Tip

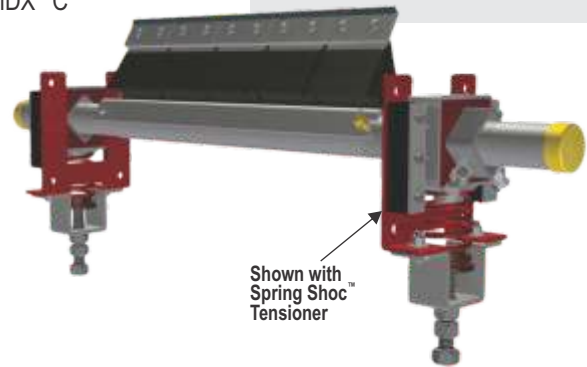

Shown with Spring Shoc™ Tensioner

Maximum Belt Speed – 1200 fpm (6.0 m/sec)
Applications – Underground Mining, Hard Rock Mining, Metals (copper/gold) Mining, Steel Mills, Iron Ore, Bulk Shipping Terminals, Coal Fired Power Plants
CEMA Class 5

TORO™ Belt Cleaner

Toro™ secondary belt cleaner is an effective flexible secondary belt cleaner that is also suitable for reversing conveyor belts. The cartridge blade system allows for easy blade change-outs and available with 3 different blade styles and 2 different tensioners depending on the application.

- Effective flexible belt cleaner that can accommodate reversing conveyor belt systems.
- Designed for Reversing Conveyors – such as shuttles or conveyors that roll back, trippers, due to its unique two-way rubber cushions.
- Available with replaceable V-Tips for vulcanized conveyor belts or C-Tips or F-Tips for conveyor belts with mechanical fasteners.
- Slide-out service cartridge allows for easy service and inspection.
- Available with Bolt-Up™, Duo-Spring™ or Air-Shoc™ Tensioning Systems.

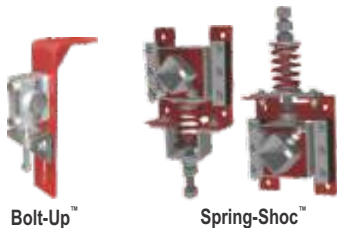

Bolt-Up™ Spring-Shoc™

Available Blade Tips



TORO™ F-TIP TORO™ C-TIP TORO™

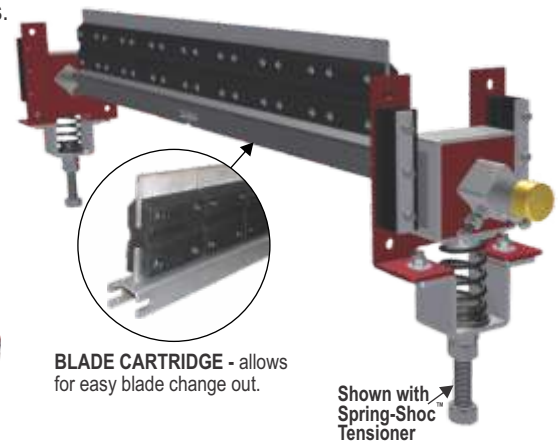

BLADE CARTRIDGE - allows for easy blade change out.

Shown with Spring-Shoc™ Tensioner

Maximum Belt Speed – 1000 fpm (5.0 m/sec)
Applications – Aggregate, Cement, Coal Fired Power Plants, Mineral (Phosphate, Potash, Salt) Mining, Wood Processing Recycling
CEMA Class 3 - Bolt-Up™ / CEMA Class 4 Spring-Shoc™

Wash Box™ Belt Cleaning System

The ASGCO® is installed as a secondary belt cleaner and is designed to work on Wash Box™ the return side of the conveyor belt. Each steel enclosed box is equipped with a combination of pressure rollers, spray bars and Razor-Back belt cleaners. It can also be customized to meet your exact needs. The nozzles apply a spray of water which softens the carry-back and lubricates to maintain effective cleaning pressure. The Wash Box provides the highest degree in belt cleaning technology. The highest degree in belt cleaning technology.

- Complete belt cleaning system that incorporates a series of spray bars, belt cleaners and pressure/deflection roll to maximize the effectiveness and virtually eliminate all carry-back.
- Fully enclosed system that contains the wash waste fluid and carry-back
- Large removable service doors allow the system to be easily inspected and service.
- Can be customized to meet exact application needs



Maximum Belt Speed – 1000 fpm (5.0 m/sec)
Applications – Coal Fired Power Plants, Bulk Shipping Terminals, Coal Preparation Plants, Underground Mining, Hard Rock Mining, Steel Mills, Iron Ore, Mineral (Phosphate, Potash, Salt) Mining
CEMA Class 3 - 4 - 5

SECONDARY BELT CLEANERS

Chevron™ Belt Cleaner System

The **Chevron™** secondary belt cleaner is designed to work only when the conveyor belt is running its' unique rotary fingers are forced against the base of the Chevron to dislodge material from the belt.

- Bolt-Up™ Style Mounting allows for easy adjustment up and down allowing cleaner pitch to be set with the turn of a wrench.
- Patented concave shaped rubber discs perform a sweeping action to clean chevron, raised top or grooved conveyor belts
- Easily serviced and no motors, air nozzles or other problematic equipment to maintain

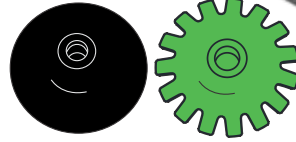

Chevron™ Discs are available in both, Rubber and Urethane, Notched or Solid.

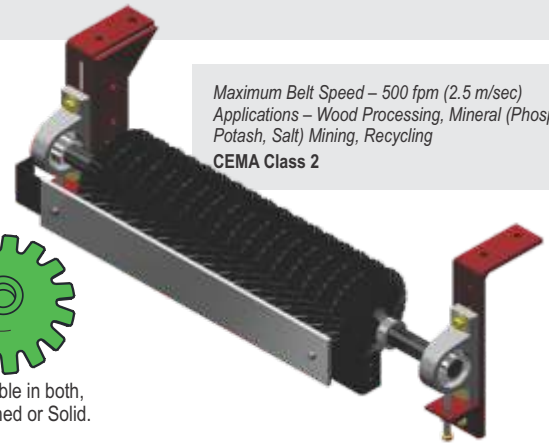

Maximum Belt Speed – 500 fpm (2.5 m/sec)
Applications – Wood Processing, Mineral (Phosphate, Potash, Salt) Mining, Recycling
CEMA Class 2

Rotary Rubber Brush Cleaner

The **Rotary Brush Cleaner™** secondary belt cleaner uses the speed and force of the belt rolling over hundreds of SBR finger tips, to provide effective cleaning on material that clings to cleated belts.

- **Excellent Elastic SBR Rubber Fingertips** – efficiently remove any materials that adhere to the belt surface, reducing serious material accumulation and residue build up on the return rollers.
- **Fast and Easy** – installation, adjustment, maintenance and blade change-out.
- **Sweeping Action** – unique rotary fingers remove the carry-back and are designed to work only when the conveyor belt is running.



Maximum Belt Speed – 700 fpm (3.5 m/sec)
Applications – Fines, Wood Dust, Cement Dust, Salt, Sugar, Fertilizer, Wet Sand and Carbon Black.
CEMA Class 3

Available with a Motor
Can be installed with a motor without excessive power consumption

SBR Rubber
Provides abrasion resistant for longer service life.

V-Plow XD™, Hinged V-Plow™ & Diagonal Plow Belt Cleaners

All "V" and Diagonal Plows are designed to remove material and clean the inside of the conveyor belt which protects and reduces the risk of puncture damage.

- V-Plow XD™ is a patent pending design for tough mine duty applications that can be flipped to maximize results.
- Hinged V-Plow™ is a patented "Hinged" design for low, tight clearance applications.
- Diagonal Plow discharges material from one side of the belt.
- Available with rubber or urethane plow material.

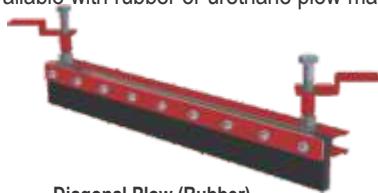

Diagonal Plow (Rubber)
Also Available in Urethane



Hinged V-Plow™ (Rubber)
Also Available in Urethane



V-Plow XD™ (Urethane)

V-Plow XD™ (Rubber)

Maximum Belt Speed – 1000 fpm (5.0 m/sec)
Applications – Coal Fired Power Plants, Hard Rock Mining, Underground Mining, Coal Preparation Plants, Steel Mills, Iron Ore, Aggregate, Metals (copper/gold) Mining, Mineral (Phosphate, Potash, Salt) Mining, Bulk Shipping Terminals
CEMA Class 3

Vibrating Dribble Chute

The ASGCO® Vibrating Dribble Chute combines a vibrator with a unique isolation mount and a low-friction UHMW chute liner to prevent buildup in dribble chutes.

- Vibrating liner keeps material moving and keep material accumulations from clogging chute and burying cleaners.
- Low friction UHMW lining promotes material flow without accumulation. Each liner is 1/2" thick by belt width and 36" in length. Custom size liners can be made at customers' request.
- "Isolation" bracket protects chute rubber-lined bracket transfers vibration to liner without metal fatigue.

Applications – Coal fired power plants, underground mining, coal preparation plants, aggregate metals (copper/gold) mining, mineral (phosphate, potash, salt) mining.



Mounting Bracket

Vibrator

Steep Angle Accessories

- **MDX Stub Idler** – custom designed, provides increased sidewall conveyor belt life and is designed for heavy load support. Available in a “drop” or “rise” design to fit all conveyor frame/belt combinations.
- **Canti-Wheel** – combine the bearings, shafts and wheels in one assembly. This design is a cost effective solution to deflecting the belt at the bend points and offers an OSHA friendly arrangement which eliminates the cross shaft, and is easier to guard.
- **Belt Beater** – work on the return or “clean” side of flexible sidewall or conventional troughed belts. It consists of a set of heavy wall rollers, rotating about a main shaft at approximately 600 RPM.
- **Dampening Roll Assembly** – reduces the pulsations in the belt, mounted just behind the beat beater that consists of 2 pairs of dual stub idlers that are matched to the belt recess, and a flat idler that “sandwich” the belt.
- **Tru-Trainer™** – designed for high speed, aggressive belts operates in all conditions, wet and dry. The Tru-Trainer™ idler has an internal central pivot that is perpendicular to the plane of the belt. The ends of the roller are tapered slightly so that the edges of the belt create a slight drag on the roller.



ASGCO® Stub Idler installed at a coal prep plant.

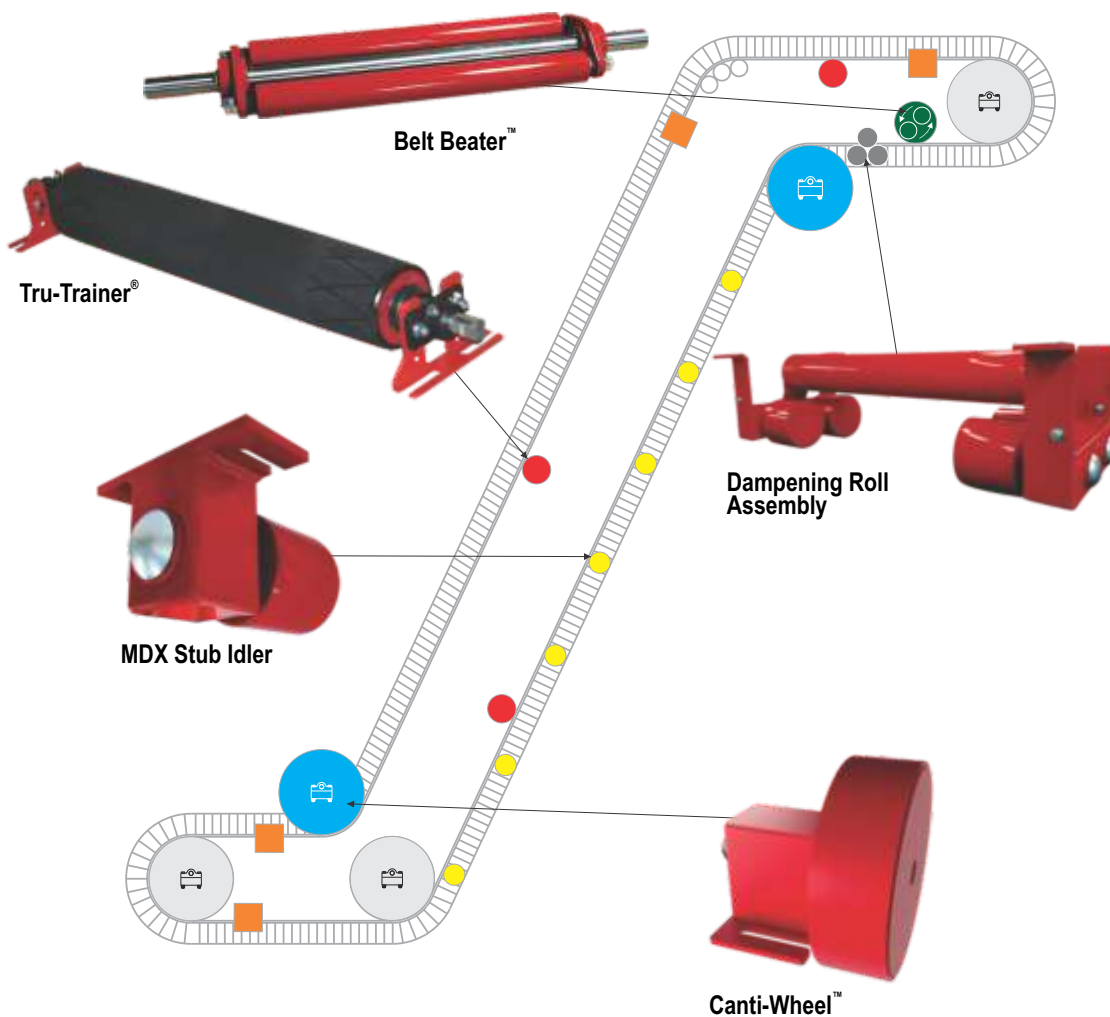

TRACKING & SPECIALTY IDLERS

Tru-Trainer® Flat Return Idlers

The Tru-Trainer® series of training idlers are a patented design that offers the most reliable and re-active training idlers available today. Its stainless steel internal pivot that is perpendicular to the plane of the belt and its rubber covered shell and tapered ends helps actuate the trainer immediately as the belt moves off center. It is always reacting to keep the belt centered. The Tru-Trainer® reacts as the belt moves off center it will contact the tapered section of the roller on that side of the belt. The effect of this will be to force the roller to rotate on its central pivot causing the belt to come back to its original position (centered).

- **Continuous Alignment** – by always tracking the belt to the center of the conveyor, it reduces edge damage, spillage and improves overall conveyor performance.
- **Heavy-Duty Design** – of our trainer uses 3 7/16" bearings, 1 3/4" shaft, and an abrasive resistant hot-vulcanized rubber cover. Urethane covers are also available.
- **Patented Design** – does not rely on the edge of the belt to activate the tracking mechanism and by utilizing an internal versus external pivot it does NOT build up with carry-back.
- **Reactionary** – in both wet and dry conditions as seen in below ground and above ground mining all over the world.
- **Polyurethane lagged rollers are also available.**
- **Excellent for Reversing Belt Applications.**
- **Can be used on the Clean Side of the Belt.**
- **Available in a Food Grade Idler**



Tru-Trainer®
Cut-a-way view



Tru-Trainer®
Flat Return Idler

Tru-Trainer® Dual Return Idlers

The Tru-Trainer® Dual Return was developed to accommodate the excessive forces encountered with wide belts and heavy loads. An external central pivot mechanism was designed, obviating the need for a single, large drum, and enabling a concentric and balanced rotation to be achieved.

- **Two Separate Tapered Rolls** – are mounted into the pivot mechanism and can be individually replaced as wear occurs.
- **Accommodates Excessive Force** – encountered with wide belts and heavy loads.
- **Individual Rollers for Easy Replacement** – separate tapered rolls are mounted onto the pivot mechanism, which can be individually replaced as wear occurs.
- **Available in low profile design for restricted applications.**
- **Polyurethane lagged rollers are also available.**



Also Available Tru-Trainer®
Dual V-Return Idler

Tru-Trainer® Dual Return Urethane Idlers (Mine Duty)

The Tru-Trainer® Urethane Dual Return was developed to accommodate the excessive forces encountered with wide belts and heavy loads. An external central pivot mechanism was designed, obviating the need for a single, large drum, and enabling a concentric and balanced rotation to be achieved.

- **Designed for High Speed/PIW Conveyors** – to operate and last in severe conditions, wet and dry, and aggressive mining conditions.
 - Conveyor belt speeds that exceed 900 fpm and/or greater than 1500 PIW.
- **Heavy Duty Rolls** – polyurethane lagged, tapered rollers are mounted onto the pivot mechanism, which can be individually replaced as wear occurs.
- **Enhanced Sealing/Bearing System** – thrust and tapered roller bearings and enhanced sealing system for the most aggressive mining conditions.
- **Available in low profile design for restricted applications.**



Also Available Tru-Trainer®
Dual V-Return Urethane Idler

Tru-Trainer® Tapered Troughing Idlers

The Tru-Trainer® Tapered Troughing Idler is based on an enhanced load carrying design which features quicker activation, increased swing and overall better performance. There is no edge damage and the troughing angle is now adjustable.

- **Internal Center Pivot** – As the conveyor belt moves off-center the conveyor belt slides up the wing roll and thus causes the Tru-Trainer® to instantly pivot on its internal pivot and steer the conveyor belt back to center with minimum force.
- **Activating Wing Rollers** – are set to have a maximum effective contact between the belt edge and the wing roller of 25°-55° (instead of the usual 90°), and are compatible with all troughed belts from 15°-45°.
- **Operates in All Conditions** – Quick activation in both wet and dry conditions.
- **Easy Replacement** – Both the tapered wing and the center roller can be easily replaced as wear occurs.



Dura-Sleeve™ Idlers

Dura-Sleeve™ Urethane Return Disc Idlers are used on abrasive mining conditions such as iron ore, coke, copper/gold ores, underground coal mining and other hard rock mining conditions wear traditional rubber disc and steel idlers don't last. They are also used when wet or sticky materials tend to cling to the belt, where corrosion resistance is required or where chemical reaction to iron or steel is involved.

- **Patented Design** – of our idler sleeve clamping system utilizes you to replace worn out rubber or other urethane disc return idlers.
- **Abrasion Resistant Urethane** – compounds provide wear ability that exceeds 5 times the wear life of standard rubber disc return idlers.
- **Meets all CEMA Standards** – and available in any belt width and inside and outside roller diameter.
- **CEMA D, E and F** – idlers are available for immediate shipment

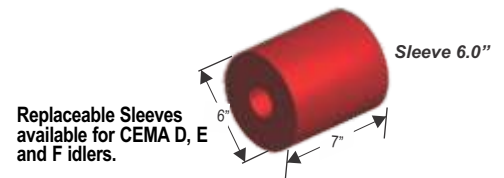
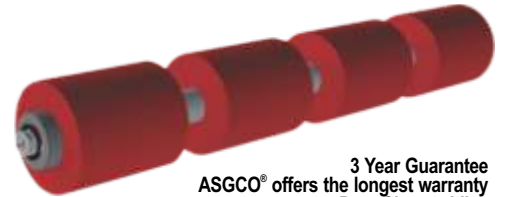

Slide-Lers™

ASGCO® Slide-Ler™ is a modular designed product that allows you to remove the wing and center roll hangers for easy replacement of your idler rolls. It can also be designed to hold any manufacturer roll in the industry. The Slide-Ler™ minimizes down time and can be accessed from both sides of the conveyor system.

ASGCO® Slide-Ler™ (One-Sided) is a patented product designed to be maintained from one side of the conveyor system. This is ideal for systems with access on one side only, where a conveyor is located against the wall or high in the air with a catwalk on one side. This allows you to replace rolls with minimal downtime and eliminate the need for man lifts or having to work in a confined space.

- **Perfect for Confined Spaces** – due to the frames only take-up 8" (200mm) of width when using 6" (150mm) rollers.
- **Improves Safety** – by allowing maintenance to easily remove the rollers without having to remove any of the idler frames.
- **Meets all CEMA Standards** – available in any belt width, troughing angle or idler.

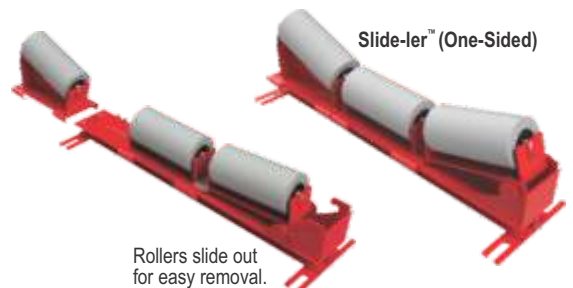
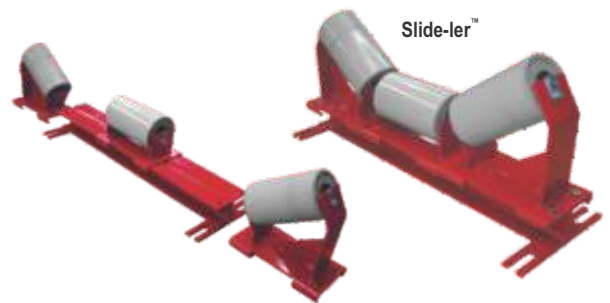

LOAD ZONE SUPPORT

Slide-N-Roll™ Beds

Slide-N-Roll™ Beds provide for an effective load support while helping to eliminate dust and spillage in the conveyor load zone. By replacing the side troughing idlers with low friction UHMW bars, this reduces the belt friction and eliminates the gaps in between the idlers to provide an effective sealing surface for the skirting.

- **Increase Belt Life** – by removing the gaps, scalloping and pinch points between the belt and the skirt liners that can cut and gouge the belt.
- **Seals the Transfer Point** – by supporting the belt edge on a flat surface that allows the skirting to work more effectively for an effective seal.
- **Robust Designed** – steel frames and 1" (25mm) thick UHMW slider bars provide excellent wear life.
- **Engineered and Designed** – beds can be made into 4' (1200mm), 5' (1500mm), 6' (1800mm) or 10' (3000mm) lengths.
- Any troughing angle.
- Number of frames will be determined by each application.

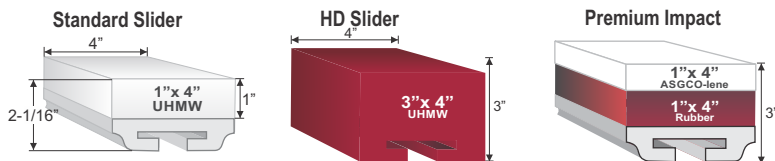

Standard Slide-N-Roll™ Slider bars are easy to remove and replace.



Impact Slide-N-Roll™

3 Roll Slide-N-Roll™ Beds

ASGCO®'s patented **3-Roll Slide-N-Roll™** is the ultimate in loading zone spillage control for wide, hi-speed and high tonnage belts as seen in below ground, above ground mining and port facilities. Our patented design encompasses a three-roller idler with low-friction UHMW bars, creating a dust free high-speed transfer point.

- **Specifically Designed** – for wide, hi-speed (over 700 fpm), and high tonnage conveyor systems.
- **Reduces Dust** – by maintaining a flat area in the load zone for the skirting to maintain an effective seal against the belt.
- **Robust Design** – for the toughest applications in the material handling industry.
- **Custom Built** – beds can be made into 4' (1200mm), 5' (1500mm), 6' (1800mm) or into our 10' (3m) standard length bed with 5 frames.



Roller Cassette™ Beds

Roller Cassette™ incorporates the advantages of slider and impact bars for sealing while maintaining constant rolling support for the conveyor belt in the load zone. This system provides additional rolling support as well as being able to eliminate the deflection between the belt and standard impact or troughing idlers.

- **Load Supported** – by having up to 4 sets of troughing idlers (12 rolls) in an area that you would normally only have 2 (6 rolls).
- **Custom Designed** – to suit your particular application.
- **Available** – Impact, Steel, or Ceramic rollers.
- **Available** – Stainless, Galvanized or Steel frames.
- **Meets All CEMA Standards** – and available in any belt width, or troughing angle.

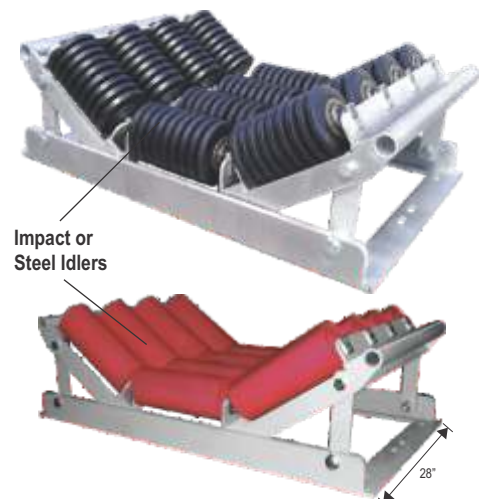

Impact or Steel Idlers

Impact Cradle Bed™

Impact Cradle Bed™s are (patent pending) designed for whatever you throw at them. Our modular style impact beds provide impact protection for the conveyor belt, as well as a tool to help control spillage in the conveyor-loading zone.

- **Improved Impact Cradle Beds™** – no pinch point or idler junction area utilizing our 17.5 degree bars.
- **Absorbs Impact** – with our impact bars that are manufactured with our absorbent, 40-durometer rubber that can really take the shock of large material.
- **Modular Designed** – beds can be manufactured in 2' (600mm), 4' (1200mm) or 5' (1500mm) long, depending upon the size of your material impact area.
- **Available in Either** – standard duty (1,000 ft/lbs) or mine duty (2,000 ft/lbs) of impact.

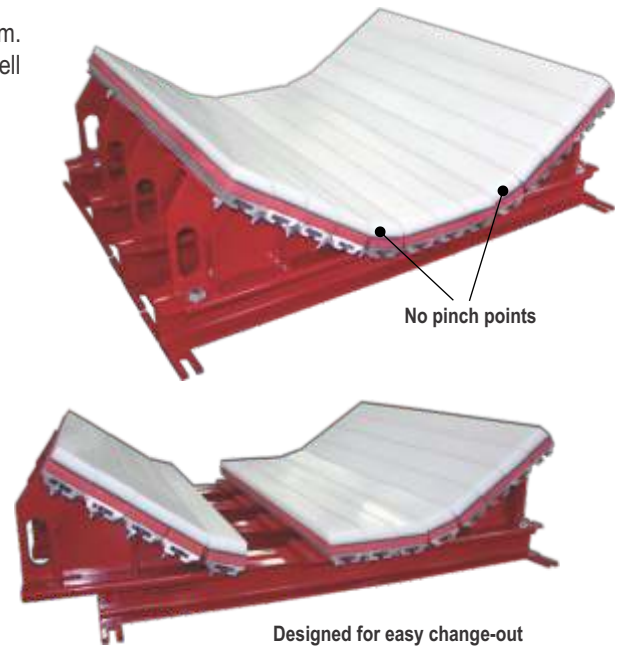
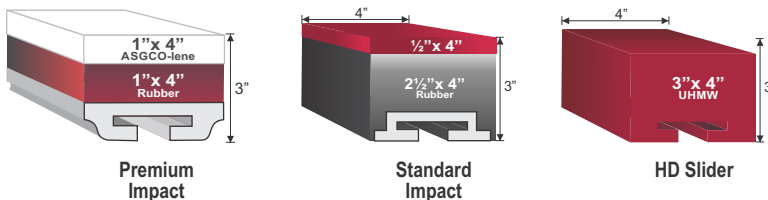

Pro-Zone™

Pro-Zone™ is a patented, modular, dust-free conveyor belt load-zone system that optimizes the sealing for air/dust tightness of the receiving conveyor belt. This "skirt-less" fully self-contained system is comprised of our Slide-N-Roll™ beds with our removable "slide-out" designed UHMW and steel side supports and easily removable center rolls. Side guards, internal splash sealing system, dust curtains and angled hoods (aluminum or steel) completely enclose the entire system.

- **Environmentally Friendly** – due to significant reduction of airborne and fugitive dust and avoiding any risk of product loss in the loading area.
- **Increased Productivity** – and longer conveyor belt life because the completely sealed load zone helps eliminate material turbulence and conveyor belt cover abrasion.
- **Lower Maintenance Costs** – by having a "skirt-less", fully contained system that needs no adjustments of metal skirtboards or rubber skirting adjustments.
- **Modular Design** – can be installed in any combination of 4' (1200mm) or 5' (1500mm) lengths to completely cover load zone area. Quickly removable dust hoods, slide-out side sections and removable center rolls aid in the installation and maintenance of the system.
- **Made in the USA** – completely engineered, designed, fabricated and stocked in the USA.

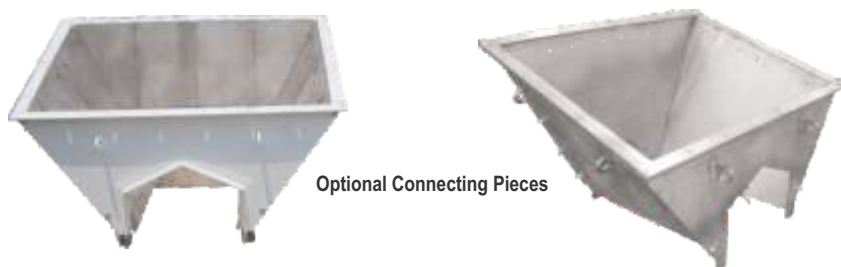
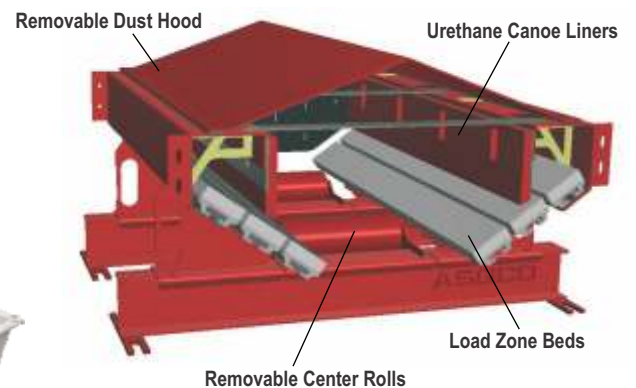

SKIRTING & DUST CONTROL

Clamp-Mount®

Our **Clamp-Mount®** skirting clamps help eliminate spillage and dust in the conveyor transfer point. The **Clamp-Mount®** installs easily and allows for one person to replace or reposition the skirt rubber.

- **Increase Conveyor Performance** – by helping to eliminate spillage and dust in the loading zone.
 - **Reduce Downtime** – by the simple clamp adjustment and release to allow repositioning or changing out skirting in minutes versus hours, without tools.
 - **Rugged Construction** – of our 9" (225mm) high by 24" (600mm) long clamp provide effective locking ability for any type of skirting material.
- Alternative Clamps* – include a stainless steel, a low-profile 6" (150mm), and an economical single clamp.

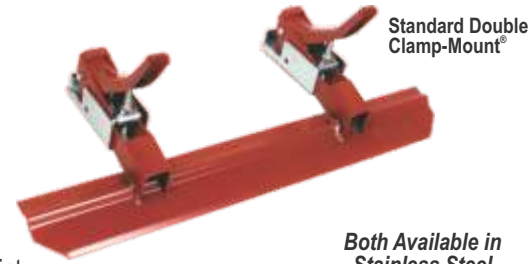

Clamp-Mount MDX™

Our **Clamp-Mount MDX™** skirting clamps helps eliminate spillage and dust in the conveyor transfer point. The **Clamp-Mount MDX™** installs easily and allows for one person to replace or reposition skirt rubber.

- **Increase Conveyor Performance** – by helping to eliminate spillage and dust in the loading zone.
 - **Reduce Downtime** – by the simple clamp adjustment and release to allow repositioning or changing out skirting in minutes versus hours, without tools.
 - **Mine Duty Construction** – 18" or 24" heavy duty clamp system with keeper, fabricated from 3/8" thick steel.
 - **Easy Adjustment** – Patented adjustment nut is cast stainless steel
 - **Versatile** – Can be used with any of ASGCO® sealing compounds.
- Alternative Clamps* - include a stainless steel, a low-profile 6" (150mm), and an economical single clamp.

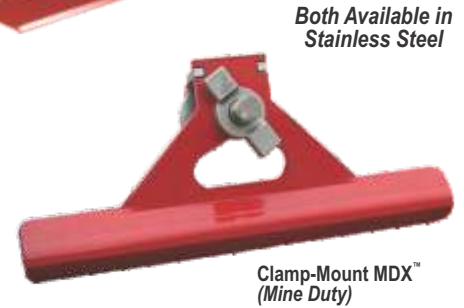

For quality sealing results, use **Clamp Mount®** on a vertical chute wall with 1" ORG compound. For superior sealing, combine **Clamp-Mount®** with ASGCO's Support Plate and either ORG (¼" or ½" thick) or 6" or 8" Tri-Seal™ or Multi-Seal™.

Tri-Seal™, Multi-Seal™, SX3™, Dura Seal™ (ORG), B&R Dura Seal™, Dura-Tuff™

Tri-Seal™ Skirting

- **Triple Sealing** – action uses 3 deterrents to stop fines and dust from escaping the load zone.
- **Works Great** – on conveyors where dust is a problem, in below ground and above ground mining, pulp and paper.

Multi-Seal™ Skirting

- **Multiple Sealing** – action is adjustable, and can be reversed for the full life of the skirting material.
- **Works Great** – where you need flexibility and dust is a problem.

SX3™ Skirting

- **Three points of contact** – action uses uniquely designed 55 durometer EPDM to stop fines and dust from escaping the load zone.
- **Works Great** – on conveyors where dust and fines are an issue, in below ground and above ground mining, pulp and paper and gypsum.

Dura-Seal™ (ORG) Skirting

- **Abrasive and Cut Resistant** – Dura-Seal™ is the toughest and most cut resistant 45-durometer-rubber material available anywhere.
- **Works Great** – in abrasive and impact area conditions where cut and gauge is a problem, as seen in hard rock mining.

B & R Dura-Seal™ (ORG 45) Skirting

- **Dura-Seal™ (ORG 45)** – compound for optimum sealing and minimum wear on the belt.
- **Dura-Seal™ (60)** – compound for best wear and impact resistance.

Dura-Tuff™

- **Abrasive and Cut Resistant** – Dura-Tuff™ is the toughest and most cut resistant 62 durometer polyurethane material available anywhere.
- **Works Great** - in abrasive and impact area conditions where cut and gouge is a problem, as seen in hard rock and iron ore mining.



External Wear Liner/Skirtboard System

External Skirtboard/External Wear Liners - Installed and accessible from the outside of the conveyor transfer point means never having to enter the internal (confined space) skirtboard to service internal liners again!

- **Safer Installation** – and maintenance - prevents confined space entry.
- **Easily Adjusted** – the external adjustable bolt-on system allows for ease of adjustment and safe removal.
- **External Wear Liners** – available in Mild Steel, AR 400 Steel or Stainless Steel available in 4ft and 6ft lengths.
- **Skirting Options** – Clamp-Mount® or Clamp-Mount MDX® skirting clamps can also be installed on the external skirtboard / wear liners to aid in dust and material control.
- **Internal Liner Options** – Added protection is available in Armorite, X-Wear™ Ceramic or X-Wear™ AR 400 (straight or angled) that can be welded to the inside of the external skirtboard / wear liner system.

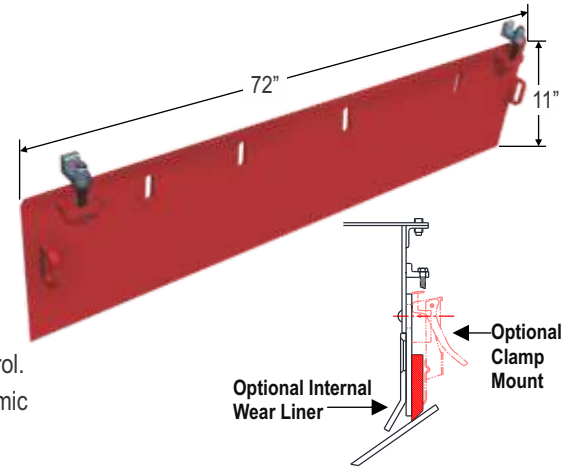

E-Z Mount®

E-Z Mount® dust sealing and containment skirting system provides an effective and economical solution to prevent dust and material from escaping the load zone. E-Z Mount® is a simple snap in place skirting system that can be installed quickly and easily into most conveyor systems.

- **Simple and Effective** – solution to help eliminate dust and material losses in the load zone.
- **Abrasion Resistant** – 60 durometer rubber compound is used to apply minimal pressure to the belts surface to create a great seal.
- **Solid Framework** – using solid galvanized steel mounting rails that get welded to the side of the chute provides the framework to snap the E-Z Mount® into place.



Dust Curtains

Dust Curtains help in the reduction of dust throughout the transfer point. These curtains outlast and outperform standard rubber curtains due to the ISO materials used by ASGCO®.

- **Allows Dust to Settle** – by slowing the air velocity down and allowing the airborne dust and particles to fall to the belt.
- **ISO 340 Anti-Static / ISO 284 Flame Retardant** – materials are used in the PVC and 2 ply fabricate constructed curtains.
- **Simple Adjustment** – and installation allows the curtains to conform to the angle of repose of the material on the belt, normally 1" above the material.

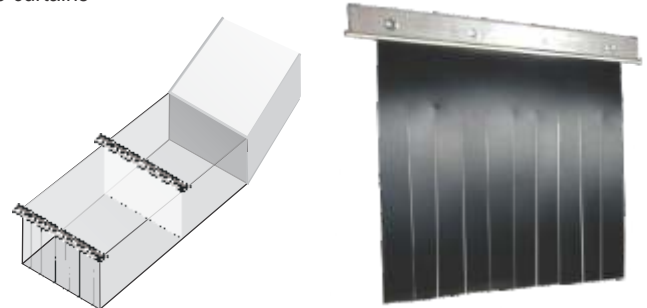

ASGCO® Curtains should be hung approx. 18" apart, forming "dead" areas where dust can settle and be collected or suppressed.

Chute Tail Box

Chute Tail Box is designed to form an effective seal at the back of the loading zone to prevent material rollback to the tail section of the conveyor.

- **Prevents Material Rollback** – by forming a sealing area for the material to collect and then travel up the conveyor.
- **Avoids Material Build-Up** – at the tail end of the conveyor.
- **Simplifies Cleanup** – by being able to return material to the belt through our inspection door mounted at the top of the box.



TRANSFER POINT DESIGN & FABRICATION

Discrete Element Methods (DEM)

ASGCO® Flo-Control™ - Conveyor Transfer Points

ASGCO® Flo-Control™ transfer point solutions solve many of the problems that are caused by the dusty, abrasive and sticky material that flows from the supply conveyor through the chutes onto the receiving belt conveyor. These materials can create extreme dusting, wear and plugging issues that often cause a complete shutdown of production or violations of the NEP fugitive dust regulations. After taking initial airborne dust readings and performing a Cloud Point Laser Scan, a 3DEM analysis is used to model the flow of the material and determine the problem areas. We then redesign the transfer chute to incorporate a "Hood" deflector as the material leaves the discharge pulley. This "Hood" deflector with adjustment control allows for fine-tuning of the material stream to direct the material for the optimum flow. The receiving end or loading zone of the conveyor utilizes a "Spoon" design to ensure uniform direction of the material without impact to the chute or the receiving conveyor belt. After installation, final airborne dust measurements are performed to insure compliance with all regulations.

The objectives and benefits of using this type of design program are:

- **Increase Production Capabilities** - by helping to eliminate spillage, chute plugging, liner wear, dust control and noise.
- **Optimize Life on Conveyor Belt and Components** - by loading the belt with minimized impact and top cover wear by using a soft or curved chute loading design.
- **Minimize Material Spillage** - in the design by center loading the material at a uniform rate and optimizing the product flow in the direction of travel after the belt is fully troughed.
- **ASGCO® Flo-Control™ Chutes** - incorporate a maintenance friendly modular design with a replaceable, long lasting, wear liner system.
- **Reduce or eliminate the Need for Dust Control and Suppression** - minimizing the dust by loading the material at a uniform rate through a curved soft loading design, maintaining effective belting support, skirting, internal wear liners and dust curtains staggered throughout.

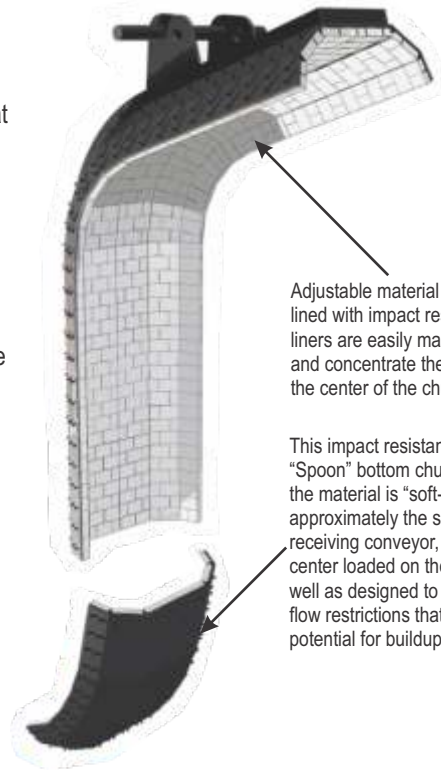

Adjustable material deflector (hood) lined with impact resistant ceramic liners are easily maintained to direct and concentrate the material flow to the center of the chute.

This impact resistant ceramic lined "Spoon" bottom chute ensures that the material is "soft-loaded" at approximately the same speed as the receiving conveyor, as well as designed to eliminate any flow restrictions that would cause the potential for buildup.

3-DEM® Transfer Point Design

ASGCO's 3-DEM® (Discrete Element Methods), is a revolutionary way to handle granular and particular material handling problems through computer simulation and 3-D CAD for complete transfer point design and fabrication. Combined with our conveyor and material handling knowledge, engineering capabilities and 3-DEM® Chute Design software, we are able to make transfer point problems a thing of the past.

- **Increase Production Capabilities** - by helping to eliminate spillage, chute plugging, belt wear, dust control and noise.
- **Optimize Life on Conveyor Belt and Components** - by minimizing impact and top cover wear by using a soft or curved chute loading design.
- **Minimize Material Spillage** - in the design by center loading the material, load the material at a uniform rate and optimize the material flow in the direction of travel after the belt is fully troughed.
- **Reduce the Need for Dust Control and Suppression** - by minimizing the dust through loading the material at a uniform rate through a curved soft loading design, maintain effective skirting, internal wear liners and dust curtains staggered throughout the loading area.

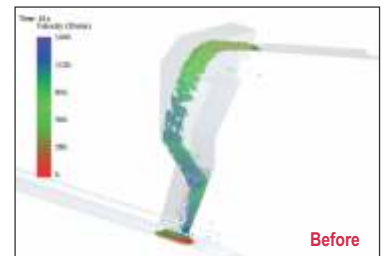

Before

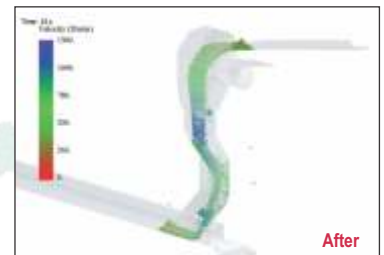

After



Armorite® 700

Armorite® 700 Brinell is an extremely hard, laminated, bi-metallic, wear resistant composite, which has a nominal hardness of 700 BHN (63Rc) produced by combining a highly alloyed chromium-molbdenum white iron (to AS 2027 15/3 Cr/Mo) and metallurgically bonding it to a mild thick steel backing plate. The resultant bond possesses high shear strength of over 250 Mpa and will not separate.

- **Excellent Wear Protection** – Maximum protection in high wear areas.
- **Impact Resistant** – The mild steel backing cushions the white iron enabling it to withstand impact.
- **Easy to Install** – Armorite® is easy to weld with minimal preparation.
- **GUARANTEED** – to last 5-6 time longer than Ar500.

Armorite® Product Benefits:

- Lower operating costs
- Longer service when compared to conventional materials
- Increased production
- Improved product efficiency
- Increased equipment availability



Skirtboard Wear Liners (Urethane, Steel, Rubber, Ceramic)

Wear Liners protect your skirtboard and extend the life and effectiveness of your sealing compound. Use the straight design where belts are fully loaded and full chute width needs to be maintained. The angled deflector plate wear liner will force larger material to the center of the belt.

ASGCO® **Ceramic Canoe Skirt Liners** are highly effective for sealing inside the skirtboard, controls the material until it becomes stable and protecting the skirt wall from wearing.

- Longer wear life – Single edge bevel or dual edge bevel for reversible wear life.
- Custom – sizes, thickness and shapes are available at customers request.

Our **Urethane Canoe Liners** are engineered to absorb impact and abrasion in all types of material transfer operations.

- Available in beveled edge or square edge.
- Slotted holes on 12" centers for ease of adjustment in the tightest applications.

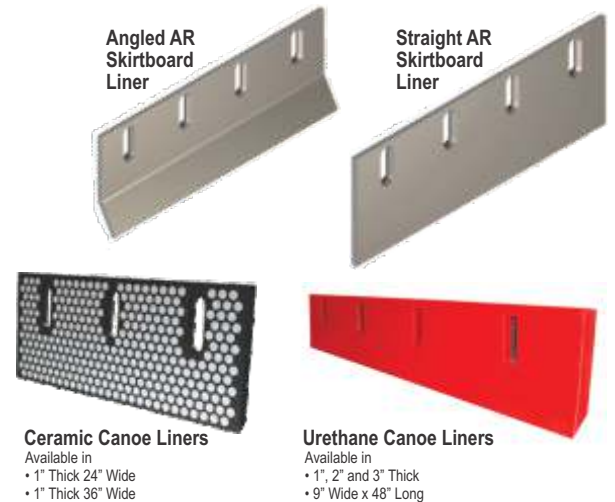

X-Wear™ Mine Duty Liner

ASGCO® **X-Wear™ Mine Duty Liner** is made of extremely hard ceramics that provide unsurpassed resistance to abrasive wear while the rubber effectively dampens the impact forces that can crack the ceramic rods. The resilient rubber matrix that surrounds the ceramic rods is hot vulcanized for superior adhesion.

- **Wide Range of Use** – X-Wear™ Mine Duty is used in the mining and quarrying industries, where severe abrasion occurs and the angles of impact are low.
- **Excellent Wear Protection** – Tough mining conditions were there is a need for both wear protection and low noise materials.
- **1/4" Steel Backing** is suitable for stud welding or plug welding.
- **Longest Wear Life Available** – Unique zig-zag pattern prevents wear channeling.
- **Easy to Install**

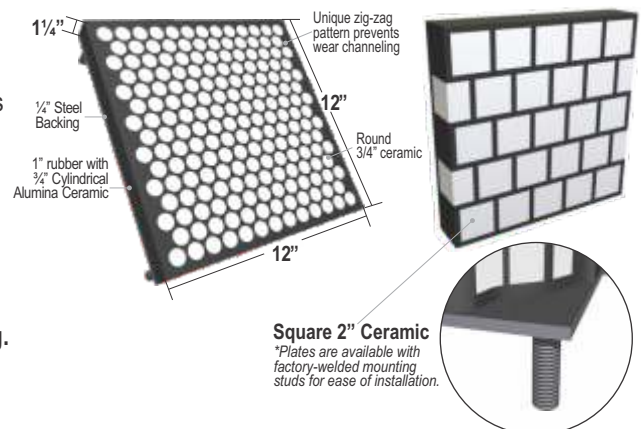

WEAR LINERS

X-Wear™ Urethane Magnetic Patch & Liner

ASGCO® X-Wear™ Urethane Magnetic Patch & Liner provides a temporary yet reliable patch system. This allows for minimal downtime in repairing a leak or worn spot, that can be found on chutes or load points, to name a few. When time allows the ASGCO® X-Wear™ Urethane Magnetic Patch or Liner can easily be removed so that a more permanent repair can be performed.

- Constructed with ASGCO-thane® Polyurethane
- No Bolting – No Welding – No Cutting to the applied area
- Eliminates the need for Hot Work permits in most areas
- Stay securely in place on vibrating screens and chutes
- Can be repositioned easily and safely, when time permits, for the repair to be done permanently
- Can be field trimmed to fit unusual surfaces or conditions, due to the polyurethane material
- Custom Size Available Upon Request

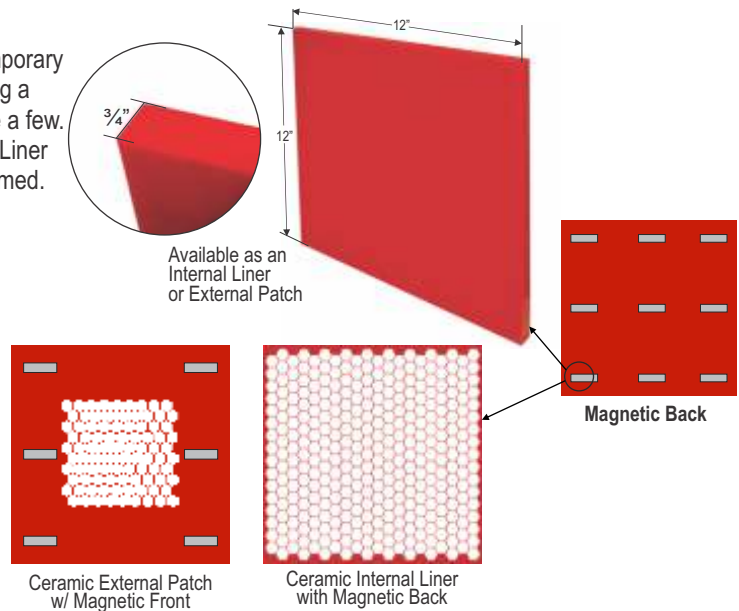

X-Wear™ (Ceramic)

ASGCO® X-Wear™ Ceramic Wear Liners are a resilient wear resistant panel made up of high density abrasion resistant ceramic bonded to a mild steel backing plate with impact resistant urethane compound. It easily out performs steel, chromium carbide overlays and conventional ceramics. ASGCO® X-Wear™ will substantially reduce your operating costs when compared to any other lining material. The ceramic is mechanically bonded to a 1/4" steel plate using impact resistant urethane epoxy.

- **Edges are Sealed** – using a urethane compound
- **Light Weight** – X-Wear™ is lightweight and easy to install by maintenance personnel.
- **Material Flow** – The smooth laminar surface of X-Wear™ provides the optimum sliding surface for material handling.
- **Custom** – The remarkable structural integrity of X-Wear™ makes it ideal for direct retrofitting of worn out chutes and hoppers without expensive repairs.
- **Noise Reduction** – X-Wear™'s energy absorbing design dramatically reduces noise.
- **1/4" Steel Backing** – is suitable for stud welding or plug welding.

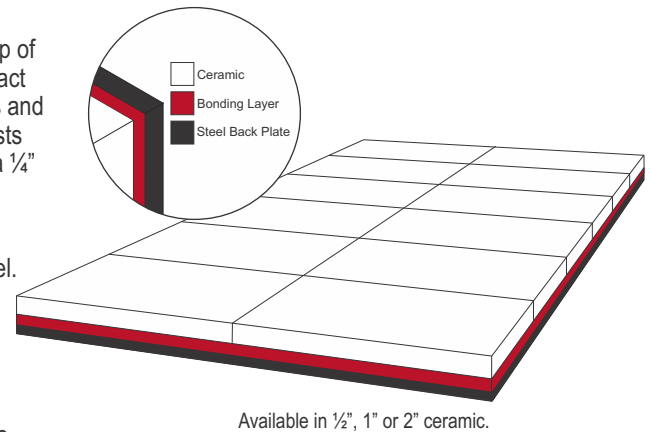

Nitronic SX™

Nitronic SX™ Stainless Steel is a nitrogen-strengthened stainless steel developed for applications requiring good level corrosion resistance and durability. The high work-hardening rate Nitronic SX™ stainless steel results in a high-strength material with superior abrasion resistance and elongation superior to Type 304L.

- **Nitronic SX™ Stainless Steel** – wear liners can be designed and fabricated in standard sizes, to allow the stocking of replacement liners. This can minimize crucial down time.
- **Nitronic SX™ Stainless Steel** – wear liners can be cut, bent and formed to meet the contours of most existing wear areas.
- **Nitronic SX™ Stainless Steel** – has the same weld ability and bending capabilities as standard 304 stainless steel.
- **Excellent Wet and Dry Abrasion Resistance**
- **Work Hardened Properties**
- **Good Resistance to Corrosion**



Arrowhead® Ceramic Pulley Lagging

Arrowhead® Ceramic Pulley Lagging provides the solution when conventional rubber lagging fails to correct belt slippage and wears prematurely. Our unique Arrowhead ceramic is designed for the highest drive factors unlike the conventional square tiles.

- **Increase Productivity** - by delivering increased traction between the belt and pulley, allows for lower belt tension than with rubber lagging.
- **Improved Belt Tracking** - due to the Arrowhead patterns self-cleaning ability, which reduces material build up and thereby eliminates the major source of misalignment.
- **Bonding Strength** - that is superior to others, due to 3mm of our neoprene compound vulcanized into bottom-side of the lagging.
- **Superior Wear** - ability in abrasive or highly wet or dry applications as seen in below ground and above ground mining.
- **Easy Installation** - can be done in place, on plant site, at your local distributor or at the pulley manufacturer. Each strip is 10" (250mm) wide x pulley face (see chart).
- **3 Year Warranty.**
- **Available** - in 5/8" and 1" thicknesses in both SBR and MSHA grade rubber compounds.

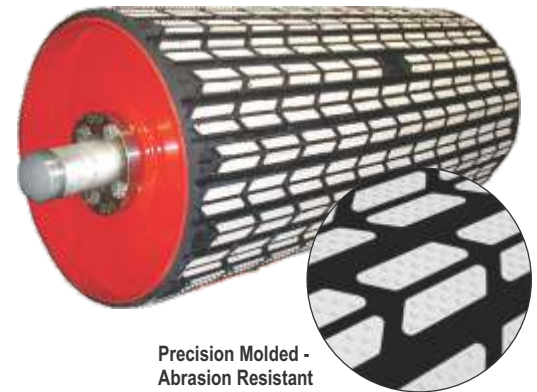

Precision Molded -
Abrasion Resistant

Semi Ceramic Pulley Lagging

ASGCO®s has added a **Semi-Ceramic™ Pulley Lagging** to their pulley lagging product line, featuring 40% coverage for smaller pulley's, non-drive pulley's and bend pulley's. ASGCO®s Semi-Ceramic™ Pulley Lagging provides the solution when conventional rubber lagging fails to correct belt spillage and wears prematurely.

- **Newly Improved Ceramic Tile** – provides robust performance in dry, wet, or muddy applications.
- **High Grade** – aluminum oxide ceramic
- **Bonding Strength** – that is superior to others, due to 3mm of our neoprene compound vulcanized into bottom-side of the lagging.
- **Pre-Chemical Backing** – for ease in installation
- **Increase Productivity** – by delivering increased traction between the conveyor belt and pulley, allowing for lower belt tension than with rubber lagging.
- **Reduce Down Time** – on non drive pulleys, where pulley change-out due to excessive wear is difficult.



Abrasion Resistant -
tiles are fully enclosed
by rubber

Arrowhead® Drive & Smooth Rubber Pulley Lagging

Arrowhead® Drive and Smooth Pulley Lagging is the solution, in an application where rubber is the answer, to help eliminate slippage, increase pulley life and to improve production. A specialty formulated combination of synthetic, natural, and neoprene rubber compounds provides our pulley lagging with excellent gripping strength and abrasion resistance.

- **Increase Productivity** - by delivering increased traction between the belt and pulley, and increasing pulley life and reducing buildup.
- **Improved Belt Tracking** - due to the Arrowhead patterns self-cleaning ability, which reduces material build up and thereby eliminates the major source of misalignment.
- **Superior Wear** - ability in abrasive or highly wet or dry applications as seen in below ground and above ground mining.
- **Bonding Strength** - that is superior to others, due to 3mm of our neoprene compound vulcanized into bottom side of the lagging.
- **Easy Installation** - can be done in place, on plant site, at your local distributor or at the pulley manufacturer. Each roll is 1/2", 3/4" or 1" thick x 10" wide by 21.3' long or 275' (85m) long rolls.



Natural & MSHA
1C-174/2 FRAS Grade Pulley Lagging

Available
in Smooth

CONVEYOR SAFETY

Safe-Guard® Return Idler Guard

Safe-Guard® Conveyor Idler Guards prevent injuries from pinch points and will catch the return idler or other material if it should fall.

- **Complies** – with MSHA Title 30 mechanical equipment guards.
- **Mounting Hardware** – made from powder coated A-36 steel.
- **Universal Mounting Brackets** – can be used with CEMA B, C, D and E (and F) idlers up to 7" in diameter with either 1½" to 6" drop brackets.
- **Durable UHMW Slotted Cage** – helps prevent material buildup and is easy to clean out. For easy access simply remove the stainless steel pins to drop open the side of the cage for maintenance.

*Fits over CEMA E & F
Return Idler Brackets*



Safe-Guard® Heavy Duty Idler Guard

- UV resistant, made from steel, will not corrode, or wear from abrasion.
- Mounting brackets and end plates made from powder coated A-36 steel.
- Cage provides complete pinch point protection and catches the roll if it breaks away from the brackets.



Safe-Guard® V-Return Idler Guard

- Heavy-duty steel construction
- UV resistant, made from UHMW, will not corrode, or wear from abrasion.
- Stainless steel pins gives easy access for maintenance.
- Mounting brackets and end plates made from powder coated A-36 steel.
- Fits over CEMA E & F return idler.

Safe-Guard® Return Idler Cage

Safe-Guard® Return Idler Cage was designed to catch the return roller applications from falling, preventing injuries to workers and to equipment.

- **Complies with MSHA Title 30.**
- **Meets OSHA Requirements 1910.219** – for mechanical power - transmission apparatus and 56.14107 for moving machine parts.
- **Easy installation** – removal and maintenance using beam clamps, links, and adjustable chains.
- **Cage protects workers and equipment** – from falling idlers.
- **Available in various sizes** – fits most belt conveyors, 4"-7" diameter idlers.

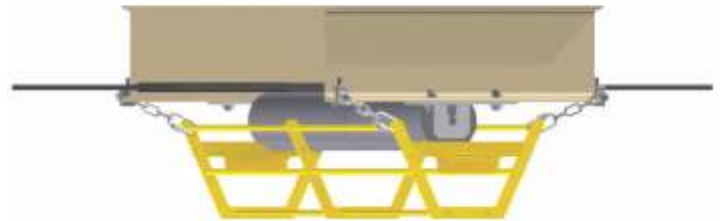

Also Available Safe-Guard®
Return Tracking Idler Cage

Safe-Guard® Modular Conveyor Flat Guard

Safe-Guard® Modular Conveyor Flat Guard is a modular, powder coated, all steel guard that is typically mounted to the conveyor to guard against moving equipment and protect your workers from injury. They are pre-engineered panels that install easily and prevent workers from unauthorized access and keep workers from getting too close to moving parts and equipment.

Quick and Modular Set-Up

- Available in various standard and custom sizes.
- Drop pin / wedge clamps holds the guard securely.
- Shipped with mounting kit for quick assembly.

Effective

- Safety yellow powder coated steel for high visibility.
- Keeps workers away from moving parts and pinch points on the conveyor.

Regulation

The installation of safety-oriented products can help create a safer plant that is easier to service and maintain. See OSHA and MSHA guidelines for safety compliance.

Compliant

Meets MSHA, OSHA, and Canadian Safety Standards.

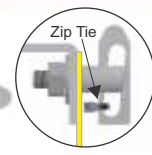
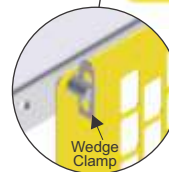
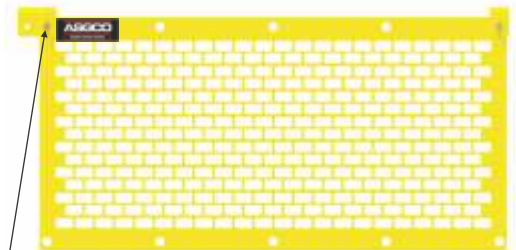

Side View
Open

Closed with optional
heavy duty zip tie

Safe-Guard® Chute Inspection Door

Safe-Guard® Chute Inspection and Access Doors are a necessary part of any material handling system. Add an inspection door to your existing head chute for access to cleaners, for chute clean-out, and blade change-outs.

- **Safety** - Inspection screen guard standards on every door for the ability to safely inspect equipment while it is running
- **Low Profile Steel Construction** - with EPDM dust seal that can withstand temperatures from -40° degrees F to 200° degrees F.
- **Quick and Easy Installation**
- **Custom Size Available**



Safe-Guard® Standard Door
12 Gauge .1046



Safe-Guard® Heavy Duty Door open with Safety Screen Guard
11 Gauge .1196

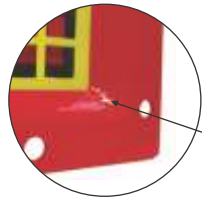

45° flange on the interior of the door sheds fines that accumulate

Safe-Guard® Chute Inspection Door Available Size

Standard Door	12"x12"	12"x18"	18"x24"	
Heavy Duty Door	12"x12"	18"x24"	24"x24"	24"x24"

Safe-Grip™ Belt Clamps

The patented **Safe-Grip™** conveyor belt clamps offers exceptional belt clamping for all types of conveyor belt maintenance and the only conveyor belt clamps that provide a POSITIVE even pressure across the entire width of the conveyor belt.

Available in Two (2) Versions:

- **BC6:** (6 Tons) for medium duty coal and coal fired power plants; copper and gold mining; iron ore and steel mills; bulk shipping terminals; aggregate and cement and mineral mining; pulp and paper mills.
 - Max Belt Thickness: 2" (50mm)
- **BC8:** (8 Tons) for heavy duty wide conveyor belts in coal and coal fired power plants; copper and gold mining; iron ore and steel mills; and bulk shipping terminals.
 - Max Belt Thickness: 2.25" (60mm)

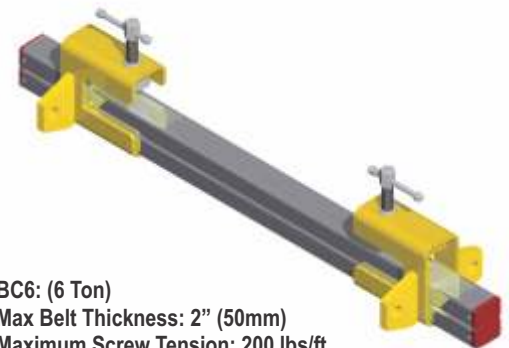

BC6: (6 Ton)
Max Belt Thickness: 2" (50mm)
Maximum Screw Tension: 200 lbs/ft

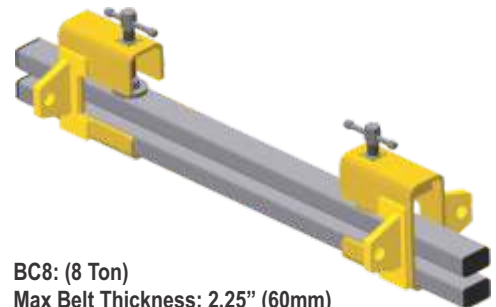

BC8: (8 Ton)
Max Belt Thickness: 2.25" (60mm)
Maximum Screw Tension: 225 lbs/ft

Safe-Guard® Return Roll Changer

The patented **Safe-Guard® Return Roll Changer** allows you to remove and replace a roller from a single side of a conveyor and from whichever side the catwalk is located.

- **Universal mounting**, Safe-Guard® Return Roll Changer can be mounted on either side of the conveyor system.
- **One Side Return Roller Access** – allows removal and replacement from a single side of the conveyor.
- **Reduces maintenance time** – for roller replacement.
- **All steel construction** – coated finish with industrial grade powder.
- **Custom Size Available**

Easy to change out from either side of the conveyor.



VULCANIZING PRESSES

Vul-Con™ Sectional Vulcanizing Press

ASGCO® are light weight, durable and versatile with VUL-CON™ Vulcanizing Presses complete availability of coverage for all splice lengths, fabric ply or steel cord. Our presses are easy to set-up and operate and easy to maintain. VUL-CON™ Vulcanizing Presses are made of high grade aluminum platens and beams to provide maximum tensile and bending strength with minimum weight. All VUL-CON™ Vulcanizing Presses provide uniform temperature and pressure required to vulcanize a wide array of conveyor belts. We manufacture to all sizes and have a stock of the more traditional sizes used in the industry.

- Lightweight compact design for easy transport
- Includes flush valves and inset bolts/nuts connecting the traverse bars
- All electrical systems are CE, CSA and UL approved
- Durable for use in harshest of environments
- Pressure bolts pass through the cross beam profile for a high level of safety
- Exact temperature regulation via an electronic control box
- Even pressure distribution across the splice area.
- Vulcanizing temperature is uniform and accurate.
- Automatic features for setting the temperature and curing time
- Standard sizes are available (custom size upon request)

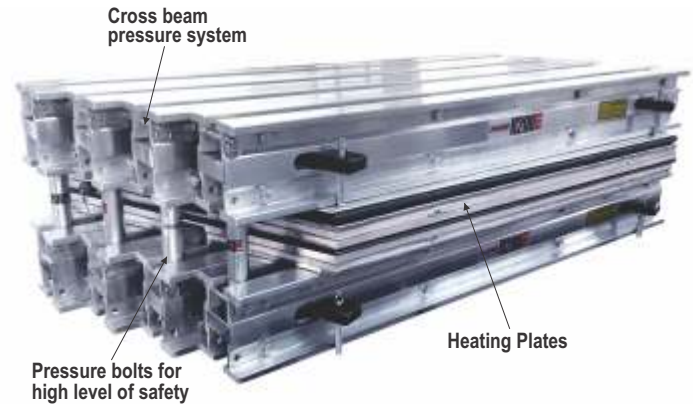

PARTNERS WITH  

Vul-Con™ EZ Series Vulcanizing Press

ASGCO® VUL-CON™ EZ Series Frame Press is a solid aluminum frame style vulcanizing press that allows for quick and easy operation. With end handles and positioning rings (for larger models), the Vul-Con™ EZ Series Vulcanizing Press is easy to maneuver into the desired splice position.

- Pressure Bag uniform pressure system across splice surface
- Custom "Extruded Plank" cooling system within platens
- Innovative "Silicone Element" fast heating system
- Upper and Lower aluminum frames
- Platens built to order in either a rhombic or rectangular design.
- Platen maximum temperature 325°F (163°C)



PARTNERS WITH  

Control Box

Electronic Control Box with Electronic Temperature Control

The new VUL-CON™ Switchgear Box is the most advanced control system in the world. Incorporating controls for 2 platens. Splice data can be stored and recalled through the built-in data logger.

- CE, CSA and UL Approved All electrical CE, CSA and UL approved
- Exact temperature reading in each heating plate via thermo-sensor PT 100
- Electrical, as per CE, CSA and UL standards
- Quick and simple programming of the electronic temperature control
- Differential monitoring, individual heating circuits
- Each control box can operate one set of platens
- VUL-CON™ Switchgear Box can be used on the Sectional Vulcanizing Press and EZ Series Vulcanizing Press



ASGCO® Conveyor Training (ACT™) Conveyor Product & Installation Training

ASGCO® Conveyor Training (ACT™) offers classes created to provide your team with the highest quality training to solve your conveyor problems. Each day your team will spend classroom time discussing the most common conveyor problems such as mis-tracking, spillage and dust control. The remainder of the day is spent in our hands-on conveyor training room, installing components on a full size working conveyor. Our experienced staff will show your team the ease of installing and maintaining ASGCO® conveyor components. We can also develop the training course to meet your particular conveyor needs. And if you have a specific conveyor problem, we will teach you to discover the real issue, find out what others have done, brainstorm multiple solutions and implement the best one.



Customized Training Classes Can Be Arranged

The goal of our training program for everyone that attends, is to learn one new / better technique / quicker / and safer way to solve everyday conveyor problems to help make their conveyor systems run more efficiently.

Training Seminars Include:

Conveyor Fundamentals & Safety

- Introduction and identifying components of a conveyor.
- Advanced fundamentals to a conveyor system
- Conveyor Safety

Increasing Conveyor Efficiency

- What is fugitive material and it's causes, effects and costs.
- Problems created by carry-back, spillage and dust
- Conveyor belt tracking causes and cures
- Conveyor Laser Alignment
- Transfer point/load zone design
- How to prevent material spillage from the load zone
- Measuring and slowing down air velocity
- Material wear liners - *What, where and why*

ASGCO® Conveyor Training (ACT™) Conveyor Training 101 Program

Conveyors are the lifeline to any aggregate plant's productivity. This Training class will provide the "Conveyor 101" program that has proven successful at facilities across the country.

Attendees will gain an understanding of:

- Conveyor systems, conveyor belts, their components and how they affect your plant's performance.
- Safety guidelines for working on or around conveyors.
- Tips on reducing fugitive material and dust (and solutions to control it)
- Ideas on how to implement a conveyor inspection and maintenance service program that works for your plant.

.....and much more! Our training program can be customized to fit your needs.



SERVICE & SUPPORT

At ASGCO® Complete Conveyor Solutions, we use engineered products and services to provide our customers with the best solutions to their conveyor material handling applications. We are focused on developing cost effective and technologically advanced products, specifically designed for optimum conveyor performance.

Combined with our national network of distributors, we can provide you with custom engineering and design to meet your specific conveyor needs, along with installation and maintenance programs that will streamline your operation by increasing production up time and lowering costs. Together we are part of a coordinated implementation team focused on insuring your success.

- Custom design & engineering
- International network of distributors
- Installation & Service
- Conveyor Product & Installation Training
- Custom Conveyor Maintenance Programs

The reliability and efficiency of your conveyor system ultimately depends upon the products and maintenance you choose

LASER ALIGNMENT

ASGCO®'s Laser Alignment Services improves the overall conveyor performance using state-of-the art laser equipment and digital processors. ASGCO® technicians can accurately analyze the alignment of all the components and structure of the conveyor for better conveyor efficiency.

- Increased Production Capabilities
- Optimize Life on Conveyor Belt and Components
- Minimize Material Spillage, Dust and Noise
- Reduce the Need for Dust Control and Suppression
- Provides Accurate Analysis of all conveyor pulleys, drives, take-ups, components and structure.
- Precise Corrections are identified on a detailed conveyor status report.



Total Satisfaction Guaranteed

POINT CLOUD 3D LASER SCANNING

The laser scanner **Focus3D X 130 HDR** is a powerful high-speed 3D scanner, delivering realistic and true-to-detail scan results. The ultra-portable Focus3D X 130 HDR enables fast, straightforward, and yet accurate measurements of façades, complex structures, production and supply facilities, accident sites, and large-volume components.

- Distance accuracy up to $\pm 2\text{mm}$
- Range from 0.6m up to 130m
- Noise reduction 50%
- Safe and fast as-built data capturing with superior color detail
- Reliable life-like visualization, even under extreme lighting conditions
- Reduced complexity by integrated scanning and imaging workflow for all kinds of measurements even in challenging environments
- Allows models to be overlaid onto cloud point scan to double check accuracy

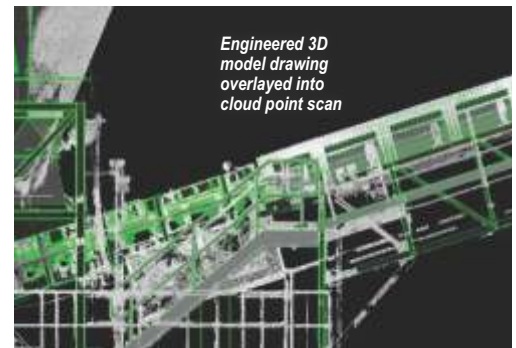

ASGCO® SERVICES

Installation & Field Services

Your equipment will be routinely serviced and checked to insure maximum performance. A program of planned and scheduled maintenance can avert many breakdowns. Our program's goal is to service the equipment properly at the lowest cost.

- Scheduled conveyor walk through
- Identification of problem areas
- Installation of products
- Complete maintenance schedule
- Maximum product performance
- Increased productivity from less down time
- Less operating cost



Maintenance Services

Our ASGCO® Master Distributor's experienced field and installation service technicians are ASGCO® certified and trained. Prompt, reliable emergency service is available 24/7/365 days a year. On-site and on-time fabrication and completion are essential in any installation to shorten the schedule and minimize costly downtime.

- Component Installation
- On-Site Fabrication
- Dust Control Products & Services
- Pulley Lagging
- Laser Alignment
- Custom Conveyor Maintenance
- Field Services Program
- Chute Liners installation/retrofitting.



INDUSTRY APPLICATIONS

Coal & Power



3-DEM® Designed Transfer Chute



Tru-Trainer® Dual Urethane Return Idler



Impact Cradle Bed™



Wash Box™ System



Super Skalper®

Minerals & Pulp/Paper



Tru-Trainer® Dual Return Idler



Clamp-Mount® with Tri-Seal™



Tru-Trainer® Flat Return Idler



Chevron™ Cleaner



Razor-Back® with Spray Bar

Metals & Steel



Skalper MDX®



Flo-Control® Hood



Tru-Trainer® Dual V-Return Idler



Arrowhead® Lagging



Safe-Guard® Flat Guard

Cement & Aggregate



Safe-Guard® Return Idler Cage



Super-Skalper®



Vul-Con™ Sectional Press



X-Wear™ Urethane Magnetic Liner



Tru-Trainer® Tapered Troughing Idler

